

HC800 Parts List

Table of Contents

Cabinet

Air Cooled

Water Cooled

Evaporator

Freezing Chamber

Dual Spray

Sump

Control Box

Wiring Diagrams

HC800 PARTS ILLUSTRATIONS AND PARTS LISTS

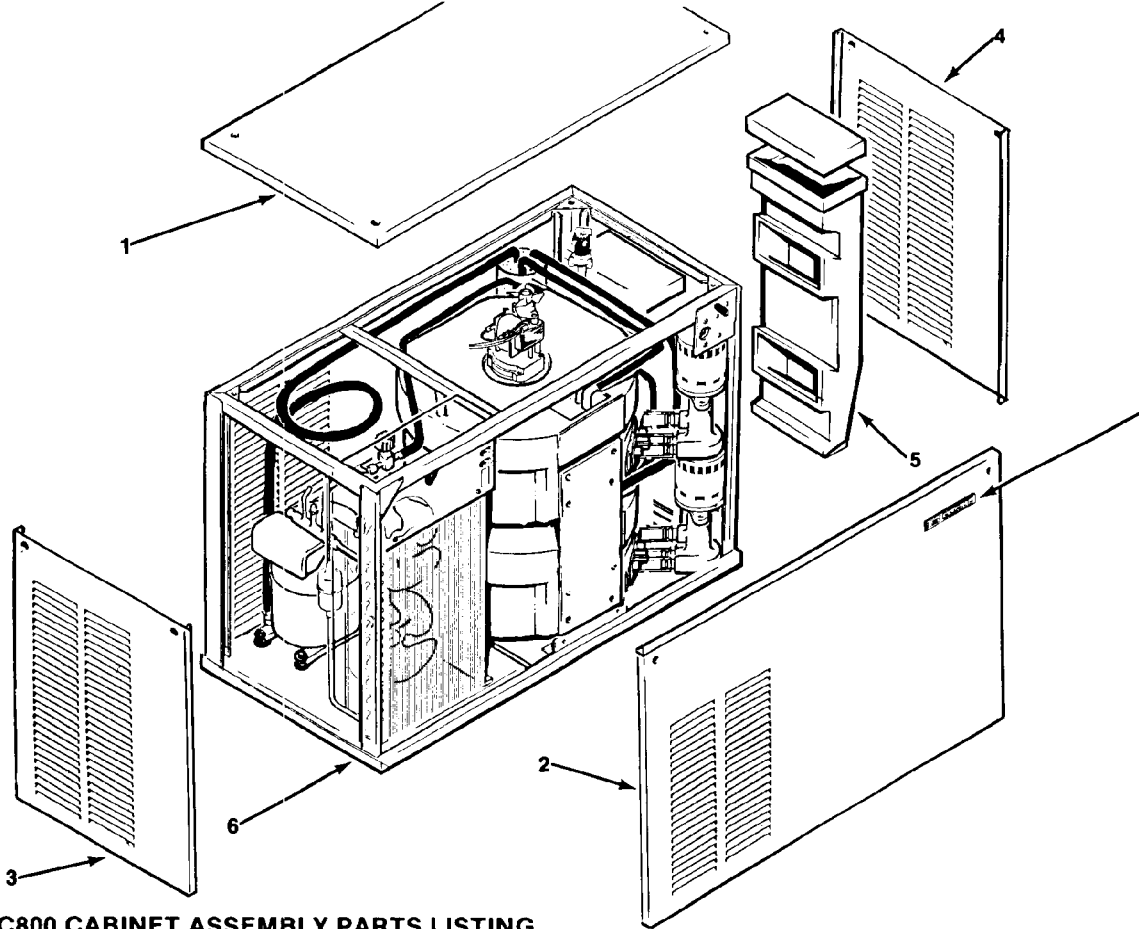

HC800 CABINET ASSEMBLY PARTS LISTING

ITEM NUMBER	PART NUMBER	DESCRIPTION	REQ'D NUMBER
1	A23784-007	Panel, Top - (Enamel) Sandalwood	1
	A23784-002	Panel, Top - (Stainless Steel)	1
		Attaching Part, Index 1	
	03-1417-15	Lockwasher, No. 8 Countersunk External Tooth	2
	03-1419-09	Screw, No. 8 x 1-1/2 S/T Flat Hd	4
2	A26183-005	Panel, Front - (Enamel) Sandalwood	1
	A26183-002	Panel, Front - (Stainless Steel)	1
		Attaching Part, Index 2	
	03-1417-15	Lockwasher, No. 8 Countersunk External Tooth	2
	03-1419-09	Screw, No. 8 x 1-1/4 S/T Flat Hd (SS)	2
3	A23899-006	Panel, Left Side - (Enamel) Sandalwood	1
	A23899-002	Panel, Left Side - (Stainless Steel)	1
		Attaching Part, Index 3	
	03-1404-10	Screw, No. 8 x 1/2 T/F Tap (Stainless Steel)	2
4	A23900-006	Panel, Right Side - (Enamel) Sandalwood	1
	A23900-002	Panel, Right Side - (Stainless Steel)	2
		Attaching Part, Index 4	
	03-1404-10	Screw, No. 8 x 1/2 T/F Tap (Stainless Steel)	2
5	A27822-001	Chute, Cube - w/Cover	1
6	A26179-001	Frame Assembly	1
7	15-0156-00	Emblem Plate	1

HC800

PARTS ILLUSTRATIONS AND PARTS LISTS

HC800 MAJOR ASSEMBLIES AIR-COOLED PARTS LISTING

ITEM NUMBER	PART NUMBER	DESCRIPTION	REQ'D NUMBER
1	12-2263-21	Pump Assembly, Water	1
	<i>No Number</i>	Attaching Parts, Index 1	
	02-0706-00	Holder, Drain Tube	1
	02-0706-00	Clamp, Worm Drive	1
	03-1407-05	Washer, No. 1/4 Plain	1
	03-0571-01	Screw, No. 1/4-20 x 1/2 T/C Hex Hd	1
2	18-3709-01	Condenser - Air-Cooled	1
		Attaching Parts, Index 2	
	03-1407-05	Washer, No. 1/4 Plain	2
	03-0571-00	Screw, No. 1/4-20 x 1/4 T/C Hex Hd	2
3	18-0231-00	Blade, Fan w/Mtg. Hdwre	1
4	02-2378-01	Mount, Fan Motor	2
5	12-1575-01	Motor, Fan - 115/208-220-60/3	1
	12-1575-01	Motor, Fan - 115/208-230/60/1	1
		Attaching Parts, Index 3	
	03-1417-03	Lockwasher, No. 8 External Tooth	4
	<i>No Number</i>	Screw, No. 8-32 x 1-1/4 Phil Recess Pan Hd	4
6	18-5100-03	Compressor - 115/208-220/60/3	1
	18-5100-02	Compressor - 115/208-230/60/1	1
		Attaching Parts, Index 4	
	18-5100-51	Grommet	4
	18-5100-50	Sleeve, Mounting	4
	03-1407-07	Washer, No. 5/16 Plain	4
	03-1405-20	Screw, No. 5/16-18 x 1-1/2 Hex Cap Screw	1
		Attaching Part, Index 6 to 7	
	03-1404-04	Screw, No. 6 x 1/4 T/F Tap (Stainless Steel)	2
7	02-2426-02	Drier	1
8	<i>No Number</i>	Control Box Cover	1
9	<i>No Number</i>	Control Box Assembly	1
		(See Page 31)	
		Attaching Part, Index 7	
	03-1417-15	Lockwasher, No. 8 Countersunk External Tooth	2
	03-1419-09	Screw, No. 8 x 1-1/4 S/T Flat Hd	
		(Stainless Steel) (used to attach LEFT end)	2
	03-1404-08	Screw, No. 8 x 3/8 T/F Tap (used to attach RIGHT end)	2
10	12-2135-01	Valve, Solenoid - Hot Gas	1
11	12-1434-01	Inlet Assembly, Water	1
12	11-0345-02	Control, Cube Size	1
13	11-0353-03	Control, Bin Level	1
		Attaching Parts, Index 10 & 11	
	03-1403-14	Screw, No. 8-32 x 3/16 Phil Recess Pan Hd	4
14	A29835-020	Exchanger Assembly, Heat	1
15	02-2038-01	Curtain Assembly	2
		Attaching Part, Index 13	
	03-1526-01	Clip, U-Type	6
16	<i>No Number</i>	Freezer Assembly, Dual (See Page 25)	1
		Attaching Parts, Index 14	
	02-0571-00	Screw, No. 1/4-20 x 1/2 T/C Hex Hd	4
17	A26230-001	Flow Control, .30 gpm Air-Cooled	2
18	16-0723-01	Water Inlet Fitting	1
19	A26161-001	Condenser Shroud	1
20	13-1394-01	Pal Nut	1

HC800 PARTS ILLUSTRATIONS AND PARTS LISTS

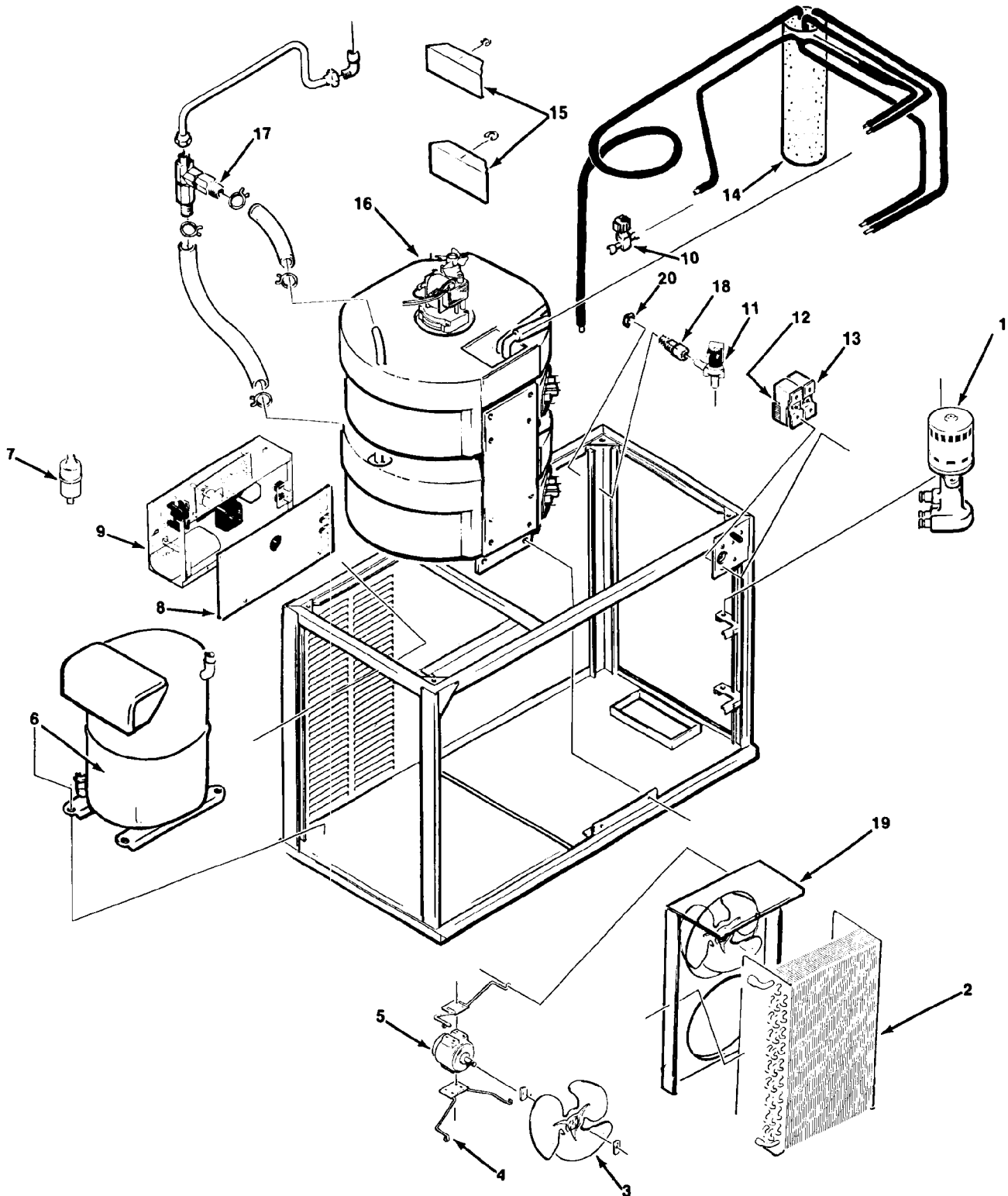

HC800

PARTS ILLUSTRATIONS AND PARTS LISTS

HC800 MAJOR ASSEMBLIES WATER-COOLED PARTS LISTING

ITEM NUMBER	PART NUMBER	DESCRIPTION	REQ'D NUMBER
1	12-2263-21	Pump Assembly, Water	1
		Attaching Parts, Index 1	
	<i>No Number</i>	Holder, Drain Tube	2
	02-0706-00	Clamp, Worm Drive	2
	03-1407-05	Washer, No. 1/4 Plain	2
	03-1571-01	Screw, No. 1/4-20 x 1/2 T/C Hex Hd	2
2	18-3306-02	Condenser, Water-Cooled	1
		Attaching Parts, Index 2	
	03-1407-05	Washer, No. 1/4 Plain	2
	03-0571-00	Screw, No. 1/4-20 x 1/4 T/C Hex Hd	2
3	16-0401-00	Elbow, 3/8 NPT x 3/8 Flare Brass	1
4	11-0198-02	Valve, Water Regulator	1
5	A15924-000	Bracket, Mounting - w/nipple	1
6	18-5100-03	Compressor - 115/208-220/60/3	1
	18-5100-02	Compressor - 115/208-230/60/1	1
		Attaching Parts, Index 4	
	18-5100-51	Grommet	4
	18-5200-50	Sleeve, Mounting	4
	03-1407-07	Washer, No. 5/16 Plain	4
	03-1405-20	Screw, No. 5/16-18 x 1-1/2 Hex Cap	4
7	02-2426-02	Drier	1
		Attaching Part, Index 5	
	<i>No Number</i>	Tie, Cable	1
8	<i>No Number</i>	Cover, Control Box	1
		Attaching Part, Index 6 to 7	
	03-1404-04	Screw, No. 6 x 1/4 T/F Tap (Stainless Steel)	2
9	<i>No Number</i>	Control Box Assembly (See Page 31)	1
		Attaching Part, Index 7	
	03-1417-15	Lockwasher, No. 8 Countersunk External Tooth	2
	03-1419-09	Screw, No. 8 x 1-1/4 S/T Flat Hd (Stainless Steel) (Used to attach LEFT end)	2
	03-1404-08	Screw, No. 8 x 3/8 T/F Tap (Used to attach RIGHT end)	2
10	12-2135-01	Valve, Solenoid - Hot Gas	1
11	12-1434-01	Inlet Assembly, Water	1
12	11-0345-02	Control, Cube Size	1
13	11-0353-03	Control, Bin Level	1
		Attaching Parts, Index 10 & 11	
	03-1403-14	Screw, No. 8-32 x 3/16 Phil Recess Pan Hd	4
14	A29835-020	Exchanger Assembly, Heat	1
15	02-2038-01	Curtain Assembly	2
		Attaching Part, Index 13	
	03-1526-01	Clip, U-Type	6
16	<i>No Number</i>	Freezer Assembly - Dual (See Page 25)	1
		Attaching Parts, Index 14	
	02-0571-00	Screw, No. 1/4-20 x 1/2 T/C Hex Hd	4
17	A26230-002	Flow Control, .50 gpm	2
18	16-0723-01	Water Inlet Fitting	1
19	13-1394-01	Pal Nut	1

HC800 PARTS ILLUSTRATIONS AND PARTS LISTS

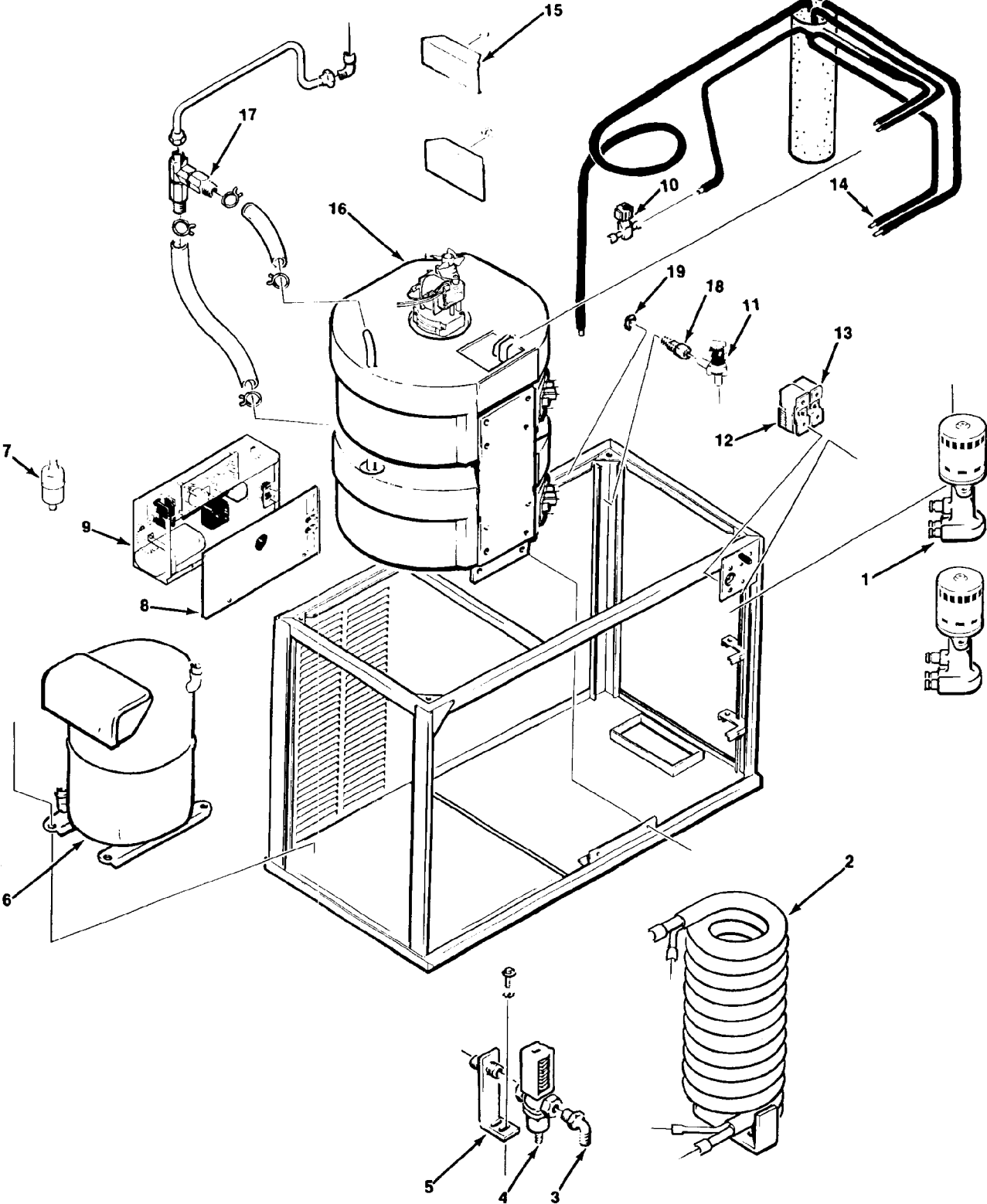

HC800 PARTS ILLUSTRATIONS AND PARTS LISTS

HC800 FREEZER ASSEMBLY - DUAL

ITEM NUMBER	PART NUMBER	DESCRIPTION	REQ'D NUMBER
1	02-2369-02	Fork, Drive - Upper (left-hand thread)	1
2	12-0675-25	Blade, Fan - Drivemotor	1
3	A24656-001	Drivemotor Assembly, Agitator	1
4	13-0176-00	Gasket - Agitator Drivemotor Assembly	1
		Attaching Parts, Index 3 & 4	
	03-1404-28	Screw, No. 6 x 1 T/F Tap	4
5	02-2369-01	Fork, Drive - Lower (left-hand thread)	1
6	A24502-001	Plate, Mount Upper	1
7	A24500-001	Plate, Mount Lower	1
		Attaching Parts, Index 6 & 7	
	03-1417-05	Lockwasher, No. 10 External Tooth	2
	03-1404-18	Screw, No. 10 x 5/8 T/F Tap (used in two upper holes in Index 6)	2
	03-1417-05	Lockwasher, No. 10 External Tooth	2
	03-1360-00	Screw, No. 10-16 x 1/2 S/T (used in middle holes in Index 6)	2
	03-0571-00	Screw, No. 1/4-20 x 1/2 T/C Hex Hd (used to attach Index 6 to 7)	3
	03-1417-05	Lockwasher, No. 10 External Tooth	2
	03-1404-18	Screw, No. 10 x 5/8 T/F Tap (used in middle two holes in Index 7)	2
	03-1417-05	Lockwasher, No. 10 External Tooth	2
	03-1360-00	Screw, No. 10-16 x 1/2 S/T (used in lower two holes in Index 7)	2
8	<i>No Number</i>	Chamber, Freezing - Upper	1
9	<i>No Number</i>	Chamber, Freezing - Lower (See Page 30)	1

HC800

PARTS ILLUSTRATIONS AND PARTS LISTS

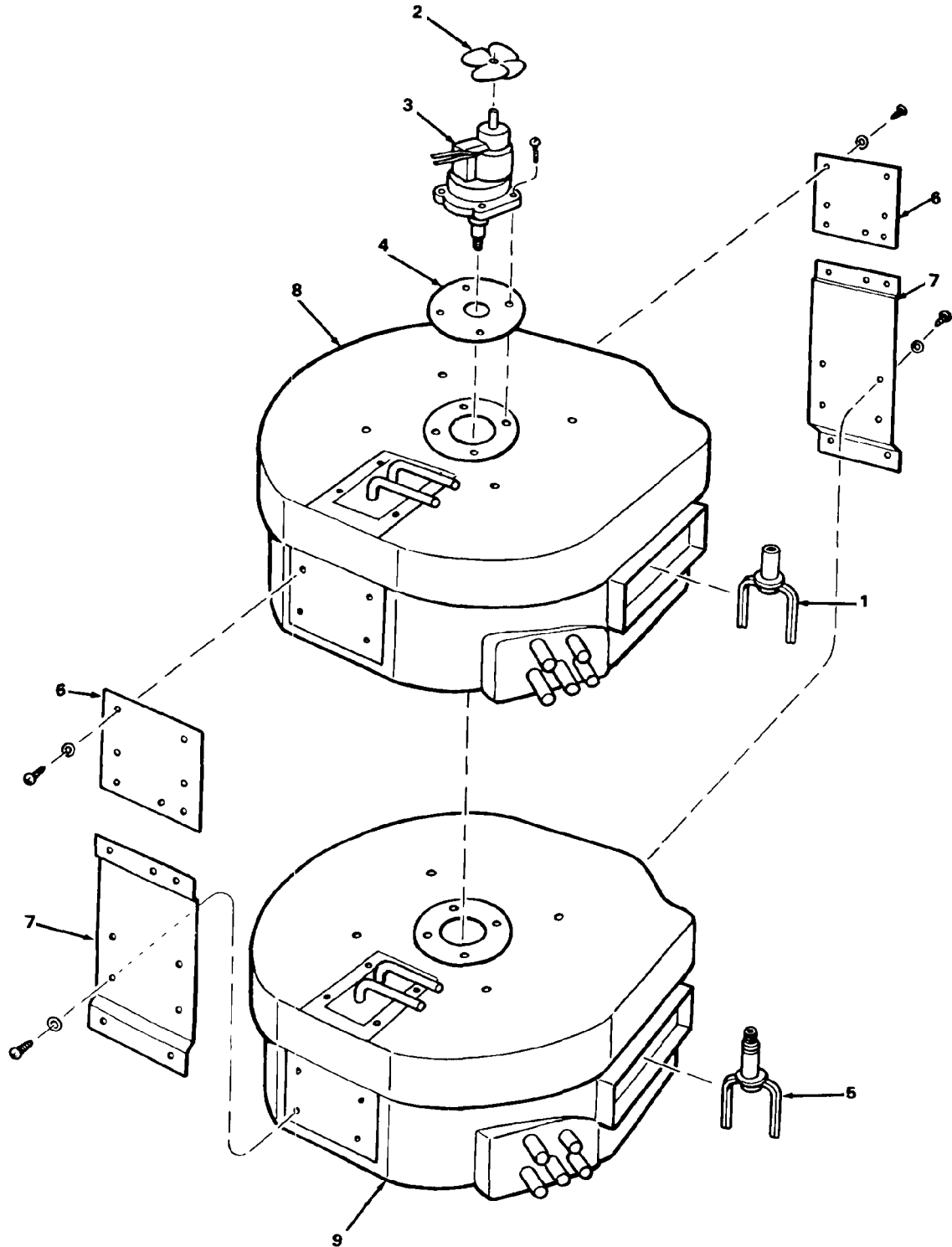

HC800 PARTS ILLUSTRATIONS AND PARTS LISTS

HC800 FREEZING CHAMBER ASSEMBLY

ITEM NUMBER	PART NUMBER	DESCRIPTION	REQ'D NUMBER
1	02-2129-01	Spacer, Tube Attaching Part, Index 1	2
	02-2065-02	Plug, Hole	8
2	02-2124-01	Cover, Insulation	2
3	02-2123-01	Cover, Freezing Chamber	2
4	A27218-002	Platen Assembly, Cup (SMALL ice cube cups)	4
	A27217-002	Platen Assembly, Cup (MEDIUM ice cube cups) Attaching Parts, Index 2, 3, 4	4
	A24830-001	Washer, Centering	8
	03-1404-10	Screw, No. 8 x 1/2 T/F Tap	8
5	A25480-001	Bar Assembly, Spray	4
6	13-0617-25	O-Ring	4
7	<i>No Number</i>	Bushing/Bearing (Left-hand threads)	2
7a	A27687-001	Bushing, Nut (Used in UPPER Chamber)	2
7b	02-2120-01	Bearing, Spray Bar (Used in LOWER Chamber) (Also order P/N 13-0168-00 Water Seal with Index 7a or 7b)	2
8	02-2028-01	Bottom, Inner	2
9	13-0674-07	Tube, Tygon (8-inch lg.) (Order by the foot) Attaching Part, Index 9	2
	02-1358-01	Clamp, Hose	4
10	<i>No Number</i>	Sump, Freezing Chamber (See Pg. 30)	2
		NOTE: Spray Deflectors below, are ONLY used on SMALL ice cube Cup Platen Assembly P/N A27218-002.	
X1	A24198-001	Deflector, Spray (Installed at rounded ends, over top of cup molds)	4
X2	A24198-003	Deflector, Spray (Installed around hole in Platen, with notch as shown)	2
X3	A24198-004	Deflector, Spray (Installed LAST, under two tubes and over ends of X2)	2

HC800 PARTS ILLUSTRATIONS AND PARTS LISTS

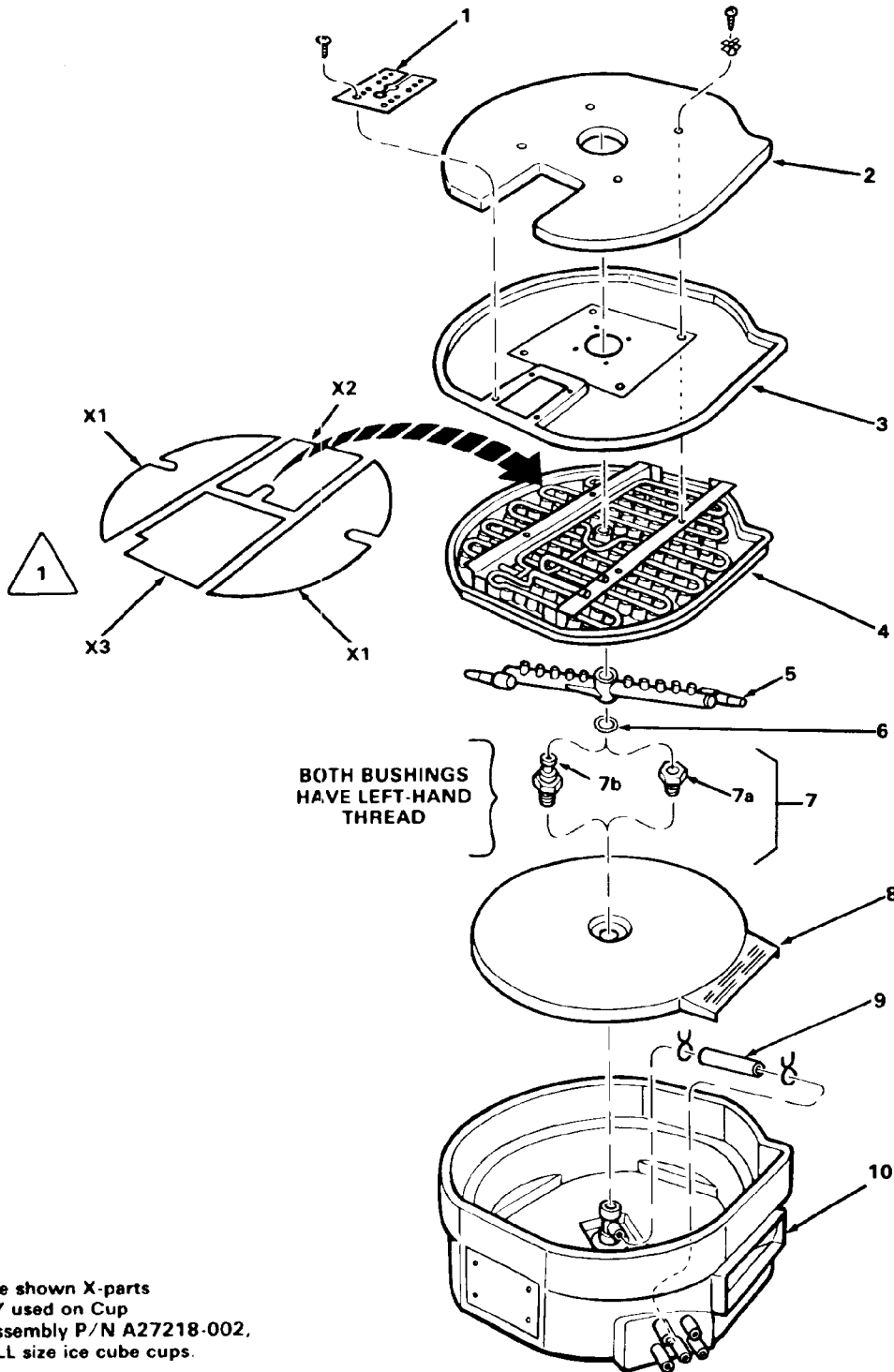

The above shown X-parts
are **ONLY** used on Cup
Platen Assembly P/N A27218-002,
for **SMALL** size ice cube cups.

HC800 PARTS ILLUSTRATIONS AND PARTS LISTS

HC800 DUAL DRIVE SPRAY ASSEMBLIES

ITEM NUMBER	PART NUMBER	DESCRIPTION	REQ'D NUMBER
1	02-2369-02	Fork, Drive - Upper (Left-hand thread)	Ref.
2	12-0675-25	Blade, Fan - Drivemotor	Ref.
3	A24656-001	Drivemotor Assembly, Agitator	Ref.
4	13-0176-00	Gasket - Agitator Drivemotor Assembly	Ref.
		Attaching Parts, Index 3 & 4	
	03-1404-28	Screw, No. 6 x 1 T/F Tap	Ref.
5	02-2369-01	Fork, Drive - Lower (Left-hand thread)	Ref.
6	A25480-001	Bar Assembly, Spray (w/rubber tips)	2
7	13-0653-00	Rubber - Spray Bar	4
8	13-0617-25	O-Ring	2
9	<i>No Number</i>	Tube Assembly, Water	1
9a	02-2271-01	Support, Spray Bar	1
9b	<i>No Number</i>	Tube, Water (Available only in Index X, Water Tube Assembly, Kit P/N A29868-001. Obsolete, order Index X.	1
10	13-0168-00	Seal, Water	2
11	A29687-001	Bushing, Nut (Also order Index 10, Water Seal)	1
12	02-2120-01	Bearing, Spray Bar	1
13	13-0675-07	Tube, Tygon (8-inch lg.) (Order by the foot)	2
		Attaching Parts, Index 13	
	02-1358-01	Clamp, Hose	4
14	02-2121-02	Housing, Inlet	2
15	A23827-001	Plate, Support - Spray Bar	2
16	03-1409-11	Washer, Non-Metallic - (7/8-inch I.D.)	2
17	02-2122-01	Plug, Bottom (Used on Lower Freezing Chamber)	1
18	A29687-002	Bushing, Nut (Also order Index 10, Water Seal) (Used in Upper Freezing Chamber)	1
X	A29868-001	Kit - Water Tube Assembly	1
X1	02-2369-01	Fork, Drive (Left-hand thread)	1
X2	13-0168-00	Seal, Water	2
X3	A29687-001	Bushing, Nut (Left-hand thread)	1
X4	A29687-002	Bushing, Nut (Left-hand thread)	1
X5	<i>No Number</i>	Tube, Water (Order Kit P/N A29868-001)	1
X6	02-2271-01	Support, Spray Bar	1

HC800 PARTS ILLUSTRATIONS AND PARTS LISTS

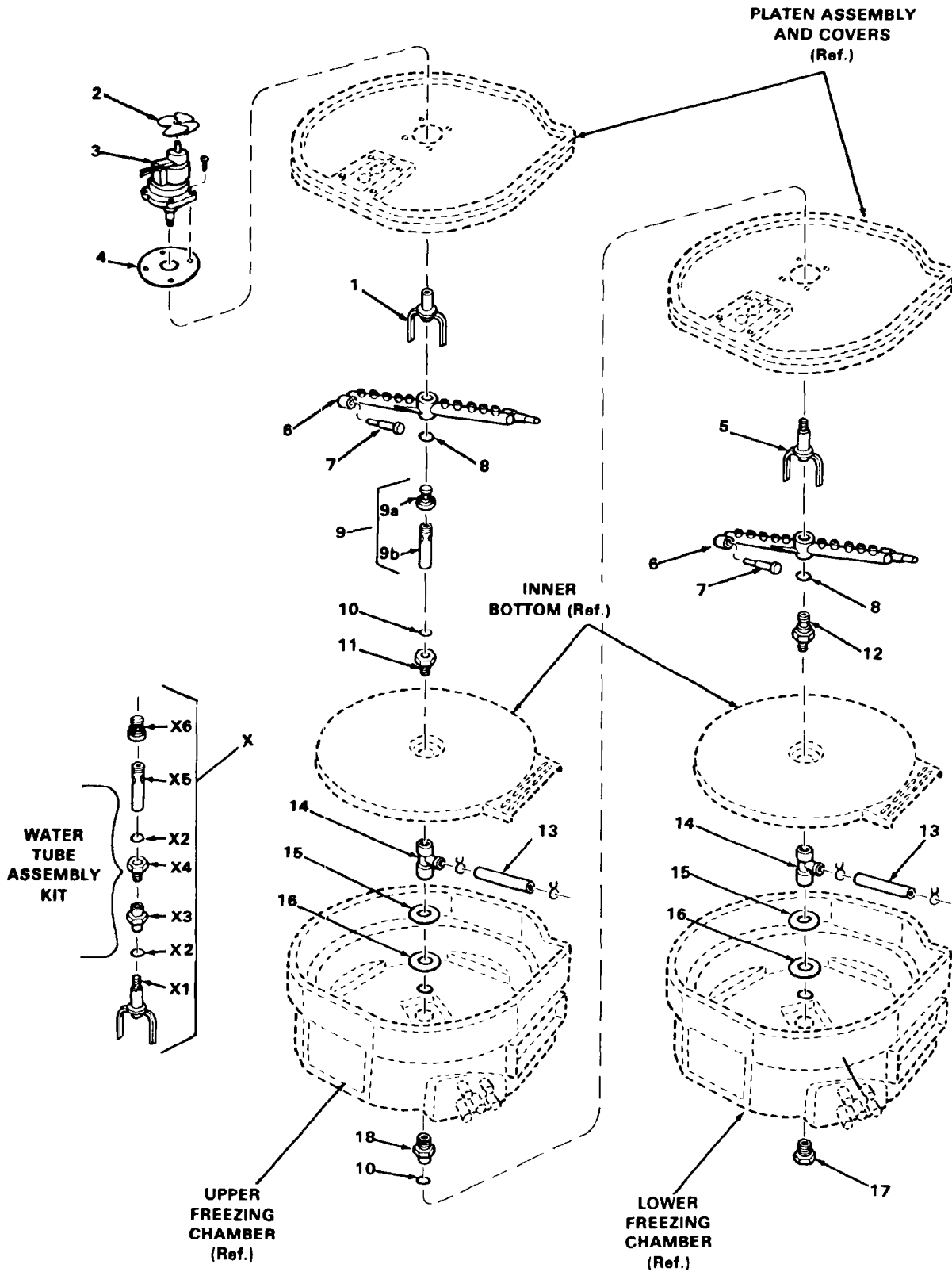

HC800 PARTS ILLUSTRATIONS AND PARTS LISTS

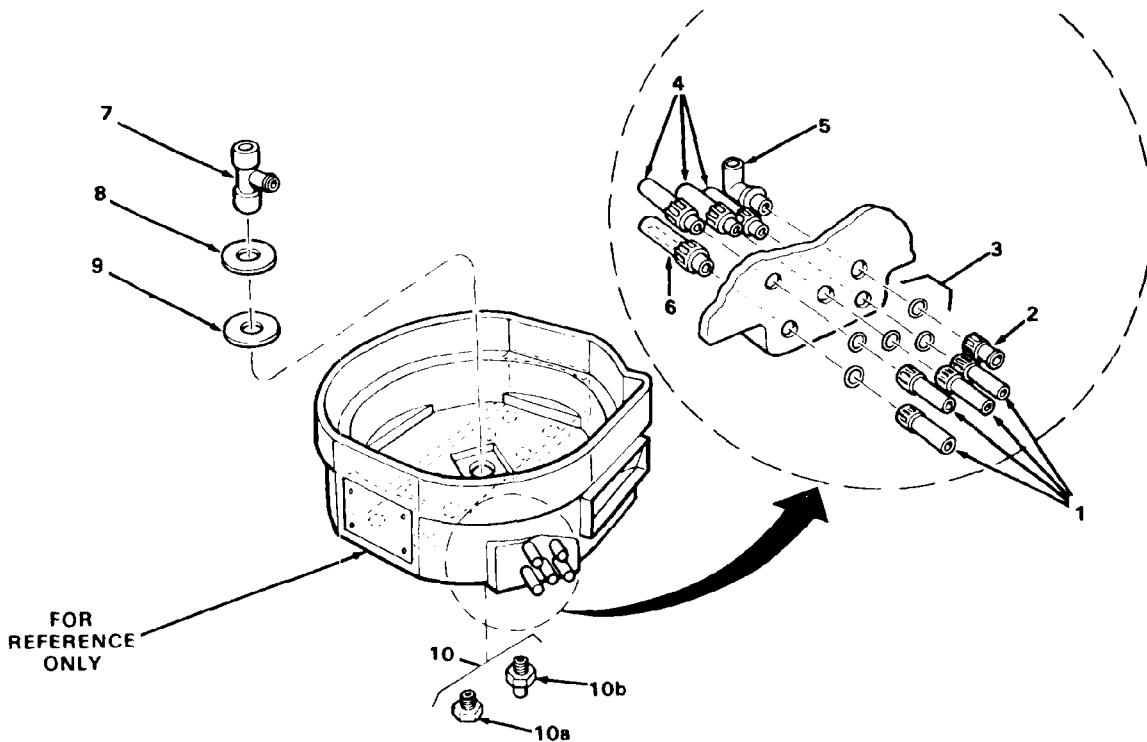

HC800 FREEZING CHAMBER — SUMP W/TUBES

ITEM NUMBER	PART NUMBER	DESCRIPTION	REQ'D NUMBER
NOTE: P/N A24819-001 shipped as replacement for both upper and lower Freezing Chamber, with Index 10a installed. For upper Freezing Chamber, also order Index 10b.			
1	02-2081-01	Tube, Female	4
2	A24379-001	Tube, Female - (Cut off)	1
3	13-0617-02	O-Ring	5
4	02-2080-01	Tube, Male	3
5	02-2125-01	Pipe, Stand	1
6	02-2082-01	Tube, Pick-Up - Pump	1
7	02-2121-01	Housing, Inlet	1
8	A23827-001	Plate, Support - Spray Bar	1
9	03-1409-11	Washer, Non-Metallic - 7/8-inch I.D.	1
10	No Number	Plug, Bottom	1
10a	02-2122-01	Plug, Bottom (Used in Lower Freezing Chamber)	Ref.
10b	A27197-002	Plug, Bottom (Used in Upper Freezing Chamber)	Ref.

HC800

PARTS ILLUSTRATIONS AND PARTS LISTS

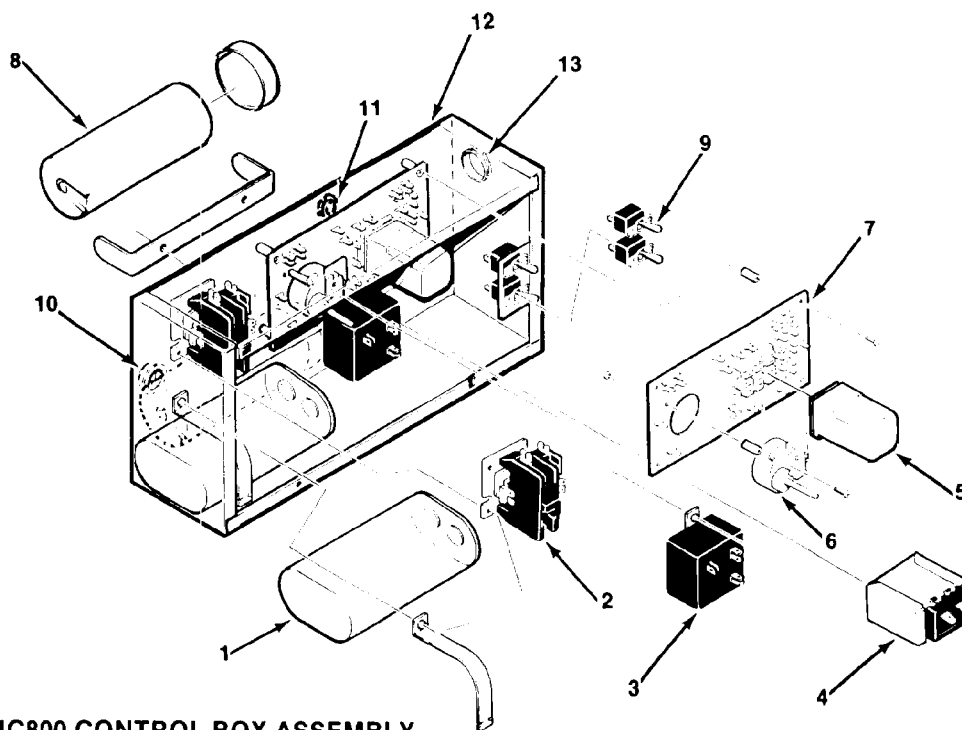

HC800 CONTROL BOX ASSEMBLY

ITEM NUMBER	PART NUMBER	DESCRIPTION
1	18-1902-51	Capacitor, Run 208-230/60/1
		Attaching Part, Index 1
	03-1403-17	Screw, No. 8-32 x 3/8 Phil Recess Pan Hd
2	12-0739-01	Contactor 208-220/60/3
	12-2037-01	Contactor 208-220/60/1
		Attaching Part, Index 2
	03-1403-17	Screw, No. 8-32 x 3/8 Phil Recess Pan Hd
3	18-1903-40	Relay, Potential 208-230/60/1
		Attaching Part, Index 3
	03-1403-04	Screw, No. 6-32 x 3/8 Phil Recess Pan Hd
	03-1423-01	Nut, Speed - J-Type
4	11-0388-02	Control, Pressure (Water-Cooled Only)
	11-0410-01	Control, Pressure (Air-Cooled Only)
		Attaching Part, Index 4
	03-1403-04	Screw, No. 6-32 x 3/8 Phil Recess Pan Hd
5	12-1879-02	Relay
6	12-1980-01	Timer & Switch Assembly
		Attaching Parts, Index 6
	02-2242-01	Stand-Off - 7/8-inch lg.
	03-1403-02	Screw, No. 6-32 x 1/4 Phil Recess Pan Hd
7	12-1912-01	Board Assembly, Circuit
		Attaching Parts, Index 7
	02-2242-01	Stand-Off - 7/8-inch lg.
	03-1403-02	Screw, No. 6-32 x 1/4 Phil Recess Pan Hd
8	18-1901-40	Capacitor, Start 208-230/60/1
9	12-0426-01	Switch, Toggle
10	<i>No Number</i>	Connector, Straight
11	12-1213-04	Bushing, Snap - 1/2-in.
12	12-1213-10	Bushing, Snap - 7/8-in.
13	12-1213-13	Bushing, Snap - 1-1/2-in.

HC800 WIRING DIAGRAMS

THIS UNIT MUST
BE GROUNDED

CAUTION: MORE THAN ONE DISCONNECT MEANS MAY BE
REQUIRED TO DISCONNECT ALL POWER TO THIS UNIT

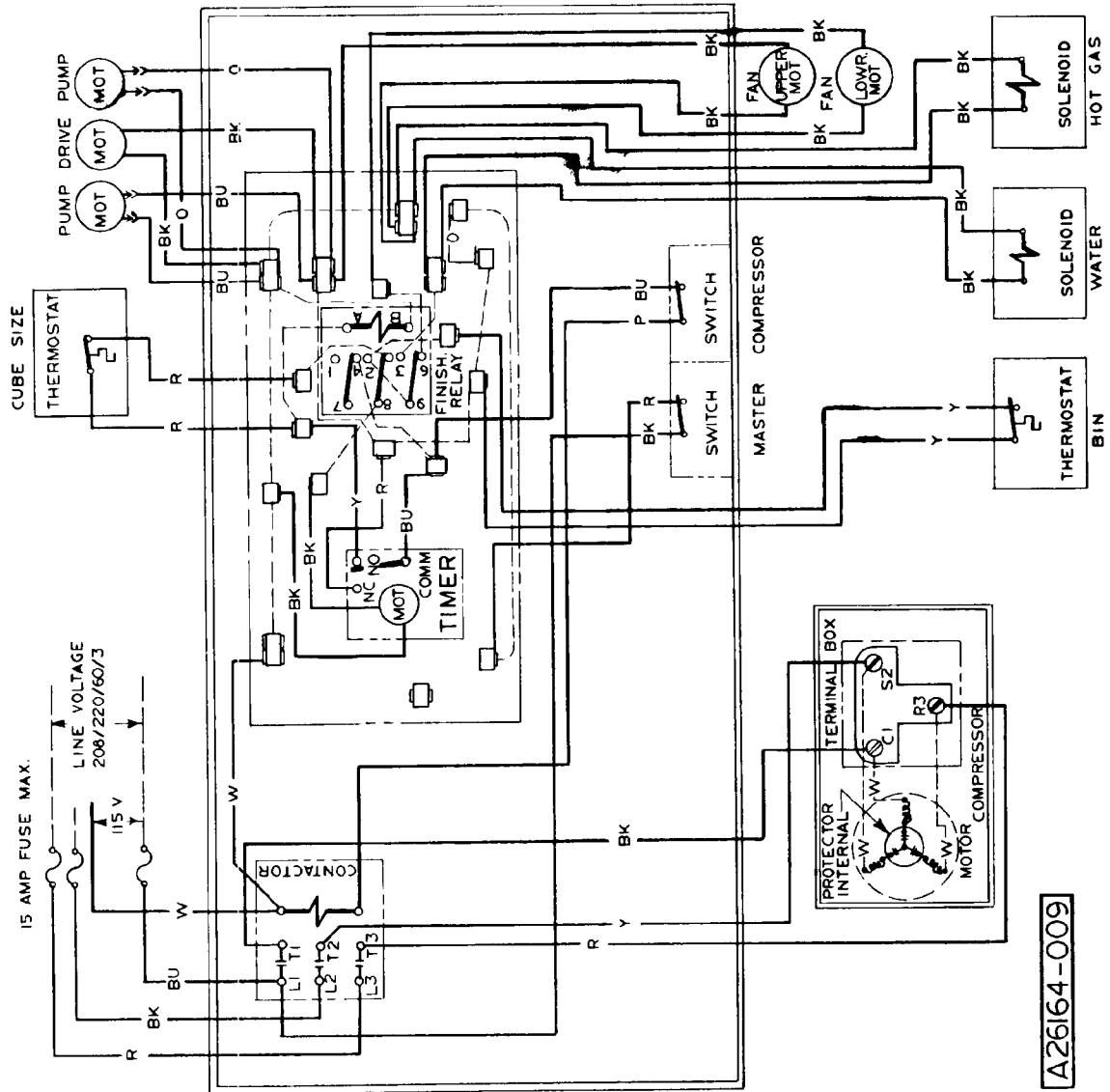
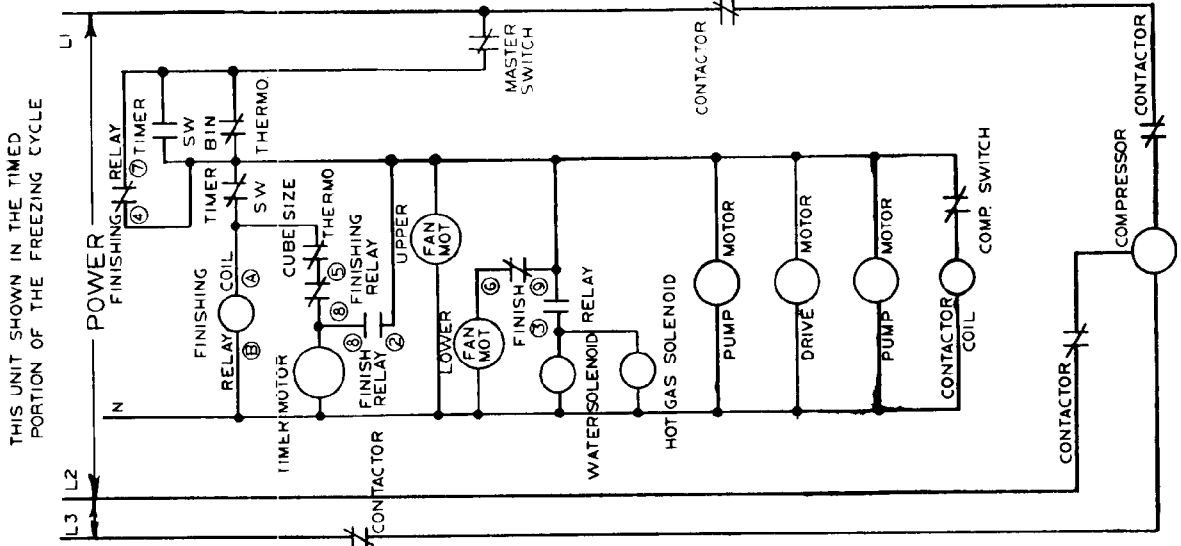

A26164-009

HC800AE-9A 115/208-220/60/3 — Air-Cooled

HC800 WIRING DIAGRAMS

THIS UNIT MUST
BE GROUNDED

**CAUTION: MORE THAN ONE DISCONNECT MEANS MAY BE
REQUIRED TO DISCONNECT ALL POWER TO THIS UNIT**

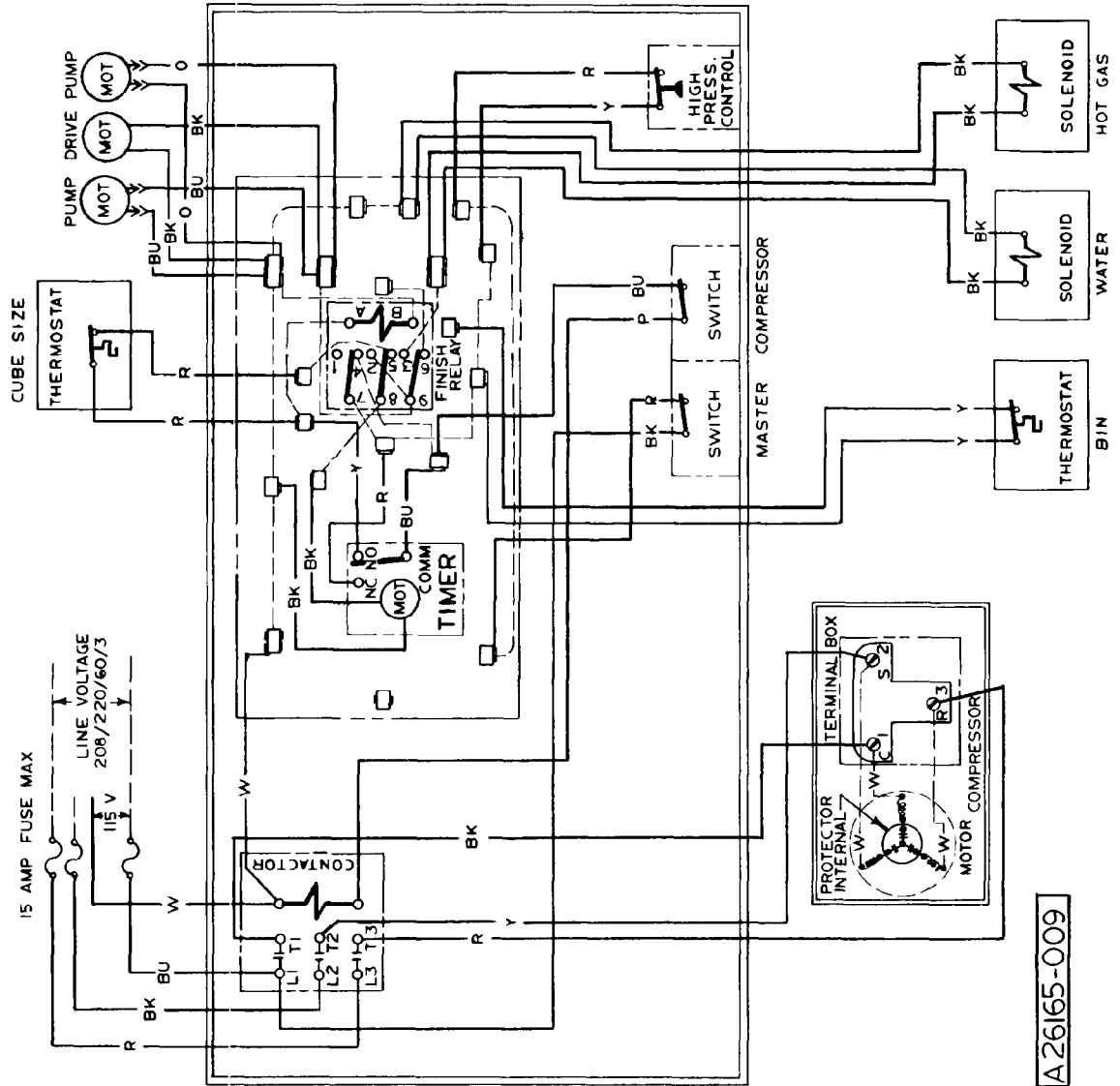
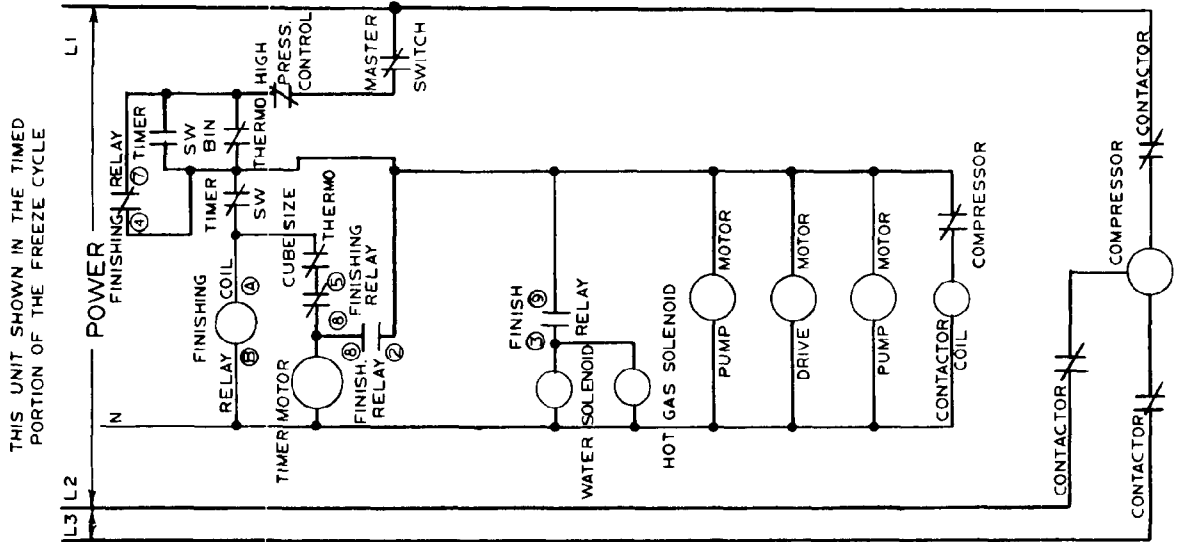

A26165-009

HC800AE-9A 115/208-220/60/3 — Water-Cooled

HC800 WIRING DIAGRAMS

THIS UNIT MUST
BE GROUNDED

THIS UNIT SHOWN IN THE TIMED
PORTION OF THE FREEZING CYCLE

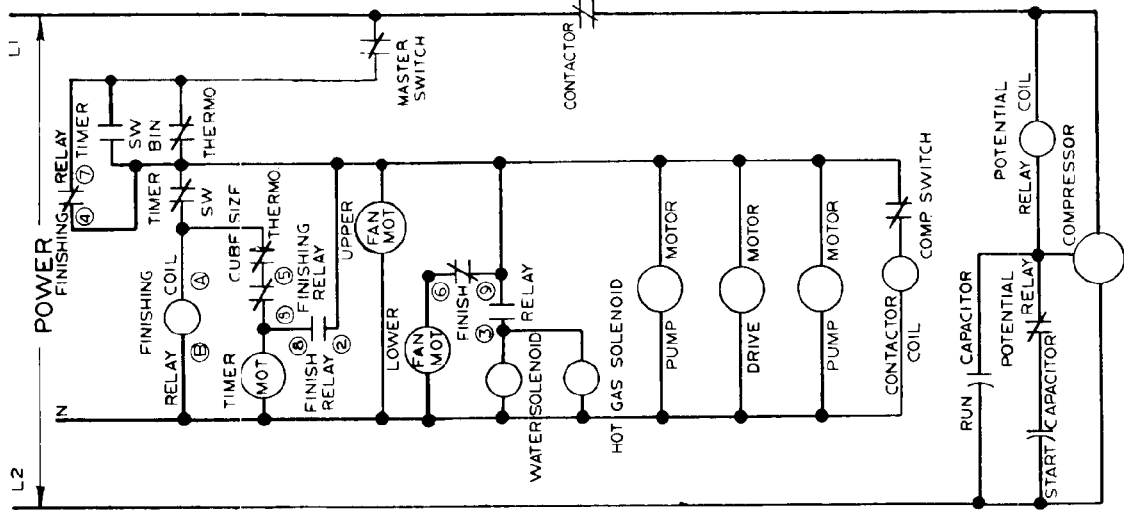

**CAUTION: MORE THAN ONE DISCONNECT MEANS MAY BE
REQUIRED TO DISCONNECT ALL POWER TO THIS UNIT**

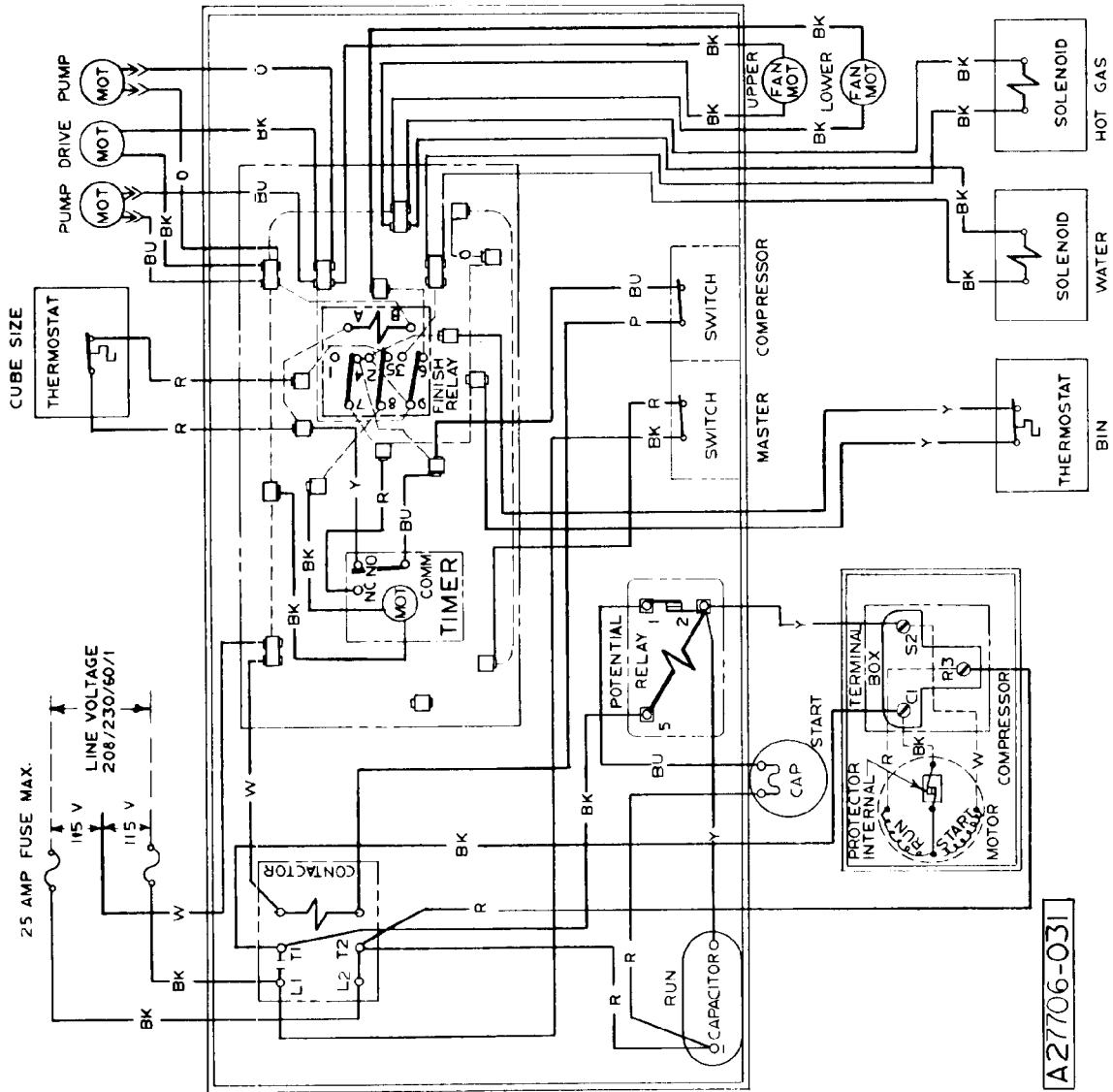

HC800AE-31A 115/208-230/60/1 — Air-Cooled

HC800 WIRING DIAGRAMS

THIS UNIT MUST
BE GROUNDED

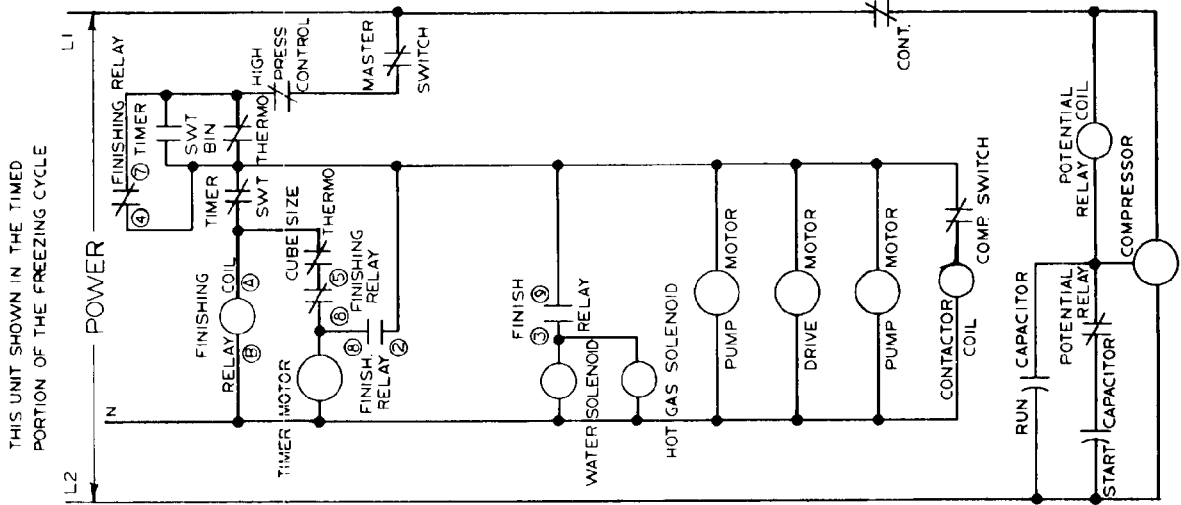

CAUTION: MORE THAN ONE DISCONNECT MEANS MAY BE
REQUIRED TO DISCONNECT ALL POWER TO THIS UNIT

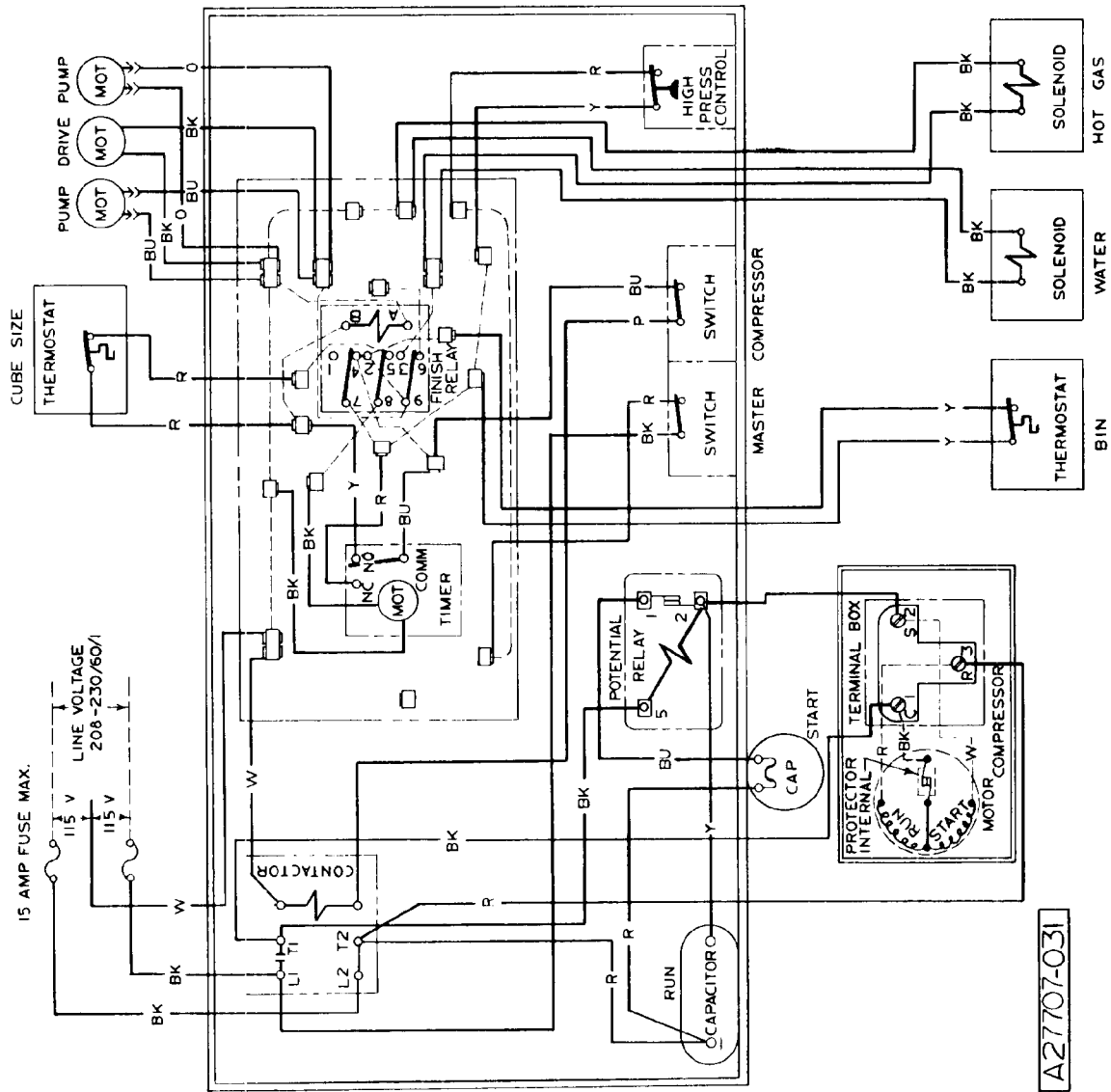

A27707-031

HC8C0AE-31A 115/208-230/60/1 — Water-Cooled