

HQD750 Parts List

Table of Contents

Cabinet

Air Cooled

Water Cooled

Compressor

Water System

Elbow & Switch

Dispensing Bin

Bin Level Control

Dispensing Levers

Shutter

Evaporator

Drive Motor

Control Box

Wiring Diagrams

HQD750 THE PARTS ILLUSTRATIONS AND PARTS LISTS

GENERAL

This section contains the Parts Illustrations and the Parts List for each of the major assemblies in the HQD750 High Quality Ice Dispenser.

A *No Number* designation, when used in the Part Number Column indicates the unit is not available from SCOTSMAN as an assembly. This designation is used only for the convenience and clarity of division in cataloging.

HOW TO ORDER PARTS OR ASSEMBLIES

When ordering parts or assemblies, to avoid costly delays and errors in shipment, give the part number, the complete description shown in the list, and the quantities of each part or assembly required. Also include the model name, the serial number of the icemaker for which the part is required and for parts which require color matching, the color of the cabinet.

All part numbers have TEN DIGITS (spaces), required for use in the Computer System. BE SURE to fill in ALL SPACES in the CATALOG NUMBER column, on the parts order form.

Model HQD750's have been manufactured in A through C Models. As in HQD750AE-1A vs. HQD750AE-1C. Refer to the complete model number to obtain the correct part number.

WIRING DIAGRAMS

This section is provided as an aid in understanding the electrical circuitry of the HQD750 High Quality Ice Dispenser.

The wiring diagrams in this Section are:

- HQD750AE-1A (115/60/1)
- HQD750WE-1A (115/60/1)
- HQD750AE-1C (115/60/1)
- HQD750WE-1C (115/60/1)

//////////////////// **WARNING** //////////////////////

When conducting a continuity check of the modular cuber:

- 1. Disconnect the main power source.**
- 2. DO NOT use an incandescent lamp or jumper wire, conduct all tests with a volt-ohm-meter.**

////////////////////////////////////

HQD750 THE PARTS ILLUSTRATIONS AND PARTS LISTS

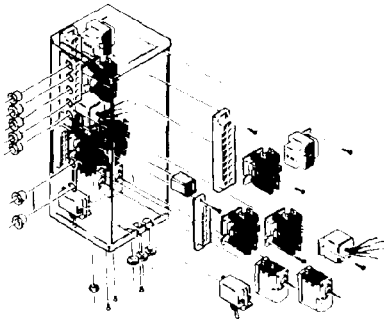

CONTROL BOX ASSEMBLY

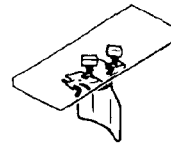

**BIN ICE LEVEL
AND
SHUT DOWN
SWITCHES**

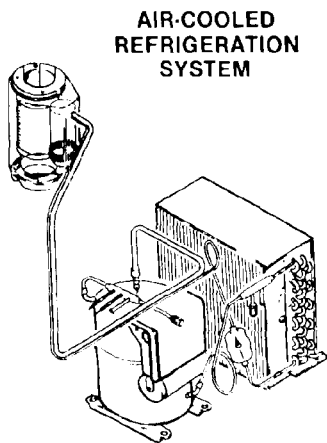
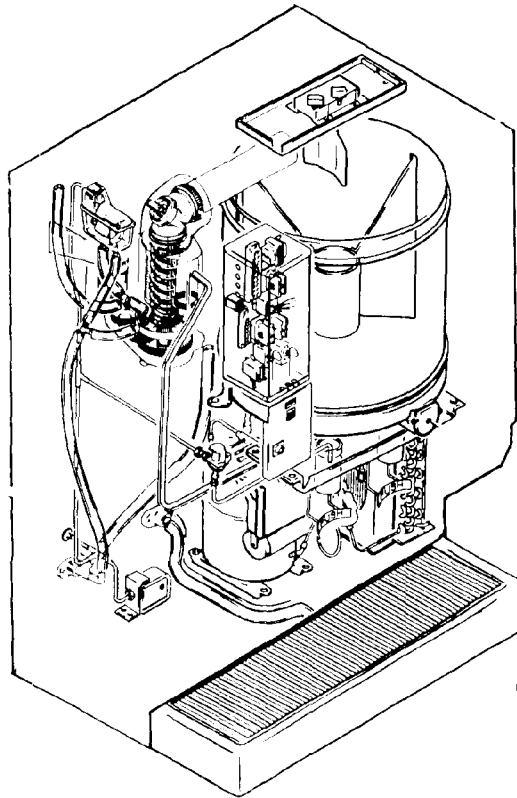

**AIR-COOLED
REFRIGERATION
SYSTEM**

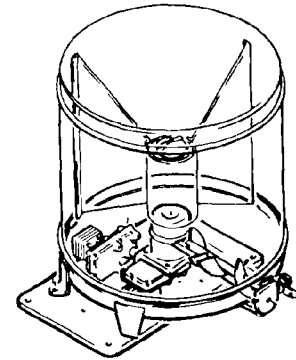

BIN ASSEMBLY

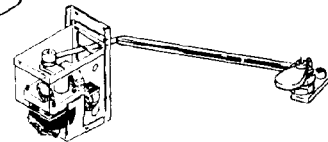

**SHUTTER ACTUATOR
ASSEMBLY**

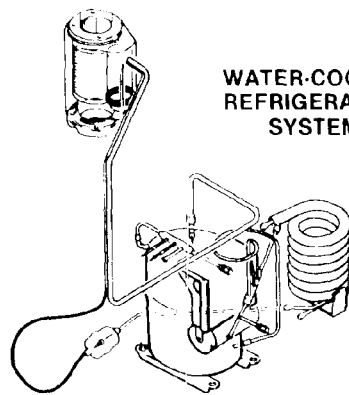

**WATER-COOLED
REFRIGERATION
SYSTEM**

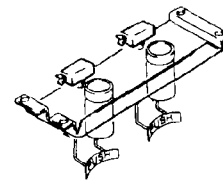

DISPENSER ASSEMBLY

HQD750 THE PARTS ILLUSTRATIONS AND PARTS LISTS

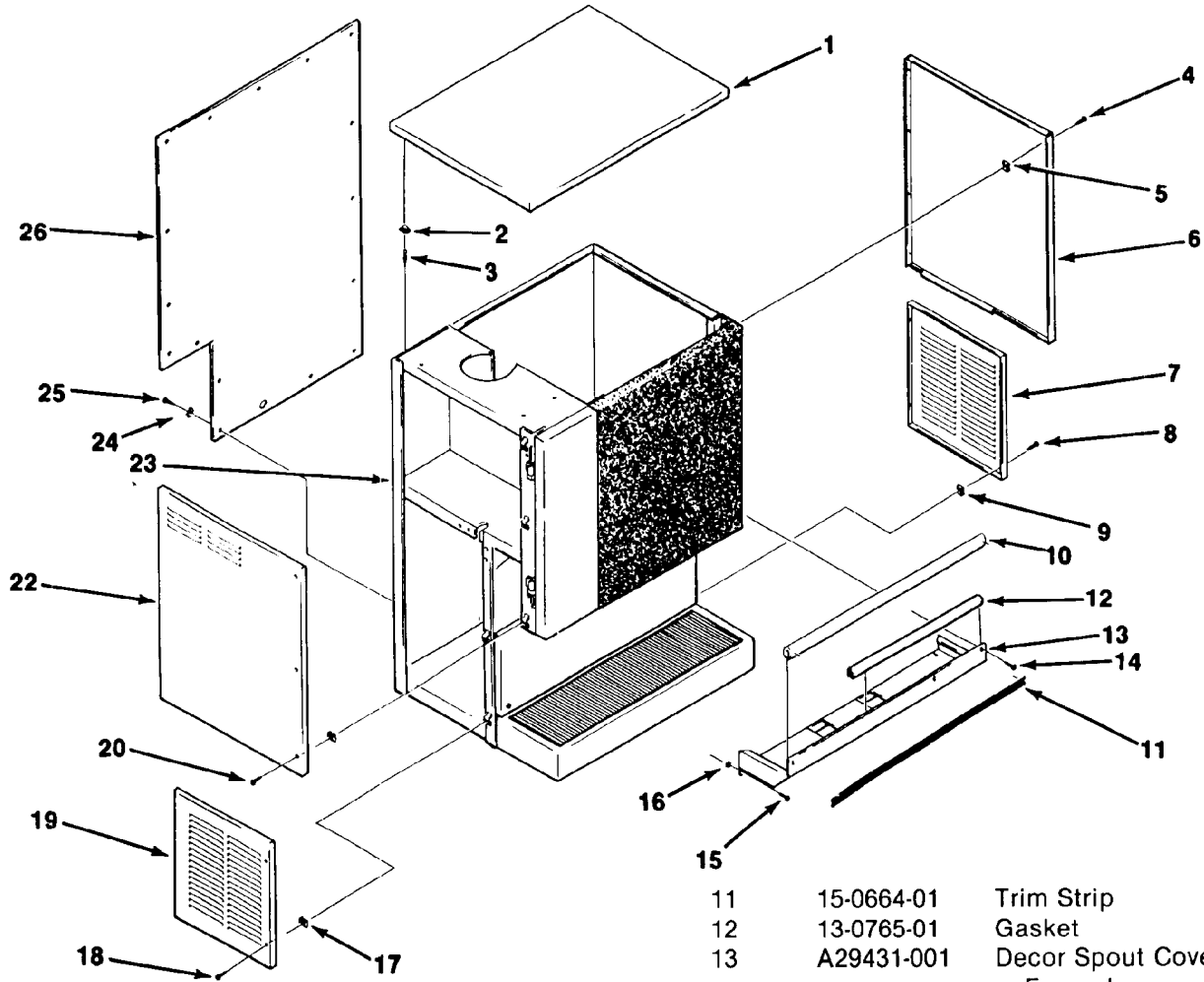

CABINET ASSEMBLY I

ITEM NUMBER	PART NUMBER	DESCRIPTION
1	A29534-004	Top Panel, Enamel
	A29534-001	Top Panel, Stainless Steel
2	02-0836-00	Catch
3	15-0411-00	Strike
4	03-1418-07	Screw
5	03-1507-01	Speednut
6	A24852-005	Side Panel (Right), Enamel
	A24852-002	Side Panel (Right), Stainless Steel
7	A24837-010	Lower Side Panel (Right), Enamel
	A24837-004	Lower Side Panel (Right), Stainless Steel
8	03-1419-17	Screw
9	03-1507-01	Speednut
10	A25436-001	Trim Channel

11	15-0664-01	Trim Strip
12	13-0765-01	Gasket
13	A29431-001	Decor Spout Cover, Enamel
	A29431-002	Decor Spout Cover, Stainless Steel
14	03-1403-29	Screw
15	03-1403-29	Screw
16	03-1406-05	Nut
17	03-1507-01	Speednut
18	03-1419-17	Screw
19	A24837-009	Lower Side Panel (Left), Enamel
	A24837-003	Lower Side Panel (Left), Stainless Steel
20	03-1419-17	Screw
21	03-1507-01	Speednut
22	A24853-005	Side Panel (Left), Enamel
	A24853-002	Side Panel (Left), Stainless Steel
23	No Number	Frame
24	03-1417-09	Lockwasher, #1/4
25	03-1403-47	Screw, #1/4-20 x 1/2
26	A32334-001	Back Panel, Enamel
	A32334-002	Back Panel, Stainless Steel

HQD750 THE PARTS ILLUSTRATIONS AND PARTS LISTS

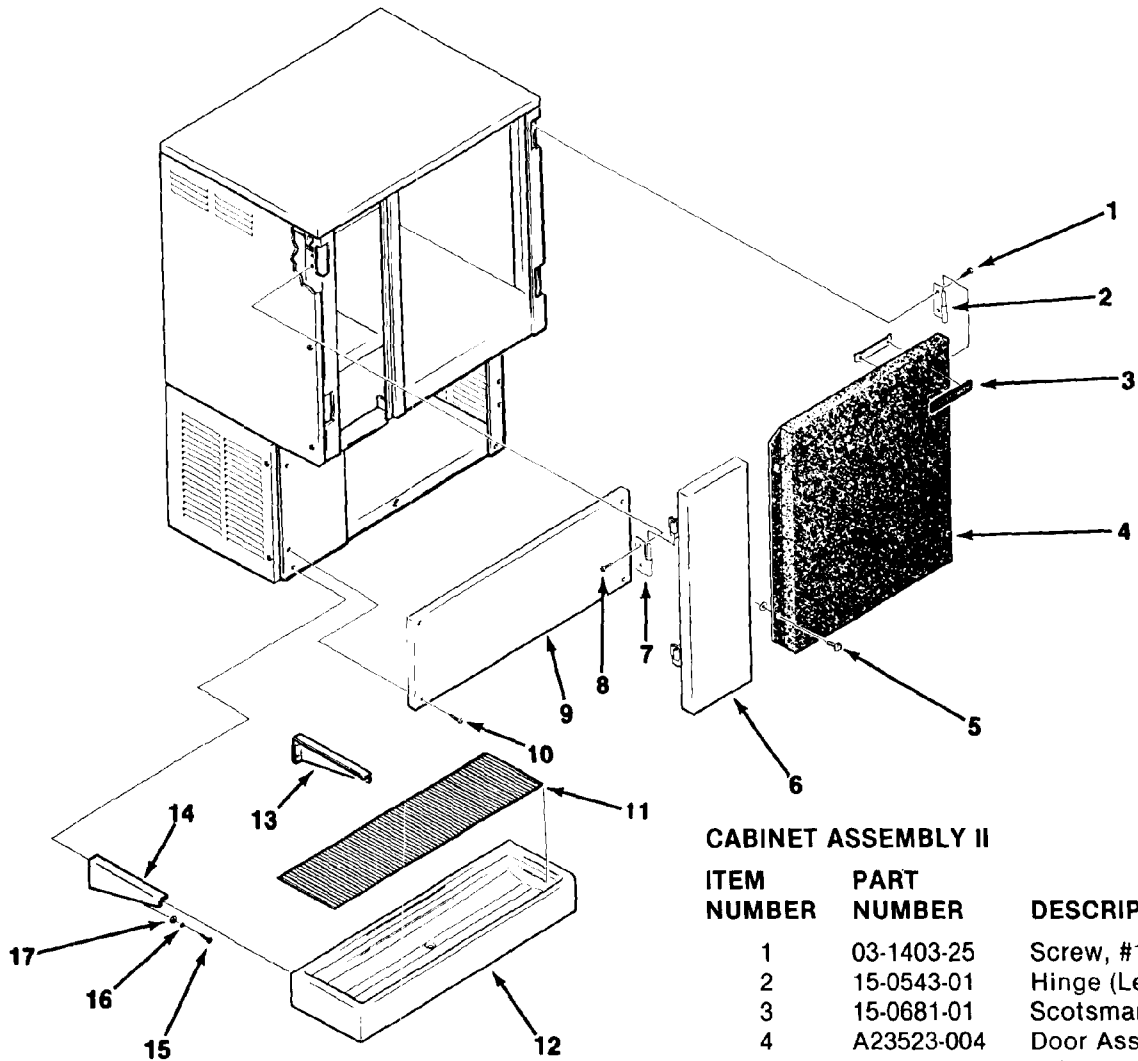

CABINET ASSEMBLY II

ITEM NUMBER	PART NUMBER	DESCRIPTION
1	03-1403-25	Screw, #10-24 x 1/4
2	15-0543-01	Hinge (Left) (2)
3	15-0681-01	Scotsman Emblem
4	A23523-004	Door Assembly, Enamel
	A23523-005	Door Assembly, Stainless Steel
5	03-1418-07	Screw
6	A23702-005	Panel Assembly (Front), Enamel
	A23702-002	Panel Assembly (Front), Stainless Steel
7	15-0543-03	Hinge (Right) (2)
8	03-1403-25	Screw, #10-24 x 1/4
9	A29422-001	Backsplash Assembly
10	03-1418-11	Screw #10-24 x 1
11	02-2582-01	Grill
12	A31047-001	Sink Assembly
13	A23704-002	Sink Support (Right)
14	A23704-001	Sink Support (Left)
15	03-1403-47	Screw, #1/4-20 x 1/2
16	03-1407-05	Washer, #1/4 Flat
17	03-1410-03	Lockwasher, #1/4 Helical Spring

HQD750 THE PARTS ILLUSTRATIONS AND PARTS LISTS

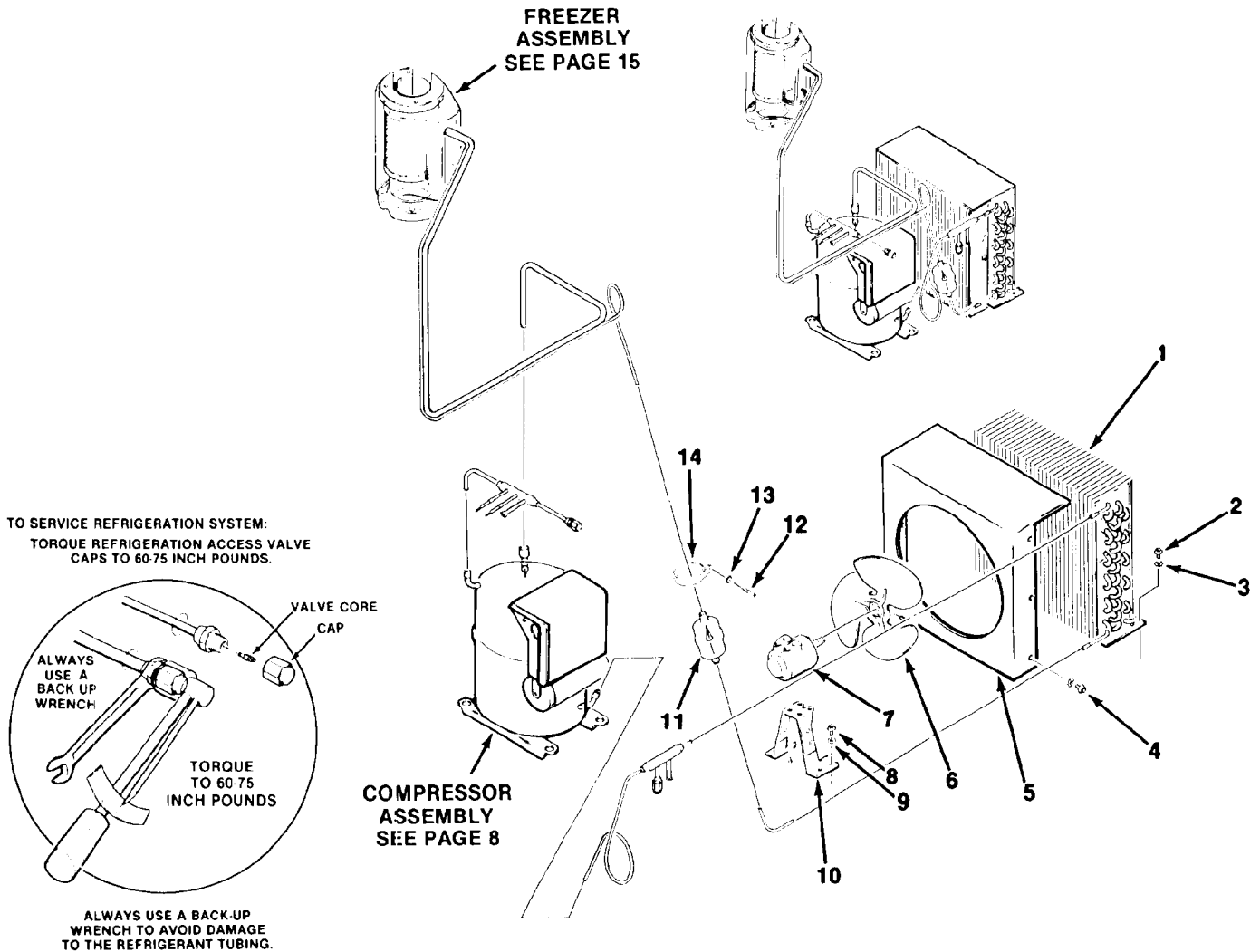

AIR-COOLED ASSEMBLY

ITEM NUMBER	PART NUMBER	DESCRIPTION
1	18-0396-01	Condenser
2	03-0571-00	Screw, #1/4-20 x 1/2
3	03-1417-09	Lockwasher, #1/4
4	03-1404-03	Screw, #6-32 x 1/4
5	02-2352-01	Fan Shroud
6	18-0363-00	Fan Blade
7	12-1576-01	Fan Motor
8	03-0571-00	Screw, #1/4-20 x 1/2
9	03-1417-09	Lockwasher, #1/4
10	A25548-001	Fan Motor Bracket
11	02-0544-01	Drier
12	03-1403-16	Screw #8-32 x 3/8
13	03-1406-03	Nut, #8-32
14	A29117-001	Drier Brace

HQD750 THE PARTS ILLUSTRATIONS AND PARTS LISTS

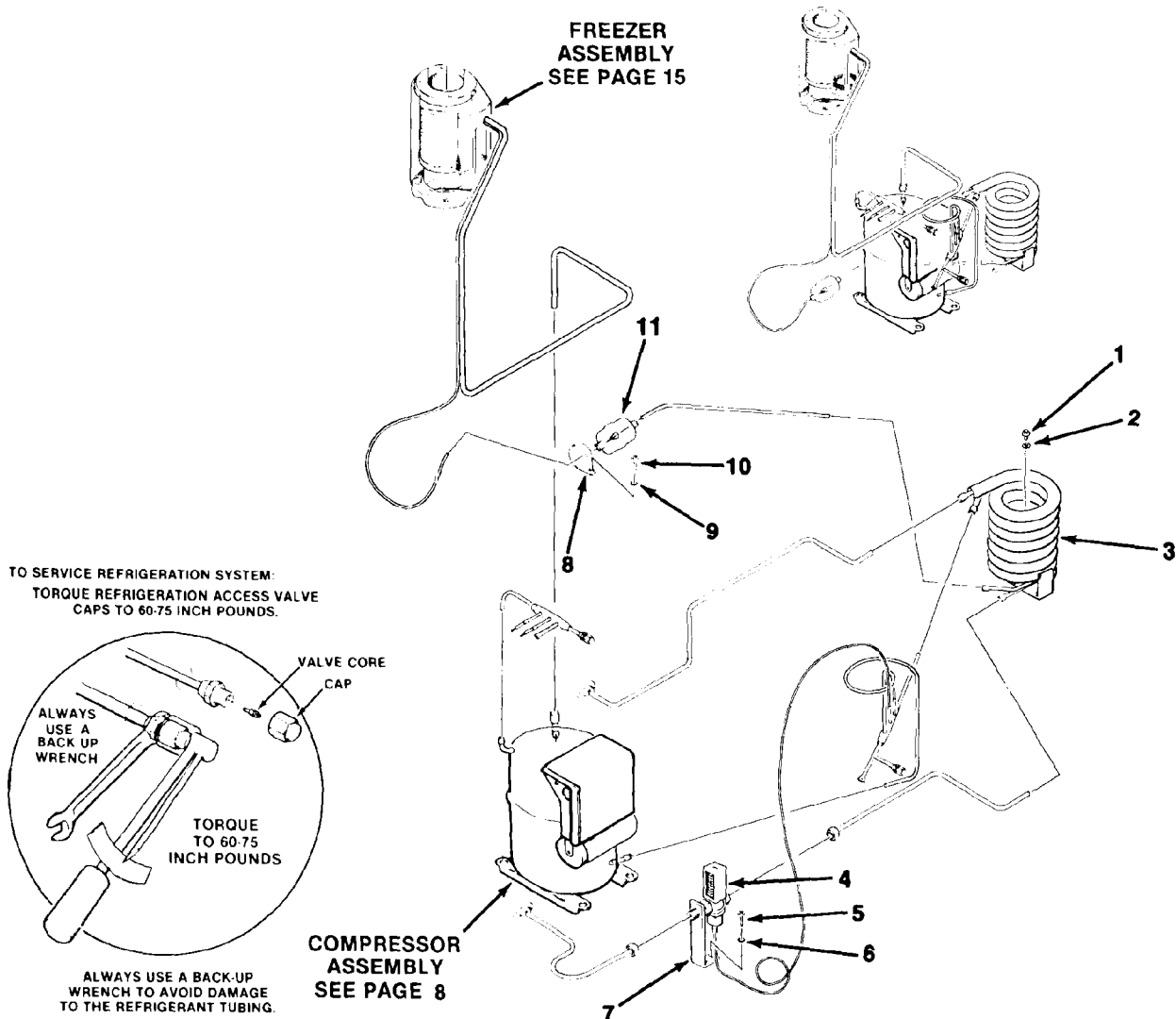

WATER-COOLED ASSEMBLY

ITEM NUMBER	PART NUMBER	DESCRIPTION
1	03-0571-00	Screw, #1/4-20 x 1/2
2	03-1417-09	Lockwasher, #1/4
3	18-3305-02	Condenser
4	11-0198-02	Water Regulator Assembly
5	03-0571-00	Screw, #1/4-20 x 1/2
6	03-1417-09	Lockwasher, #1/4
7	A15924-000	Brace - Nipple Assembly
8	A09388-000	Drier Brace
9	No Number	Screw, #1/4-20 x 3/4
10	No Number	Lockwasher, #1/4
11	02-0544-01	Drier

HQD750 THE PARTS ILLUSTRATIONS AND PARTS LISTS

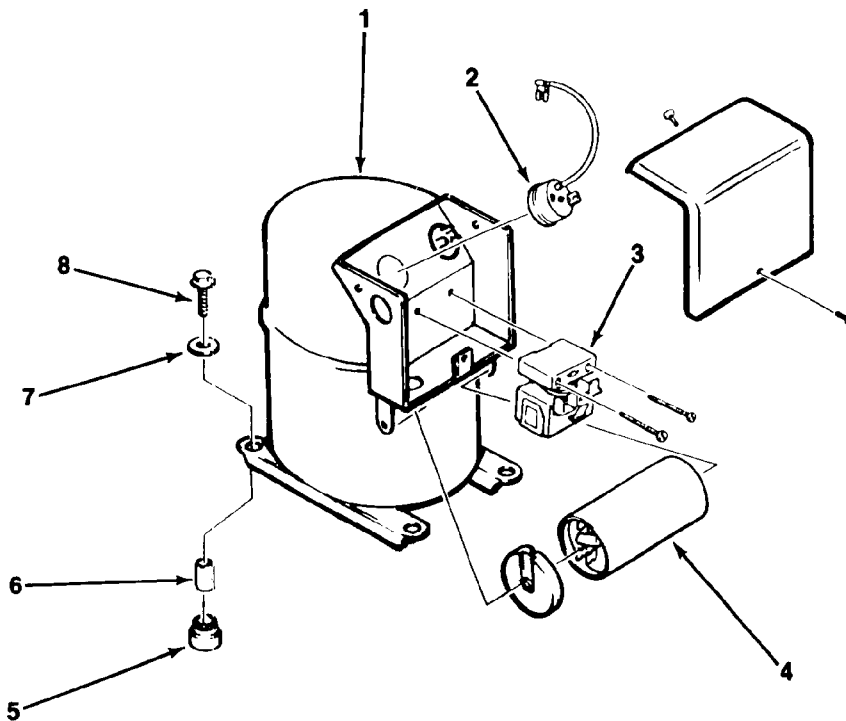

COMPRESSOR ASSEMBLY

ITEM NUMBER	PART NUMBER	DESCRIPTION
1	18-3900-01	Compressor (115/60/1)
2	18-2400-25	Overload (115/60/1)
3	18-2410-00	Relay (115/60/1)
4	18-1901-42	Capacitor (115/60/1)
5	18-2200-28	Mounting Grommet
6	18-2200-27	Mounting Sleeve
7	03-1407-07	Plain Washer
8	03-1406-01	Hex Nut

HQD750 THE PARTS ILLUSTRATIONS AND PARTS LISTS

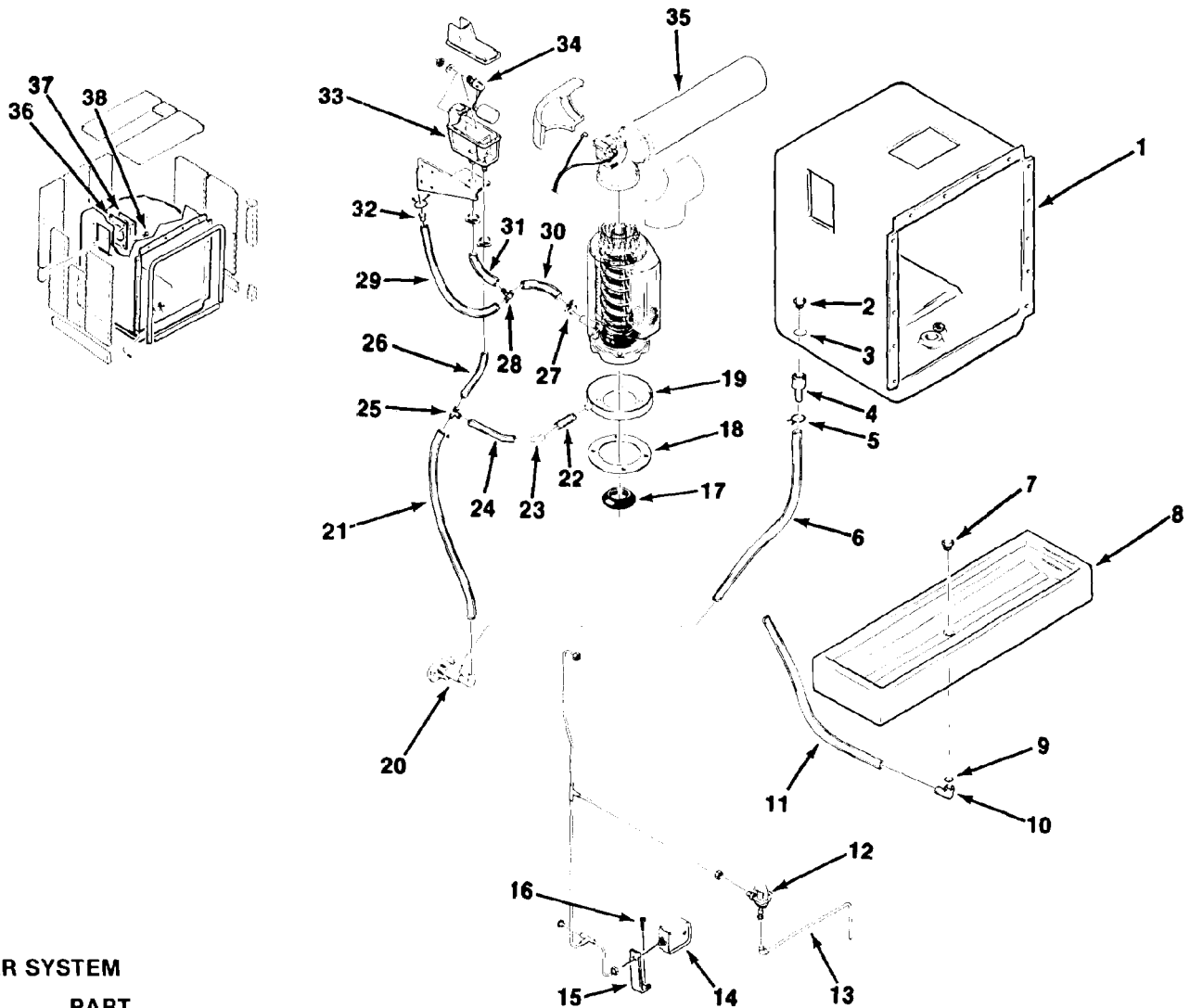

WATER SYSTEM

ITEM NUMBER	PART NUMBER	DESCRIPTION
1	A29424-020	Upper Compartment
2	02-1751-00	Drain top
3	13-0617-13	O-ring
4	02-1957-00	Drain bottom
5	02-1338-00	Clamp
6	13-0079-01	Drain tube, 18"
7	02-2809-01	Drain top (Sink)
8	A31047-001	Sink
9	13-0617-11	O-ring
10	02-1742-00	Elbow
11	13-0079-01	Drain tube, 18"
12	12-1646-09	Water Solenoid Assembly
13	No Number	Water Tube
14	11-0296-00	Lo Pressure Control
15	No Number	Bracket
16	03-0571-00	Screw, #1/4-20 x 1/2
17	A31340-001	Water Shed - C Model
18	13-0704-00	Gasket
19	A24156-002	Drip Pan - C Model
20	A32294-001	Drain Fitting - C Model
21	13-0079-03	Drain tube
22	13-0079-03	Drain tube, 1.25"
23	16-0617-02	Elbow
24	13-0079-03	Drain tube, 13"
25	16-0670-02	Tee
26	13-0079-03	Drain tube, 11"
27	02-0694-00	Clamp
28	16-0670-02	Tee
29	13-0674-09	Hose, 16" - C Model
30	13-0674-09	Hose, 2"
31	13-0674-09	Hose, Reservoir 3"
32	No Number	Plug
33	02-2217-01	Reservoir
34	02-2217-02	Float Valve Assembly
35	A30229-001	Spout Assembly
36	A29494-001	Spout Entry Plate
37	A29493-001	Spout Mounting Plate
38	03-1403-27	Screw, "10-24 x 3/8

HQD750 THE PARTS ILLUSTRATIONS AND PARTS LISTS

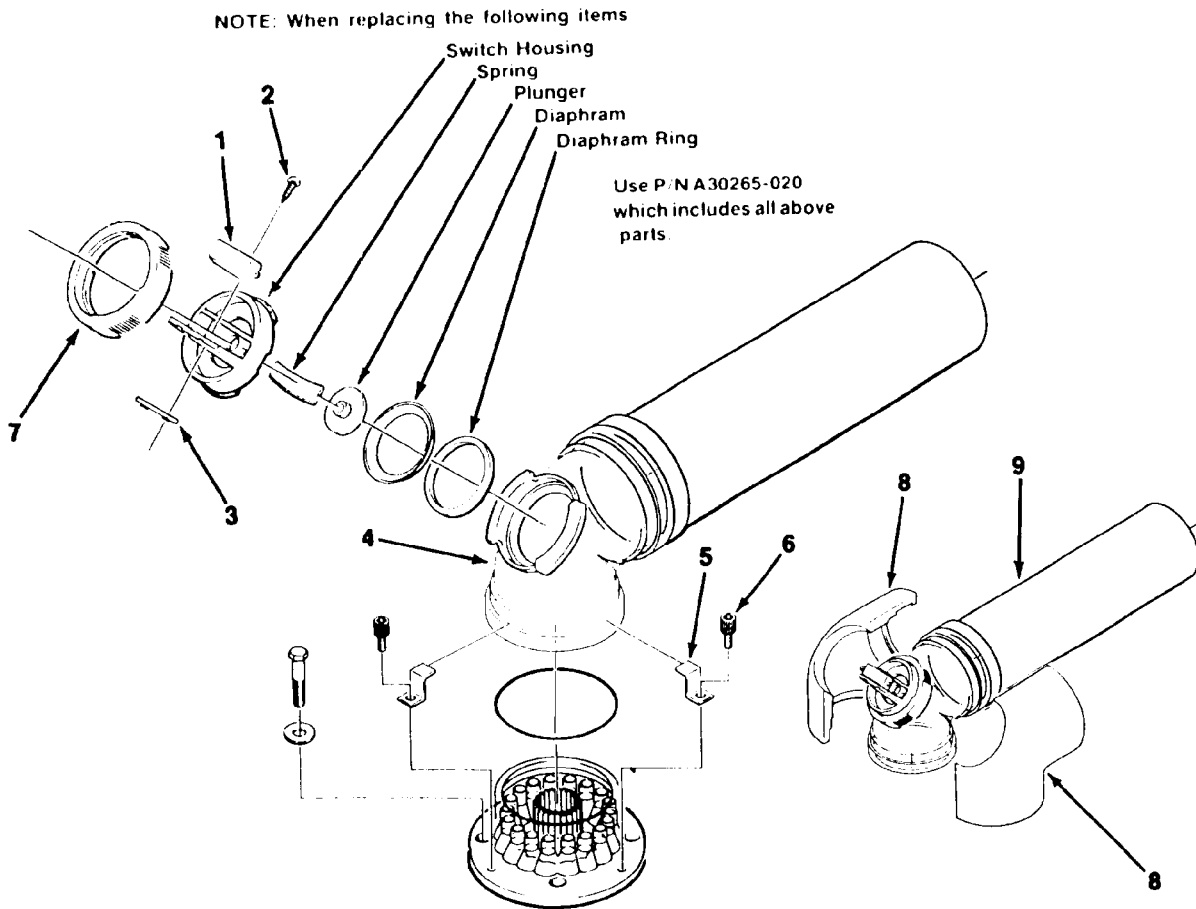

ELBOW AND SWITCH ASSEMBLY

ITEM NUMBER	PART NUMBER	DESCRIPTION
1	12-2202-01	Switch
2	03-1403-08	Screw, #6-32 x 7/8
3	03-0886-00	Speednut
4	02-2764-01	Elbow Assembly
5	02-2604-01	Bracket, Spout Retaining
6	03-1544-04	Screw, #10-24 x 3/8 Stainless Soc HD Cap
7	02-2637-01	Retaining Ring
8	A31390-001	Insulation - Includes left and right sides
9	A30229-001	Ice Tube Assembly Complete

HQD750 THE PARTS ILLUSTRATIONS AND PARTS LISTS

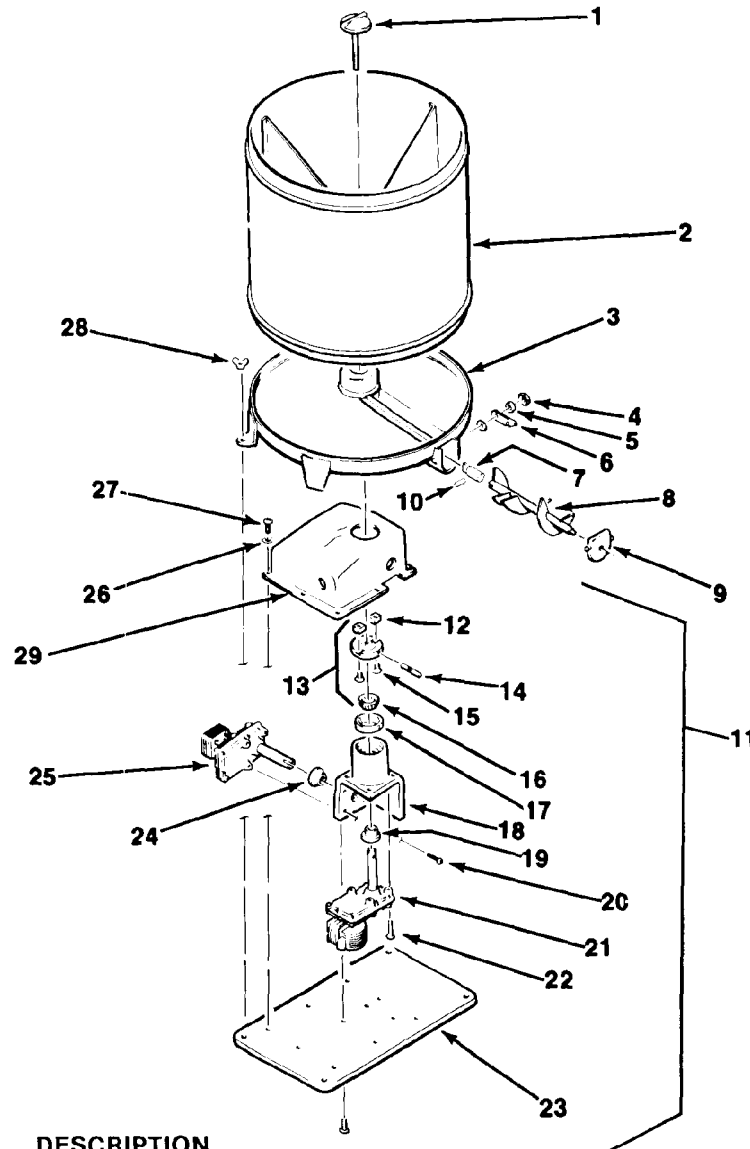

BIN ASSEMBLY

ITEM NUMBER	PART NUMBER	DESCRIPTION
1	02-1587-00	Cap Nut
2	A14945-000	Storage Bin Cylinder
3	A24294-001	Bin Bottom
4	03-1129-00	Cap Nut
5	03-1408-09	Washer
6	A14932-000	Chute Lock
7	A14573-000	Drive End - Auger
8	A30128-001	Auger Assembly
9	A14933-000	End Plate
10	03-1552-01	Pin - Drive End
11	A24095-001	Drive Unit Assembly Complete
12	02-2720-01	Key (2)
13	A28085-001	Hub Drive (Contains Items #12, 13, 15, 16)
14	A24094-001	Pin
15	03-1418-13	Screw
16	02-2186-02	Bearing Cone
17	02-2186-01	Bearing Cup
18	A28084-001	Bin Support Assembly (Contains Items #17, 18, 19)
19	02-1461-00	Bearing
20	03-1403-70	Screw
21	12-1850-01	Bin Drive Motor
22	03-1403-70	Screw
23	A23841-001	Mounting Plate
24	02-1461-00	Bearing
25	12-1851-01	Auger Drive Motor
26	03-1407-02	Washer
27	03-1403-16	Screw
28	03-0255-03	Wing Nut
29	02-2049-01	Motor Cover

HQD750 THE PARTS ILLUSTRATIONS AND PARTS LISTS

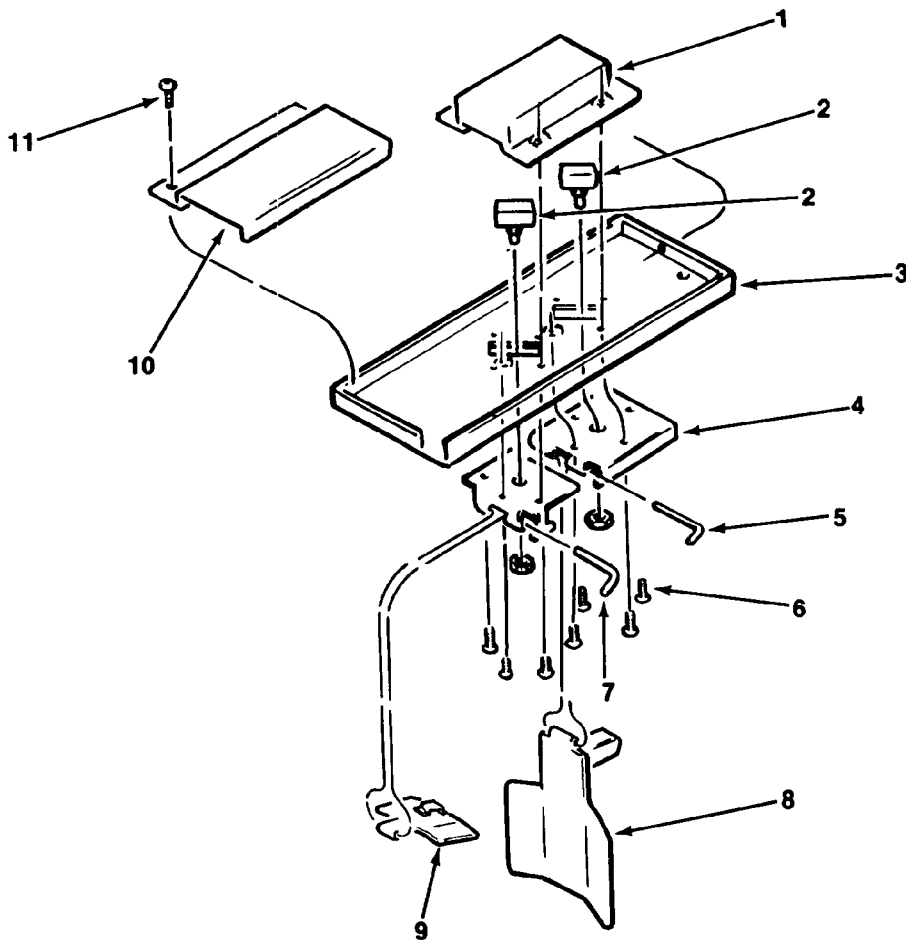

BIN ICE LEVEL ASSEMBLY

ITEM NUMBER	PART NUMBER	DESCRIPTION
1	No Number	Switch Cover
2	12-1018-01	Micro-Switch
3	No Number	Channel Support
4	A16882-000	Top Hinge
5	A16885-000	Hinge Pin
6	03-1403-27	Screw
7	A29508-001	Hinge Pin
8	A16883-000	Bottom Assembly Hinge (ice level control)
9	A29514-001	Switch Actuator Plate
10	No Number	Channel Cover
11	No Number	Screw, #10 x 1/2

HQD750 THE PARTS ILLUSTRATIONS AND PARTS LISTS

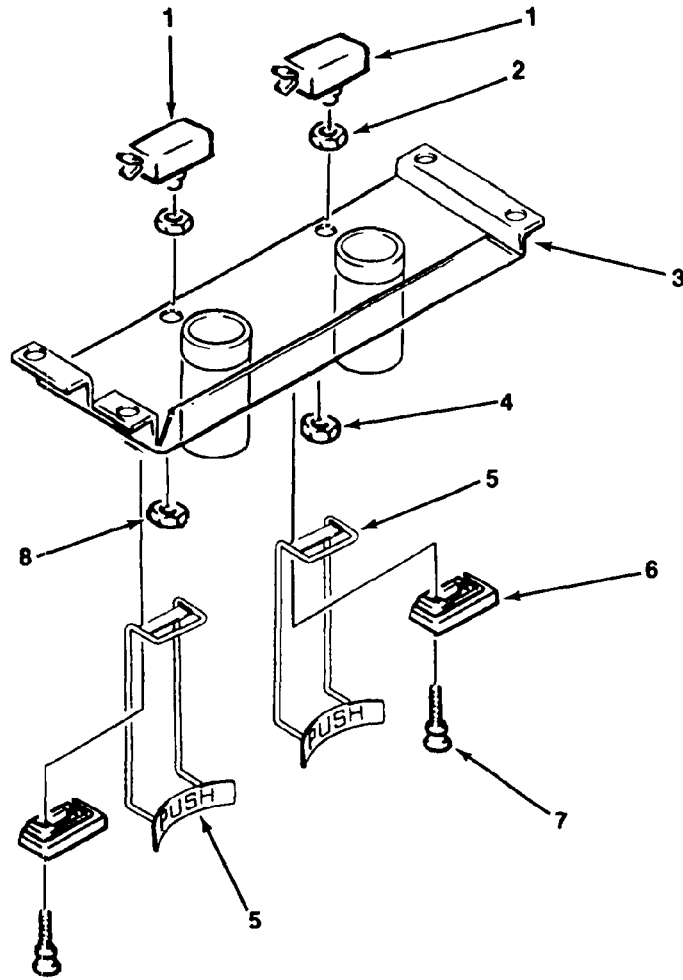

DISPENSER ASSEMBLY

ITEM NUMBER	PART NUMBER	DESCRIPTION
1	12-1570-00	Switch
2	No Number	Nut (Included with Switch)
3	A30409-001	Mounting Bracket
4	No Number	Nut (Included with Switch)
5	02-2581-01	Actuator Arm Assembly
6	A22032-000	Adaptor
7	03-0727-08	Thumb Screw
8	No Number	Nut (Included with Switch)

HQD750 THE PARTS ILLUSTRATIONS AND PARTS LISTS

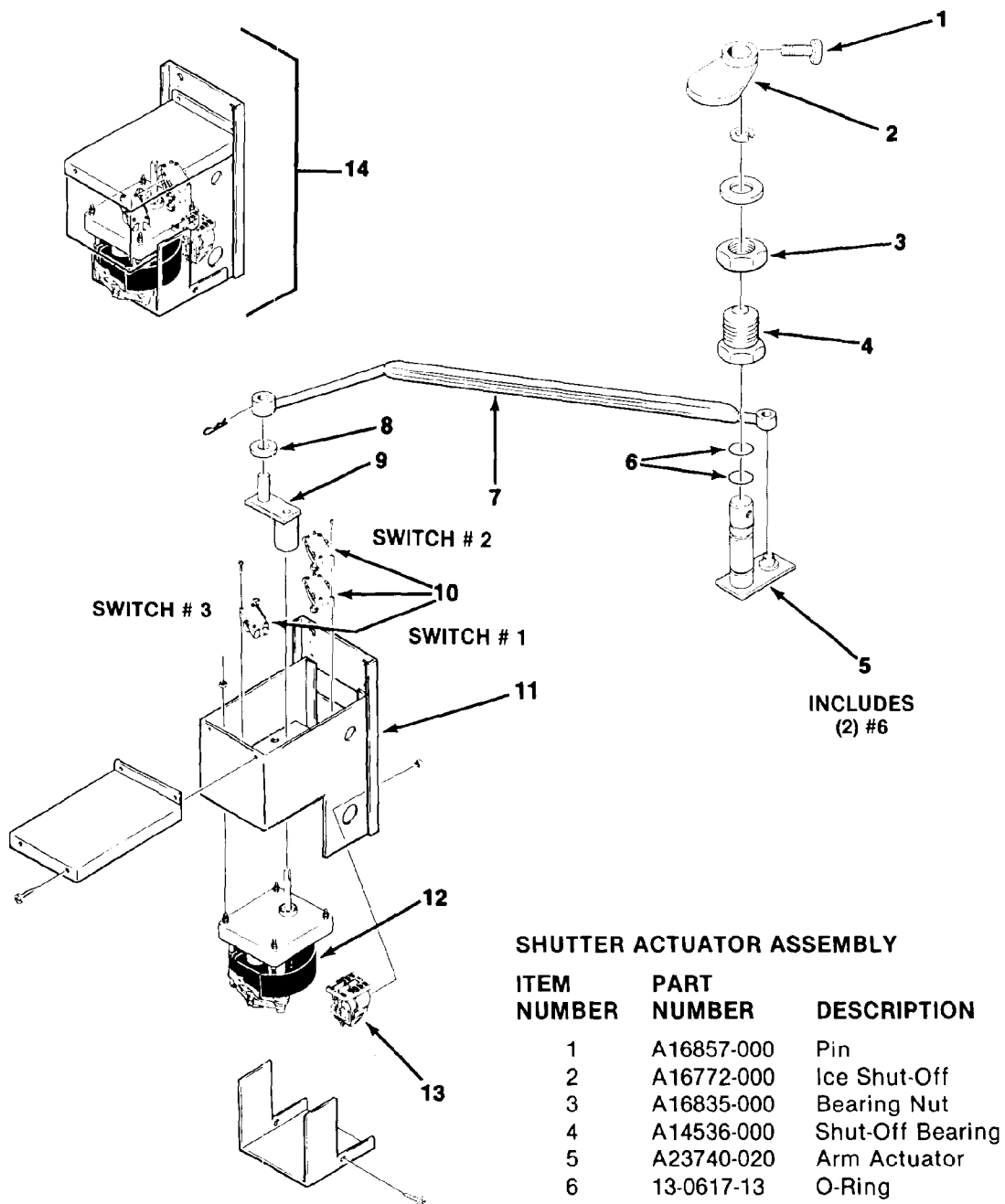

SHUTTER ACTUATOR ASSEMBLY

ITEM NUMBER	PART NUMBER	DESCRIPTION
1	A16857-000	Pin
2	A16772-000	Ice Shut-Off
3	A16835-000	Bearing Nut
4	A14536-000	Shut-Off Bearing
5	A23740-020	Arm Actuator
6	13-0617-13	O-Ring
7	A23692-001	Actuator Rod
8	03-1407-09	Washer, 3/8
9	A24356-001	Actuator Cam
10	12-1614-00	Switch
11	A21220-000	Motor Mount
12	12-1613-00	Gear Motor
13	12-1467-00	Relay
14	A23738-001	Shutter Actuator Assembly (Complete)

HQD750 THE PARTS ILLUSTRATIONS AND PARTS LISTS

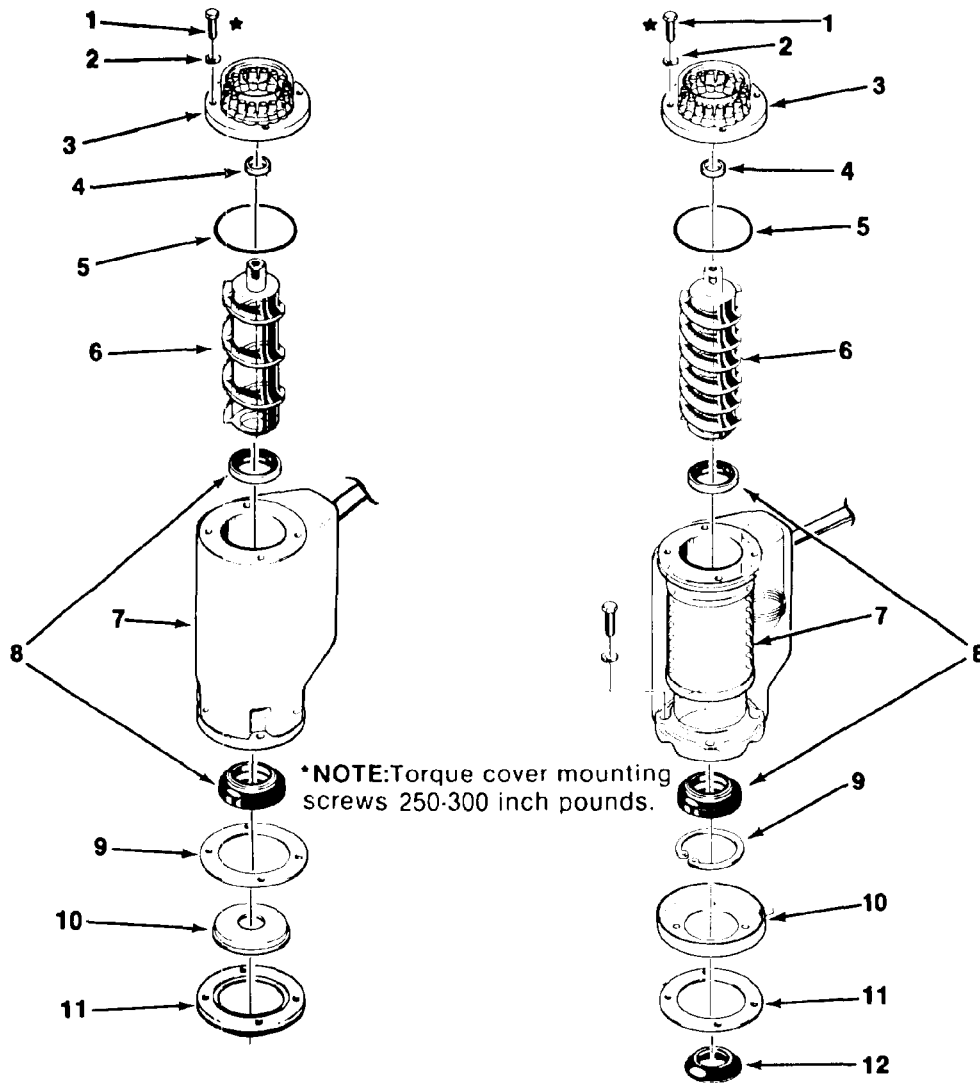

FREEZER ASSEMBLY (A & B MODELS ONLY)

ITEM NUMBER	PART NUMBER	DESCRIPTION
1	03-1405-42	Screw, No. 5/16 - 18 x 7/8 Hex Cap
2	03-1417-13	Lockwasher, No. 5/16 Helical Spring
3	A32571-020	Ice Breaker (Includes Bearing & Seal)
4	02-2853-01	Seal
5	13-0617-46	O-Ring
6	A31839-001	Auger
7	A32431-020	Freezer Assembly
8	02-0929-01	Seal, Water
9	13-0704-00	Gasket
10	A29463-001	Adapter Freezer
11	02-2577-01	Adapter Large

FREEZER ASSEMBLY (C MODEL OR REPLACEMENT FREEZER)

ITEM NUMBER	PART NUMBER	DESCRIPTION
1	03-1405-42	Screw
2	03-1417-13	Lockwasher
3	A32571-020	Ice Breaker (Includes Bearing & Seal)
4	02-2853-01	Seal
5	13-0617-46	O-Ring
6	A31839-001	Auger
7	A32431-020	Freezer Assembly (Includes 9, 10, 11 & 12)
8	02-0929-01	Water Seal
9	03-1558-05	Snap Ring
10	A24156-002	Drip Pan
11	13-0704-00	Gasket
12	13-0709-02	Water Shed

HQD750 THE PARTS ILLUSTRATIONS AND PARTS LISTS

DRIVE MOTOR ASSEMBLY

ITEM NUMBER	PART NUMBER	DESCRIPTION
1	02-1606-00	Oil Seal
2	13-0709-02	Water Shed C Model Only
3	02-2853-01	Oil Seal - Faces Up
4	03-1251-01	Screw*
5	A31230-001	Gear Case Cover Assembly*
6	02-1681-00	Thrust Race
7	03-1363-00	Retaining Ring
8	02-2541-01	Shaft, Output
9	03-1630-01	Key
10	02-2745-01	Gear, Output
11	02-1604-00	Third Pinion Assembly, Second Gear
12	02-1679-00	Thrust Race
13	A32368-020	Bearing (Includes Items 12, 13, & 14)
14	02-1679-00	Thrust Race
15	A26103-001	"O" Ring
16	A31230-001	Gear Case Assembly Bottom*
17	03-1408-24	Washer
18	02-1603-00	Second Pinion Assembly, First Gear
19	03-1408-24	Washer
20	12-1741-29	Bearing Shaft GE
	12-1741-20	Bearing Shaft Emerson
21	A32425-001	Drive Motor
22	12-1741-28	Switch, Start
		(General Electric) #1
	12-1741-32	Start Switch
		(General Electric) #2
	12-2314-21	Centrifugal Switch P.S.C.
	12-1741-22	Switch, Start (Emerson)
23	A25835-001	Gearcase Oil (1) Pint
24	A32404-021	Gearmotor Assembly Complete
25	12-2314-22	Capacitor (For G.E. PSC Only)

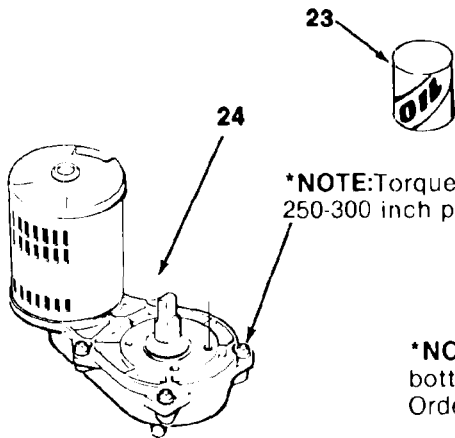
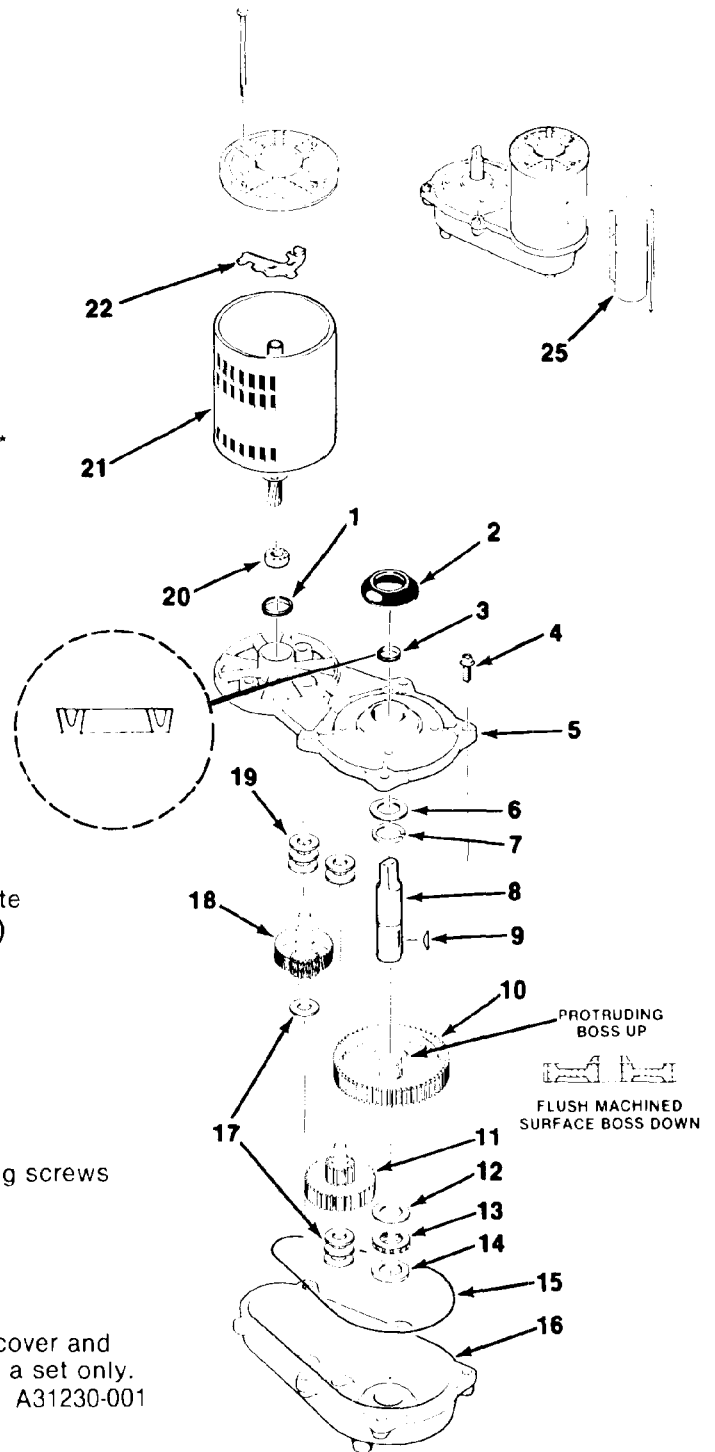

*NOTE: Torque cover mounting screws 250-300 inch pounds.

*NOTE: Gearcase cover and bottom are sold as a set only. Order Part Number A31230-001

HQD750 THE PARTS ILLUSTRATIONS AND PARTS LISTS

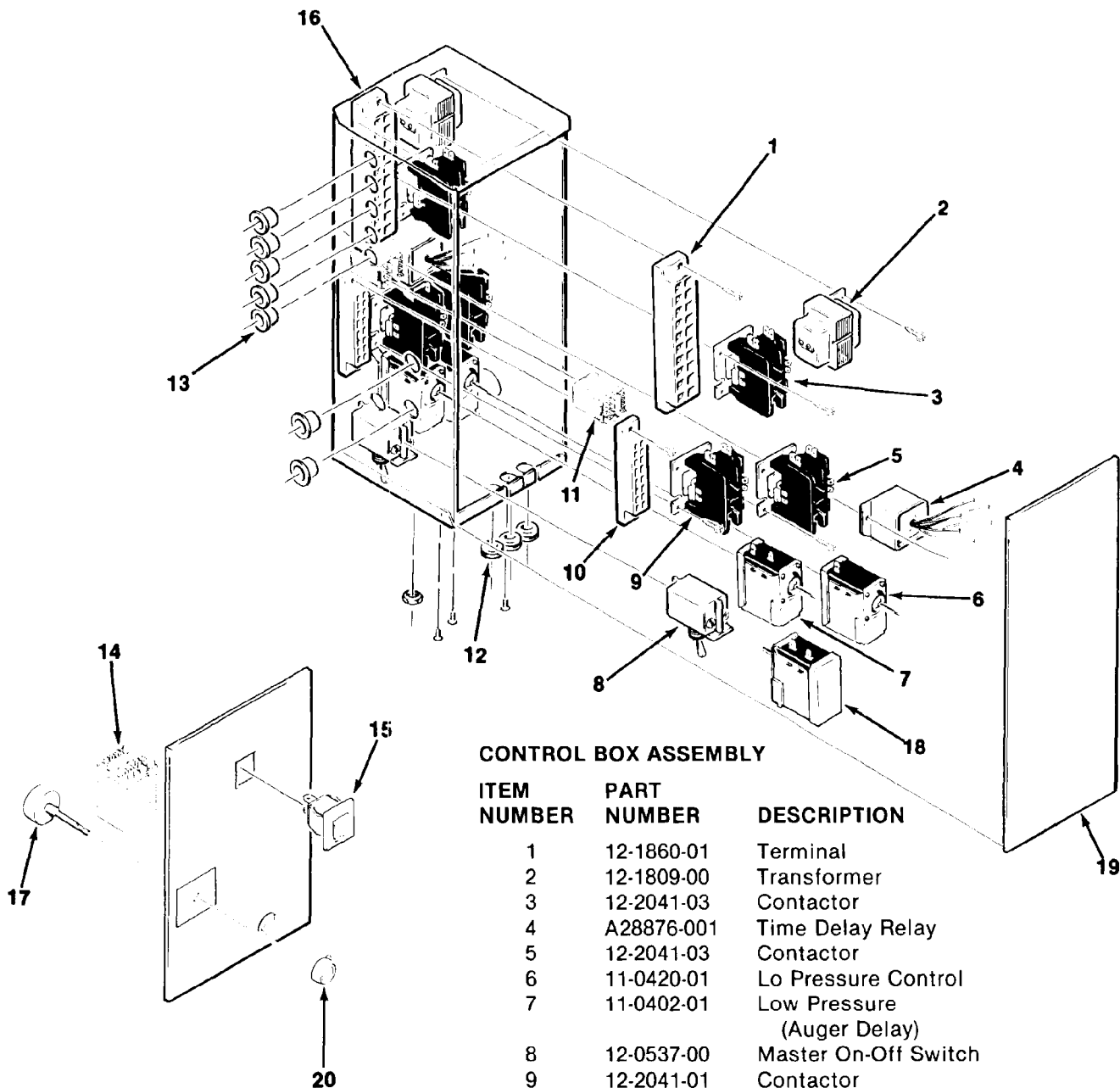

CONTROL BOX ASSEMBLY

ITEM NUMBER	PART NUMBER	DESCRIPTION
1	12-1860-01	Terminal
2	12-1809-00	Transformer
3	12-2041-03	Contactors
4	A28876-001	Time Delay Relay
5	12-2041-03	Contactors
6	11-0420-01	Lo Pressure Control
7	11-0402-01	Low Pressure (Auger Delay)
8	12-0537-00	Master On-Off Switch
9	12-2041-01	Contactors
10	12-1861-01	Terminal
11	12-2090-01	Relay
12	13-0557-00	Grommet
13	12-1213-10	Bushing
14	12-2090-02	Relay
15	12-2321-23	Start Switch
16	No Number	Control Box Fab Assembly
17	12-1557-00	Potentiometer
18	11-0357-04	Pressure Control (Water-Cooled Only)
19	A28874-001	Control Box Cover
20	02-1810-00	Potentiometer Knob

HQD750 WIRING DIAGRAMS

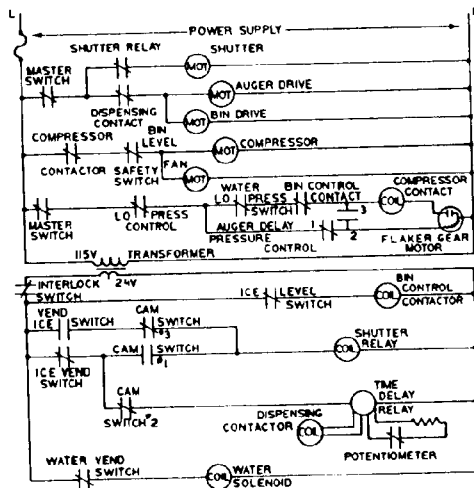
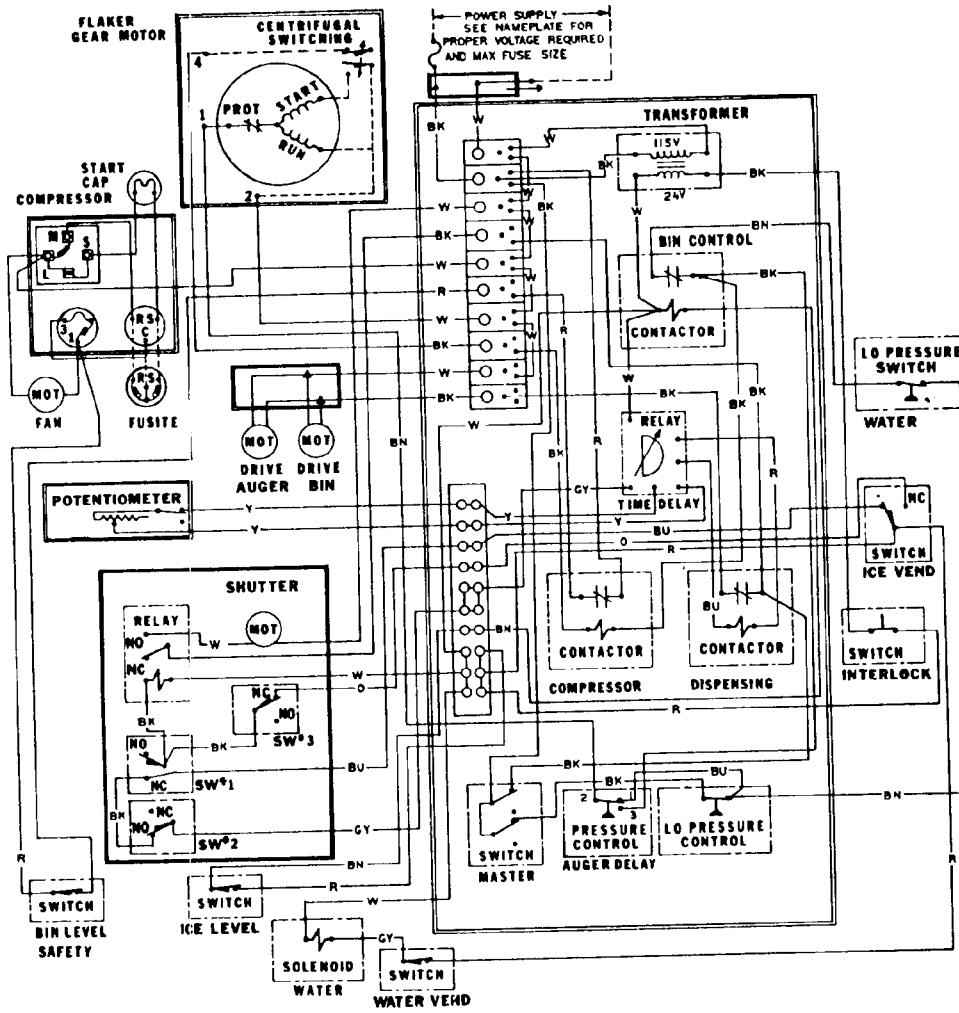

CONTROLS SHOW IN ICE MAKING MODE WITH BIN COMPARTMENT CLOSED AND ALL DISPENSING SYSTEMS IN OPERATION

THIS UNIT MUST BE GROUND

A29450-001

Wiring Diagram HQD750A (115/60/1) Air-Cooled
Up to S/N 611652-12E

HQD750 WIRING DIAGRAMS

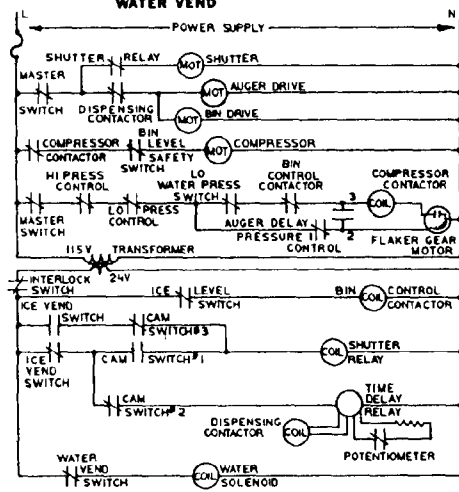
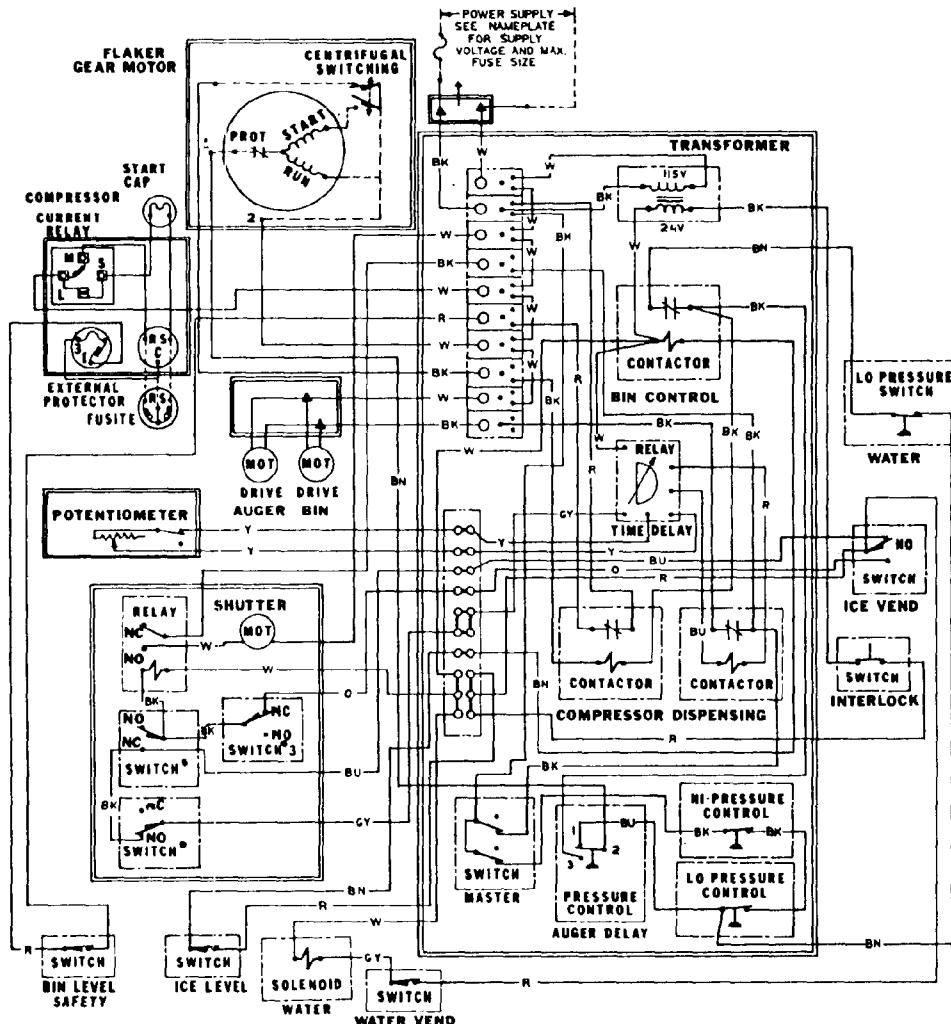

CONTROLS SHOWN IN ICE MAKING MODE WITH BIN COMPARTMENT CLOSED AND ALL DISPENSING SYSTEMS IN OPERATION

THIS UNIT MUST BE GROUNDED

A29448-001

Wiring Diagram HQD750A (115/60/1) Water-Cooled
Up to S/N 611652-12E

