

MC35 Parts List

Table of Contents

Cabinet

Air Cooled

Water Cooled

Evaporators

Freezing Chamber

Spray Bar Drive

Sump

Control Box

Wiring Diagrams

PARTS ILLUSTRATIONS AND PARTS LISTS

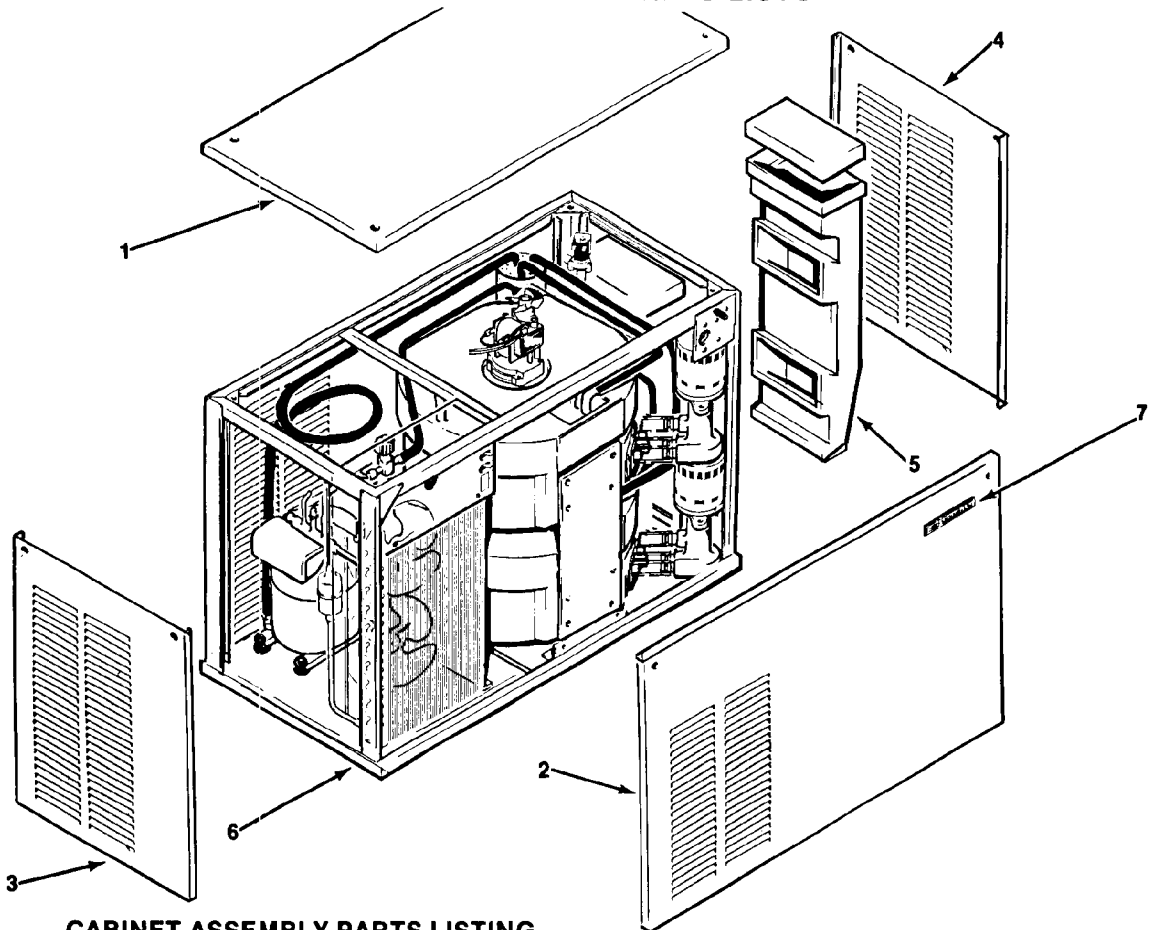

CABINET ASSEMBLY PARTS LISTING

ITEM NUMBER	PART NUMBER	DESCRIPTION	REQ'D NUMBER
1	A23784-007	Panel, Top - (Enamel) Sandalwood	1
	A23784-002	Panel, Top - (Stainless Steel)	1
2		Attaching Part, Index 1	
	03-1417-15	Lockwasher, No. 8 Countersunk External Tooth	2
	03-1419-09	Screw, No. 8 x 1-1/2 S/T Flat Hd	4
	A26183-005	Panel, Front - (Enamel) Sandalwood	1
3	A26183-002	Panel, Front - (Stainless Steel)	1
		Attaching Part, Index 2	
	03-1417-15	Lockwasher, No. 8 Countersunk External Tooth	2
	03-1419-09	Screw, No. 8 x 1-1/4 S/T Flat Hd (SS)	2
4	A23899-006	Panel, Left Side - (Enamel) Sandalwood	1
	A23899-002	Panel, Left Side - (Stainless Steel)	1
		Attaching Part, Index 3	
	03-1404-10	Screw, No. 8 x 1/2 T/F Tap (Stainless Steel)	2
5	A23900-006	Panel, Right Side - (Enamel) Sandalwood	1
	A23900-002	Panel, Right Side - (Stainless Steel)	2
		Attaching Part, Index 4	
	03-1404-10	Screw, No. 8 x 1/2 T/F Tap (Stainless Steel)	2
5	A27822-001	Chute, Cube - w/Cover	1
6	A26179-001	Frame Assembly	1
7	15-0156-00	Emblem Plate	1

PARTS ILLUSTRATIONS AND PARTS LISTS

MAJOR ASSEMBLIES AIR-COOLED PARTS LISTING

ITEM NUMBER	PART NUMBER	DESCRIPTION	REQ'D NUMBER
1	12-2263-21	Pump Assembly, Water	1
		Attaching Parts, Index 1	
	<i>No Number</i>	Holder, Drain Tube	1
	02-0706-00	Clamp, Worm Drive	1
	03-1407-05	Washer, No. 1/4 Plain	1
	03-0571-01	Screw, No. 1/4-20 x 1/2 T/C Hex Hd	1
2	18-0398-01	Air Cooled Condenser	1
		Attaching Parts, Index 2	
	03-1407-05	Washer, No. 1/4 Plain	2
	03-0571-00	Screw, No. 1/4-20 x 1/4 T/C Hex Hd	2
3	12-0675-25	Fan Blade	1
4	no number	Mount, Fan Motor	2
5	18-3704-02	Fan Motor, 230/60/1	1
	18-3704-07	Fan Motor, 208/60/1	1
		Attaching Parts, Index 3	
	03-1417-03	Lockwasher, No. 8 External Tooth	4
	<i>No Number</i>	Screw, No. 8-32 x 1-1/4 Phil Recess Pan Hd	4
6	18-3800-07	Compressor, 208/60/1	
	18-3800-02	Compressor, 230/60/1	
	18-3800-03	Compressor, 208-230/60/3	
	Not Illustrated: Compressor Overload:		
	18-2300-32	208/60/1	
	18-2300-25	230/60/1	
	18-2300-31	208-230/60/3	
7	02-2426-02	Drier	1
8	<i>No Number</i>	Control Box Cover	1
9	<i>No Number</i>	Control Box Assembly	1
		(See Page 31)	
		Attaching Part, Index 7	
	03-1417-15	Lockwasher, No. 8 Countersunk External Tooth	2
	03-1419-09	Screw, No. 8 x 1-1/4 S/T Flat Hd	
		(Stainless Steel) (used to attach LEFT end)	2
	03-1404-08	Screw, No. 8 x 3/8 T/F Tap (used to attach	
		RIGHT end)	2
10	12-2135-01	Valve, Solenoid - Hot Gas	1
11	12-1434-01	Inlet Assembly, Water	1
12	11-0345-02	Control, Cube Size	1
13	11-0353-03	Control, Bin Level	1
		Attaching Parts, Index 10 & 11	
	03-1403-14	Screw, No. 8-32 x 3/16 Phil Recess Pan Hd	4
14	A29835-020	Exchanger Assembly, Heat	1
15	02-2038-01	Curtain Assembly	2
		Attaching Part, Index 13	
	03-1526-01	Clip, U-Type	6
16	<i>No Number</i>	Freezer Assembly, Dual (See Page 25)	1
		Attaching Parts, Index 14	
	02-0571-00	Screw, No. 1/4-20 x 1/2 T/C Hex Hd	4
17	A26230-001	Flow Control, .30 gpm Air-Cooled	2
18	16-0723-01	Water Inlet Fitting	1
19	A23929-001	Condenser Shroud	1
20	13-1394-01	Pal Nut	1

PARTS ILLUSTRATIONS AND PARTS LISTS

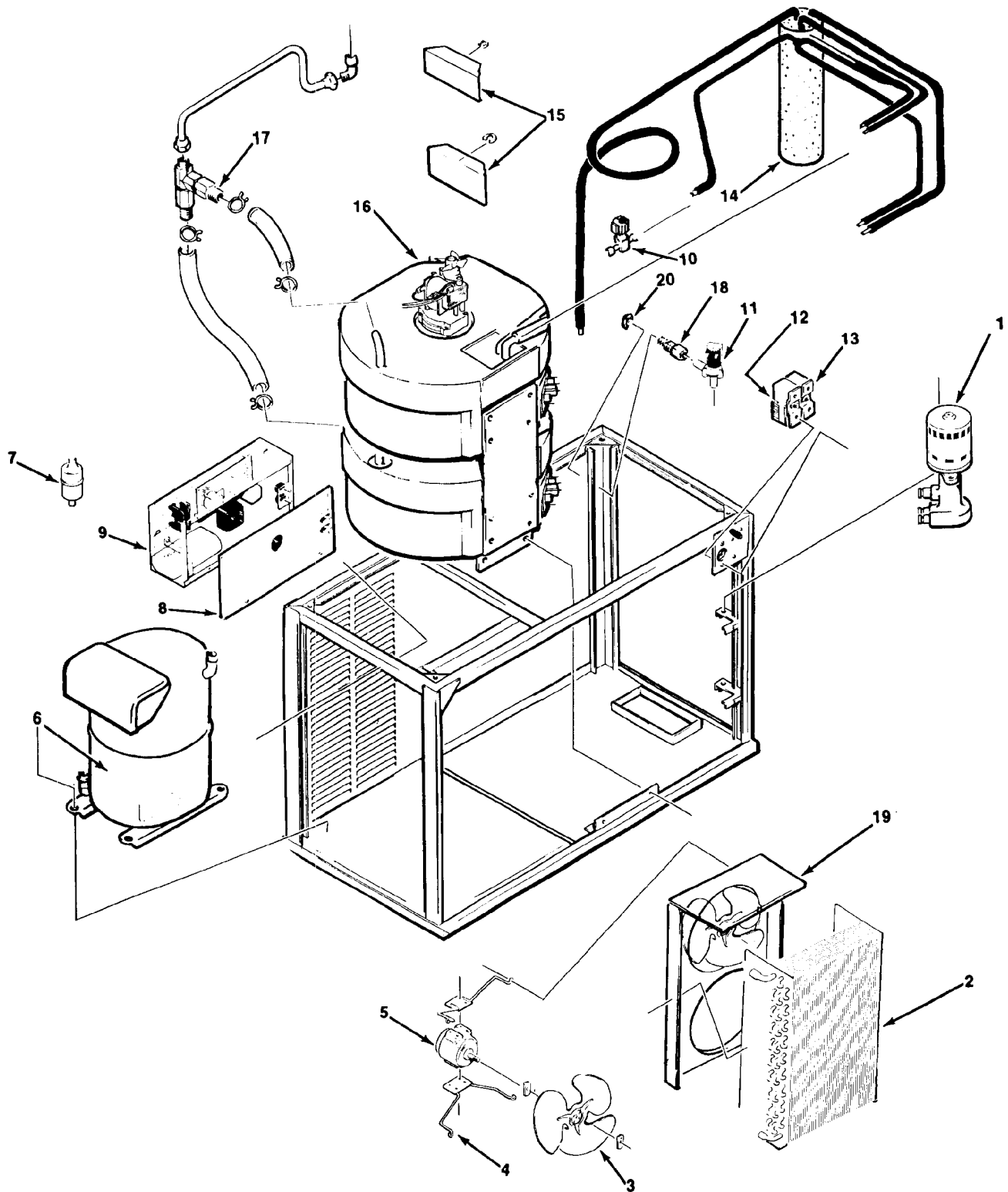

PARTS ILLUSTRATIONS AND PARTS LISTS

MAJOR ASSEMBLIES WATER-COOLED PARTS LISTING

ITEM NUMBER	PART NUMBER	DESCRIPTION	REQ'D NUMBER
1	12-2263-21	Pump Assembly, Water	1
		Attaching Parts, Index 1	
	<i>No Number</i>	Holder, Drain Tube	2
	02-0706-00	Clamp, Worm Drive	2
	03-1407-05	Washer, No. 1/4 Plain	2
	03-1571-01	Screw, No. 1/4-20 x 1/2 T/C Hex Hd	2
2	18-3306-02	Condenser, Water-Cooled	1
		Attaching Parts, Index 2	
	03-1407-05	Washer, No. 1/4 Plain	2
	03-0571-00	Screw, No. 1/4-20 x 1/4 T/C Hex Hd	2
3	16-0401-00	Elbow, 3/8 NPT x 3/8 Flare Brass	1
4	11-0198-02	Valve, Water Regulator	1
5	A15924-000	Bracket, Mounting - w/nipple	1
6	18-3800-07	Compressor, 208/60/1	
	18-3800-02	Compressor, 230/60/1	
	18-3800-03	Compressor, 208-230/60/3	
	Not Illustrated: Compressor Overload:		
	18-2300-32	208/60/1	
	18-2300-25	230/60/1	
	18-2300-31	208-230/60/3	
7	02-2426-02	Drier	1
		Attaching Part, Index 5	
	<i>No Number</i>	Tie, Cable	1
8	<i>No Number</i>	Cover, Control Box	1
		Attaching Part, Index 6 to 7	
	03-1404-04	Screw, No. 6 x 1/4 T/F Tap (Stainless Steel)	2
9	<i>No Number</i>	Control Box Assembly (See Page 31)	1
		Attaching Part, Index 7	
	03-1417-15	Lockwasher, No. 8 Countersunk External Tooth	2
	03-1419-09	Screw, No. 8 x 1-1/4 S/T Flat Hd (Stainless Steel) (Used to attach LEFT end)	2
	03-1404-08	Screw, No. 8 x 3/8 T/F Tap (Used to attach RIGHT end)	2
10	12-2135-01	Valve, Solenoid - Hot Gas	1
11	12-1434-01	Inlet Assembly, Water	1
12	11-0345-02	Control, Cube Size	1
13	11-0353-03	Control, Bin Level	1
		Attaching Parts, Index 10 & 11	
	03-1403-14	Screw, No. 8-32 x 3/16 Phil Recess Pan Hd	4
14	A29835-020	Exchanger Assembly, Heat	1
15	02-2038-01	Curtain Assembly	2
		Attaching Part, Index 13	
	03-1526-01	Clip, U-Type	6
16	<i>No Number</i>	Freezer Assembly - Dual (See Page 25)	1
		Attaching Parts, Index 14	
	02-0571-00	Screw, No. 1/4-20 x 1/2 T/C Hex Hd	4
17	A26230-002	Flow Control, .50 gpm	2
18	16-0723-01	Water Inlet Fitting	1
19	13-1394-01	Pal Nut	1

PARTS ILLUSTRATIONS AND PARTS LISTS

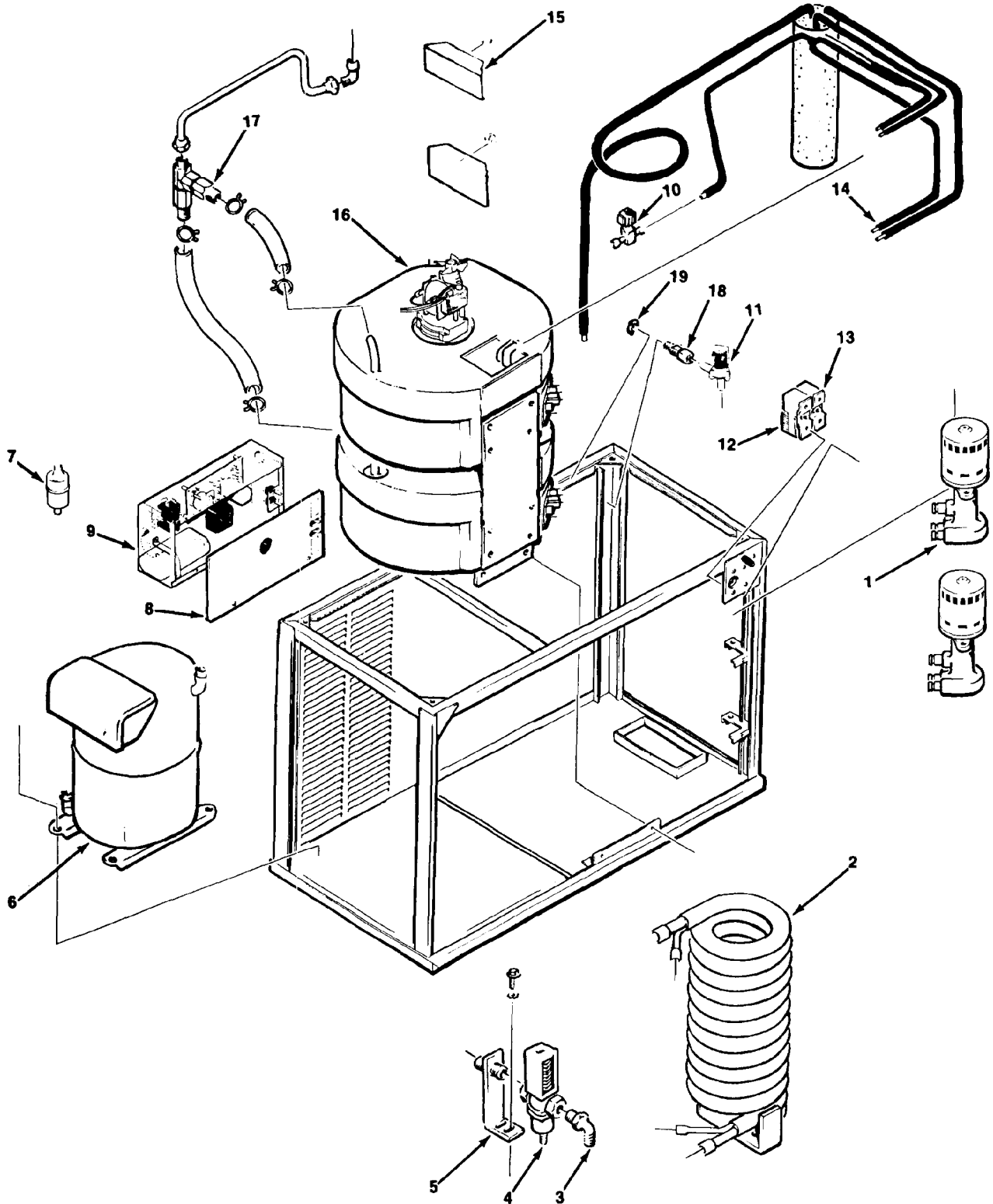

PARTS ILLUSTRATIONS AND PARTS LISTS

FREEZER ASSEMBLY - DUAL

ITEM NUMBER	PART NUMBER	DESCRIPTION	REQ'D NUMBER
1	02-2369-02	Fork, Drive - Upper (left-hand thread)	1
2	12-0675-25	Blade, Fan - Drivemotor	1
3	A24656-001	Drivemotor Assembly, Agitator	1
4	13-0176-00	Gasket - Agitator Drivemotor Assembly	1
		Attaching Parts, Index 3 & 4	
	03-1404-28	Screw, No. 6 x 1 T/F Tap	4
5	02-2369-01	Fork, Drive - Lower (left-hand thread)	1
6	A24502-001	Plate, Mount Upper	1
7	A24500-001	Plate, Mount Lower	1
		Attaching Parts, Index 6 & 7	
	03-1417-05	Lockwasher, No. 10 External Tooth	2
	03-1404-18	Screw, No. 10 x 5/8 T/F Tap	2
		(used in two upper holes in Index 6)	
	03-1417-05	Lockwasher, No. 10 External Tooth	2
	03-1360-00	Screw, No. 10-16 x 1/2 S/T	2
		(used in middle holes in Index 6)	
	03-0571-00	Screw, No. 1/4-20 x 1/2 T/C Hex Hd	3
		(used to attach Index 6 to 7)	
	03-1417-05	Lockwasher, No. 10 External Tooth	2
	03-1404-18	Screw, No. 10 x 5/8 T/F Tap	2
		(used in middle two holes in Index 7)	
	03-1417-05	Lockwasher, No. 10 External Tooth	2
	03-1360-00	Screw, No. 10-16 x 1/2 S/T	2
		(used in lower two holes in Index 7)	
8	<i>No Number</i>	Chamber, Freezing - Upper	1
9	<i>No Number</i>	Chamber, Freezing - Lower	1
		(See Page 30)	

PARTS ILLUSTRATIONS AND PARTS LISTS

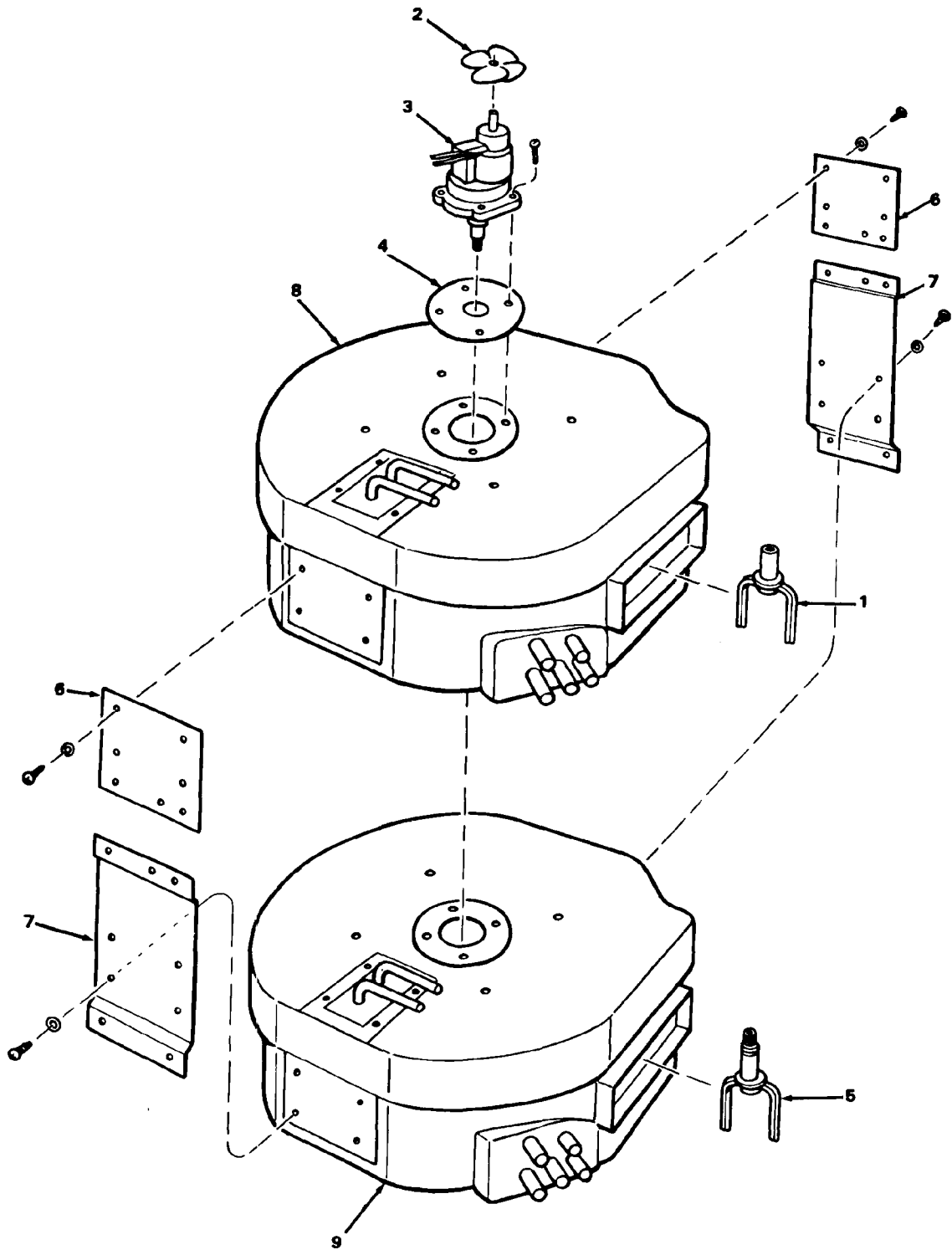

PARTS ILLUSTRATIONS AND PARTS LISTS

FREEZING CHAMBER ASSEMBLY

ITEM NUMBER	PART NUMBER	DESCRIPTION	REQ'D NUMBER
1	02-2129-01	Spacer, Tube Attaching Part, Index 1	2
	02-2065-02	Plug, Hole	8
2	02-2124-01	Cover, Insulation	2
3	02-2123-01	Cover, Freezing Chamber	2
4	A27218-002	Platen Assembly, Cup (SMALL ice cube cups)	4
	A27217-002	Platen Assembly, Cup (MEDIUM ice cube cups) Attaching Parts, Index 2, 3, 4	4
	A24830-001	Washer, Centering	8
	03-1404-10	Screw, No. 8 x 1/2 T/F Tap	8
5	A25480-001	Bar Assembly, Spray	4
6	13-0617-25	O-Ring	4
7	<i>No Number</i>	Bushing/Bearing (Left-hand threads)	2
7a	A27687-001	Bushing, Nut (Used in UPPER Chamber)	2
7b	02-2120-01	Bearing, Spray Bar (Used in LOWER Chamber) (Also order P/N 13-0168-00 Water Seal with Index 7a or 7b)	2
8	02-2028-01	Bottom, Inner	2
9	13-0674-07	Tube, Tygon (8-inch lg.) (Order by the foot) Attaching Part, Index 9	2
	02-1358-01	Clamp, Hose	4
10	<i>No Number</i>	Sump, Freezing Chamber (See Pg. 30)	2
		NOTE: Spray Deflectors below, are ONLY used on SMALL ice cube Cup Platen Assembly P/N A27218-002.	
X1	A24198-001	Deflector, Spray (Installed at rounded ends, over top of cup molds)	4
X2	A24198-003	Deflector, Spray (Installed around hole in Platen, with notch as shown)	2
X3	A24198-004	Deflector, Spray (Installed LAST, under two tubes and over ends of X2)	2

PARTS ILLUSTRATIONS AND PARTS LISTS

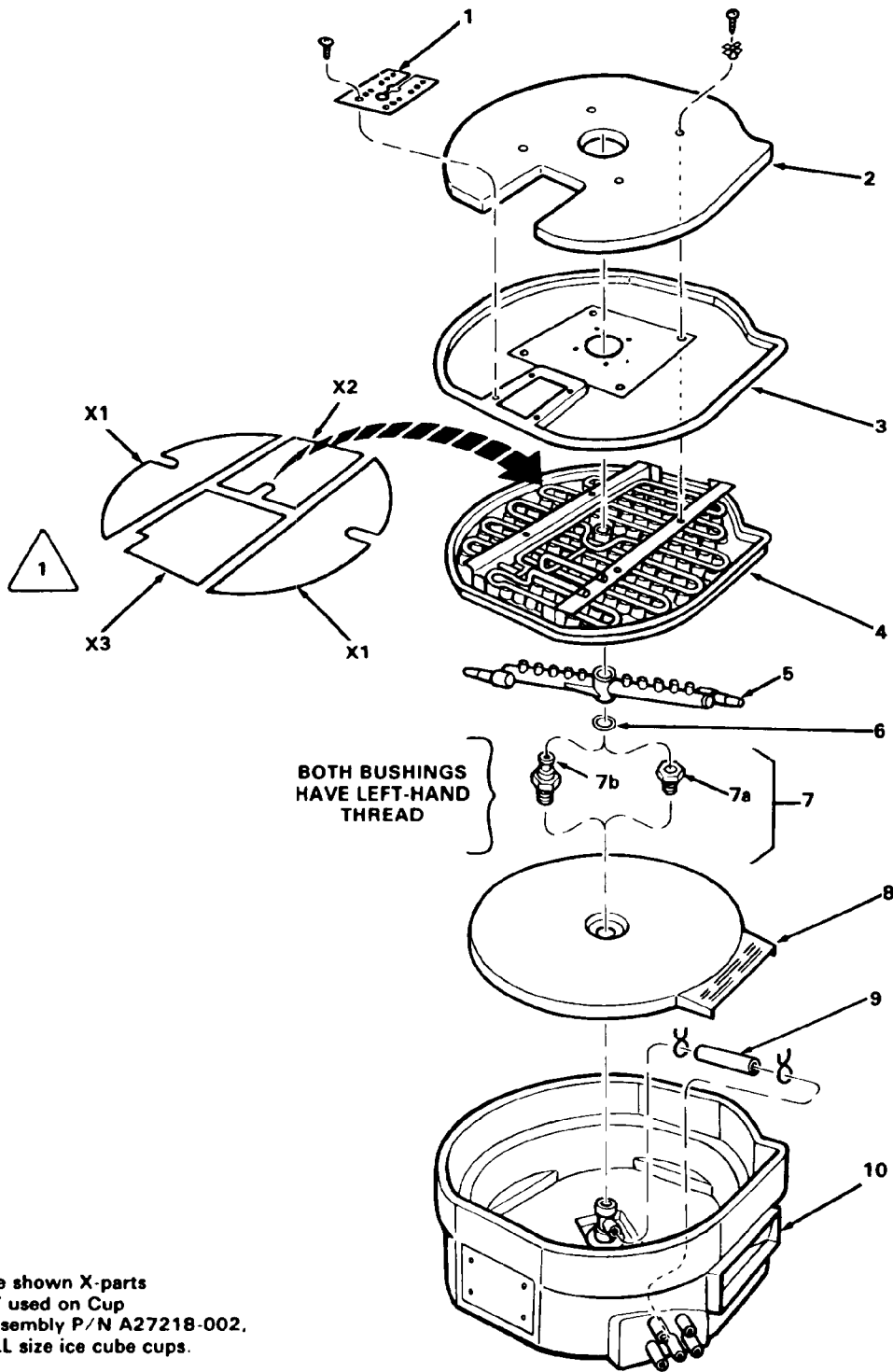

The above shown X-parts are ONLY used on Cup Platen Assembly P/N A27218-002, for SMALL size ice cube cups.

PARTS ILLUSTRATIONS AND PARTS LISTS

DUAL DRIVE SPRAY ASSEMBLIES

ITEM NUMBER	PART NUMBER	DESCRIPTION	REQ'D NUMBER
1	02-2369-02	Fork, Drive - Upper (Left-hand thread)	Ref.
2	12-0675-25	Blade, Fan - Drivemotor	Ref.
3	A24656-001	Drivemotor Assembly, Agitator	Ref.
4	13-0176-00	Gasket - Agitator Drivemotor Assembly	Ref.
		Attaching Parts, Index 3 & 4	
	03-1404-28	Screw, No. 6 x 1 T/F Tap	Ref.
5	02-2369-01	Fork, Drive - Lower (Left-hand thread)	Ref.
6	A25480-001	Bar Assembly, Spray (w/rubber tips)	2
7	13-0653-00	Rubber - Spray Bar	4
8	13-0617-25	O-Ring	2
9	<i>No Number</i>	Tube Assembly, Water	1
9a	02-2271-01	Support, Spray Bar	1
9b	<i>No Number</i>	Tube, Water (Available only in Index X, Water Tube Assembly, Kit P/N A29868-001. Obsolete, order Index X.	1
10	13-0168-00	Seal, Water	2
11	A29687-001	Bushing, Nut (Also order Index 10, Water Seal)	1
12	02-2120-01	Bearing, Spray Bar	1
13	13-0675-07	Tube, Tygon (8-inch lg.) (Order by the foot)	2
		Attaching Parts, Index 13	
	02-1358-01	Clamp, Hose	4
14	02-2121-02	Housing, Inlet	2
15	A23827-001	Plate, Support - Spray Bar	2
16	03-1409-11	Washer, Non-Metallic - (7/8-inch I.D.)	2
17	02-2122-01	Plug, Bottom	1
		(Used on Lower Freezing Chamber)	
18	A29687-002	Bushing, Nut (Also order Index 10, Water Seal) (Used in Upper Freezing Chamber)	1
X	A29868-001	Kit - Water Tube Assembly	1
X1	02-2369-01	Fork, Drive (Left-hand thread)	1
X2	13-0168-00	Seal, Water	2
X3	A29687-001	Bushing, Nut (Left-hand thread)	1
X4	A29687-002	Bushing, Nut (Left-hand thread)	1
X5	<i>No Number</i>	Tube, Water (Order Kit P/N A29868-001)	1
X6	02-2271-01	Support, Spray Bar	1

PARTS ILLUSTRATIONS AND PARTS LISTS

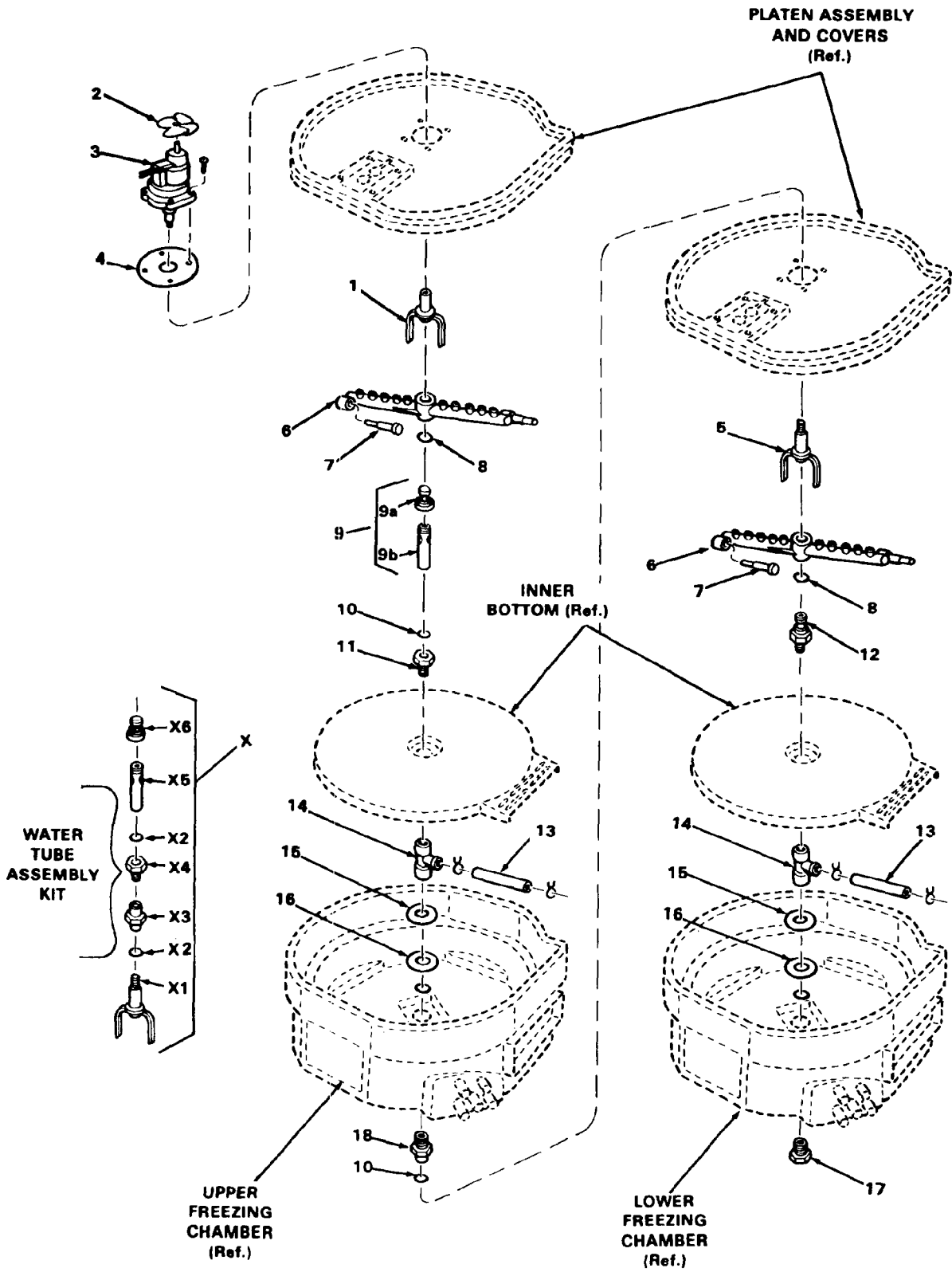

PARTS ILLUSTRATIONS AND PARTS LISTS

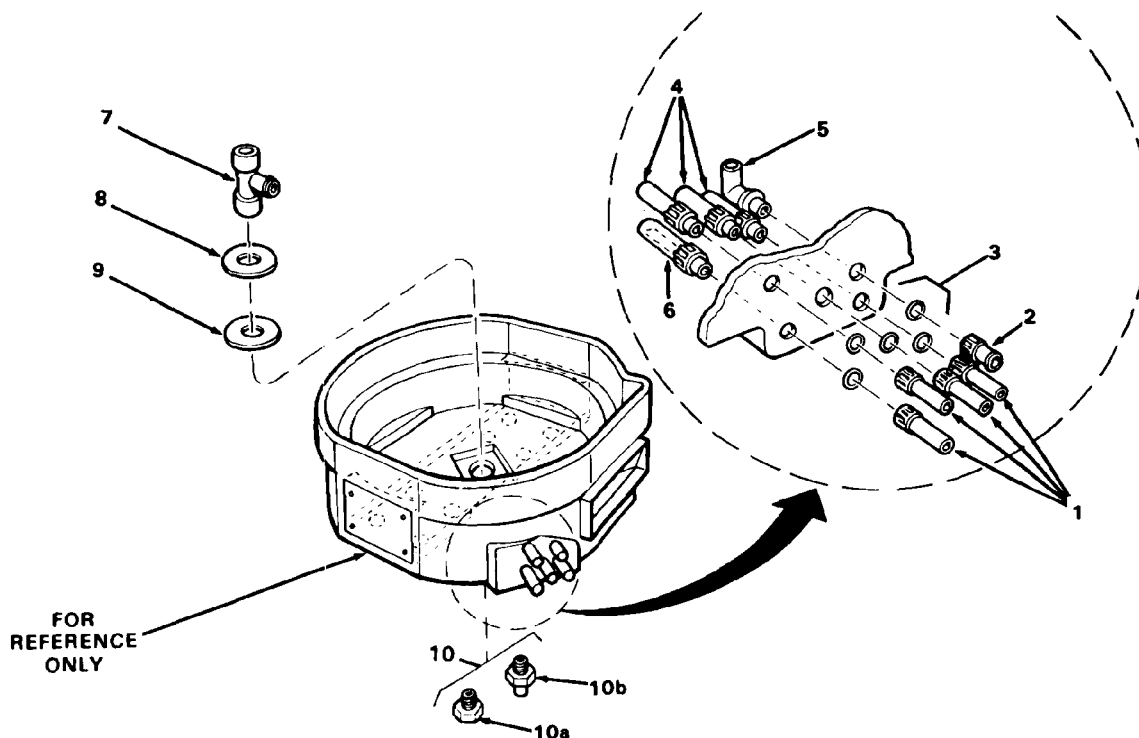

FREEZING CHAMBER — SUMP W/TUBES

ITEM NUMBER	PART NUMBER	DESCRIPTION	REQ'D NUMBER
NOTE: P/N A24819-001 shipped as replacement for both upper and lower Freezing Chamber, with Index 10a installed. For upper Freezing Chamber, also order Index 10b.			
1	02-2081-01	Tube, Female	4
2	A24379-001	Tube, Female - (Cut off)	1
3	13-0617-02	O-Ring	5
4	02-2080-01	Tube, Male	3
5	02-2125-01	Pipe, Stand	1
6	02-2082-01	Tube, Pick-Up - Pump	1
7	02-2121-01	Housing, Inlet	1
8	A23827-001	Plate, Support - Spray Bar	1
9	03-1409-11	Washer, Non-Metallic - 7/8-inch I.D.	1
10	<i>No Number</i>	Plug, Bottom	1
10a	02-2122-01	Plug, Bottom (Used in Lower Freezing Chamber)	Ref.
10b	A27197-002	Plug, Bottom (Used in Upper Freezing Chamber)	Ref.

MC35 CONTROL BOX

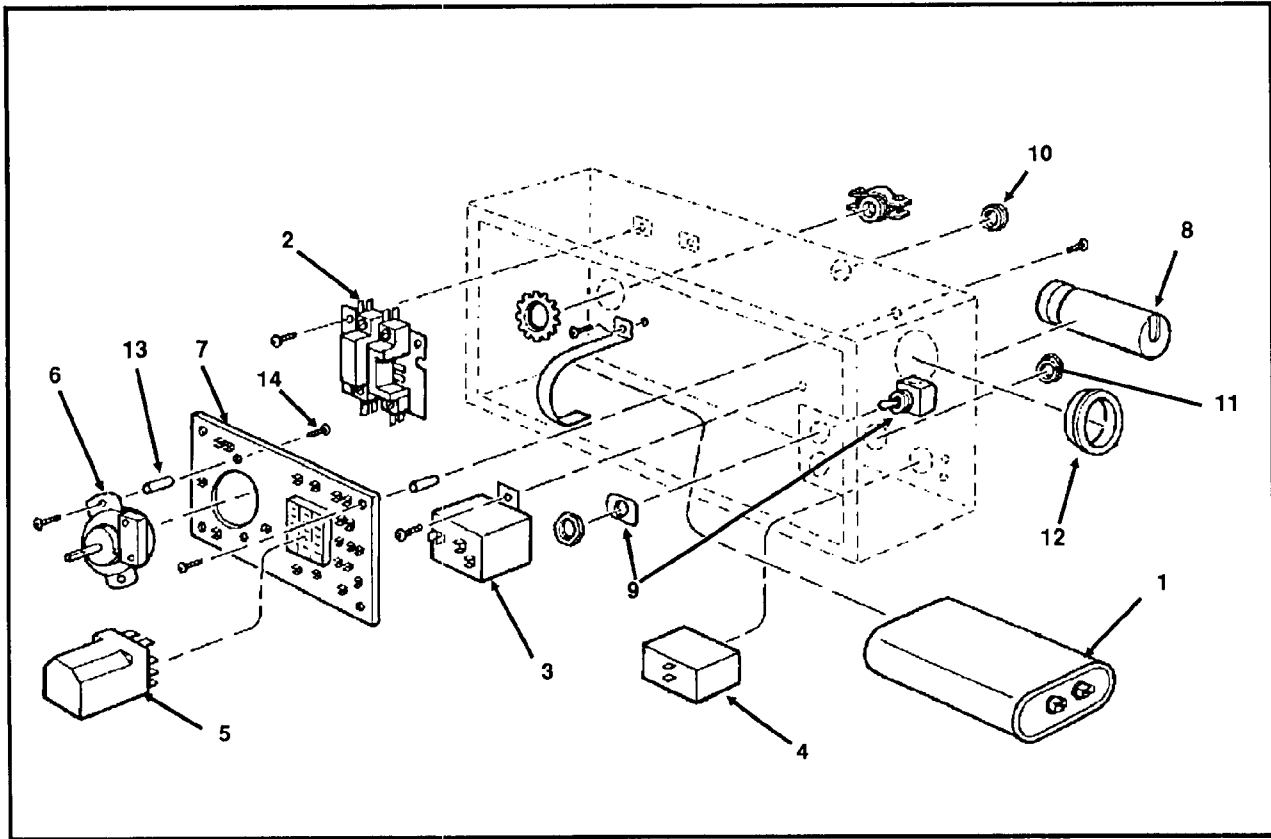

ITEM NUMBER	PART NUMBER	DESCRIPTION
1.	18-1902-29	Run Capacitor, 230/60/1
	18-1902-34	Run Capacitor, 208/60/1
2.	12-2048-02	Contactor, single phase
	12-0739-01	Contactor, three phase
3.	18-1903-29	Potential relay, 230/60/1
	18-1903-34	Potential relay, 208/60/1
4.	11-0388-02	High pressure control (Water Cooled Only)
5.	12-1879-02	Relay
6.	12-1979-01	Timer & Switch
7.	12-1912-01	Circuit Board
8.	18-1901-15	Start Capacitor
9.	12-0426-01	Toggle Switch
10.	12-1213-04	Snap bushing, 1/2"
11.	12-1213-10	Snap bushing, 7/8"
12.	12-1213-13	Snap bushing, 1 1/2"
13.	02-2242-01	7/8" stand off
14.	03-1403-40	Screw

WIRING DIAGRAM 230-115/60/1 Water Cooled

CAUTION: MORE THAN ONE DISCONNECT MEANS MAY BE REQUIRED TO DISCONNECT ALL POWER TO THIS UNIT.

THIS UNIT MUST BE GROUNDED

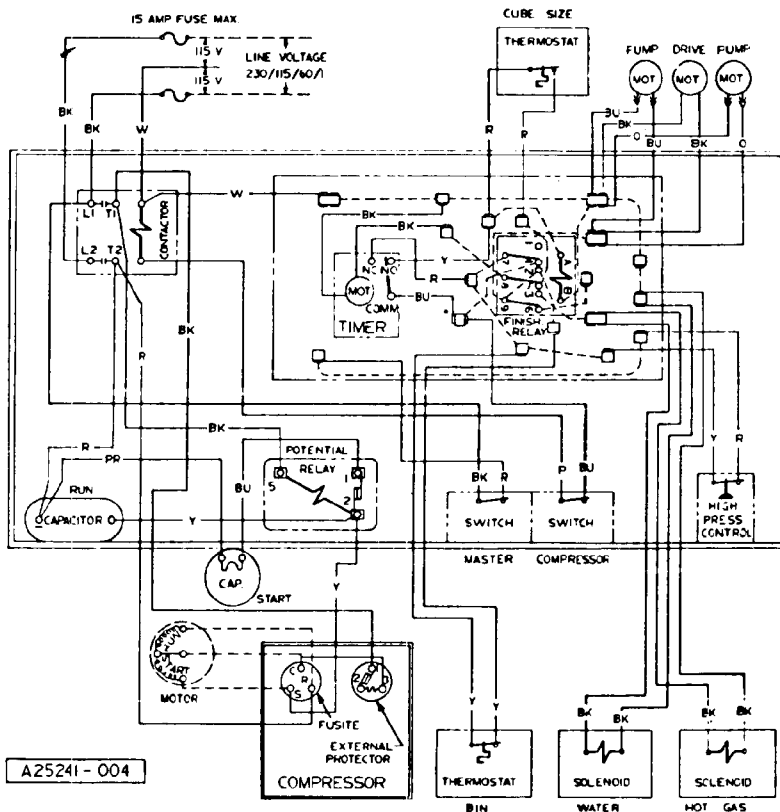

THIS UNIT SHOWN IN THE TIMED PORTION OF THE FREEZING CYCLE

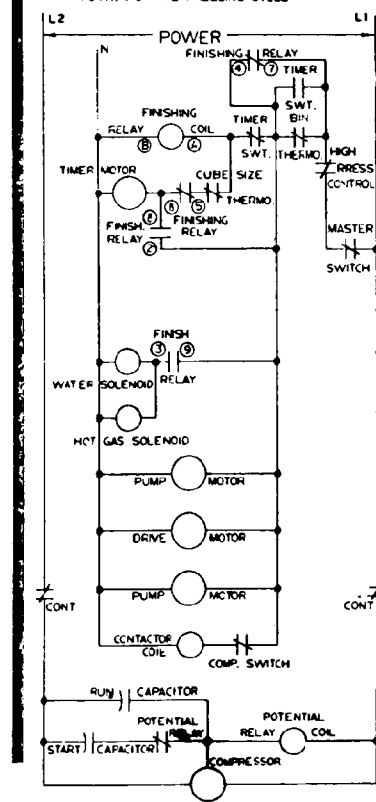

WIRING DIAGRAM 208/60/1 Air Cooled

CAUTION: MORE THAN ONE DISCONNECT MEANS MAY BE REQUIRED TO DISCONNECT ALL POWER TO THIS UNIT.

THIS UNIT MUST BE GROUNDING

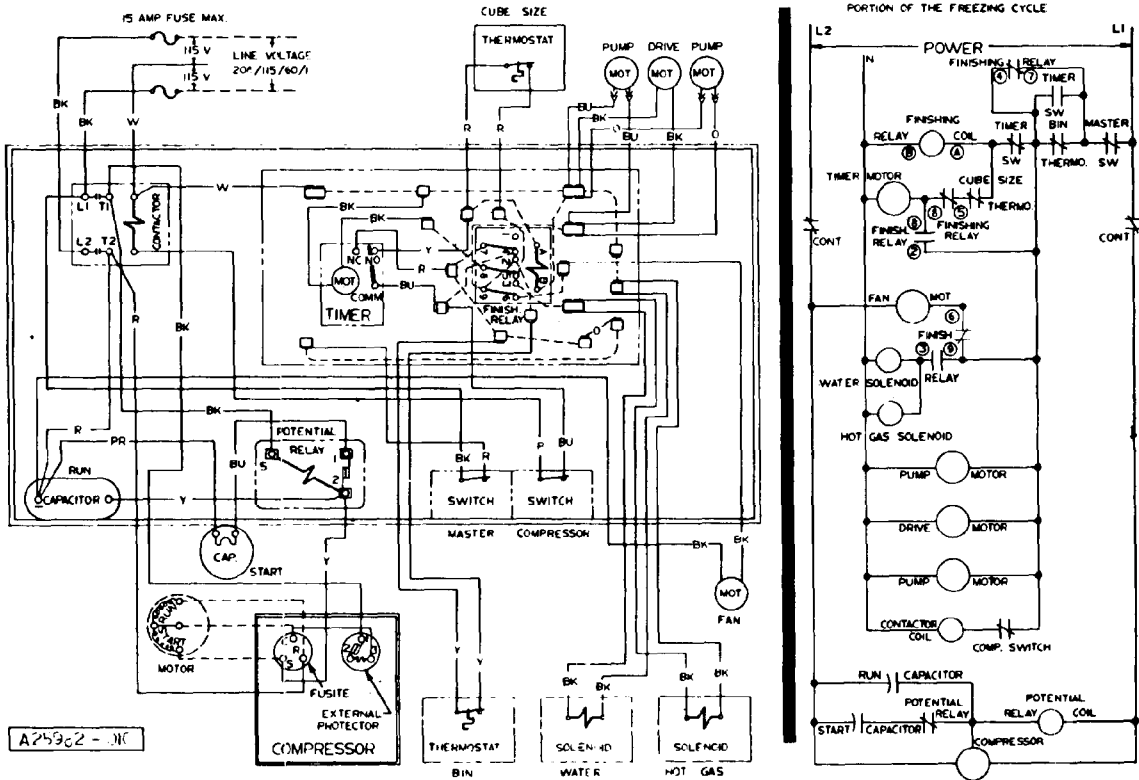

WIRING DIAGRAM 208/60/1 Water Cooled

CAUTION: MORE THAN ONE DISCONNECT MEANS MAY BE REQUIRED TO DISCONNECT ALL POWER TO THIS UNIT.

THIS UNIT MUST BE GROUNDED

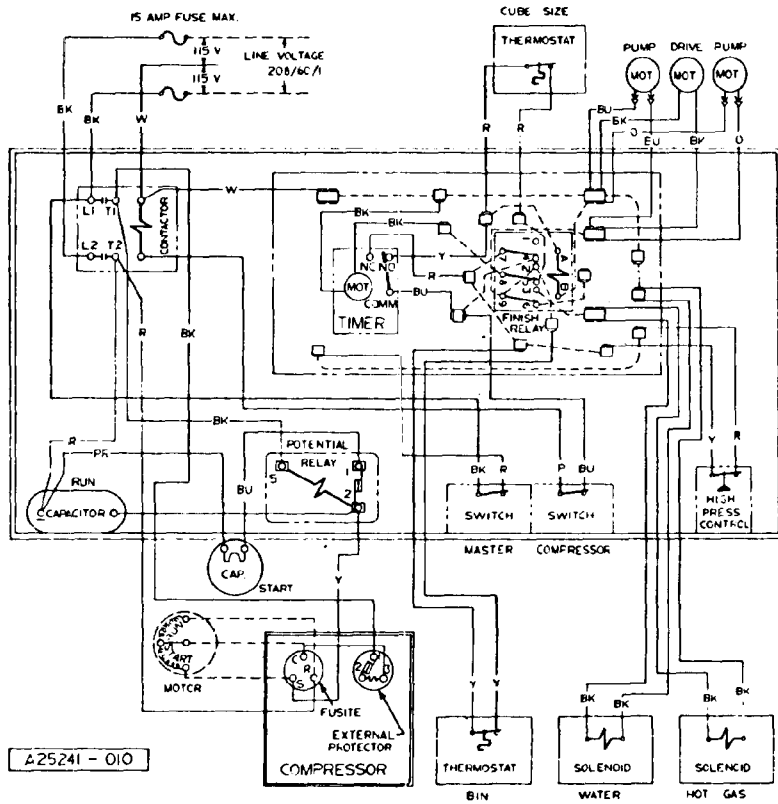

THIS UNIT SHOWN IN THE TIMED PORTION OF THE FREEZING CYCLE

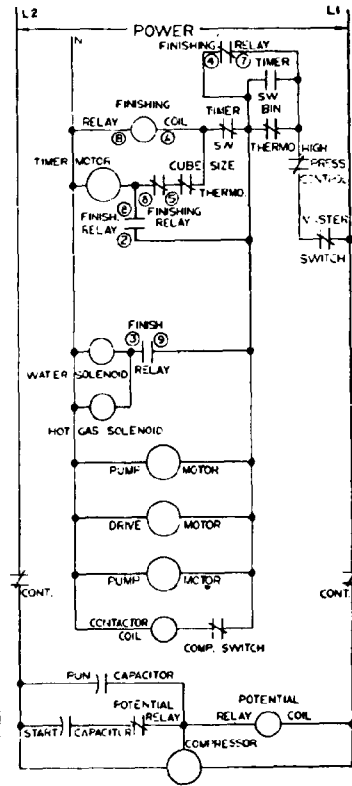

WIRING DIAGRAM 208-220/60/30 Water Cooled

CAUTION: MORE THAN ONE DISCONNECT MEANS MAY BE REQUIRED TO DISCONNECT ALL POWER TO THIS UNIT.

THIS UNIT MUST BE GROUNDED

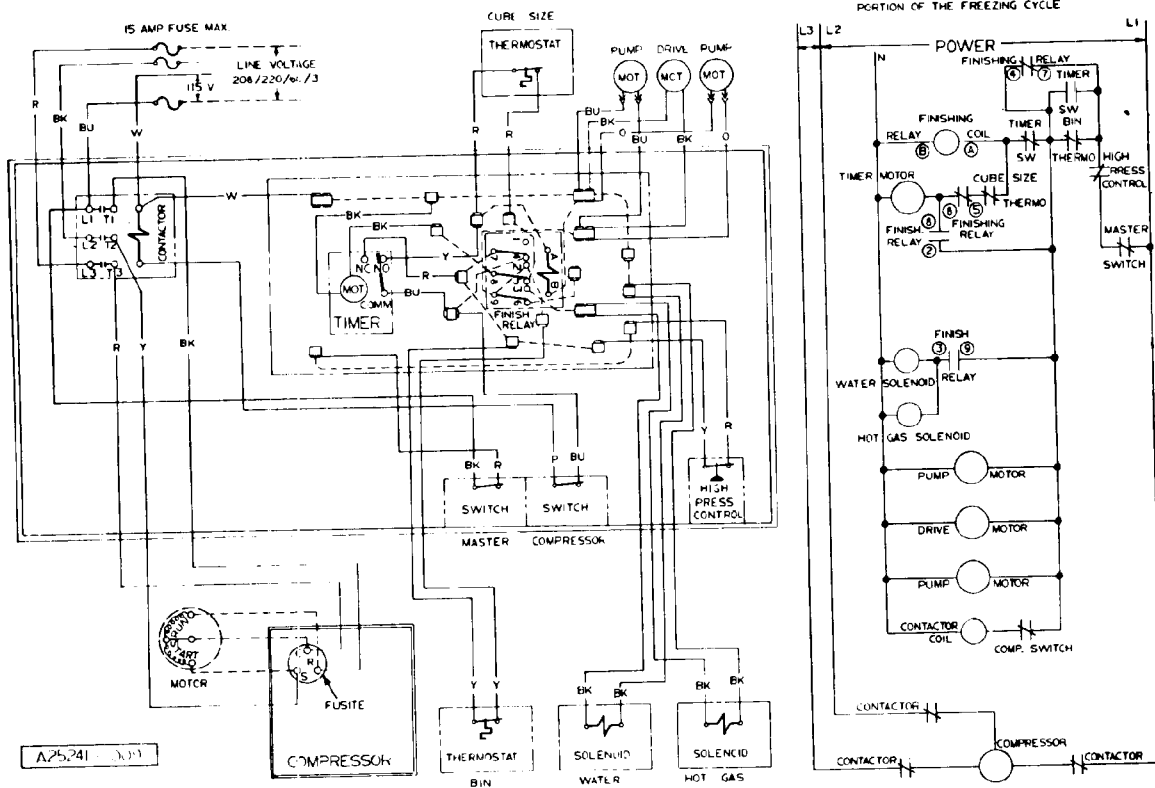

**WIRING DIAGRAM
208-220/60/3
Air Cooled**

CAUTION: MORE THAN ONE DISCONNECT MEANS MAY BE REQUIRED TO DISCONNECT ALL POWER TO THIS UNIT.

THIS UNIT MUST BE GROUNDED

