

MCD200 Parts List

Table of Contents

Cabinet

Air Cooled Parts

Water Cooled Parts

Evaporator

Freezing Chamber

Agitator Motor

Water Pump

Drive Motor

Bin Assembly

Storage Area

Compressor

Control Box

Wiring Diagrams

MCD200C

PARTS ILLUSTRATIONS AND PARTS LISTS

CABINET ASSEMBLY

ITEM NUMBER	PART NUMBER	DESCRIPTION
1	A27616-001	Panel, Right Side
	A27616-002	Panel, Right Side S.S.
2		Attaching Parts, Index #1
	03-1417-15	Lockwasher #8 (6)
	03-1419-25	Screw #8x1 (6)
	A27619-001	Panel, Front Assembly
3	A27619-002	Panel, Front Assembly S.S.
		Attaching Parts, Index #2
	03-1409-09	Screw (2)
4	02-2399-01	Grill
5	A27908-000	Sink Foam Assembly
		Attaching Parts, Index #4
	03-1593-01	Catch Stud (2)
	03-1592-01	Catch Receptacle (2)
	A30378-001	Splash Panel
6		Attaching Parts, Index #5
	03-1593-01	Catch Stud (4)
	03-1592-01	Catch Receptacle (4)
	A27617-001	Panel, Left Side
7	A27617-002	Panel, Left Side S.S.
		Attaching Parts, Index #6
	03-1417-15	Lockwasher, #8 (6)
	03-1419-25	Screw, #8x1 (6)
	A27618-001	Panel, Back
	A27618-002	Panel, Back S.S.
8		Attaching Parts, Index #7
	03-1417-15	Lockwasher, #8 (6)
	03-1419-25	Screw, #8x1 (6)
	A27633-001	Panel, Top (Lid Assembly)
	A27633-002	Panel, Top (Lid Assembly) S.S.
9		Attaching Parts, Index #8
	03-1403-55	Screw, 1/4-20 x 2-1/2 (4)
10	A27608-001	Drain Tube Nut
	A27605-001	Drain Tube

MCD200C

PARTS ILLUSTRATIONS AND PARTS LISTS

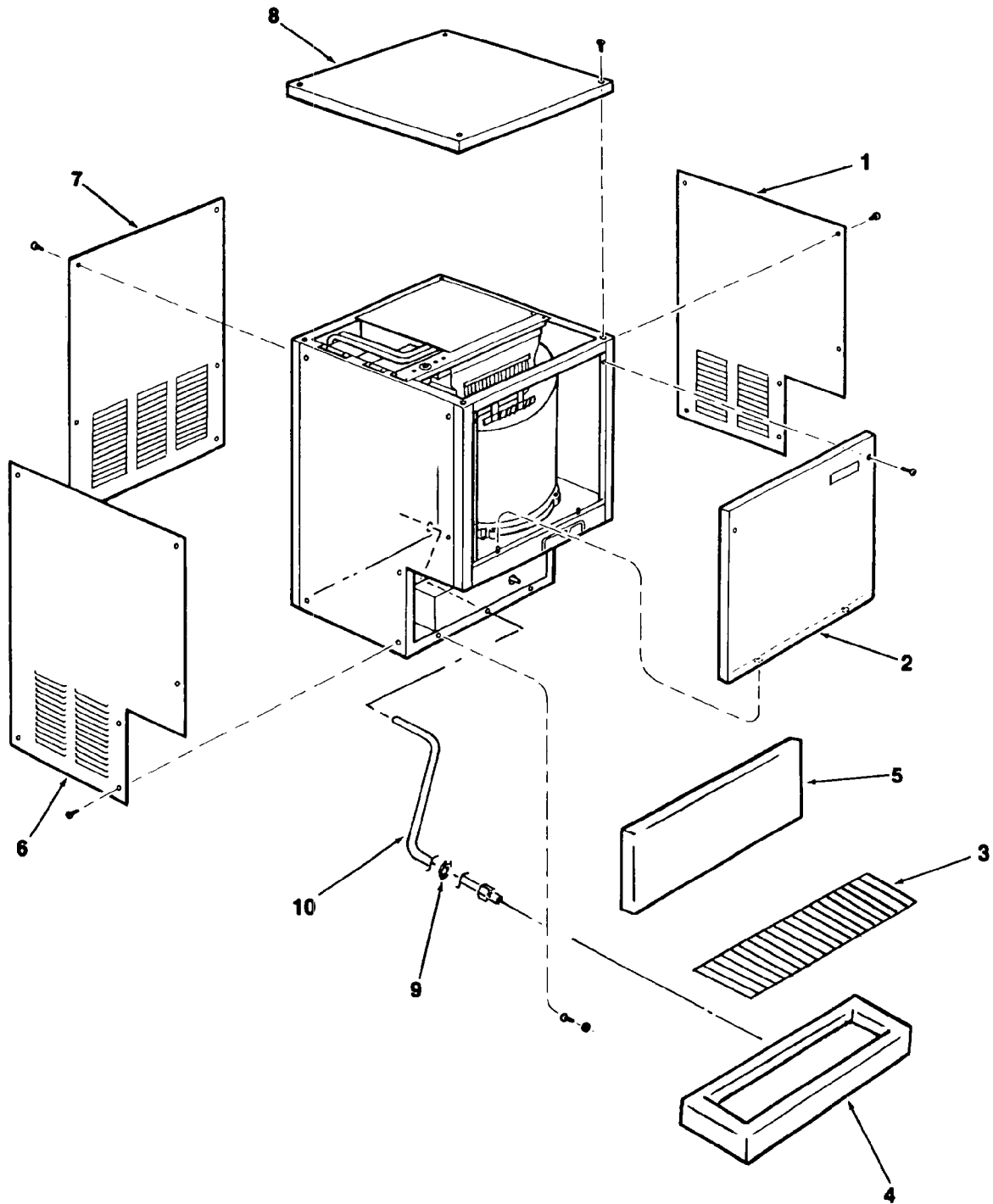

MCD200C

PARTS ILLUSTRATIONS AND PARTS LISTS

AIR-COOLED ASSEMBLY

ITEM NUMBER	PART NUMBER	DESCRIPTION
1	02-2555-01	Shroud
		Attaching Parts, Index #1 and #2
	03-1407-01	Washer
2	03-1404-05	Screw, #6x3/8
	18-3726-01	Air-Cooled Condenser
		Attaching Parts, Index #2
3	03-1410-03	Lockwasher, #1/4 Helical Spring (2)
	03-1405-03	Screw, #1/4-20 x 1/2 Hex Cap (2)
	18-0625-00	Fan Blade
		Attaching Parts, Index #3 and #4
4	<i>No Number</i>	Vibration Pad
	<i>No Number</i>	Fan Mounting Nut
	12-1681-01	Fan Motor
		Attaching Parts, Index #4 and #5
5	<i>No Number</i>	Screw, #8-36 (4)
	18-0422-00	Fan Mounting Bracket
		Attaching Parts, Index #5
6	03-1405-03	Screw (4)
	03-1410-03	Washer (4)
	A09388-001	Drier Brace
7	02-0831-00	Drier
		Attaching Parts, Index #6 and #7
	03-1403-67	Screw, #8-32 x 3/8 Phil Recess Pan Head
8	12-2008-01	Coil & Frame Assembly - Hot Gas Valve
9	12-2009-01	Coil Clamp - Hot Gas Valve
		Attaching Parts
	03-1403-15	Screw, No. 8-32x1/4 Phil Recess Pan Head
10	12-2007-01	Valve Body & Plunger Assembly - Hot Gas Valve
11	A27850-020	Exchanger Assembly, Heat
12	03-1405-20	Bolt, No. 1/4-20x5/8 Hex
13	03-1417-12	Washer, No. 5/16 External Tooth
14	03-1407-07	Washer, No. 5/16 Plain
15	18-2200-28	Grommet
16	18-2200-27	Sleeve, Mounting
17	A27522-001	Base Assembly

MCD200C

PARTS ILLUSTRATIONS AND PARTS LISTS

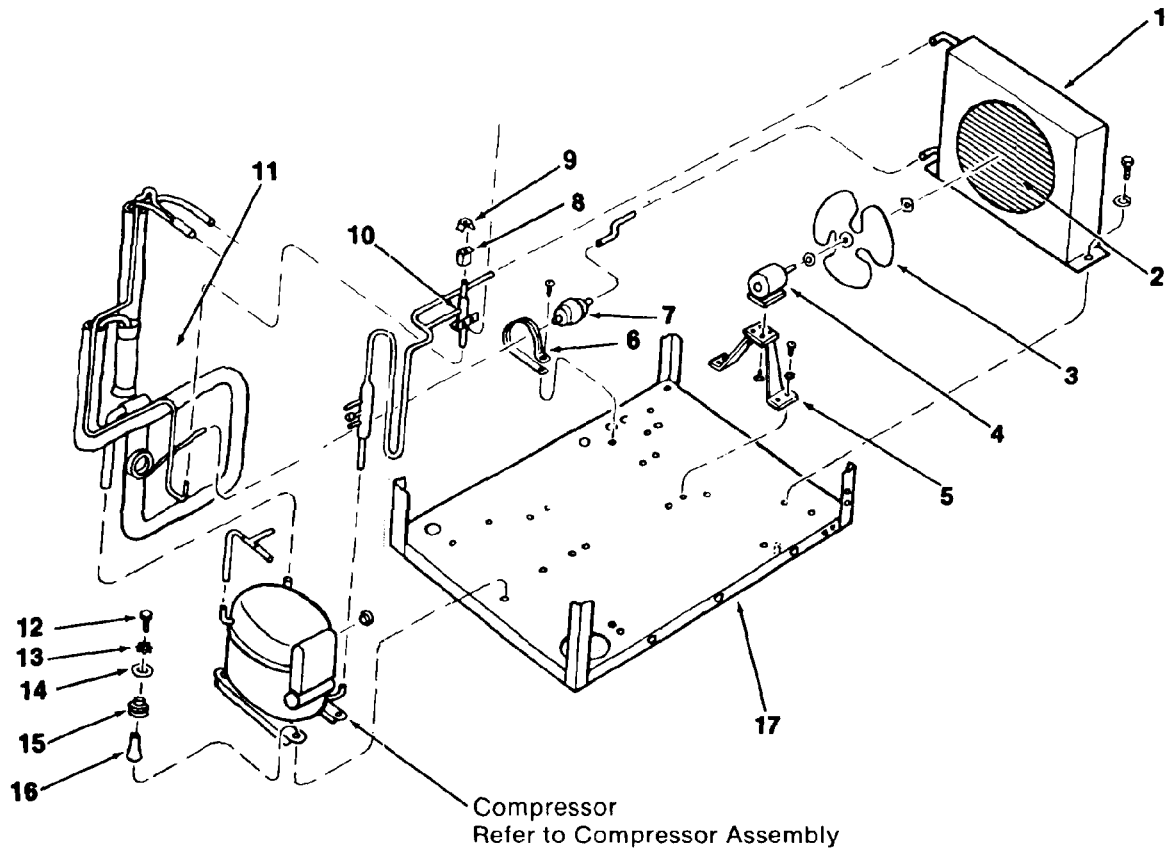

MCD200C

PARTS ILLUSTRATIONS AND PARTS LISTS

WATER-COOLED ASSEMBLY

ITEM NUMBER	PART NUMBER	DESCRIPTION
1	18-3707-01	Condenser, Water-Cooled Attaching Parts, Index #1
	03-1410-03	Lockwasher, #1/4 Helical Spring
2	03-1405-03	Screw, #1/4-20 x 1/2 Hex Cap
	11-0198-02	Regulator, Water Attaching Parts
	03-1410-03	Lockwasher, #1/4 Helical Spring
2a	03-1405-03	Screw, #1/4-20 x 1/2 Hex Cap
	16-0677-01	Coupling
2b	A15924-000	Nipple Assembly, Pipe (w/bracket)
2c	16-0401-00	Elbow, 3/8 NPT x 3/8 Flare Brass
3	A09388-001	Brace, Drier Attaching Parts, Index #3
	03-1403-67	Screw, #8-32 x 3/4 Phil Recess Pan Head
	02-0831-00	Drier
4	12-2008-01	Coil & Frame Assembly - Hot Gas Valve
6	12-2009-01	Coil Clamp - Hot Gas Valve Attaching Parts
	03-1403-15	Screw, No. 8-32x1/4 Phil Recess Pan Head
	12-2007-01	Valve Body & Plunger Assembly - Hot Gas Valve
8	A27850-020	Exchanger Assembly, Heat
9	03-1405-20	Bolt, No. 1/4-20x5/8 Hex
10	03-1417-12	Washer, No. 5/16 External Tooth
11	03-1407-07	Washer, No. 5/16 Plain
12	18-2200-28	Grommet
13	18-2200-27	Sleeve, Mounting

MCD200C

PARTS ILLUSTRATIONS AND PARTS LISTS

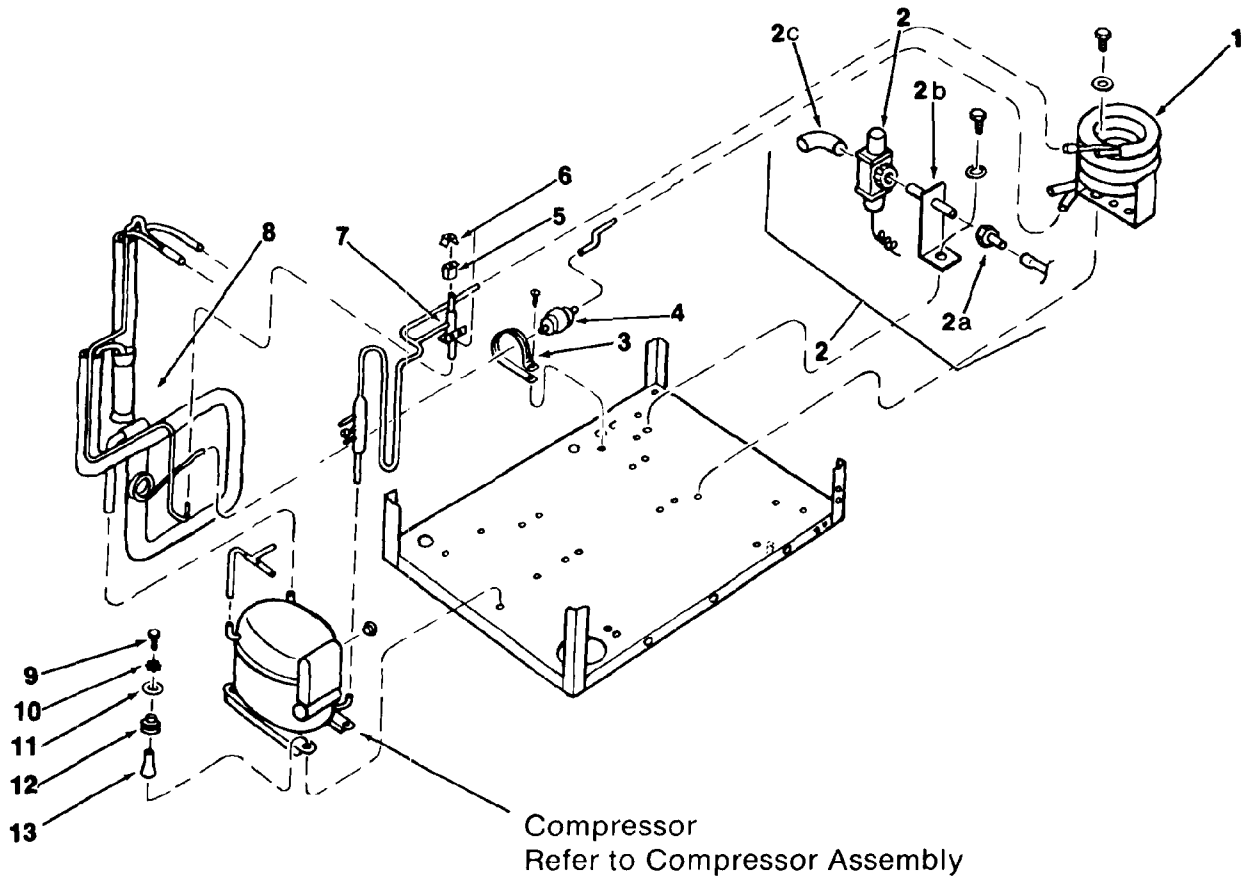

MCD200C

PARTS ILLUSTRATIONS AND PARTS LISTS

EVAPORATOR ASSEMBLY

ITEM NUMBER	PART NUMBER	DESCRIPTION	ITEM NUMBER	PART NUMBER	DESCRIPTION
1	No Number	Sheet, Styrene			
2	No Number	Tube Assembly			
3	A23163-003	Linkage Assembly			
3a	02-1965-03	End Linkage			
3b	03-1406-15	Nut			
3c	A27790-001	Arm, Linkage (Agitator Drive)	17	No Number	Enclosure & Bracket Assembly, Water Pump, see pg 13
3d	A27789-001	Arm, Linkage (Spray Bar Drive)			Attaching Parts
	03-0431-05	Setscrew		03-1613-01	Screw, #6 x 1/2 T/F Tap
4	02-2484-01	Clip, Tube	18	No Number	Strap, Bonding
		Attaching Parts			Attaching Parts
	03-1613-01	Screw, #6 x 1/2 T/F Tap		03-1404-04	Screw, #6 x 14 T/F Tap
5	No Number	Chamber Assembly, Freezing, see pg 11	19	No Number	Channel
		Attaching Parts		03-1531-04	Screw, #6 x 3/8 T/F Tap
	03-1613-01	Screw, #6 x 1/2 T/F Tap	20	No Number	Bushing, Anti-Short
6	A28855-001	Curtain Assembly	21	No Number	Cover, Channel
7	A26916-001	Chute, Cube (Left)			Attaching Parts
	A26923-001	Chute, Cube (Right)		03-1531-04	Screw, #6 x 3/8 T/F Tap
8	A28191-001	Retainer	22	12-1213-06	Bushing, Snap
		Attaching Parts	23	A27850-020	Exchanger Assembly, Heat
	03-0255-00	Wingnut	24	A28946-020	Platen Assembly
9	A28133-001	Holder Assembly, Cube Chute Bulb	25	11-0354-02	End of Cube Size Control
10	No Number	Cover, Temperature Control			Capillary Tube
		Attaching Parts	26	13-0674-06	Tube, Tygon (20-inch)
	03-1404-10	Screw, #8 x 1/2 T/F Tap			(Order by the foot)
11	11-0353-02	Control, Temperature (Bin Thermostat)	27	No Number	Drain Assembly
		Attaching Parts			Attaching Parts
	03-1605-01	Clip, Bulb Holder		02-1338-00	Clamp, Hose
	03-1403-15	Screw, #8 - 32 x 1/4	28	No Number	Line Assembly, Water
		Phil Recess Pan Head			Attaching Parts
12	No Number	Support, Gasket		03-1394-01	Nut, Pal
		Attaching Parts	29	13-0674-04	Tube, Tygon (15-1/2 inch)
	03-1613-01	Screw, #6 x 1/2 T/F Tap			(Order by the foot) Attaching Parts
13	11-0354-02	Control Temperature (Cube Size Control)		02-1535-00	Clamp, Hose (at Valve)
		Attaching Parts		02-1912-03	Clamp, Worm Drive (at Water Inlet Tube)
14	No Number	Strap, Bonding	30	12-1900-10	Valve, Inlet
		Attaching Parts	31	No Number	Fitting, Inlet Water
	03-1404-04	Screw, #6 x 1/4 T/F Tap			Attaching Part
15	No Number	Cover, Channel		03-1394-01	Nut, Pal
		Attaching Parts	32	A25805-001	Bracket, Mounting
	03-1531-04	Screw, #6 x 3/8 T/F Tap			Attaching Parts
16	No Number	Drive Assembly, Agitator, see pg 12		03-1410-03	Lockwasher, No. 1/4-20x1/2 Hex Cap
		Attaching Parts		03-1405-03	Screw, No. 1/4-20x1/2 Hex Cap
	03-1613-01	Screw, #6 x 1/2 T/F Tap	33	No Number	Conduit
			34	No Number	Clamp, Conduit
					Attaching Part
				03-0571-00	Screw, No. 1/4-20x1/2 T/C Hex Head
			35	No Number	Bushing, Anti-Short
			36	A27522-001	Base Assembly

MCD200C PARTS ILLUSTRATIONS AND PARTS LISTS

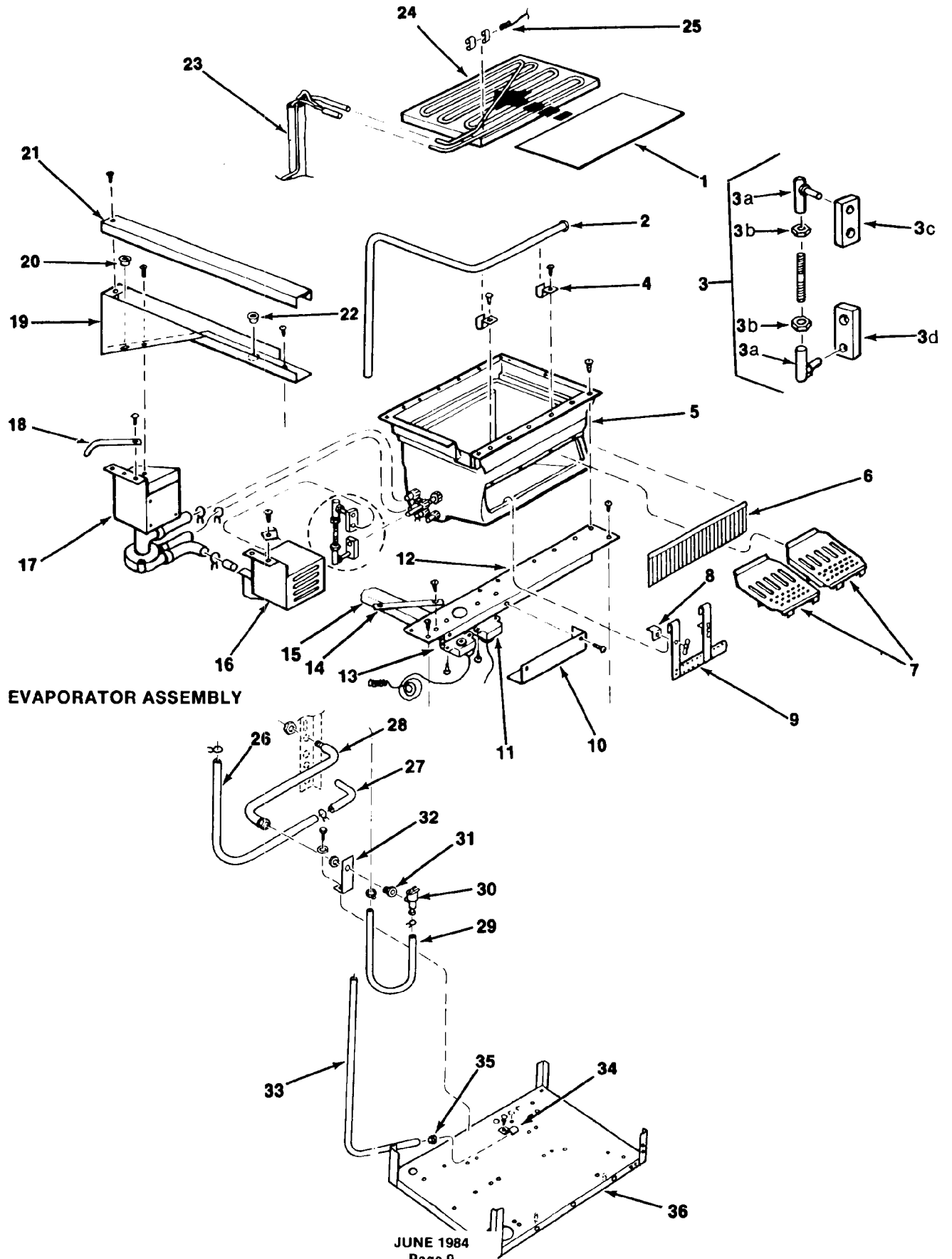

MCD200C

PARTS ILLUSTRATIONS AND PARTS LISTS

FREEZING CHAMBER ASSEMBLY

ITEM NUMBER	PART NUMBER	DESCRIPTION
1	A28853-001	Water Defector Assembly (2)
	03-1403-19	Attaching Parts, Index #1, #4, and #6 Screw, #8-32 x 1/2 Phil Recess Pan Head (2)
2	02-2419-01	Spray Bar End
3	13-0617-42	O-Ring
4	A28856-001	Curtain Rod Bracket, R.H.
5	A28855-001	Curtain Assembly
6	A28856-002	Curtain Rod Bracket, L.H.
7	02-2421-01	Freezing Chamber
8	A26901-001	Retaining Clip
9	A27787-001	Spray Bar Assembly
10	02-2125-01	Stand Pipe
11	02-2080-01	Male Tube (2)
12	13-0617-02	O-Ring (2)
13	02-2606-01	Female Tube, (2)
14	13-0796-01	Rubber Cap
		Attaching Part, Index #14
	02-1530-01	Hose Clamp
15	13-0617-02	O-Ring (2)
16	02-2606-01	Female Tube (2)
17	<i>No Number</i>	Drive Shaft Housing Assembly
18	02-2418-01	Drive Housing Assembly (Includes items 19 through 23)
19	<i>No Number</i>	Nut, Hex
20	13-0819-01	Water Seal (U-cup)
21	<i>No Number</i>	Housing Body
22	13-0819-01	Water Seal (U-cup)
23	<i>No Number</i>	Housing End
24	02-2452-01	Drive Journal
25	13-0617-30	O-Ring
26	02-2082-01	Tube, Pump Pick Up
27	02-2080-01	Tube, Male

MCD200C PARTS ILLUSTRATIONS AND PARTS LISTS

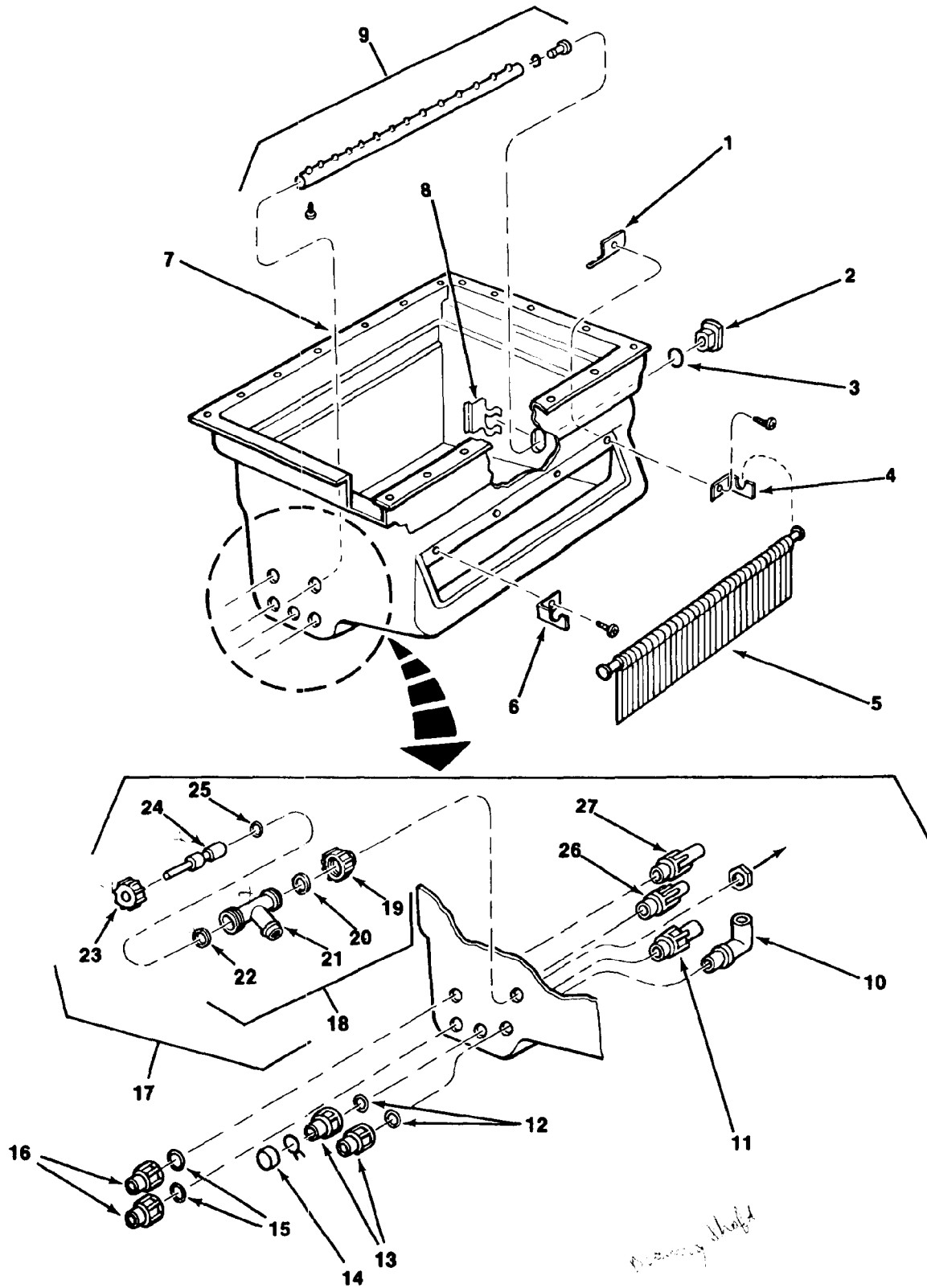

MCD200C

PARTS ILLUSTRATIONS AND PARTS LISTS

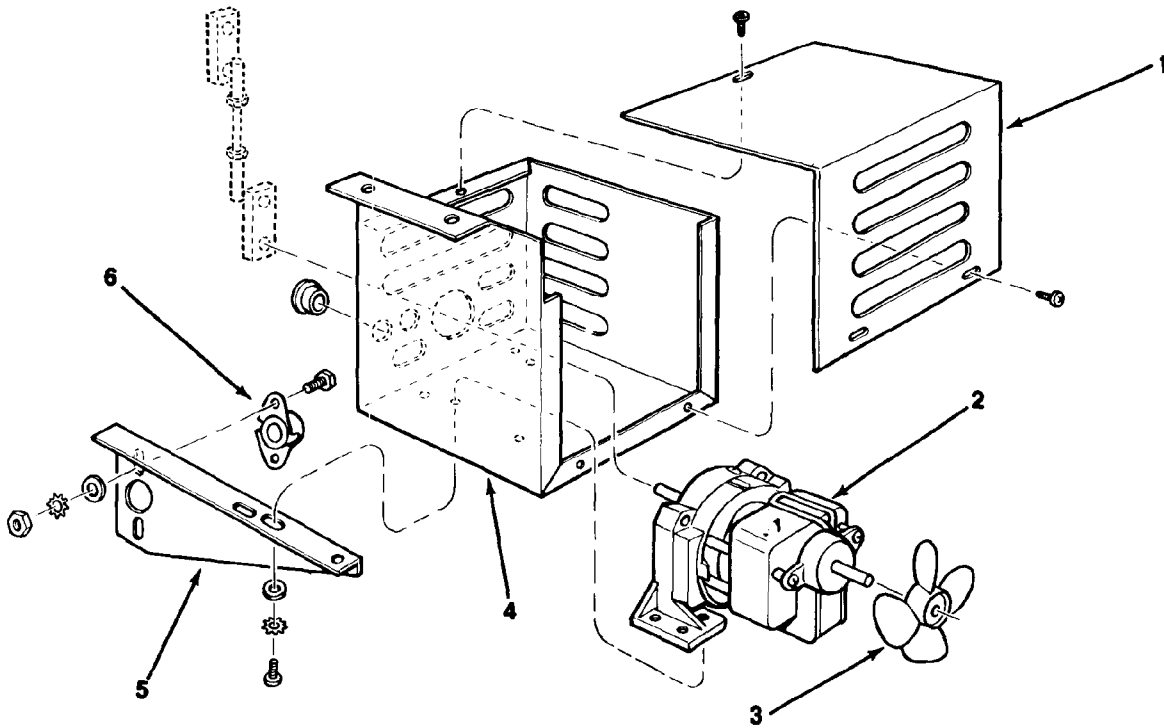

AGITATOR DRIVE ASSEMBLY

ITEM NUMBER	PART NUMBER	DESCRIPTION
1	No Number	Agitator Cover
		Attaching Parts, Index #1
	03-1401-10	Screw, #6 x 1/4 T/F Tap (3)
2	A24743-001	Agitator Motor
3	12-0675-25	Fan Blade
4	No Number	Agitator Box Assembly
		Attaching Parts, Index #2 and #4
	03-1410-02	Lockwasher, No. 10 Helical Spring (2)
	03-1403-16	Screw, #8-32 x 3/8
		Phil Recess Pan Head (2)
5	No Number	Support Bracket
		Attaching Parts, Index #5
	03-1407-03	Washer, #10 Plain (3)
	03-1410-02	Lockwasher, #10 Helical Spring (3)
	03-1403-16	Screw, #8-32 x 3/8
		Phil Recess Pan Head (3)
6	02-2453-01	Bearing Shaft
		Attaching Parts, Index #6
	03-1407-13	Washer, #1/4 Plain
	03-1417-13	Lockwasher, #1/4 External Tooth
	03-1405-04	Screw, #1/4-20 x 20 Hex Cap
	03-1406-09	Nut, #1/4-20 Hex

MCD200C PARTS ILLUSTRATIONS AND PARTS LISTS

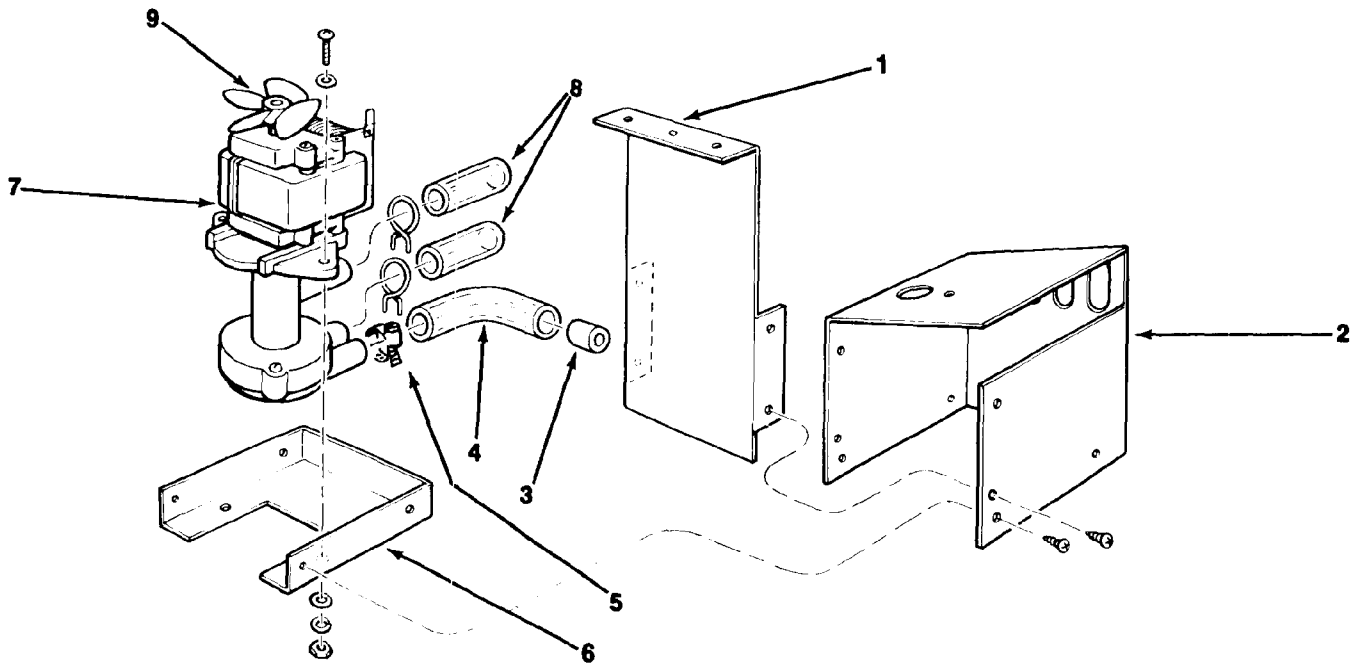

WATER PUMP

ITEM NUMBER	PART NUMBER	DESCRIPTION
1	No Number	Pump Mounting Bracket Attaching Parts, Index #1
	03-1404-05	Screw, #6 x 3/8 T/F Tap
2	No Number	Bracket Pump Box Attaching Parts, Index #2
	03-1407-03	Washer, #10 Plain
	03-1410-02	Washer, #10 Helical Spring
	03-1403-32	Screw, #10 24 x 3/4 Phil Recess Pan Head
3	A28123-001	Water Pump Restrictor
4	A27068-002	Pre-formed Tubing Attaching Parts, Index #4
	02-1530-01	Clamp, 15/16 inch I.D. S.S.
	02-0536-01	Clamp, 7/8 inch E.D. S.S.
5	02-0179-00	Hose Clamp
6	No Number	Pump Box Bracket Attaching Parts, Index #5
	03-1407-03	Washer, #10 Plain
	03-1410-02	Washer, #10 Helical Spring
	03-1403-32	Screw, #10 24 x 3/4 Phil Recess Pan Head
7	A28961-001	Water Pump Assembly
8	13-0674-07	Tygon Tubing (2-3/4 inch long, order by foot)
9	02-1719-00	Fan Blade

MCD200C

PARTS ILLUSTRATIONS AND PARTS LISTS

DRIVEMOTOR ASSEMBLY

ITEM NUMBER	PART NUMBER	DESCRIPTION
1	03-1403-43	Screw
2	12-1503-00	Seal (2)
3	02-2459-01	Insulating Cap
4	12-1503-00	Seal (2)
5	03-1408-21	Special Washer
6	03-1408-04	Shim A/R
7	03-1408-39	Special Washer
8	03-1408-40	Shim A/R
9	02-2445-01	Shaft Output
10	03-1515-03	Ring Retainer
11	03-1602-01	Key Woodruff
12	02-2444-01	Output Gear
13	02-2441-01	Third Pinion Assembly, Second Gear
14	03-1408-04	Shim A/R
15	03-1408-21	Special Washer
16	02-1305-00	O-Ring
17	A28166-001	Gear Case Assembly
18	03-1408-39	Special Washer
19	03-1408-40	Special Shim
20	03-1408-41	Washer
21	03-1408-38	Shim A/R
22	02-2443-01	First Gear, Second Pinion
23	03-1408-38	Shim A/R
24	03-1408-41	Washer
25	A28165-001	Gear Case Cover Assembly
		Attaching Parts, Index #17 and #25
	03-0774-11	Roll Pin (2)
	03-1252-00	Screw, #1/4-20 x 3/4 Flange (2)
	03-1251-00	Screw, #1/4-20 x 5/8 Flange (6)
26	A28160-001	Rotor Assembly
26a	02-1501-00	Bearing
26b	03-1408-08	Special Washer
26c	A28160-001	Rotor
27	12-1400-01	Stator 115/60/1
28	A28168-001	Fan Boring
29	A17047-001	Housing Assembly
30	A28154-021	Drive Motor Assembly (Complete)

MCD200C

PARTS ILLUSTRATIONS AND PARTS LISTS

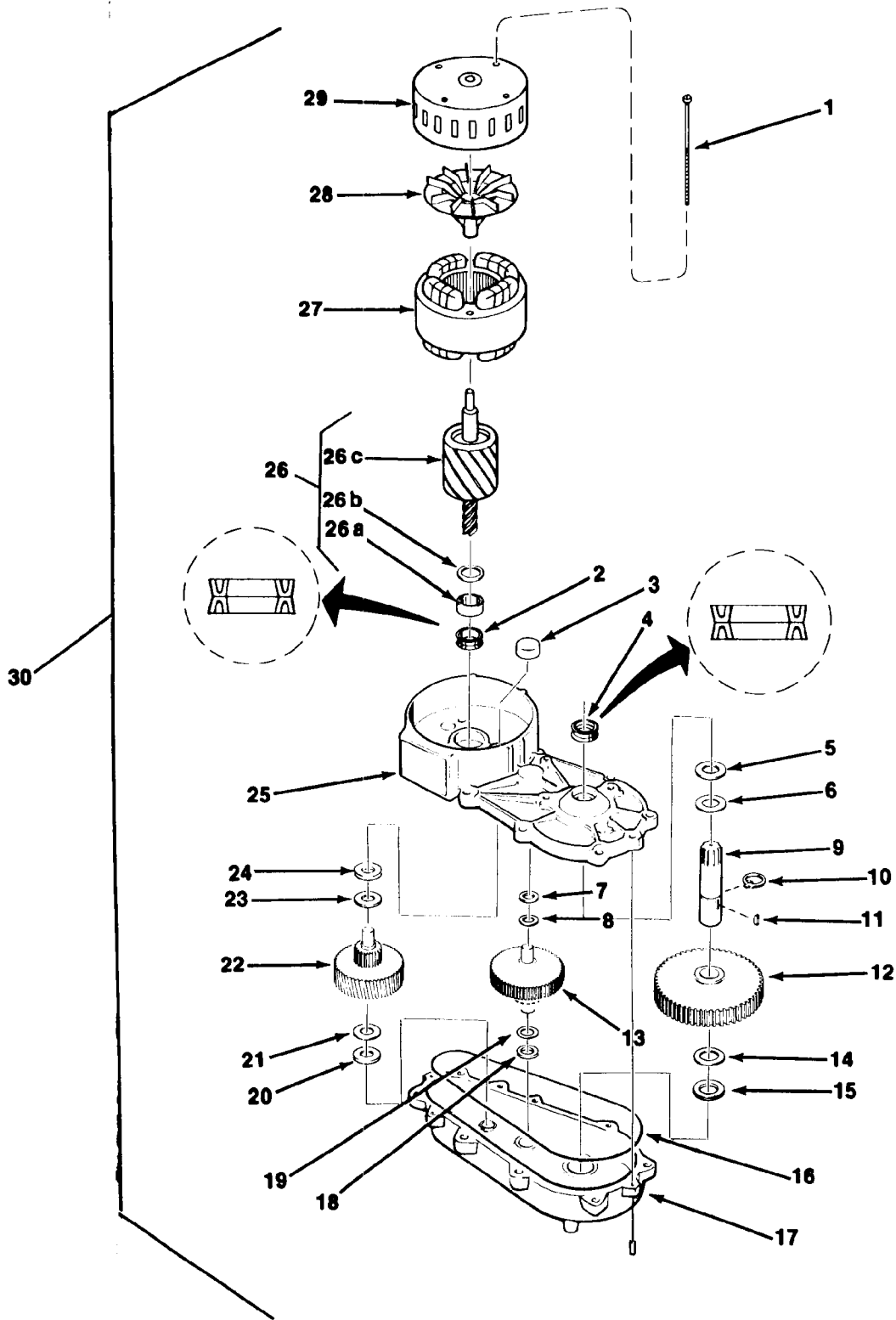

MCD200C

PARTS ILLUSTRATIONS AND PARTS LISTS

AGITATOR - CYLINDRICAL BIN ASSEMBLY

ITEM NUMBER	PART NUMBER	DESCRIPTION
1	A27566-001	Ice Breaker Assembly
2	A27584-001	Storage Bin Cylinder
3	02-2400-01	Cap Assembly
4	02-2409-01	Ice Agitator Cone
5	A27561-001	Ice Agitator Assembly
5a	13-0653-00	Rubber Spray Bar
5b	02-2723-01	Hub Cylinder Drive
5c	<i>No Number</i>	Ice Agitator
		Attaching Parts, Index #5b and #5c
	03-1418-14	Screw, #1/4-20 x 3/8 Phil Recess Flat Head
6	<i>No Number</i>	Bottom Assembly
6a	A27189-001	Clip, Bin Holdown
		Attaching Parts Index #6a
	03-1417-14	Lockwasher, #6 Internal Tooth
	03-1531-04	Screw, #6 x 3/8 T/F Tap
6b	02-2431-01	Bottom, Bin Stationary
6c	03-1596-01	Latch
		Attaching Parts, Index #6c
	03-1417-14	Lockwasher, #6 Internal Tooth
	03-1531-04	Screw, #6x3/8 T/F Tap
6d	A29108-001	Clip Locator
		Attaching Parts, Index #6d
	03-1417-14	Lockwasher, #6 Internal Tooth
	03-1531-04	Screw, #6x3/8 T/F Tap

MCD200C PARTS ILLUSTRATIONS AND PARTS LISTS

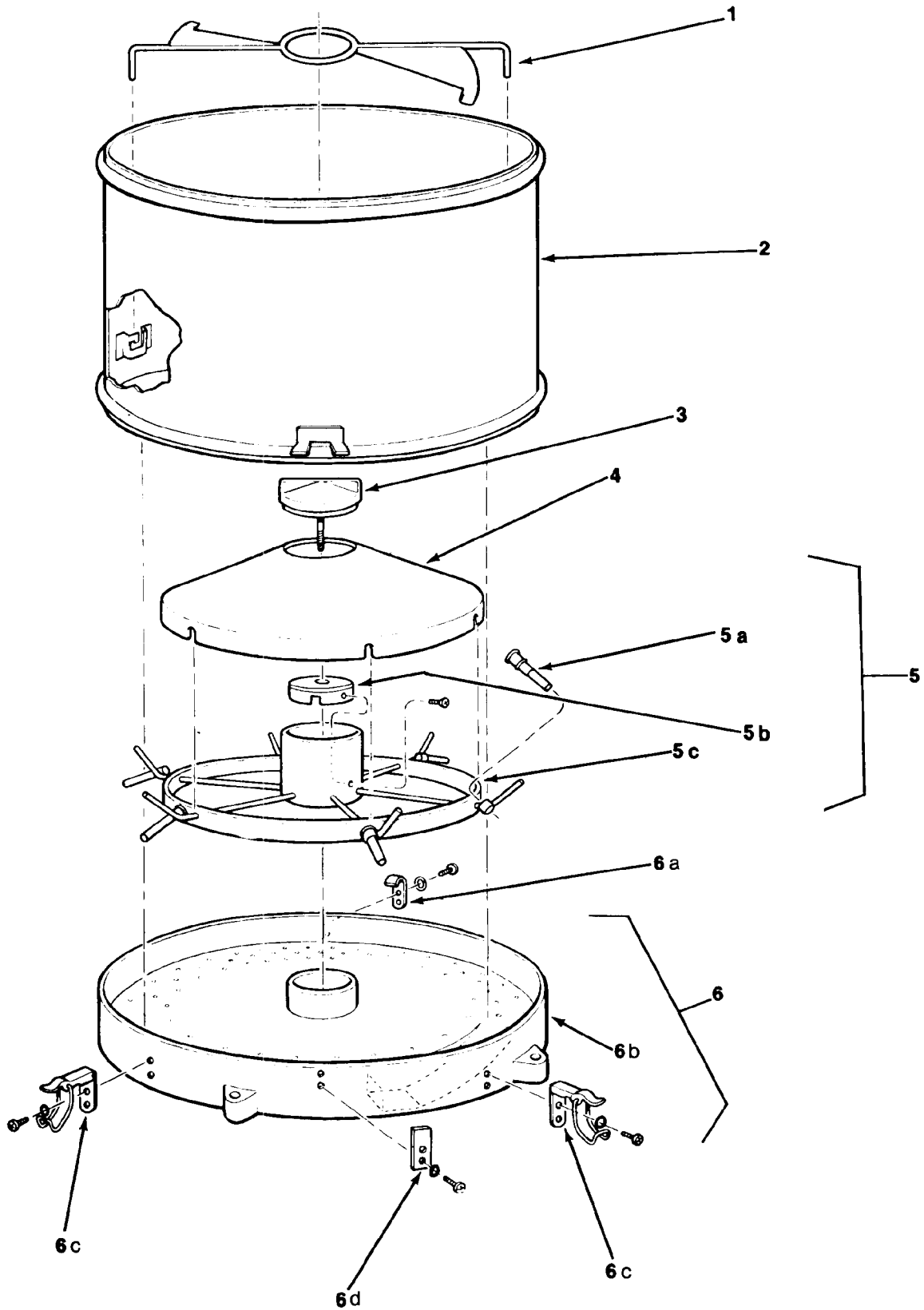

MCD200C

PARTS ILLUSTRATIONS AND PARTS LISTS

STORAGE BIN AND DISPENSING ASSEMBLY

ITEM NUMBER	PART NUMBER	DESCRIPTION
1	<i>No Number</i>	Angle, Bin Top Attaching Part
	03-1404-07	Screw, #6 x 1/2 T/F Tap
2	A30381-001	Shutter
3	A31198-001	Rod Shutter
4	03-1601-01	Pin
5	A27576-001	Bearing, Shutter Rod Attaching Part
	A26828-001	Nut, #3/4-10 Hex
6	<i>No Number</i>	Spacer, Bin Bottom
7	A27542-020	Liner Assembly, Bin Foamed
8	A27623-003	Panel, Front Cover Attaching Part
	03-1404-08	Screw, #8 x 3/8 T/F Tap
9	15-0635-01	Decal, MCD200 Ice Dispenser
10	02-2813-01	Spring Ice Lever
11	03-0396-08	Cotter Pin
12	A31197-001	Pivot, Shutter
13	A31195-001	Lever, Ice
14	15-0727-01	Handle, Lever Ice
15	A31196-001	Lever, Pivot to Stop
16	A16857-000	Pin
17	03-1405-22	Screw, #5/16-18 x 2-1/2 Hex Cap
18	13-0674-06	Tube, Tygon (20-inch) (Order by the foot)
19	<i>No Number</i>	Spacer, Bin Support Attaching Parts
	03-1600-01	Clip, Hairpin
	03-1410-04	Lockwasher, #5/16 Helical Spring
20	02-1957-00	Tube Drain
21	13-0617-13	O-Ring
22	<i>No Number</i>	Ice Breaker, Agitator, see pg 17 Cylindrical Bin Assembly Attaching Parts
	03-1600-01	Clip, Hairpin
23	02-1751-00	Fitting Drain
24	A24094-001	Pin, Drive
25	A30215-020	Shaft Assembly, Bin
26	02-2410-01	Liner, Spout Hole
27	A31270-001	Switch
28	<i>No Number</i>	Switch Bracket
29	<i>No Number</i>	Bracket Hold Down

MCD200C

PARTS ILLUSTRATIONS AND PARTS LISTS

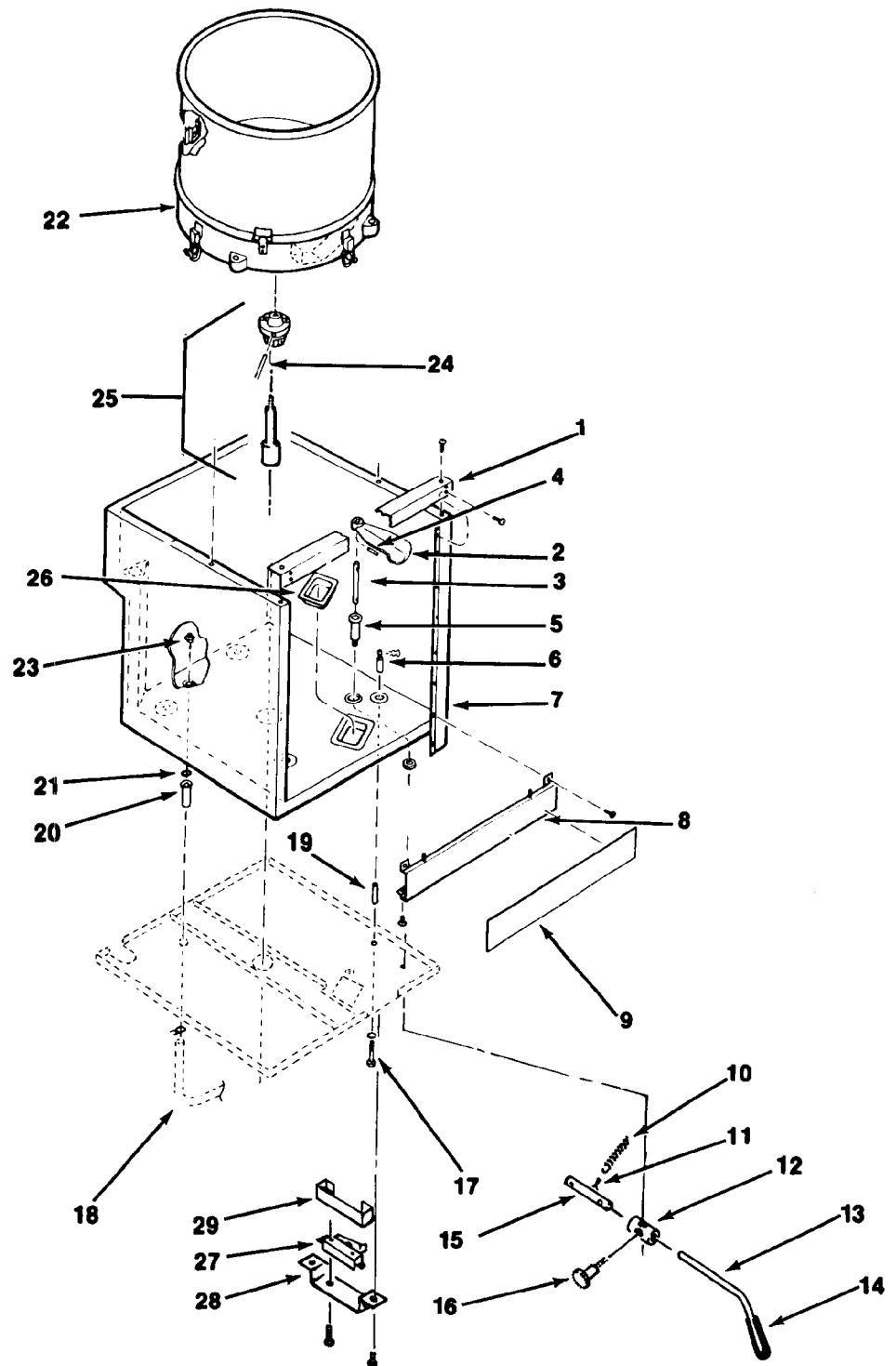

MCD200C

PARTS ILLUSTRATIONS AND PARTS LISTS

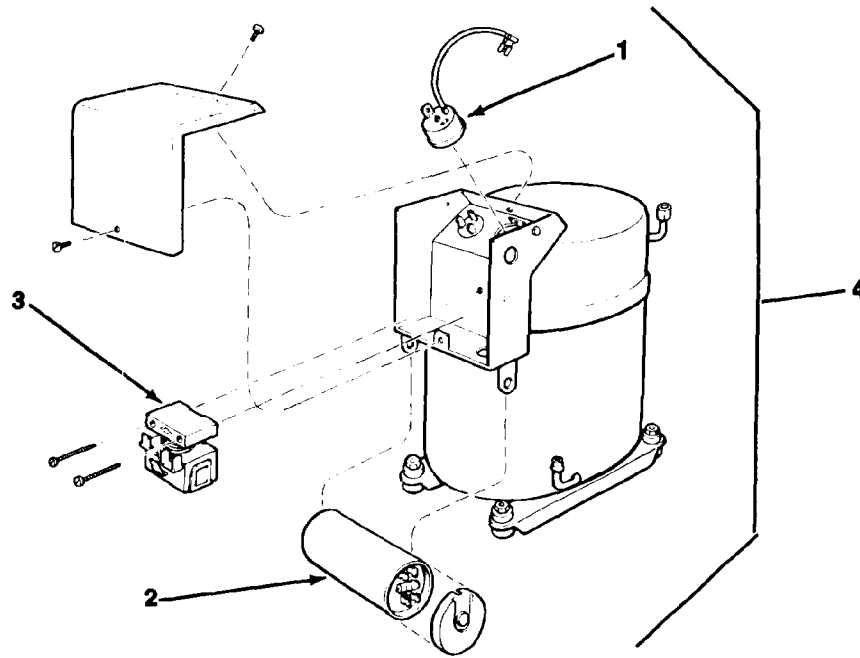

COMPRESSOR ASSEMBLY

ITEM NUMBER	PART NUMBER	DESCRIPTION
1	18-2200-25	Overload
2	18-1901-33	Capacitor w/cap
3	18-2200-26	Relay
4	18-4600-01	Compressor

MCD200C PARTS ILLUSTRATIONS AND PARTS LISTS

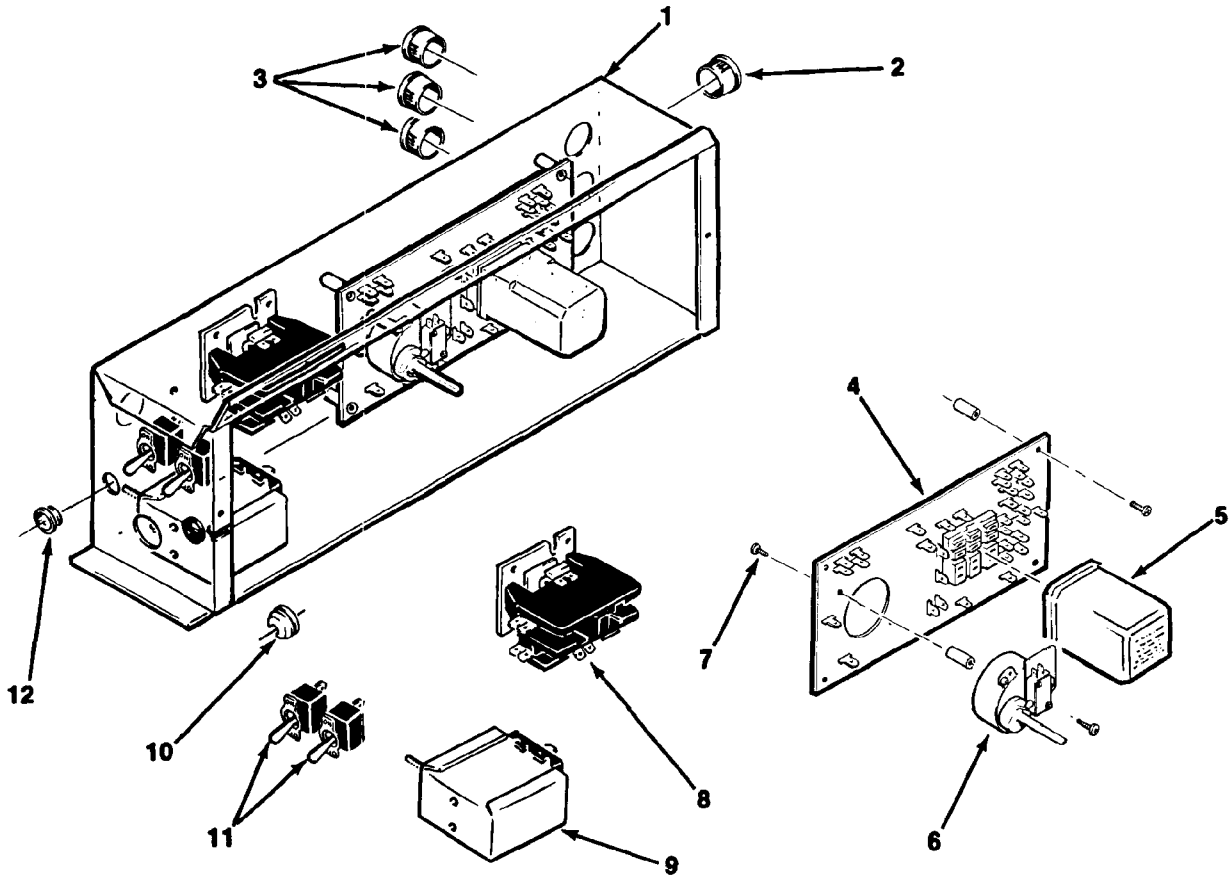

CONTROL BOX

ITEM NUMBER	PART NUMBER	DESCRIPTION
1	No Number	Control Box
2	12-1213-10	Bushing
3	12-1213-10	Bushing
4	12-1912-01	Circuit Board
5	12-1879-02	Relay
6	12-1980-01	Timer and Switch Assembly
		Attaching Parts Index #4 and #6
	03-1403-02	Screw, #6-32 x 1/4
7	03-1403-02	Screw, #6-32 x 3/4
8	12-2048-01	Contactor
		Attaching Parts Index #1 and #8
	03-1403-17	Screw, #8-32 x 3/8
9	11-0389-02	Pressure Control, Air-Cooled
	11-0388-02	Pressure Control, Water-Cooled
		Attaching Parts Index #1 and #9
	03-1403-02	Screw, #6-32
10	13-0557-00	Grommet
11	12-0426-01	Toggle Switch
12	12-1213-04	Bushing

MCD200C WIRING DIAGRAMS

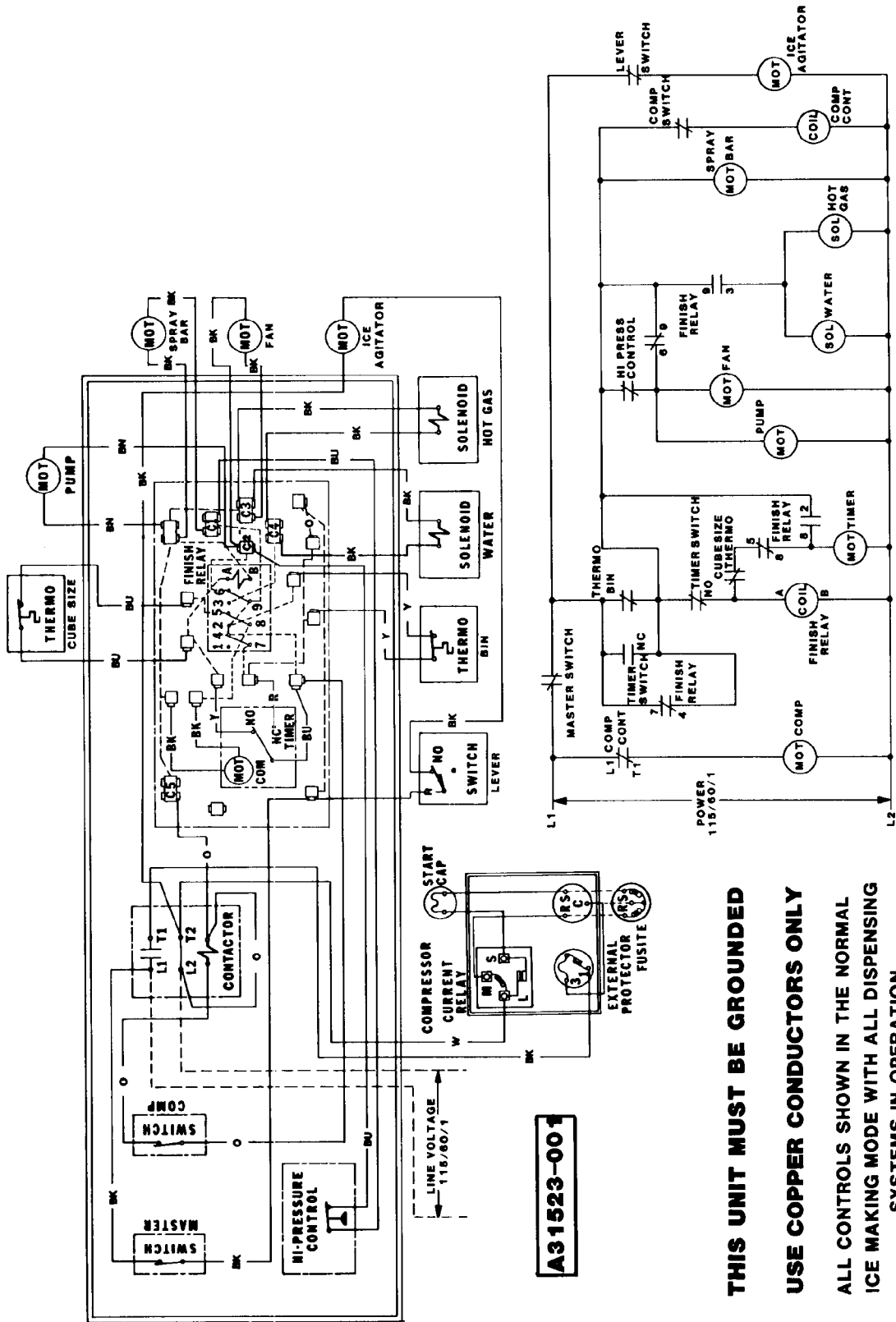

Wiring Diagram MCD200SAE-1C (115/60/1) Air-Cooled

MCD200C WIRING DIAGRAMS

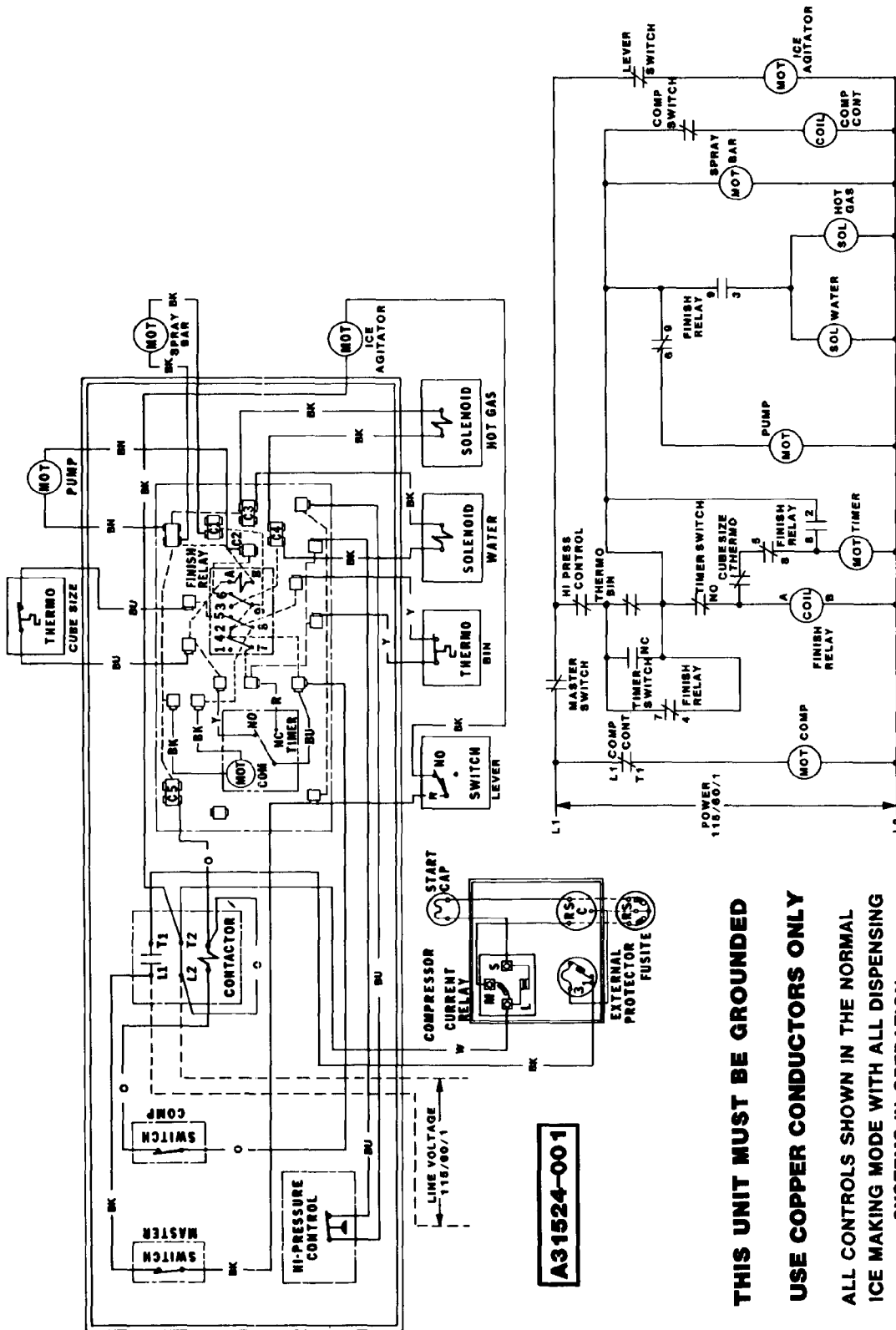

THIS UNIT MUST BE GROUNDED
USE COPPER CONDUCTORS ONLY
 ALL CONTROLS SHOWN IN THE NORMAL
 ICE MAKING MODE WITH ALL DISPENSING
 SYSTEMS IN OPERATION

Wiring Diagram MCD200SWE-1C (115/60/1) Water-Cooled