

MCM1462 SERVICE PARTS

This parts lists shows the service parts for the MCM1462 air or water cooled.

Check the model number of the machine to be certain of obtaining the correct part.

Included at the back of the parts list are the wiring diagrams.

Table of Contents

Cabinet	Page 2
Refrigeration System	Page 3
Air and Water Cooled Parts	Page 4
Water System	Page 5
Control Box	Page 6
MDB900 Bin	Page 7
Wiring Diagrams	Page 8

MCM1462 SERVICE PARTS

CABINET PARTS

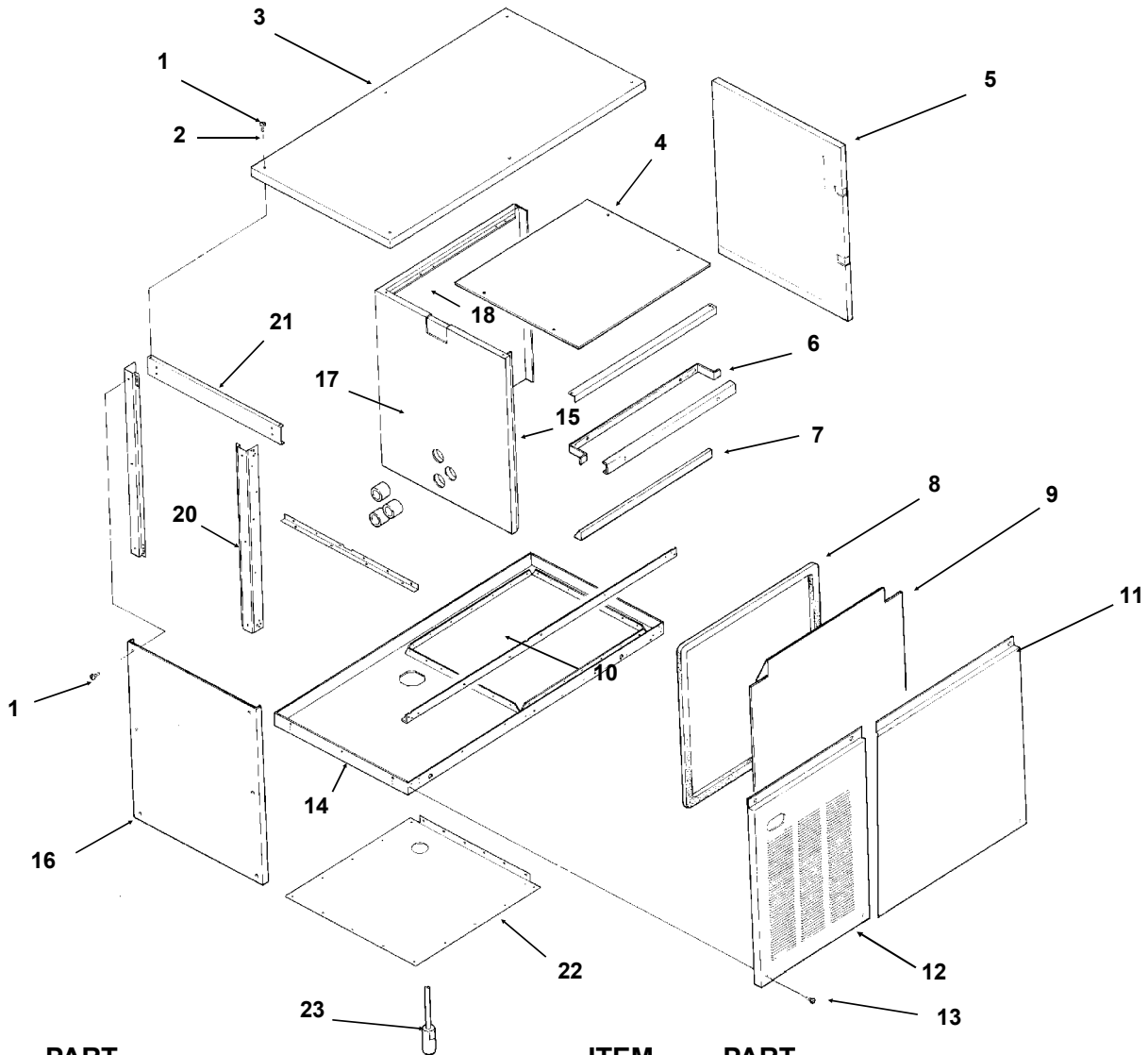

ITEM NUMBER	PART NUMBER	DESCRIPTION	ITEM NUMBER	PART NUMBER	DESCRIPTION
1	03-1531-01	Screws	12	A35400-002	Left front panel
2	03-1417-27	Washers		02-3236-01	Plastic bumper
3	A35074-002	Panel top (stainless)	13	03-1678-02	Screw
4	A33364-001	Liner top		03-1678-03	Screw retainer
5	A29164-002	Right panel (stainless)	14	A35110-001	Base assembly
6	A29204-001	Brace front	15	02-2533-01	Liner, left side
7	02-2532-01	Liner cap	16	A35075-002	Left side panel, stainless
8	13-0595-00	Gasket (order per foot)	17	no number	Retainer
9	02-2795-01	Liner, front panel	18	02-2531-01	Liner back
10	03-1678-01	Speed clip (for front panels)	19	02-2534-01	Right side liner
11	A35401-023	Right front panel (includes liner, gasket)	20	A35069-001	Corner post
	03-1678-04	Thumb screw	21	A35066-001	Brace
	03-1678-03	Screw retainer	22	02-3151-01	Plastic cover
	02-3236-01	Plastic bumper	23	A34908-021	Transducer

MCM1462 SERVICE PARTS

REFRIGERATION SYSTEM

ITEM NUMBER	PART NUMBER	DESCRIPTION	ITEM NUMBER	PART NUMBER	DESCRIPTION
1	A35122-001	Evap. manifold assy	10	12-2290-22	Hot gas valve
2	16-0887-01	Manifold assy		02-3231-03	Hot gas valve filter
3	16-0816-21	Expansion valve	11	16-0817-21	Accumulator
	13-0617-51	O-Ring	12	16-0560-00	Valve core
	02-2920-01	Foam insulation	13	16-0563-00	Valve cap
4	02-3319-02	Drier	14	12-2300-02	Hi temp cut out
5	03-1405-20	Screw	15	A30296-020	Evaporator plate
6	03-1407-07	Washer	16	11-0465-21	Hi press. cut out (A.C.)
7	18-2200-27	Sleeve	17	16-0790-01	Distributor, included in item 1.
8	18-2200-28	Grommet			
9	18-8864-22	Compressor, three phase			

no number Comp. overload (internal)

Replacement compressors include a crankcase heater, not used on this model. It may be used or disconnected when installed.

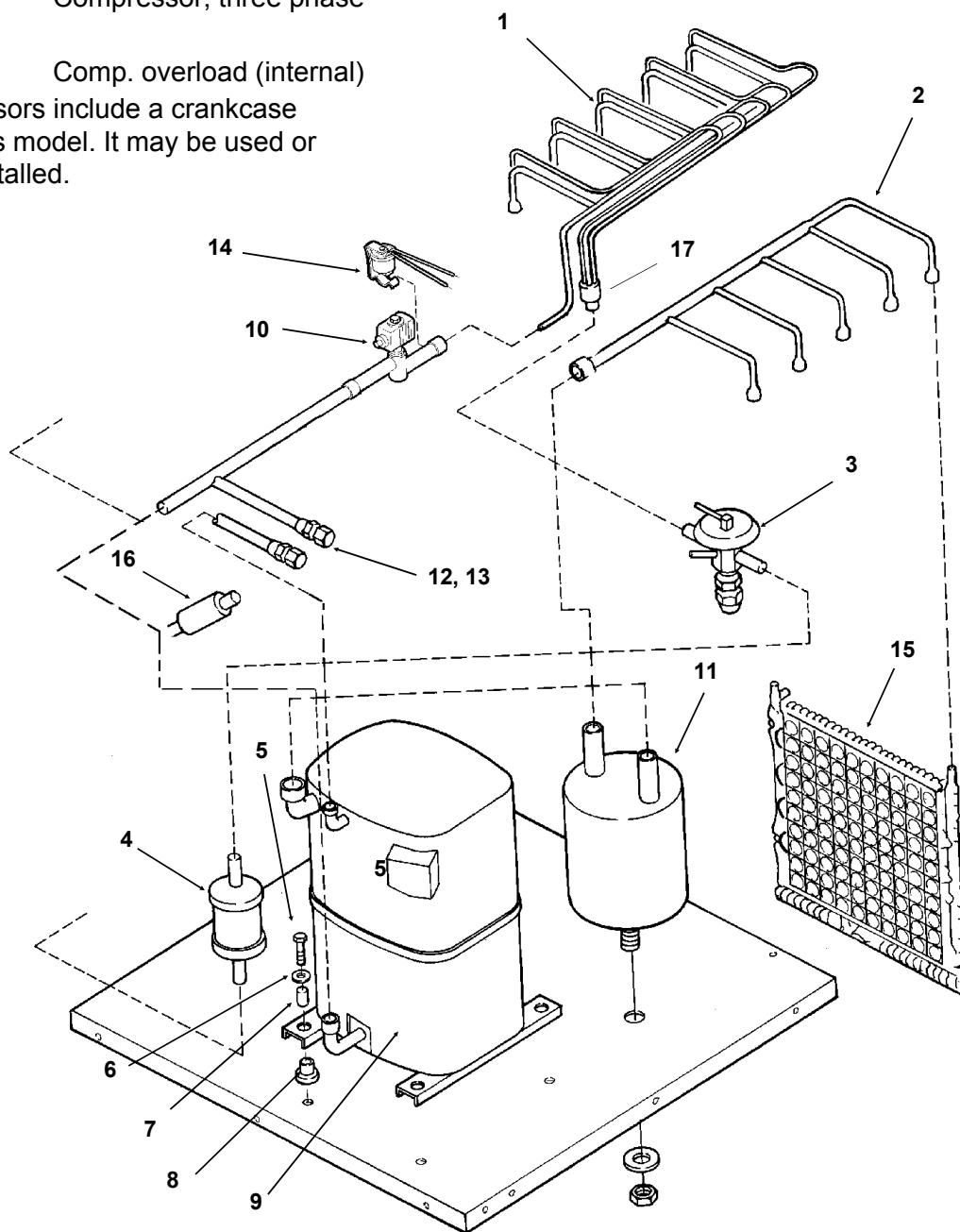

MCM1462 SERVICE PARTS

CONDENSING ASSEMBLY

AIR COOLED MODELS

ITEM NUMBER	PART NUMBER	DESCRIPTION
1	A35103-001	Fan Bracket
2	18-5105-02	Fan Motor
3	18-8503-01	Fan Blade
4	A35104-001	Condenser Shroud
5	18-8502-01	Condenser
6	02-3164-01	Filter
7	A35102-001	Condenser divider

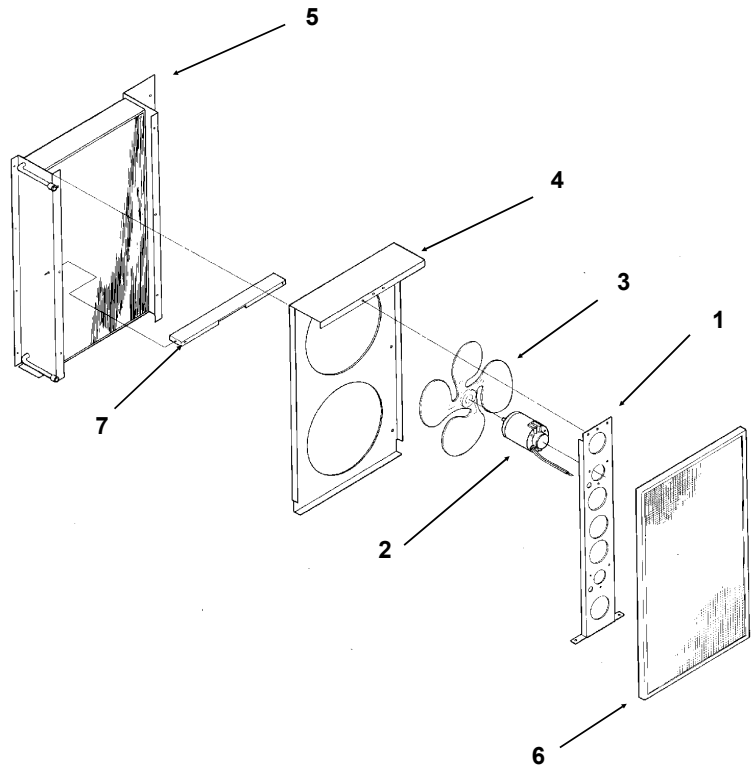

WATER COOLED MODELS

ITEM NUMBER	PART NUMBER	DESCRIPTION
1	11-0424-01	Water Regulator Valve
2	18-6302-25	Condenser, Water Cooled
3	03-1407-05	Washer
4	03-0571-01	Screw
5	A35070-001	Left back panel
6	02-2628-02	Receiver
7	A31828-001	Drain casting

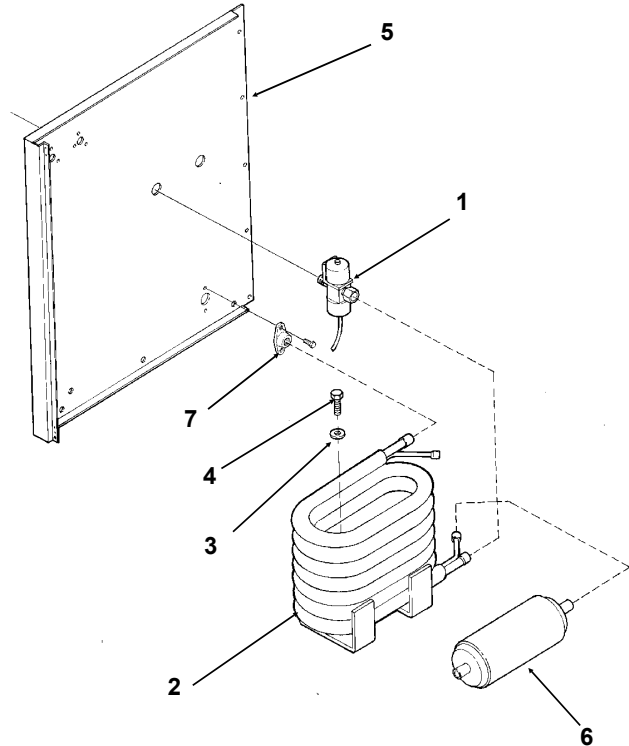

MCM1462 SERVICE PARTS

WATER SYSTEM

ITEM NUMBER	PART NUMBER	DESCRIPTION
1	02-2521-01	Long water manifold
2	02-2519-01	Tee
3	A29703-001	Short water manifold
4	02-2527-01	Water dist. tube
5	02-2814-01	Clamp
6	A29730-001	Water Tube Assy
7	A30761-020	Sump Assembly
8	02-1530-01	Clamp
9	02-1800-01	Clamp
10	A30666-001	Pump Bracket
11	03-0571-01	Screw

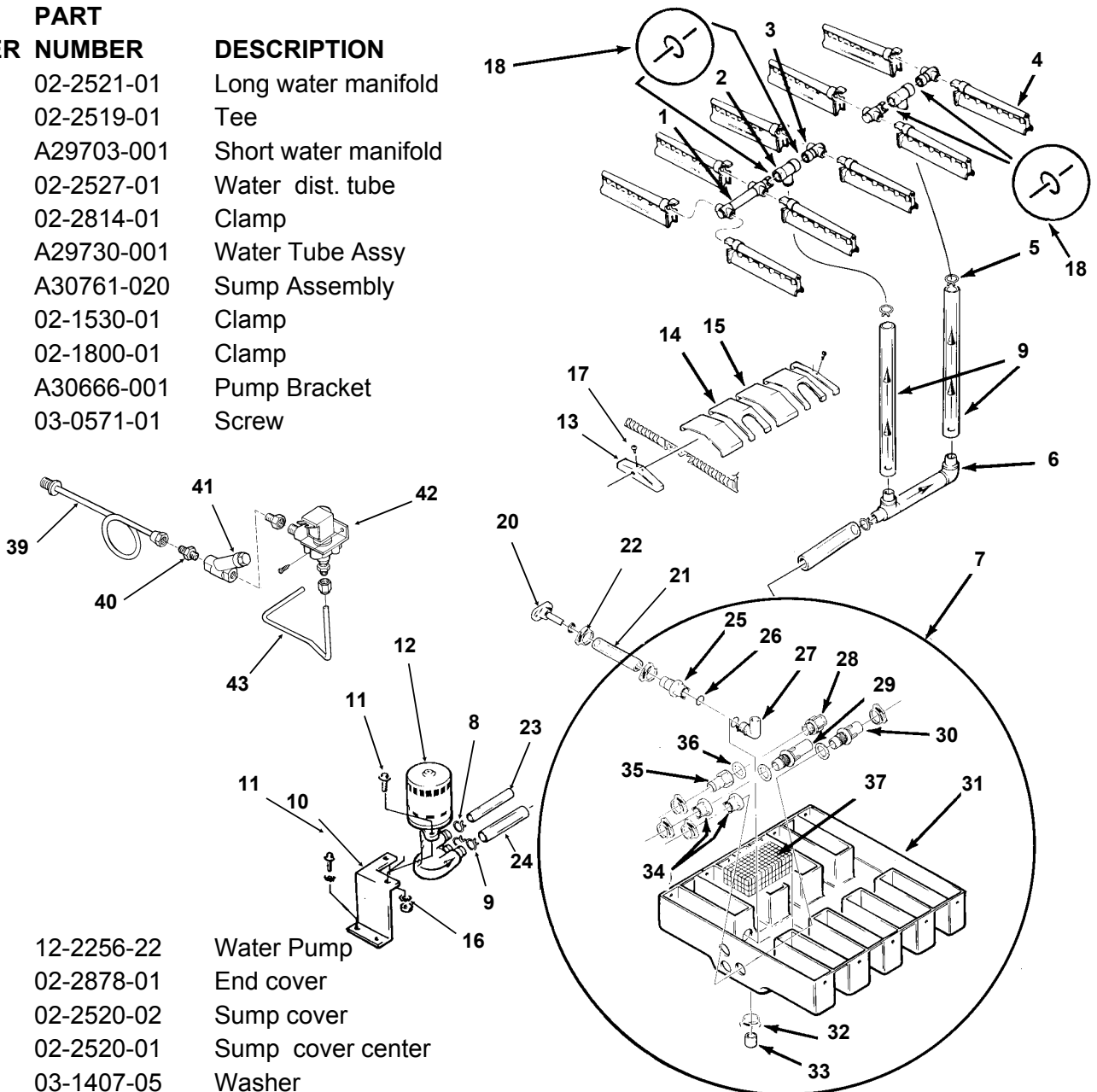

12	12-2256-22	Water Pump
13	02-2878-01	End cover
14	02-2520-02	Sump cover
15	02-2520-01	Sump cover center
16	03-1407-05	Washer
17	03-1531-01	Screw
18	13-0617-48	O-ring
19	13-0674-07	Hose (18.5")
20	A31757-002	Drain
21	13-0674-07	Tube, drain (7")
22	02-2814-12	Hose clamp
23	13-0674-07	Tube, need 6.25"
24	13-0674-08	Tube, need 6.6"
25	02-2606-01	Female tube
26	13-0617-02	O-ring
27	02-2125-01	Elbow
28	A29342-001	Overflow
29	02-2792-01	Pick Up tube

30	02-2793-01	Inlet tube
31	no number	sump pan
32	02-1530-01	Clamp
33	13-0796-01	Rubber cap
34	02-2791-01	Water inlet nut
35	02-2606-01	Female tube
36	13-0617-02	O-ring
37	A30760-001	Screen
39	A35119-001	Water inlet assy.
40	16-0791-01	Half unio
41	16-0162-00	Strainer
42	12-1646-04	Inlet water valve
43	A35117-001	Tube

MCM1462 SERVICE PARTS

CONTROL BOX

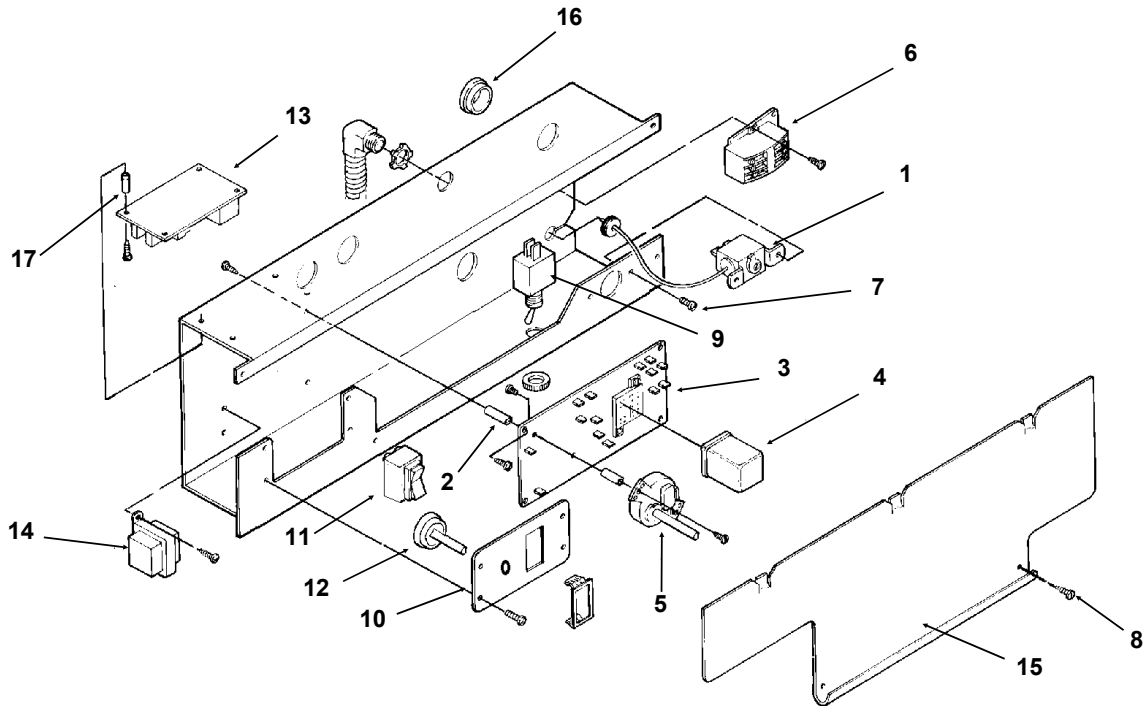

ITEM NUMBER	PART NUMBER	DESCRIPTION
1	11-0351-22	Cube Size Control
2	02-2242-02	Stand off
3	12-1912-01	Circuit board
4	12-1879-03	Relay
5	12-2317-22	Timer & Switch
6	12-0739-02	Contactor
7	03-1403-17	Screw
8	03-1638-03	Screw
9	12-0426-01	Comp. Switch
10	A34880-001	Switch plate
11	12-2375-01	Wash- Off - Ice switch
12	12-2400-01	Bin ice level switch
	02-3126-01	Knob for bin switch, not shown
13	12-2376-21	Ice level control circuit board
14	12-2285-22	Transformer
15	A35082-001	Control box cover
16	12-1213-12	Snap bushing
17	12-2350-01	Stand off

The Fan Pressure Control is located behind the control box. The part number is 11-0426-22

MCM1462 SERVICE PARTS

MDB900 ICE STORAGE BIN

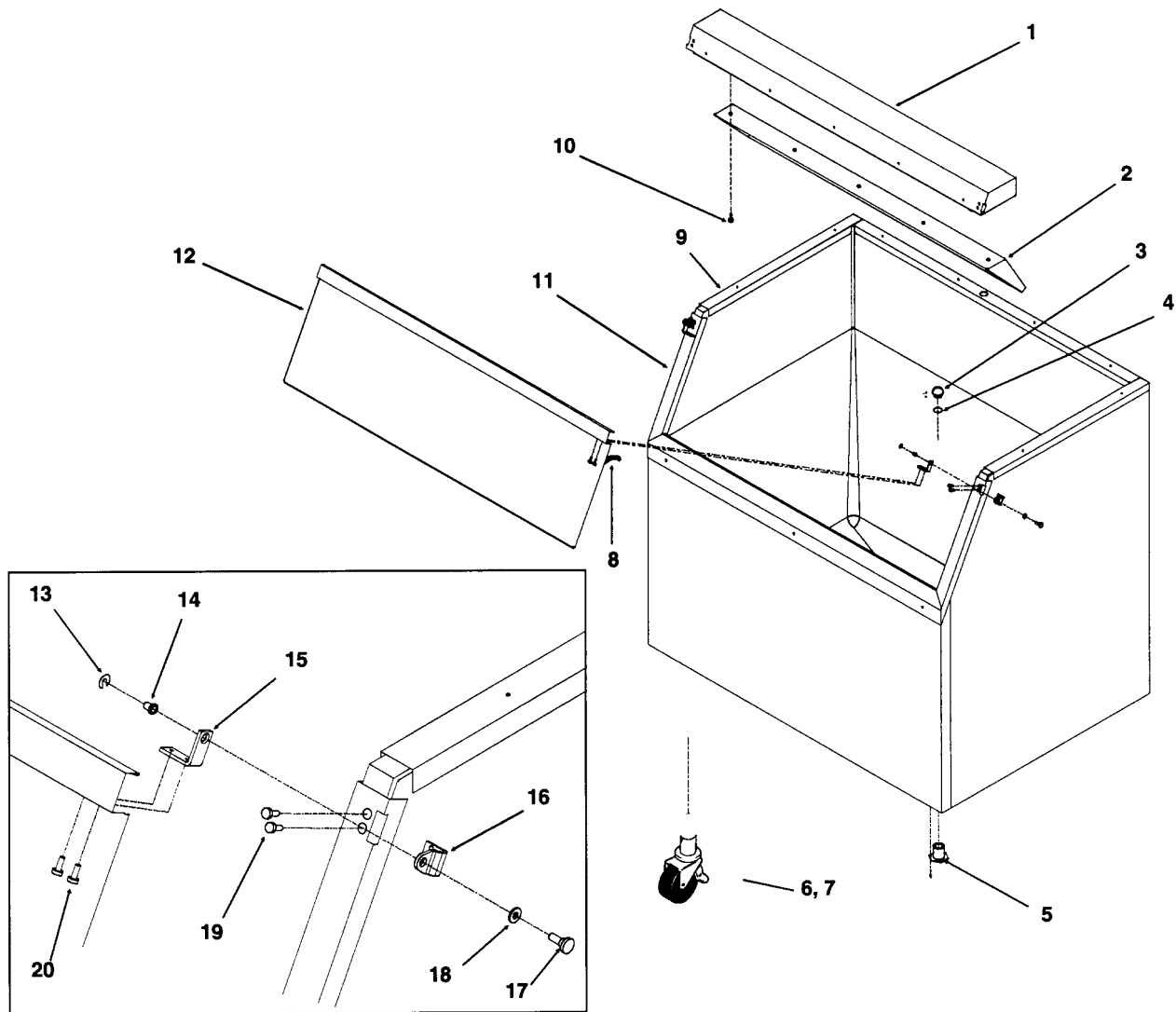

ITEM NUMBER	PART NUMBER	DESCRIPTION	ITEM NUMBER	PART NUMBER	DESCRIPTION
1	A35322-020	Canopy Assembly	14	02-2380-01	Hinge bushing
2	A35152-001	Ice Baffle	15	02-3195-01	Door hinge
3	02-2809-01	Drain Top	16	02-3196-01	Bin hinge
4	13-0617-11	O-ring	17	02-2806-01	Shoulder screw
5	02-3201-01	Drain casting	18	02-2380-02	Spacer
6	02-3111-01	Front caster, swivel	19	03-1403-29	Screw 10-24
7	02-3110-01	Back caster	20	03-1403-24	Screw 10-24
8	13-0595-00	Door gasket(6.25' reg.)	21	02-0540-00	Scoop
9	19-0503-04	Bin gasket	22	A35447-001	Scoop holder
10	03-0727-11	Baffle screw	23	A34931-001	Bumper
11	A35275-020	Door frame assy.			
12	A35323-001	Door with gasket			
13	03-1539-09	"E" ring			

MCM1462 SERVICE PARTS

Air Cooled, Three Phase

A35428-003

THIS UNIT MUST BE GROUNDED
USE COPPER CONDUCTORS ONLY

CAUTION:

MORE THAN ONE DISCONNECT MEANS
MAY BE REQUIRED TO DISCONNECT
ALL POWER TO THIS UNIT.

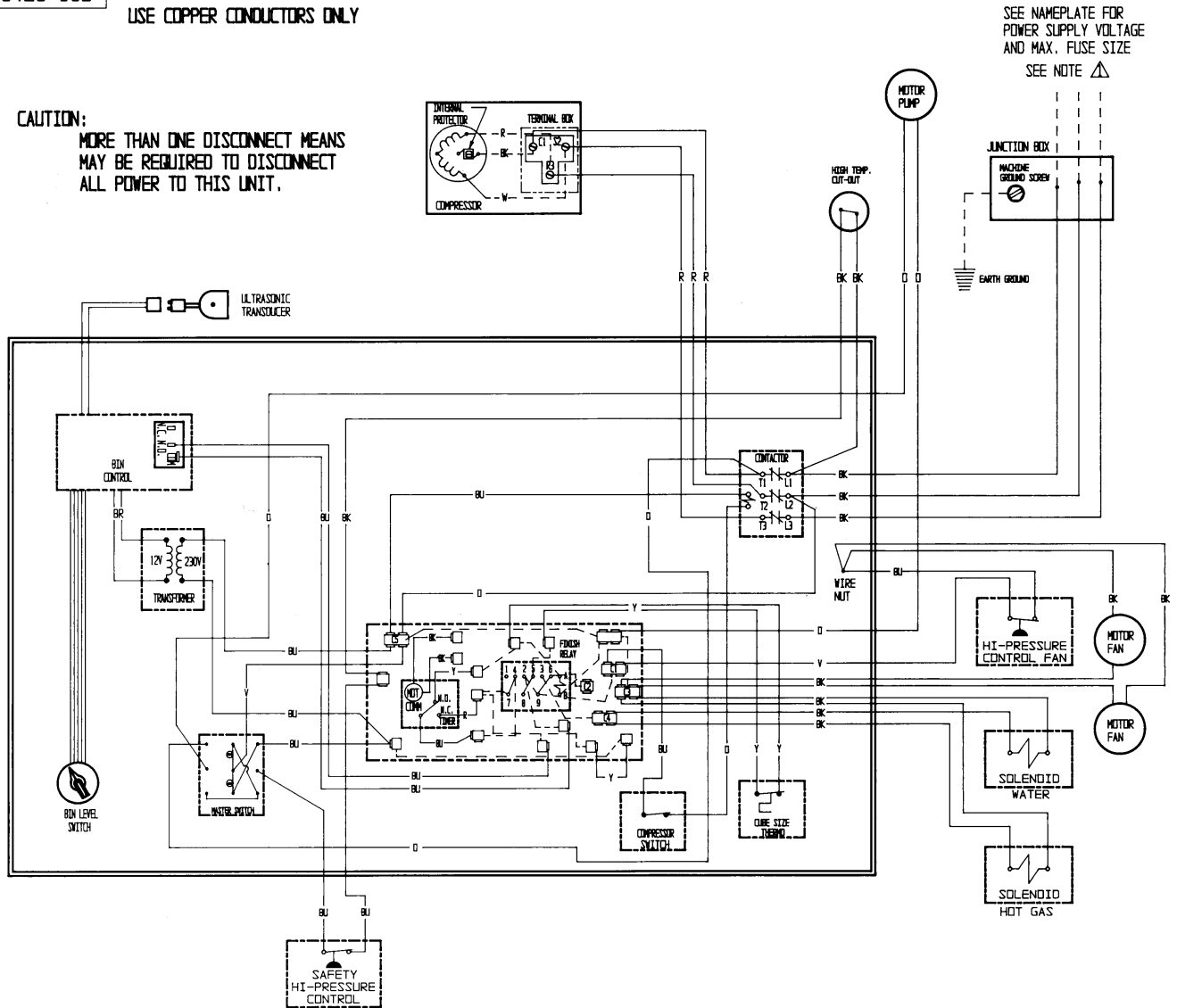

SEE NAMEPLATE FOR
POWER SUPPLY VOLTAGE
AND MAX. FUSE SIZE
SEE NOTE Δ

MCM1462 SERVICE PARTS

Air Cooled, Three Phase

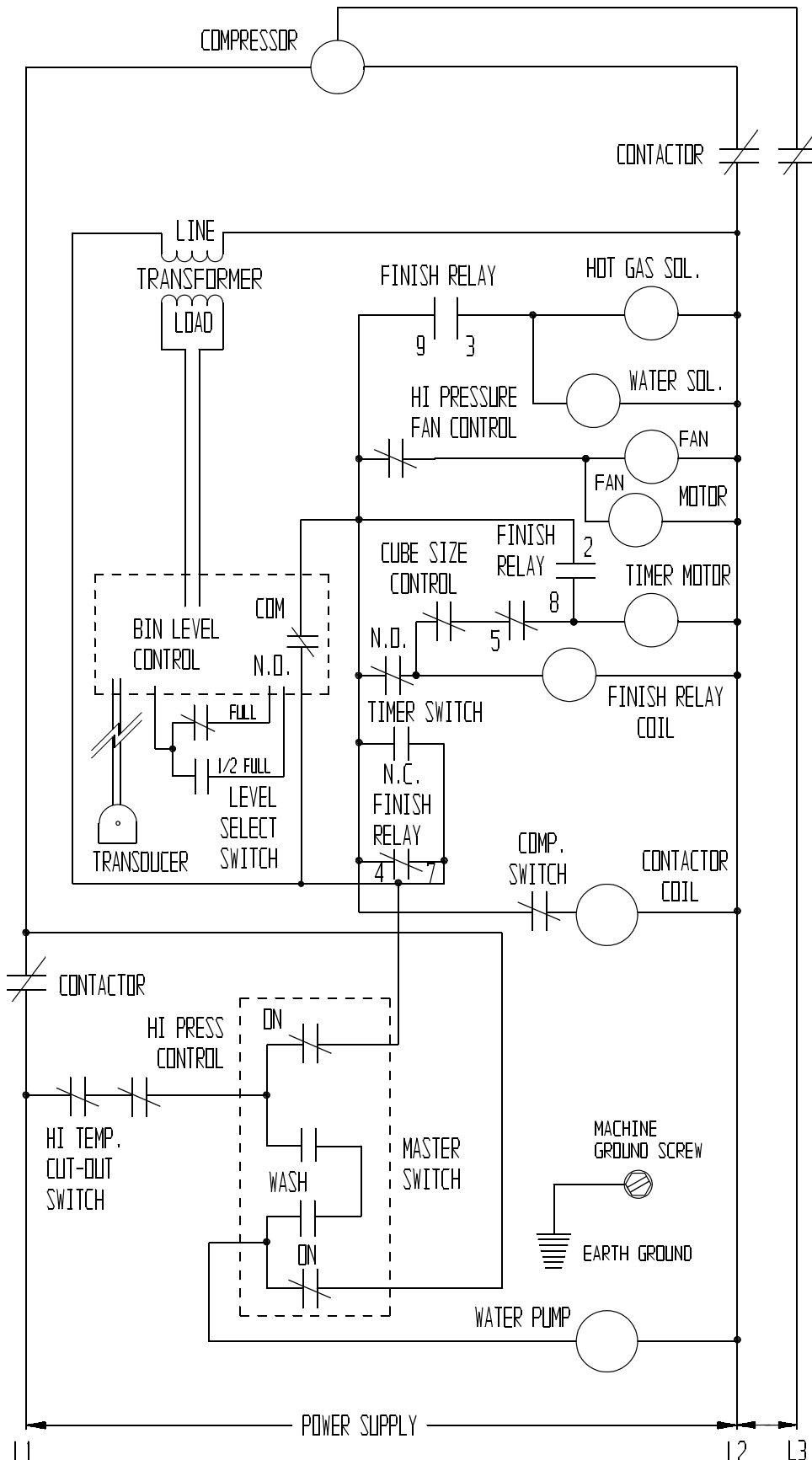

MCM1462 SERVICE PARTS

Water Cooled, Three Phase

A35436-003

THIS UNIT MUST BE GROUNDED
USE COPPER CONDUCTORS ONLY

SEE NAMEPLATE FOR
POWER SUPPLY VOLTAGE
AND MAX. FUSE SIZE

SEE NOTE 

CAUTION:

MORE THAN ONE DISCONNECT MEANS
MAY BE REQUIRED TO DISCONNECT
ALL POWER TO THIS UNIT.

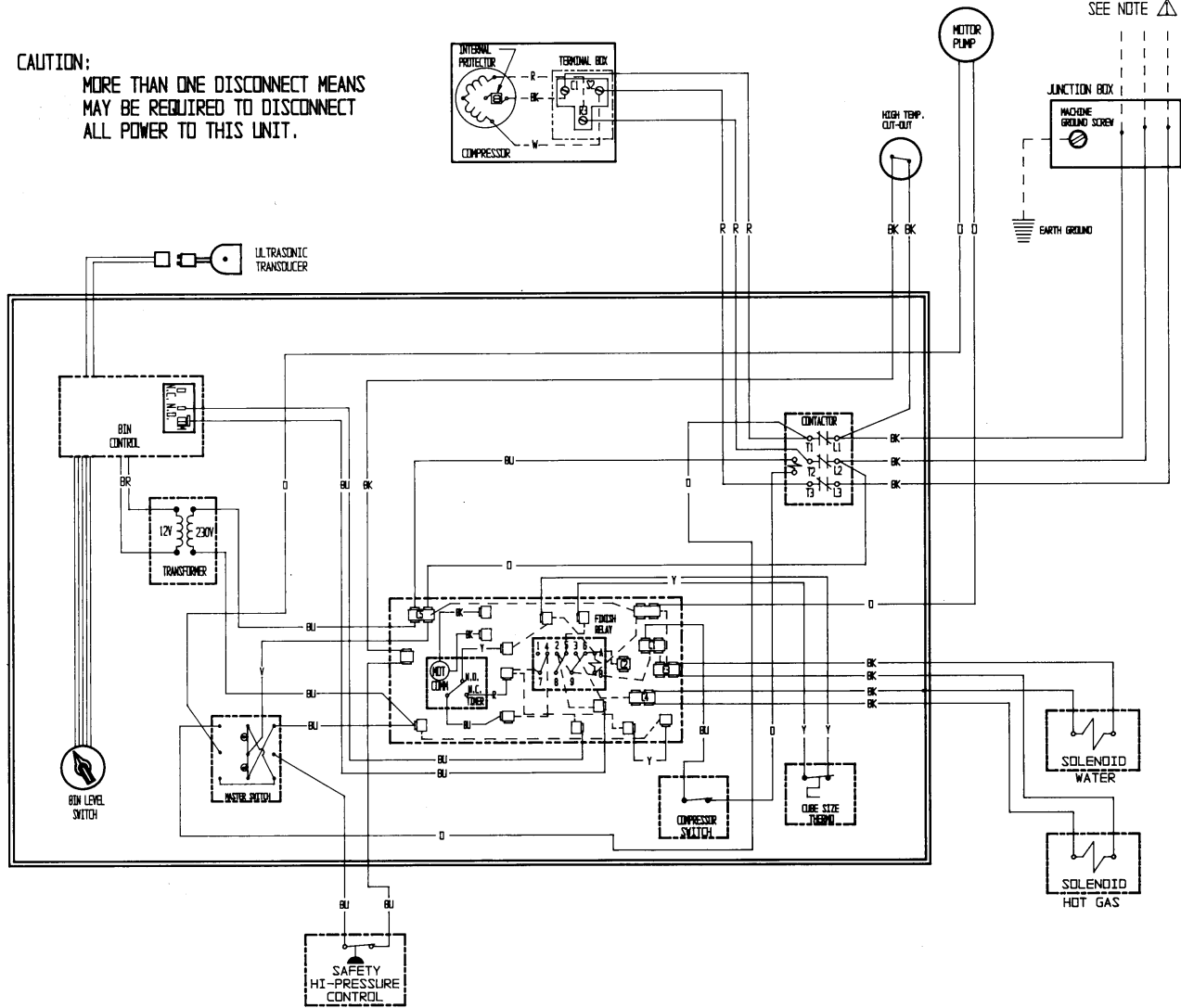

MCM1462 SERVICE PARTS

Water Cooled, Three Phase

