

MDT2 Service Parts

This is the list of service parts for the MDT2C12-1A ice maker dispenser.

Always have the model and serial number available when looking for a part number as changes do occur and the change may reference the model and/or serial number.

Table of Contents

Cabinet	Page 2
Condensing System	Page 3
Water and Dispensing	Page 4
Water and Dispensing Part Numbers	Page 5
Auger Drive and Evaporator	Page 6
Auger Drive and Evaporator Part Numbers	Page 7
Control System	Page 8
Wiring Diagram	Page 9

MDT2 Service Parts

Cabinet

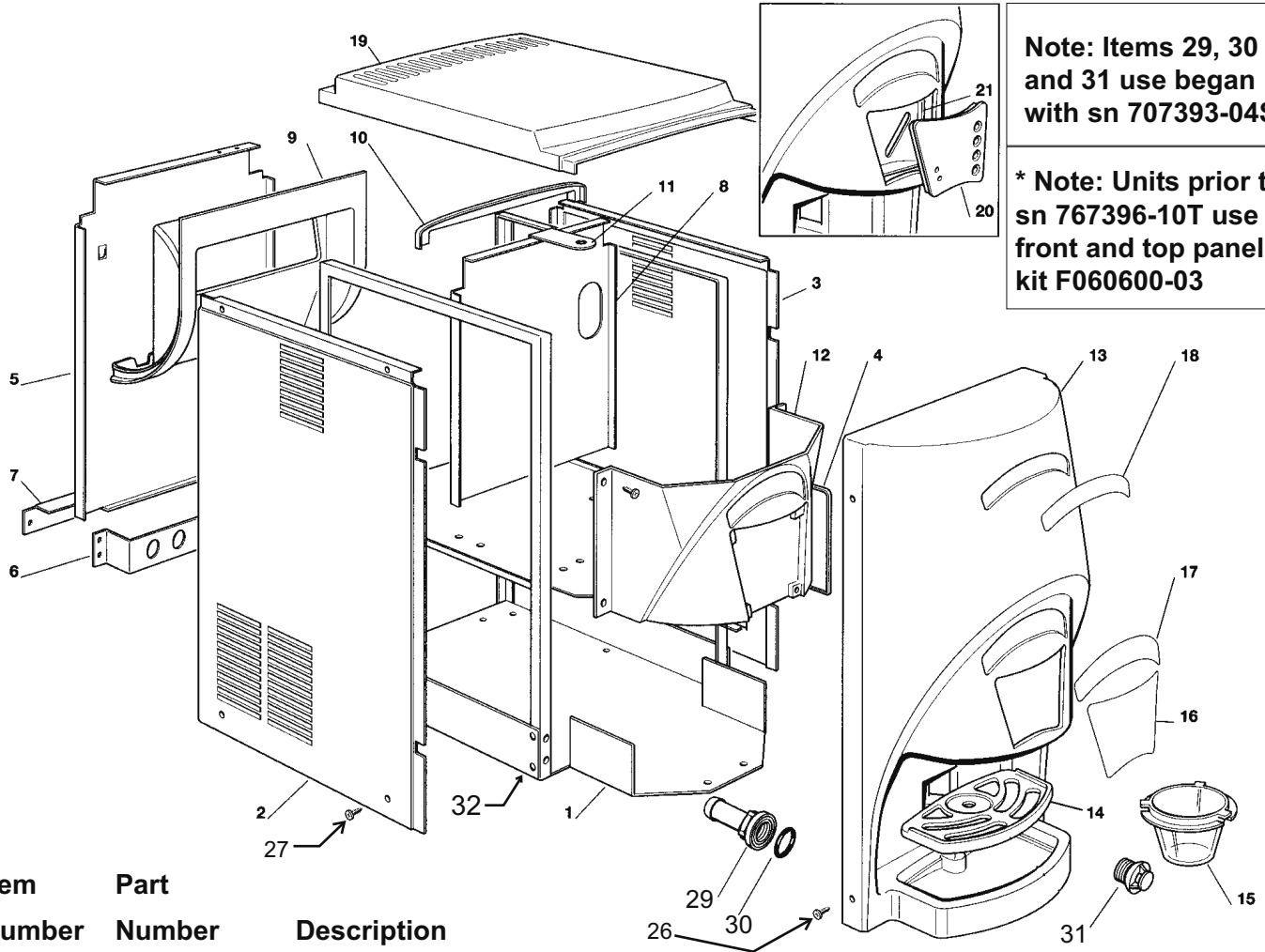

Note: Items 29, 30 and 31 use began with sn 707393-04S

*** Note: Units prior to sn 767396-10T use front and top panel kit F060600-03**

Item Number	Part Number	Description
1	F650780-00	Foam pad
2	F721737-00	Left Side Panel
3	F721738-00	Right Side Panel
4	F721763-00	R Pcb Service Panel
5	F702260-00	Rear Panel
6	F702259-00	Metal Bracket For Fitting
7	F702269-00	Cover For Fitting Bracket
8	F702257-00	Metal Divider
9	F660669-00	Condenser Shroud
10	F660674-00	Plastic Bracket
11	F702270-00	Ice Spout Bracket
12	F660672-00	Dispense Board Frame
13	F660812-01	Front Panel, no labels
14	F650765-00	Grill, Sink
15	F660675-00	Dispensing Spout
16	F650753-05	Label - Ice & Water
17	F650753-01	Label
18	F650753-00	Scotsman Logo
19	F660811-00	Top Panel*
20	F660699-00	PCB cover
21	F660700-00	PCB housing
26	F470000-03	Screw
	F650730-00	Cap for screw
	F650730-01	Washer for screw
27	F470002-11	Side panel screw
28	F470030-50	Back panel screw
29	F660219-01	Drain fitting
30	F640134-00	O-ring
31	F660211-01	Drain top
32	F650780-00	Foam pad, under base

MDT2 Service Parts

Condensing System

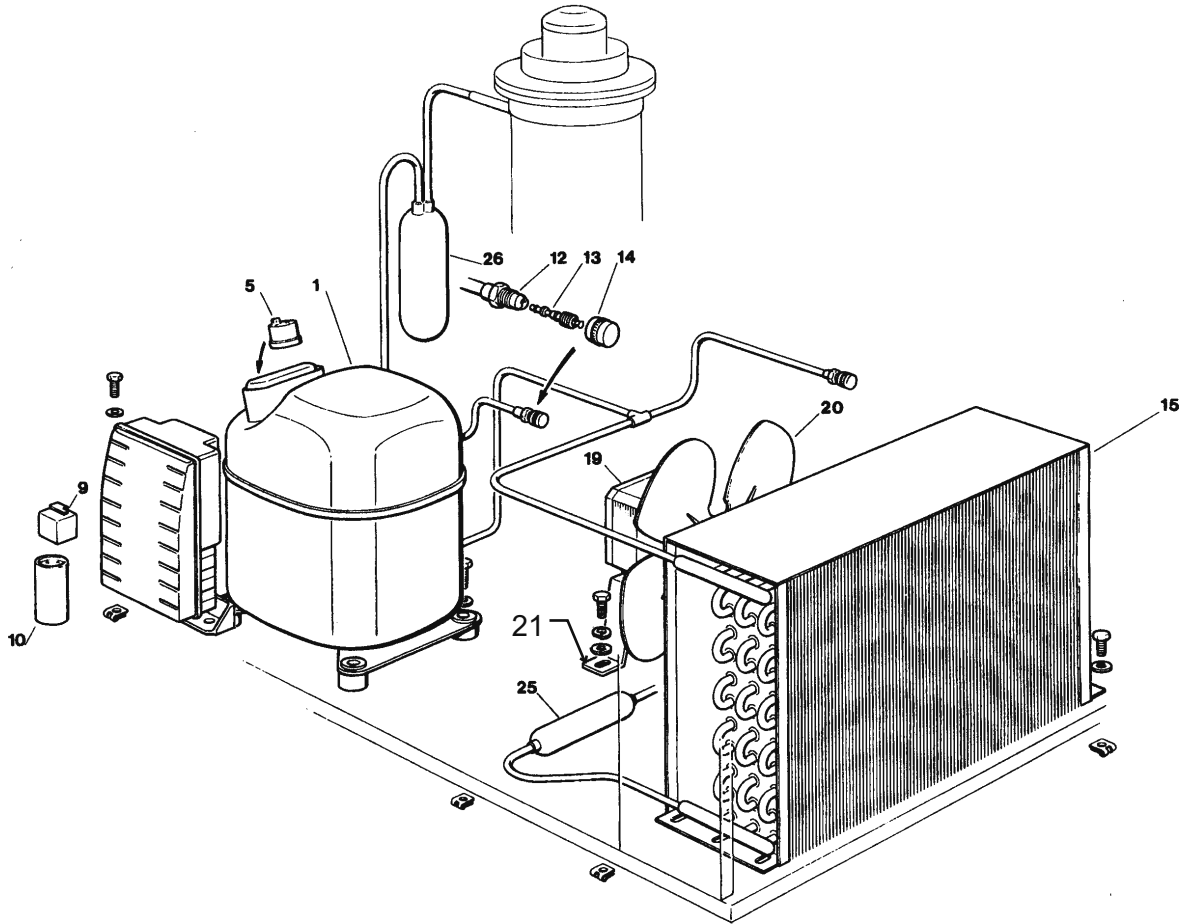

Item Number	Part Number	Description
1	F670101-06	Compressor assy
5	F620058-68	Protector
9	F620057-59	Start Relay
10	F620167-55	Start Capacitor (315 mfd)
12	F650109-00	Valve Body
13	F670012-00	Valve Piston
14	F650106-00	Valve Cap
15	F620439-00	Air Cooled Condenser
19	F620419-03	Fan Motor
20	F620419-33	Fan Blade
21	F620419-61	Fan motor bracket
25	F630003-06	Drier
26	F784469-09	R Suction Line/Accumulator

MDT2 Service Parts

Water and Dispensing

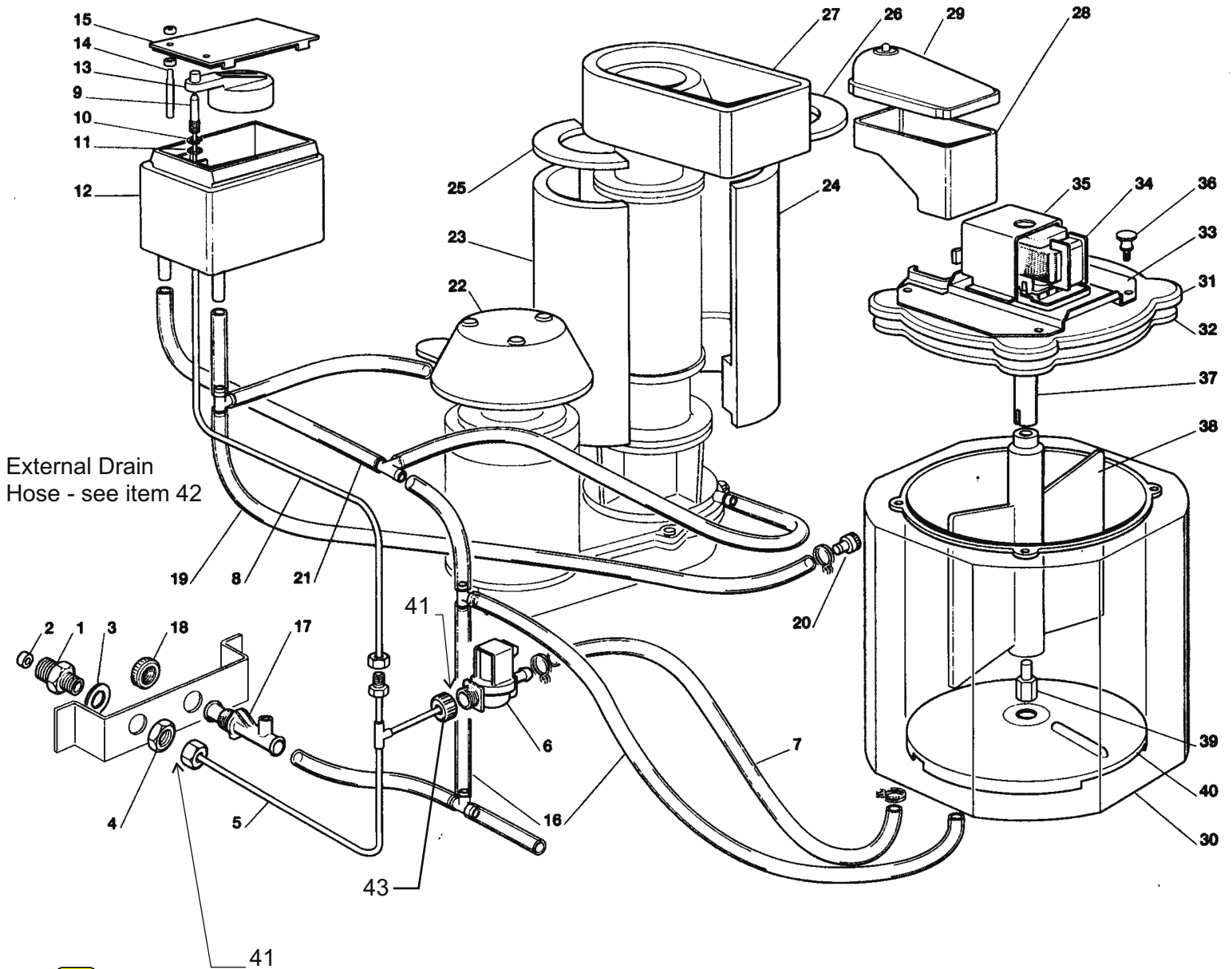

MDT2 Service Parts

Water and Dispensing Part Numbers

Item Number	Part Number	Description	Item Number	Part Number	Description
1	F733205-01	Water Inlet Fitting	34	12-1610-01	Dispensing Motor
2	F650104-00	Strainer	35	F721729-00	Cover, Dispensing Motor
3	F400052-00	Fiber Washer	36	03-0727-10	Screw
4	F400053-00	Nut	37	02-3241-01	Shaft
5	No Number	Copper Water Inlet Tube	38	A37893-001	Ice Agitator
6	F650105-59	Water Inlet Valve	39	02-3033-01	Pin, Vane
7	15-0821-01	Water hose, need 4 units	40	A38272-001	Bin Bottom
8	No Number	Copper Water Inlet Tube	41	F640076-13	Rubber washer
9	F783153-00	Nozzle	42	F060513-01	External drain hose
10	F460038-02	Clip Ring	43	F650752-00	Nut
11	F640100-00	O Ring			
12	F793126-01	Water Reservoir assy			
13	F660585-00	Float Valve assy			
14	F724215-06	Water Level Metal Pin			
15	F660363-00	Water Reservoir Cover			
16	F610194-01	Plastic Tube			
17	F660224-00	Water Drain Fitting			
18	F660535-00	Plastic Ring Nut			
19	F610194-04	Plastic Tube			
20	F650106-00	Valve Cap			
	F650109-00	Valve Body			
21	F610194-02	Plastic Tube			
22	F660670-00	Gear Motor Plastic Cover			
23-24	F060551-04	Insulation			
25-26	F650723-01	Insulation			
27	F650723-00	Spout Insulation			
28	F660695-00	Ice Spout			
29	F660694-00	Ice Spout Cover			
30	A36118-020	Storage Bin			
31	F650747-00	Insulation, Storage Bin Cover			
32	F660662-00	Cover, Storage Bin			
33	A35473 -001	Bracket, Dispensing Motor			

MDT2 Service Parts

Auger Drive and Evaporator

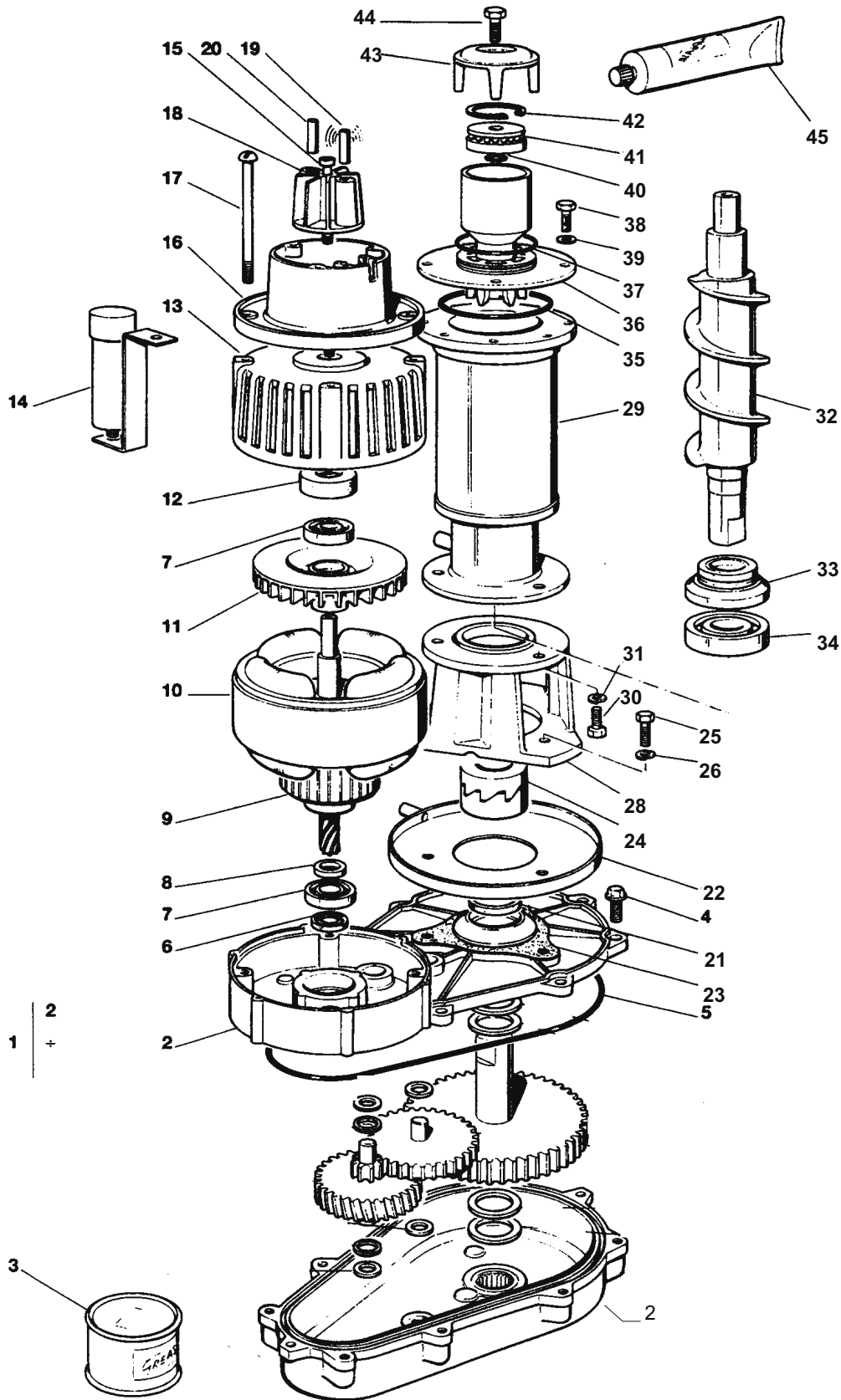

MDT2 Service Parts

Auger Drive and Evaporator Part Numbers

Item Number	Part Number	Description	Item Number	Part Number	Description
1	F794225-14R	Gear Reducer assy	34	02-0417-21	Lower Bearing
2	F001015-01	Gear Case assy	35	F640041-28	O Ring
3	F060294-01	Grease (1 Kg)	36	F060661-00	Ice Breaker
4	03-1251-01	Screw			includes items 37, 41, 42
5	02-1505-00	O Ring	37	F640041-27	O Ring
6	F640083-00	Grease Seal	38	F420019-00	Screw
7	F651056-00	Bearing	39	F440015-04	Washer
8	F441800-09	Trust Washer	40	F640041-25	O Ring
9	F794123-03	R Rotor assy	41	F670041-00	Top Bearing
10	F620394-01	Stator assy	42	F650297-00	Clip Ring
11	F764001-00	Fan Blade	43	F650725-00	Ice Sweep
12	F640095-00	Rubber Insert	44	F420030-00	Screw
13	F794226-01	Drive Motor Cover	45	F263612-00	Water Proof Grease
14	F620520-00	Capacitor			
15	03-1403-77	Screw			
16	F650515-01	Plastic Housing			
17	F423872-01	Screw			
18-19-20	F784476-00	Magneto Holder assy			
21	F640019-01	Grease Seal			
22	F784062-00	Drip Tray			
23	F640060-00	Gasket			
24	F060359-00	Coupling			
25	F421052-00	Screw			
26	F440015-04	Washer			
27	NO NUMBER	Freezer assy			
28	F764010-00	aluminum Adapter			
29	F784541-01	Evaporator			

Evaporator is not foamed, see page 5 item 24 for insulation wrap.

30	F421591-00	Screw
31	F440015-04	Washer
32	F650727-00	Auger
33	02-4599-21	Water Seal

MDT2 Service Parts

Control System

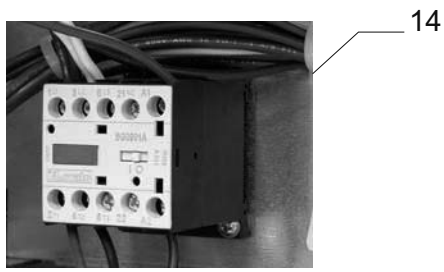

Located under back panel

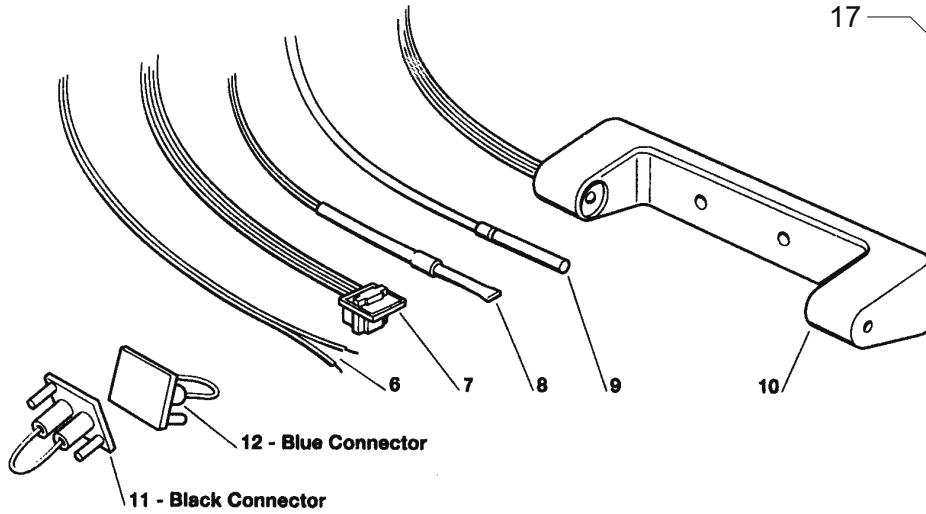
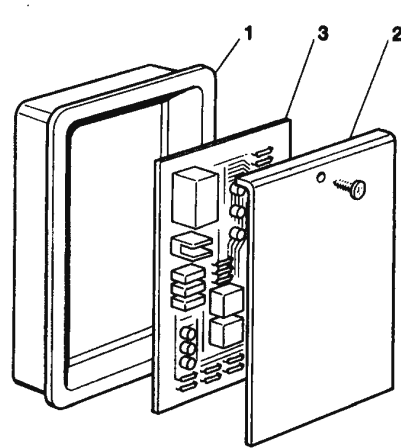
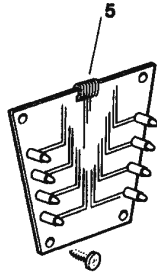

Located under metal divider, see item 8, page 2.

Item Number	Part Number	Description
1	F705231-00	Box only
2	F705332-00	Cover
3	F620448-05	P.C. Board
5	F060613-00	Dispensing selector switch kit to retrofit units with button switches, mfg prior to August 2004, includes items 15 and 16, and items 20 and 21 from page 2.
6	F620404-13	Water Level Sensor
7	F620404-03	Hall Effect Sensor
8	F620404-11	Cond Temp. Sensor
9	F620404-10	Evap Temp. Sensor
10	F650674-01	Ice Level Control assy
11	F620448-03	Dispensing Sensor Tx (Black)
12	F620448-02	Dispensing Sensor rx (Blue)
13	F620448-04	Harness for dispensing sensor
	Not shown	
14	F630119-04	Contactur
15	F620483-03	Dispensing LED board - used on units mfg after August 2004
16	F620483-00	Dispensing selector membrane switch panel - used on units manufactured after August 2004
17	F630107-01	Cable holder

MDT2 Service Parts

Wiring Diagram

WIRING DIAGRAM (MACHINE OPERATING)

BU - BLUE
 W - WHITE
 BK - BLACK
 GR - GREEN
 R - RED
 B - BROWN
 LB - Light Blue

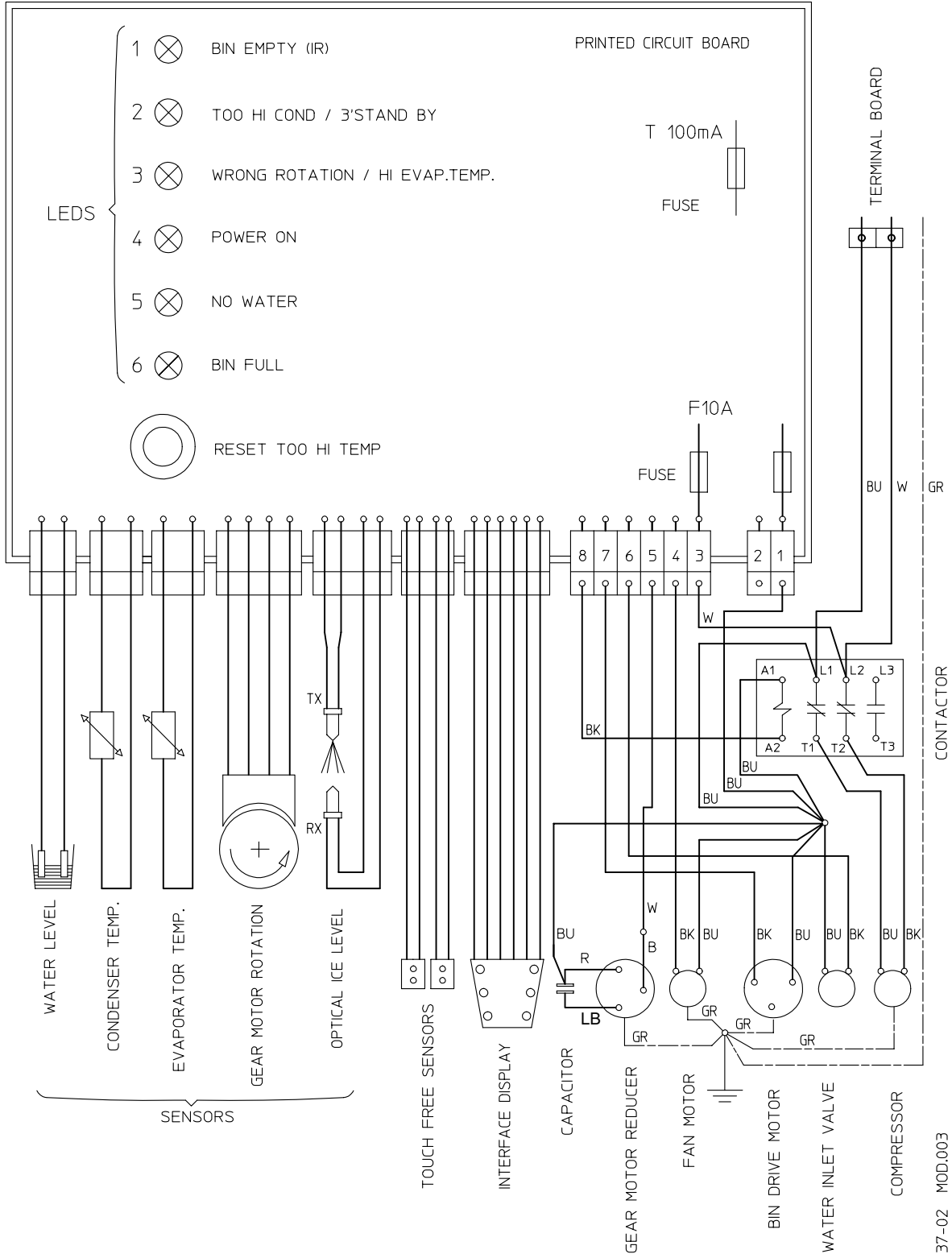

050537-02 MOD.003

MDT2 Service Parts

Wiring Diagram - June 2010 and later

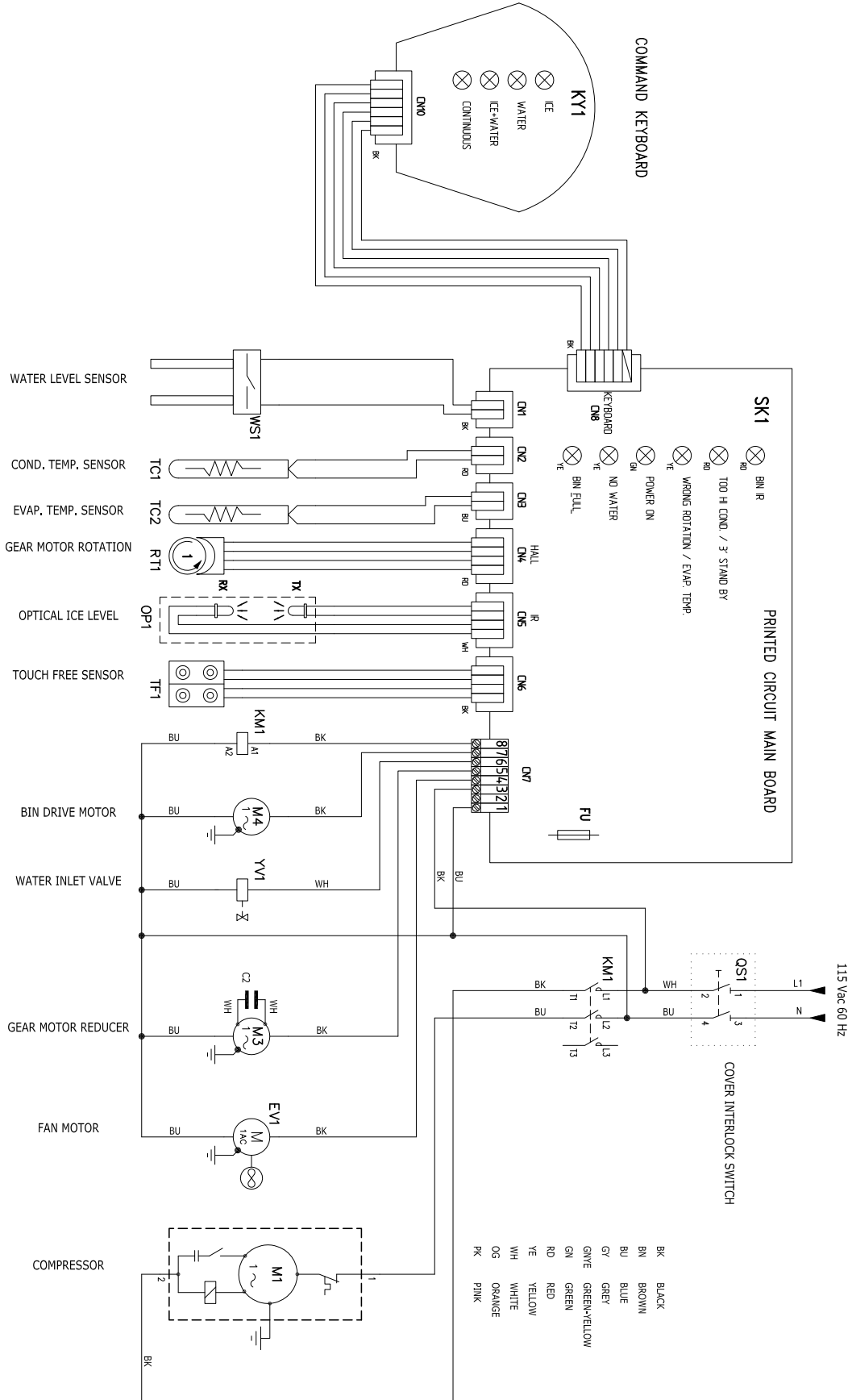

SERVICE BULLETIN

Subject: New Vending Control Panel for MDT2

The dispensing switch panel for the MDT2 has been changed. The label-over-push buttons system has been changed to a membrane switch panel with separate light board.

Part number F060613-00 is a retrofit kit that replaces the existing dispensing PC board, the label and the mounting box with a new assembly.

F620483-00 is the membrane switch panel, and F620483-03 is the LED display board. They can be only be used on units that were originally equipped with membrane switches. Prior models can use the kit.

The ice and water dispensing label F650753-01 has been changed to improve its durability and will remain available.



SERVICE BULLETIN

Subject: MDT2 Front Panel Drain Change

Beginning with serial number 707393-04S, the drain portion of the front panel has been changed. The prior drain was a PVC tube glued to the front panel. The new design uses a screwed together assembly, as shown in the exploded diagram below.

Note: To remove a front panel on the new design, the drain top must be removed so the panel can be separated from the drain fitting.

The part numbers for the new drain system are:

Drain Fitting: F660219-01

O-Ring: F640134-00

Drain Top: F660211-01

