

# MDT3 and MDT4 Service Parts

This parts lists contains part numbers for the service parts available for the MDT3 and MDT4. They have been manufactured in both 60 Hz and 50 Hz models.

The 60 Hz models are:

- MDT3F12-1A or MDT3F12A-1H
- MDT4F12-1A or MDT4F12A-1H

The 50 Hz models are:

- MDT3F12-6A or MDT3F12A-6H
- MDT4F12-6A or MDT4F12A-6H

Always check the model number of the ice machine being serviced to be certain that the parts ordered will be correct.

The service parts for the evaporator changed in April of 2010. A contactor was added in early 2011, the first unit with one was MDT4F12A-1H serial number 11011320013662.

## Table of Contents

Cabinet .....	Page 2
Condensing Components .....	Page 3
Evaporator, Auger, Bearings & Water Seal .....	Page 4
Water And Drain System .....	Page 5
Bin Cover, Dispenser Motor, Electric Eyes .....	Page 6
Prior Gear Reducer and Motor - A31977 type .....	Page 7
Gear Reducer 02-4399-21 or 02-4399-24 or 02-4398-21 .....	Page 8
Control Box .....	Page 9
MDT4 60 Hz Wiring Diagram (w/out contactor) .....	Page 10
MDT3 Wiring Diagram (w/out contactor) .....	Page 11
Schematic Diagram (all w/out contactor) .....	Page 12
MDT4 50 Hz Wiring Diagram (w/out contactor) .....	Page 13
MDT3 or MDT4 Wiring Diagram with Contactor (change in early 2011) .....	Page 14
MDT3 or MDT4 Schematic Diagram with Contactor .....	Page 15

# MDT3 and MDT4 Service Parts

## Cabinet

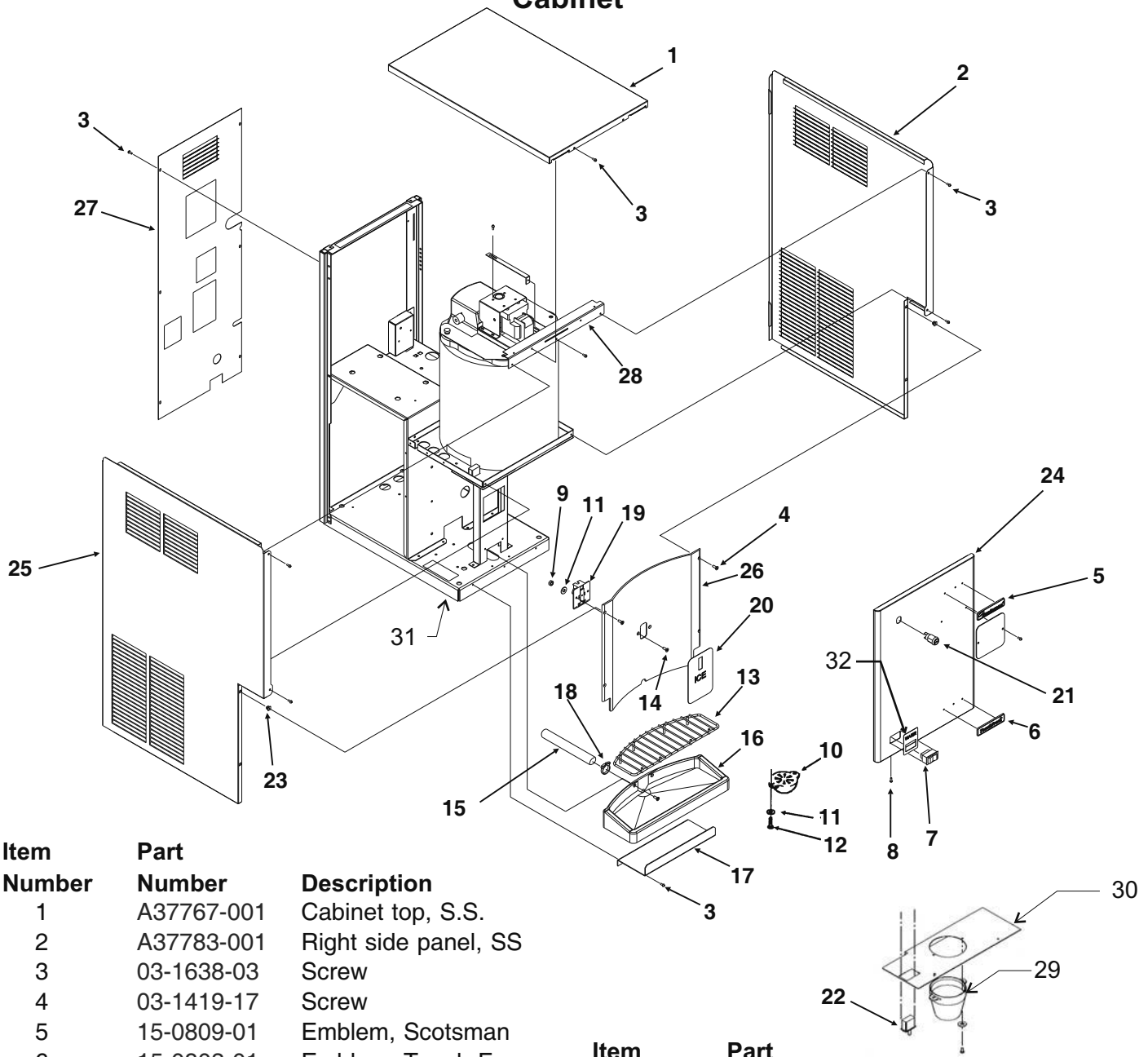

Item Number	Part Number	Description
1	A37767-001	Cabinet top, S.S.
2	A37783-001	Right side panel, SS
3	03-1638-03	Screw
4	03-1419-17	Screw
5	15-0809-01	Emblem, Scotsman
6	15-0803-01	Emblem, Touch-Free
7	12-1377-00	Switch
8	03-1403-15	Screw
9	03-1406-04	Nut
10	02-3944-01	Spout
11	03-1407-03	Washer
12	03-1403-19	Screw
13	02-3302-02	Grill
14	03-1418-30	Machine screw
15	13-0674-07	Tube, order 3 units.
16	02-3402-32	Sink - grey
17	A35875-015	Bracket
18	02-2814-10	Hose clamp
19	12-2551-20	Touch free sensor
20	17-2830-01	Decal

Item Number	Part Number	Description
21	12-2391-01	Lock, Gov't units only
22	12-2501-01	Touch Free disable switch
23	03-3804-01	Screw receptacle
24	A37766-021	Front panel, incl # 5,6,32
	A37766-002	Front panel, Gov't units
25	A37784-001	Left side panel, SS
26	02-3878-31	Splash panel - grey
27	A37875-001	Back panel
28	A37873-001	Support bracket
29	02-3944-01	Clear spout, replaced item 10 in May 2002
30	A36547-001	Mounting plate for spout
31	13-0566-01	Bottom gasket - complete
32	17-2831-01	Water decal

# MDT3 and MDT4 Service Parts

## Condensing Components

### MDT4F12

Item Number	Part Number	Description
1	18-8741-21	60 Hz compressor
	18-8741-26	50 Hz compressor
2	18-8741-27	Overload for 60 Hz
	18-8741-22	Overload for 50 Hz
	18-8741-28	60 Hz relay
	18-8741-23	50 hz relay
3	18-8741-29	Start capacitor for 60 Hz
	18-8741-24	Start capacitor for 50 Hz
4	18-8849-01	60 Hz fan motor
	18-7200-03	50 Hz fan motor
5	18-8858-01	Fan blade for 60 Hz
	18-8743-01	Fan blade for 50 hz
6	A37839-001	Fan shroud for 60 Hz
	A36094-001	Fan shroud for 50 Hz
7	03-1405-40	Screw
7a	03-1407-02	Washer
7b	18-4700-28	Grommet
8	18-0108-41	Sleeve
9	16-0832-21	Access valve
9a	16-0832-03	Core cap
9b	16-0832-02	Stem cap
10	18-0422-00	Fan motor bracket
11	18-8846-01	Condenser
12	02-3319-01	Drier

### MDT3F12

Item Number	Part Number	Description
1	18-8853-21	60 Hz compressor
	18-8853-26	50 Hz compressor
2	18-8853-27	Overload for 60 Hz
	18-8853-22	Overload for 50 Hz
	18-8853-28	60 Hz relay
	18-8853-23	50 hz relay
3	not used	
4	12-1681-23	60 Hz fan motor
	12-1681-04	50 Hz fan motor
5	18-8851-01	Fan blade
6	A37813-001	Fan shroud

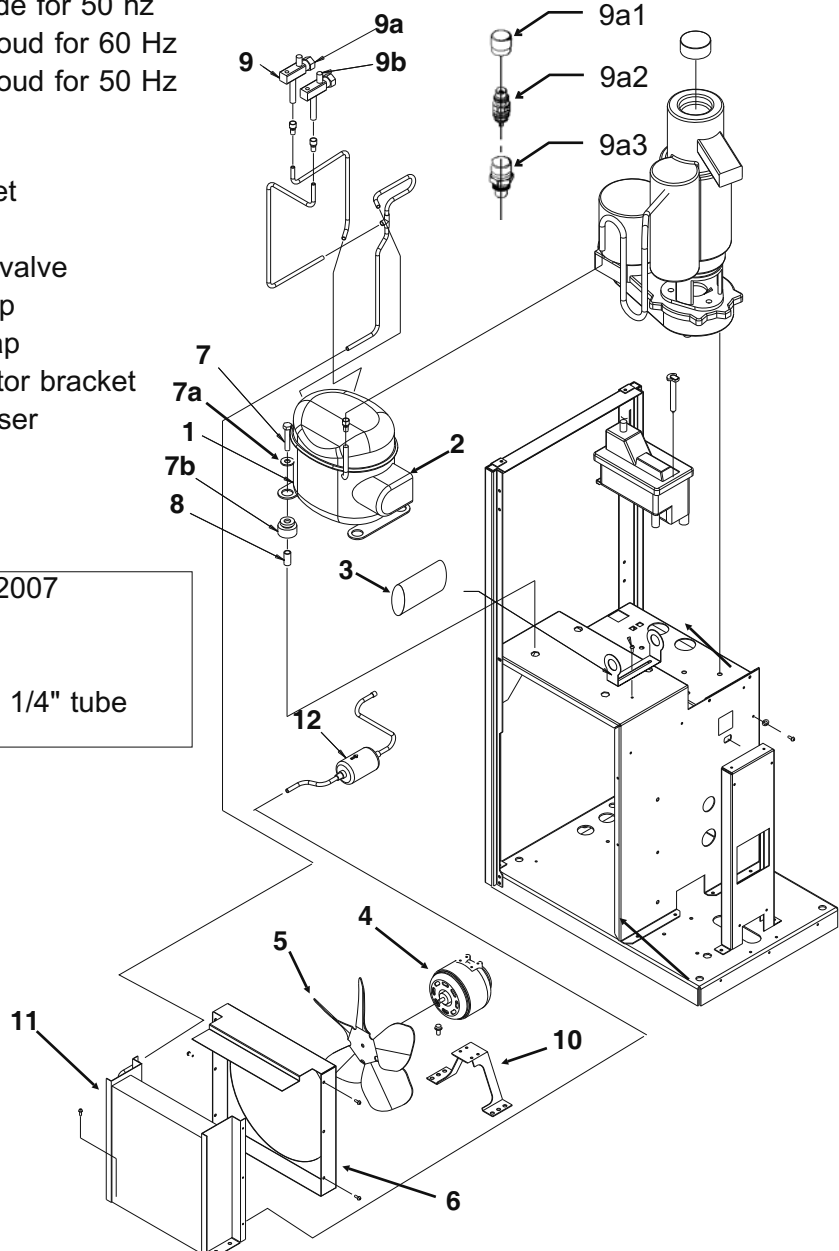

#### Access Valve Change - November 2007

9a1	16-1140-01	Cap
9a2	16-1139-01	Core
9a3	16-1138-01	Seat for 1/4" tube

# MDT3 and MDT4 Service Parts

## Evaporator, Auger, Bearings & Water Seal

ITEM NUMBER	PART NUMBER	DESCRIPTION
1	02-4404-02	Threaded cap - grey
2	03-0758-00	Screw
3	02-4535-01	Top bearing, w/thrust washer - for updated units*
4	02-4575-21	Breaker kit, includes items 1, 3, 4a, 4b, 7 & 7a*
4a	13-0617-16	O-Ring (inside)
4b	13-0617-37	O-Ring, outside of breaker
5	02-4600-20	Auger - for updated units*
6	A36081-020	Evaporator
7	03-1417-07	Washer
7a	03-1403-46	Screw
8	02-4599-21	Water Seal
9	02-0417-21	Lower Bearing
10	03-1505-00	Gasket
11	08-0595-01	Adapter
12	03-1405-38	Cap Screw (3)
13	03-1420-01	Cap screw
14	03-1410-04	Washer (3)
15	A29915-002	Spline Coupling
16	02-4578-02	Auger and bearing kit

Includes items 1, 2, 4, 4a, 4b, 5, 7, 7a, 8, and 9

17 19-0662-02 Top bearing grease, 13 oz tube

Note: Use about 1 oz per bearing. Lightly coat bearing surfaces, thoroughly grease thrust portion of bearing (horizontal needles).

\* Updated units use listed auger and top breaker and bearing.

Update availability began Feb. 2010. Updated units and later production units have grey cap to indicate use of this type of top bearing and auger. Non-updated units or units with white or brass cap require auger kit item 16 when replacing top bearing or auger.

Production with listed bearing and auger began in April 2010 and have a grey cap. Prior top bearing and auger are no longer available.

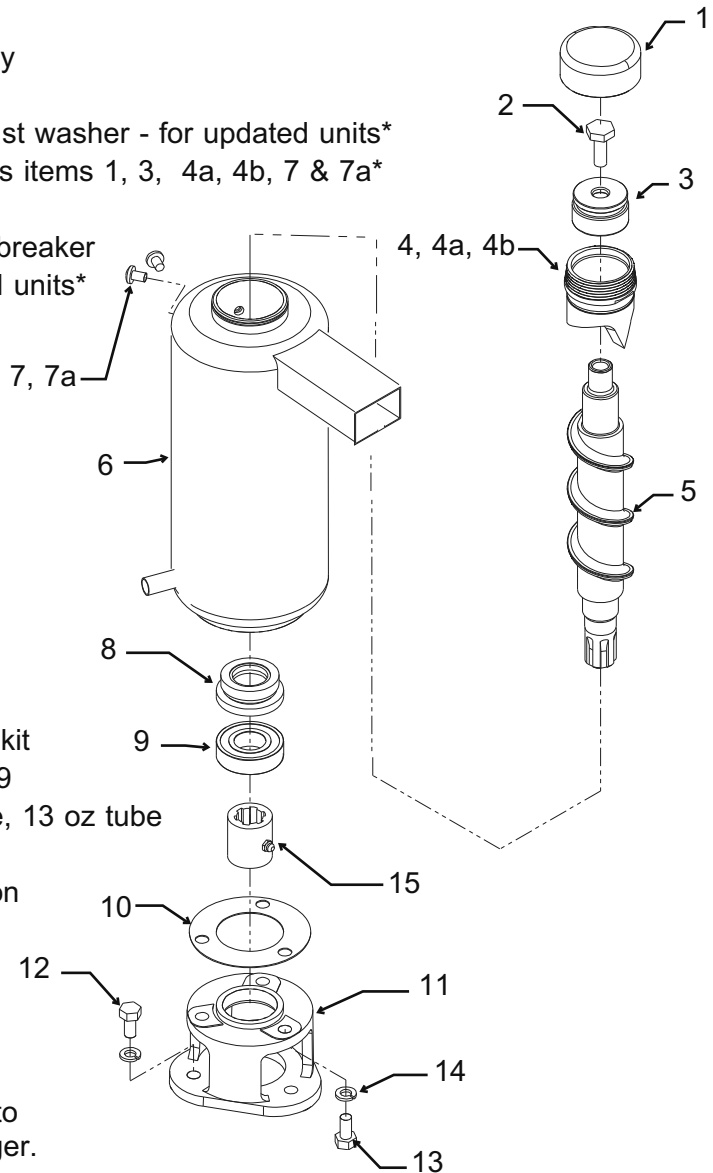

# MDT3 and MDT4 Service Parts

## Water And Drain System

Item Number	Part Number	Description
1	A37893-001	Vane Assembly
2	A38272-001	Bin Bottom Assy
3	02-3033-01	Hub Assembly
4	03-1409-22	Fiber Washer
5	A36118-020	Storage Bin
6	13-0895-01	Inlet water line requires 26"
7	03-1394-00	Pal Nut
8	12-1434-04	Water valve (60 Hz)
	12-1434-05	Water valve (50 Hz)
9	16-0869-01	Barbed adapter
10	02-4200-01	Preformed tube
11	A33101-022	Water sensor
12	02-3402-32	Sink
13	02-3302-02	Grill for sink
14	13-0674-07	Tube, requires 12"
15	02-2814-10	Clamps
16	13-0674-09	Tube, overflow to drain, requires 12"
16a		Bin drain, 11"
16b		Drain, 9"
17	02-2814-08	Clamp
18	02-2814-07	Clamp
19	02-3371-01	Reservoir Assy
20	A36402-001	Reservoir Bracket
21	02-3371-02	Float and arm
21a	02-3266-03	Plunger/seat
22	03-1409-22	Washer
23	03-1645-01	Hex Cap Screw
24	13-0674-06	Tube (to evap.)
25	A21433-000	Inlet fitting
26	16-0870-01	NPT to compr. fitting
27	16-0871-01	Brass insert
28	16-0670-01	Tee

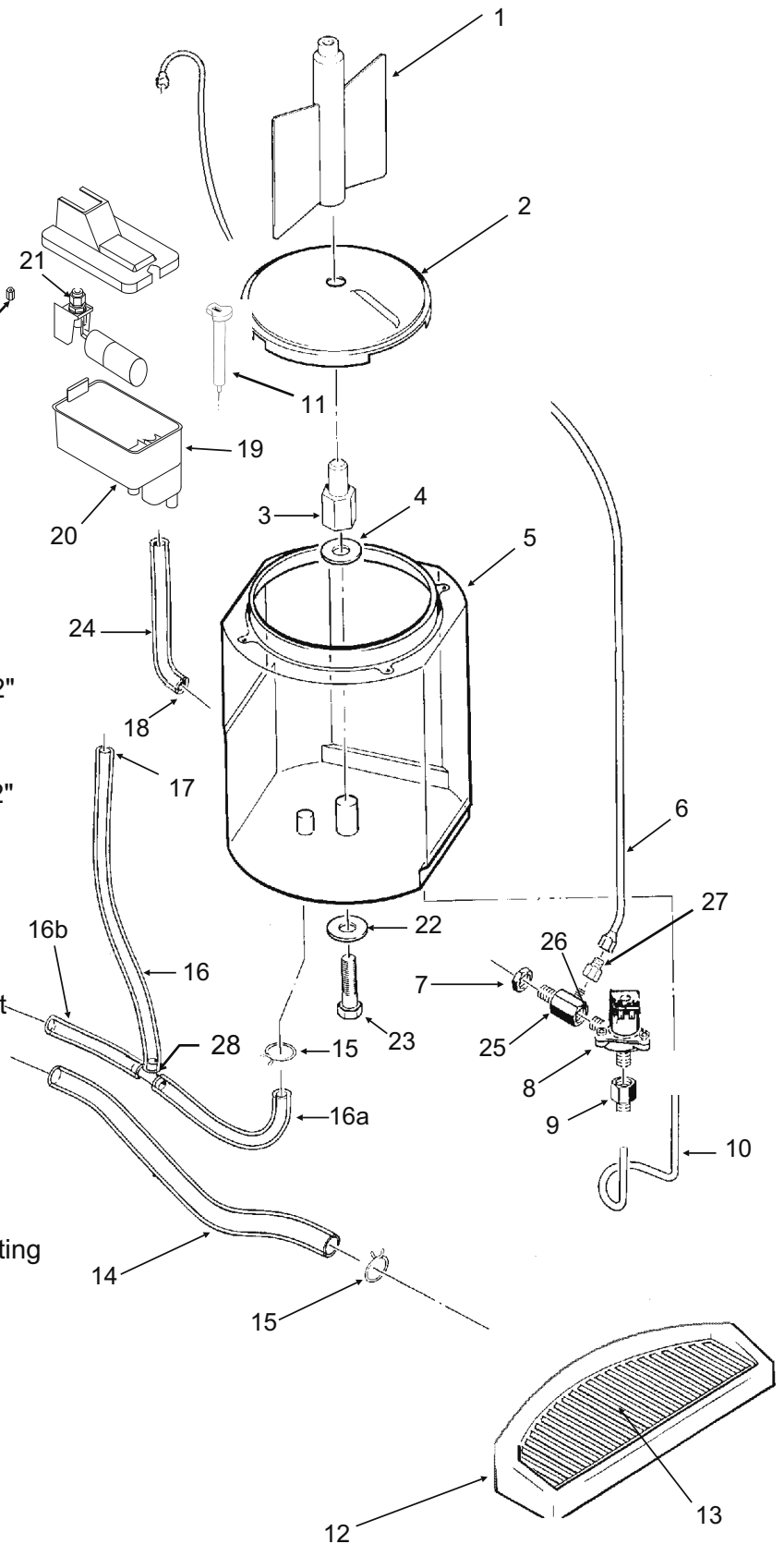

# MDT3 and MDT4 Service Parts

## Bin Cover, Dispenser Motor, Electric Eyes

Item Number	Part Number	Description
1	03-1403-15	Screw
2	03-1531-01	Screw
3	A35474-001	Motor Mtg. Bracket
4	02-3238-01	Bushing
5	03-0727-10	Thumbscrew
6	13-0866-01	Grommet
7	A37710-021	Electric eye set
8	02-3237-01	Bin top
9	02-3239-01	Nut
10	02-3241-01	Shaft
11	12-1610-01	Motor & gears 60 Hz
11	12-1610-06	Motor & gears 50 Hz
12	02-1801-02	Strap
	A35483-021	Complete assembly 60 Hz (except items 5 and 7)
	A35483-026	Complete assembly 50 Hz (except items 5 and 7)

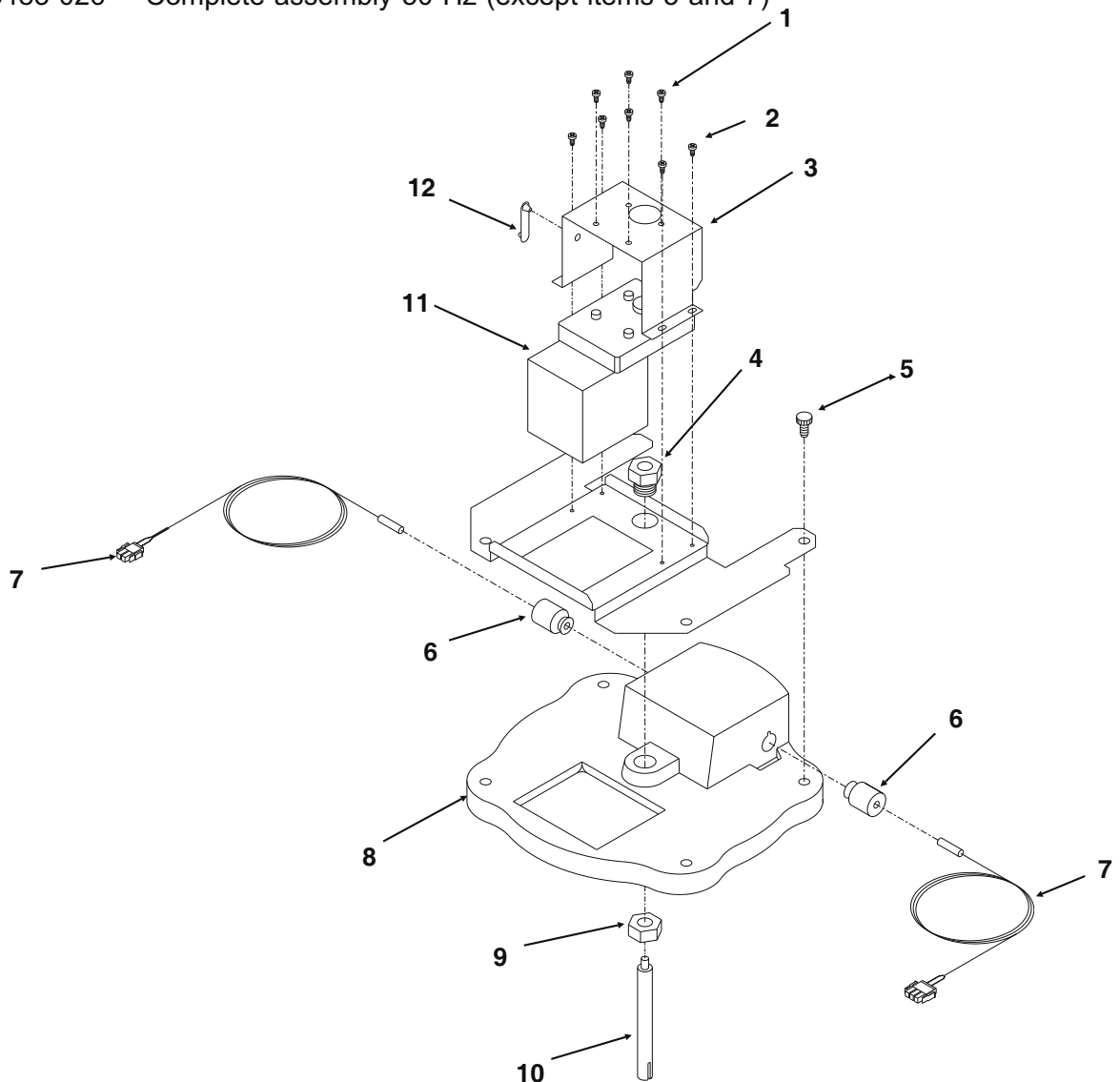

# MDT3 and MDT4 Service Parts

## Prior Gear Reducer and Motor - A31977 type

Item Number	Part Number	Description
1.	12-2059-01	Switch
2.	none, part of item 3	
3.	A27494-001	Centrifugal Sw. Kit
4.	03-1403-77	Screw
5.	A30579-001	Shaft and Actuator
6.	03-1408-36	Washer
7.	02-1503-00	Grease seal
8.	03-1408-21	Washer
9.	03-1408-04	Washer
10.	02-2445-01	Output shaft
11.	03-1515-03	Retaining ring
12.	03-1602-01	Woodruff Key
13.	02-2444-01	Output gear
14.	02-1505-00	O-ring
15.	03-0774-11	Roll pin
16.	A28166-001	Gear Case
17.	03-1408-39	Washer
18.	03-1408-40	Washer shim
19.	02-2439-01	2nd gear & third pinion
20.	03-1408-41	Washer
21.	03-1408-38	Washer
22.	02-2438-01	1st gear & 2nd pinion
23.	A28165-021	Gear box cover
24.	02-3969-20	Grease seal
25.	02-1501-00	Bearing

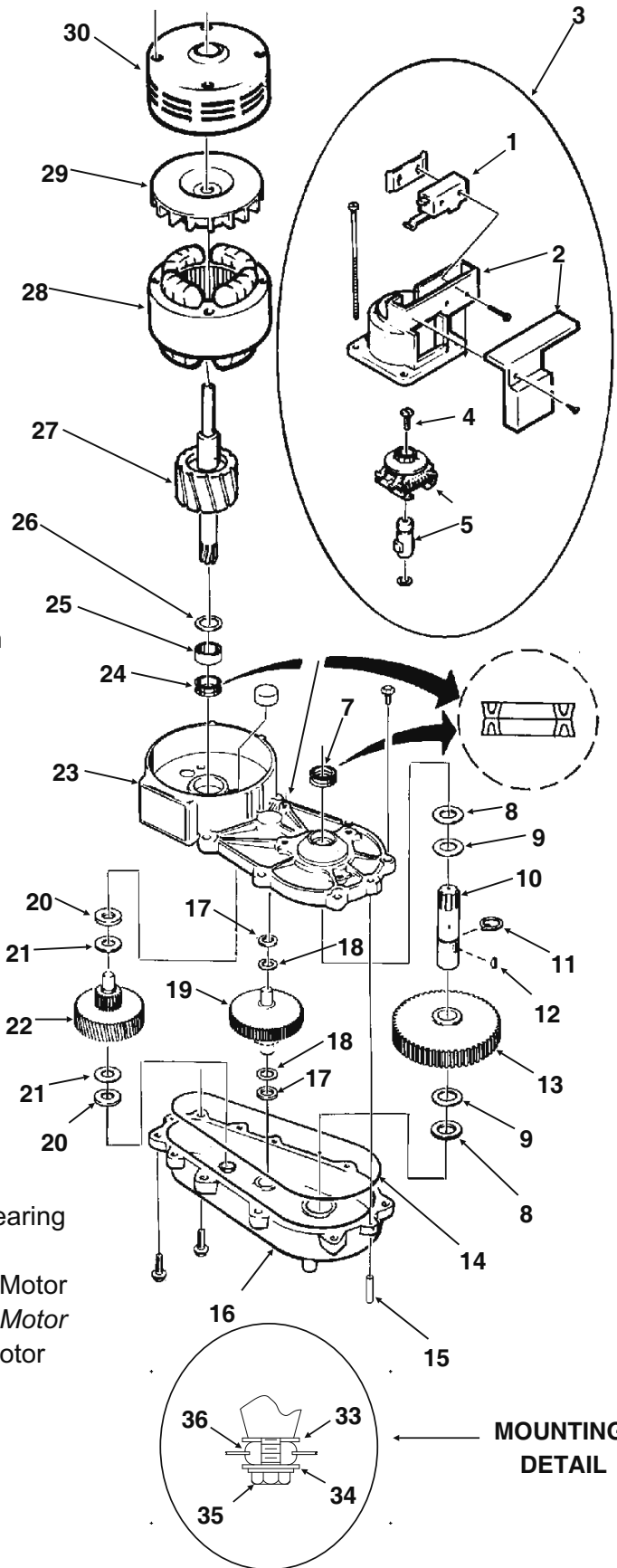

26.	03-1408-08	Washer
27.	A37707-021	60 Hz motor kit*
28.	A38501-001	50 Hz motor kit*
29.	A28168-001	Fan
30.	A38487-001	Motor Housing with bearing
31.	A32379-027	Oil
32.	02-4399-21	Complete 60 Hz Gear Motor
	02-4399-24	Complete 50 Hz Gear Motor
	02-4398-21	Gear reducer kit, no motor
33.	A24295-001	Spacer
34.	03-1408-02	Washer
35.	03-1405-45	Screw
36.	13-0639-00	Grommet

\* motor kit includes items 25, 26, 29 and 30.

# MDT3 and MDT4 Service Parts

## Gear Reducer 02-4399-21 or 02-4399-24 or 02-4398-21

ITEM NUMBER	PART NUMBER	DESCRIPTION
1.	12-2059-01	Switch
2.	A27494-001	Centrifugal Sw. Kit
3.	03-1403-77	Screw
4.	A30579-001	Shaft and Actuator
5.	part of item 2	
6.	03-1408-36	Washer
7.	02-1503-00	Grease seal
8.	13-0947-01	Gasket
9.	03-1408-39	Washer
10.	03-1408-40	Washer shim
11.	02-2439-01	2nd gear and third pinion
12.	03-1408-41	Washer
13.	03-1408-38	Washer
14.	02-2438-01	1st gear & second pinion
15.	02-3969-20	Grease seal
16.	02-1501-00	Bearing
17.	03-1408-08	Washer
18.	A37707-021	60 Hz motor kit*
	A38501-001	50 Hz motor kit*
19.	A28168-001	Fan
20.	A38487-001	Motor Housing w/ bearing
21.	A32379-027	Oil
22.	02-4399-21	Complete 60 Hz Gear Motor Assembly with motor
	02-4399-24	Complete 50 Hz Gear Motor Assembly with motor
	02-4398-21	Gear reducer kit, no motor
23.	A24295-001	Spacer
24.	03-1408-02	Washer
25.	03-1405-45	Screw
26.	13-0639-00	Grommet
27.	13-0941-01	Water shed

\* motor kit includes items 16, 17, 19, 20  
 Note: Wire termination on replacement motor varies from original equipment.

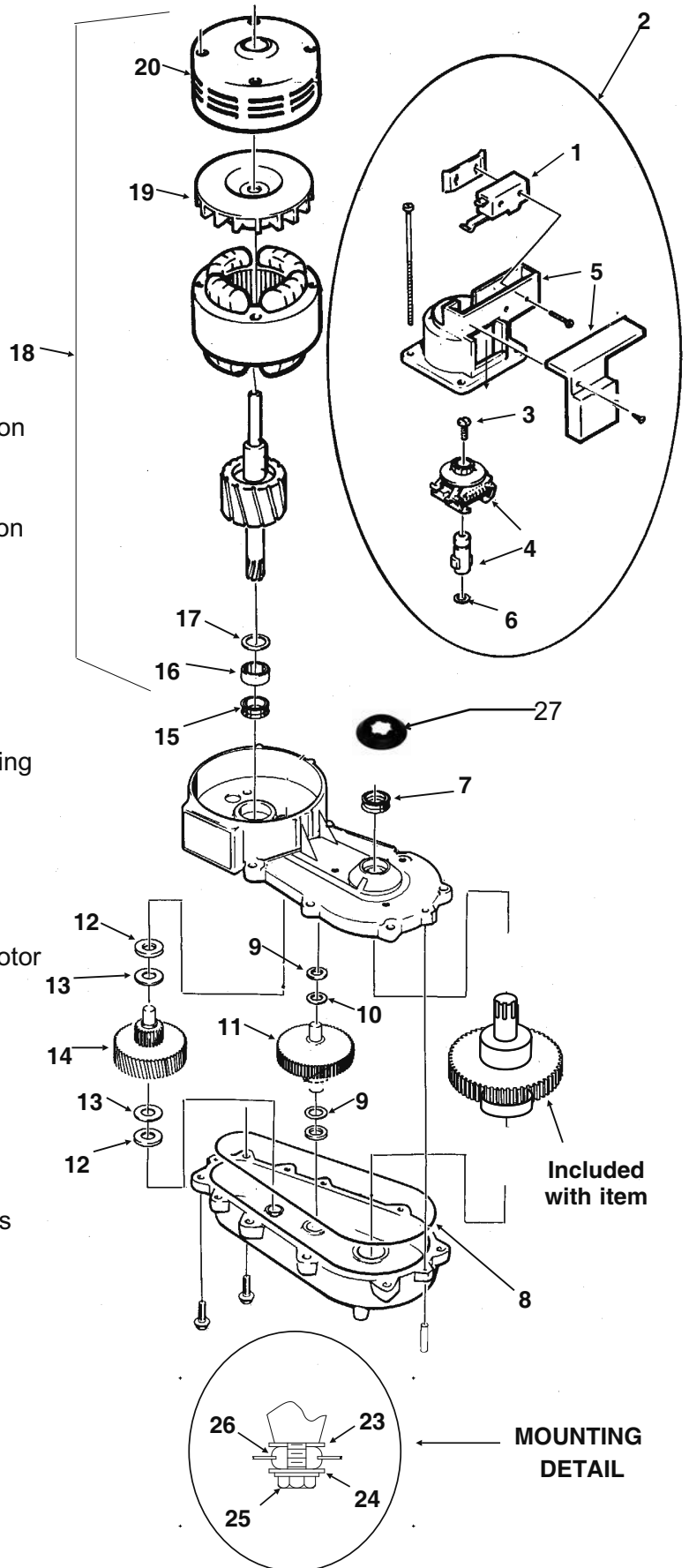



# MDT3 and MDT4 Service Parts Control Box

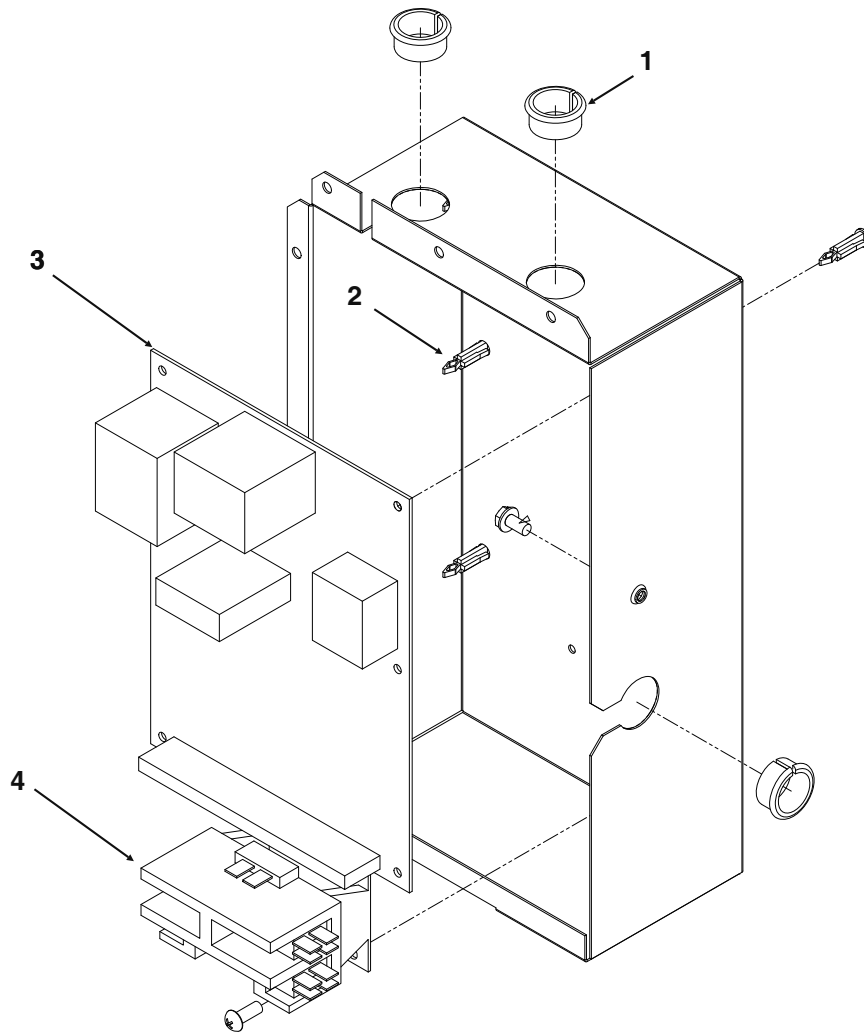

Item Number	Part Number	Description
1	12-1213-10	Snap bushing
2	12-2499-01	Stand off
3	12-2843-21	Circuit board for 115/60/1
	12-2843-26	Circuit board for 220/50/1
4*	12-2469-03	Contactor, 115/60/1
	12-2469-02	Contactor, for 50 Hz model
Not shown:		
5	12-3042-01	Wire harness for 60 Hz model w/contactor
	12-3042-02	Wire harness for 50 Hz model w/contactor

\* Contactor added after MDT4F12A-1H 11011320013662.

# MDT3 and MDT4 Service Parts

## MDT4 60 Hz Wiring Diagram (w/out contactor)

A36522-001

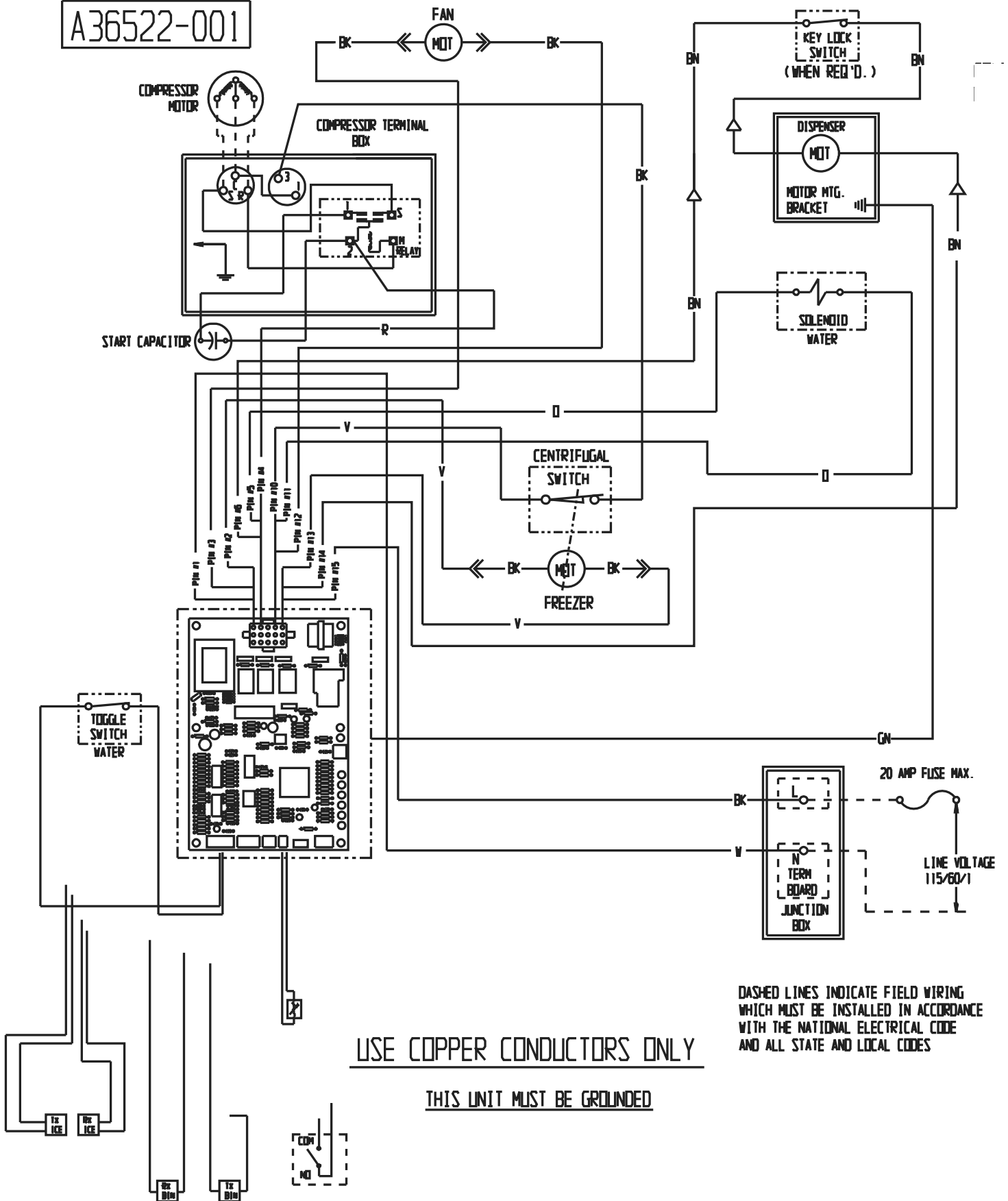

USE COPPER CONDUCTORS ONLY

THIS UNIT MUST BE GROUNDED

DASHED LINES INDICATE FIELD WIRING WHICH MUST BE INSTALLED IN ACCORDANCE WITH THE NATIONAL ELECTRICAL CODE AND ALL STATE AND LOCAL CODES

# MDT3 and MDT4 Service Parts

## MDT3 Wiring Diagram (w/out contactor)

△ = WIRE NUT

17-2835-01

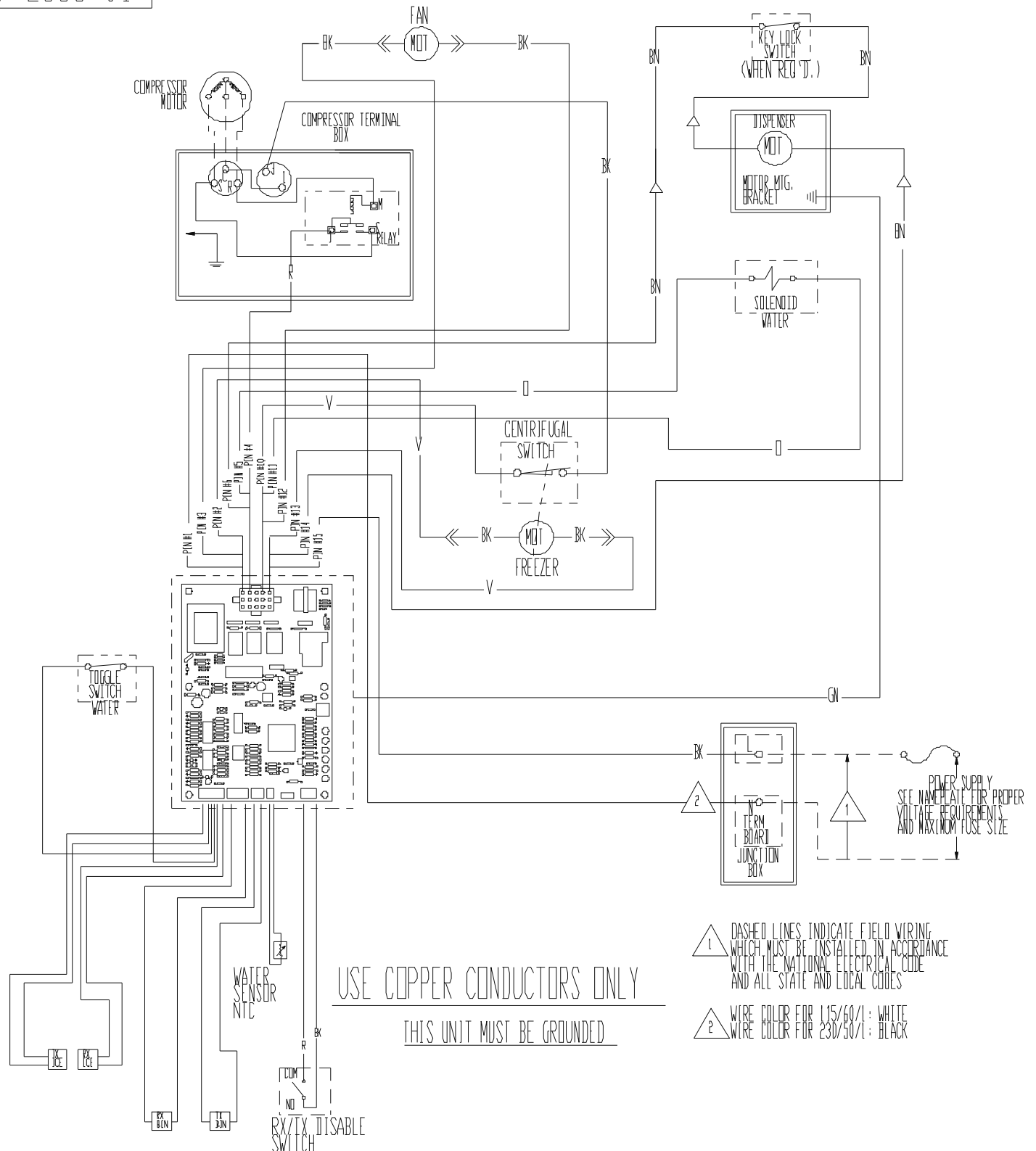

# MDT3 and MDT4 Service Parts Schematic Diagram (all w/out contactor)

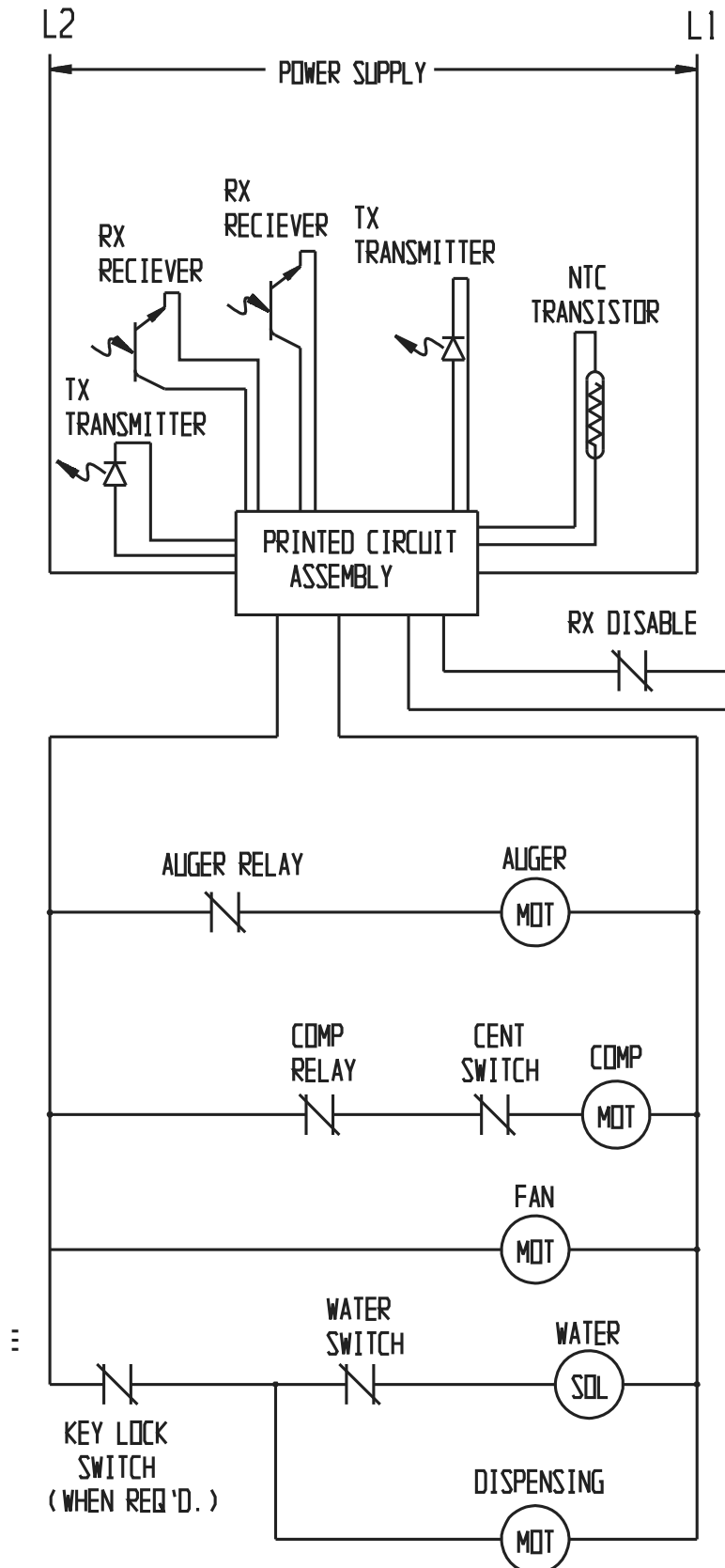

Controls shown in the ice making mode with all dispensing systems in operation.

# MDT3 and MDT4 Service Parts

## MDT4 50 Hz Wiring Diagram (w/out contactor)

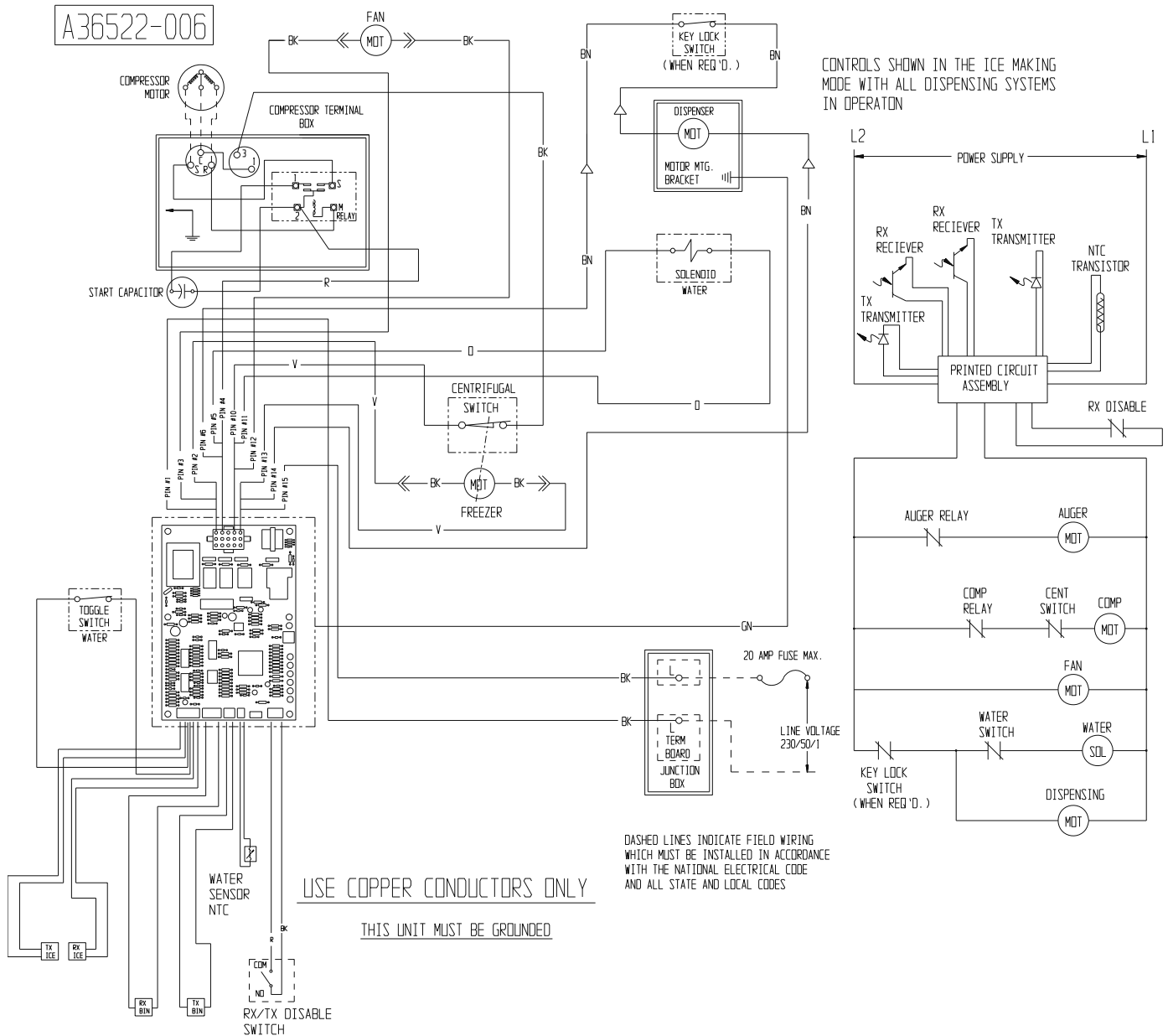

# MDT3 and MDT4 Service Parts

## MDT3 or MDT4 Wiring Diagram with Contactor (change in early 2011)

17-3349-01

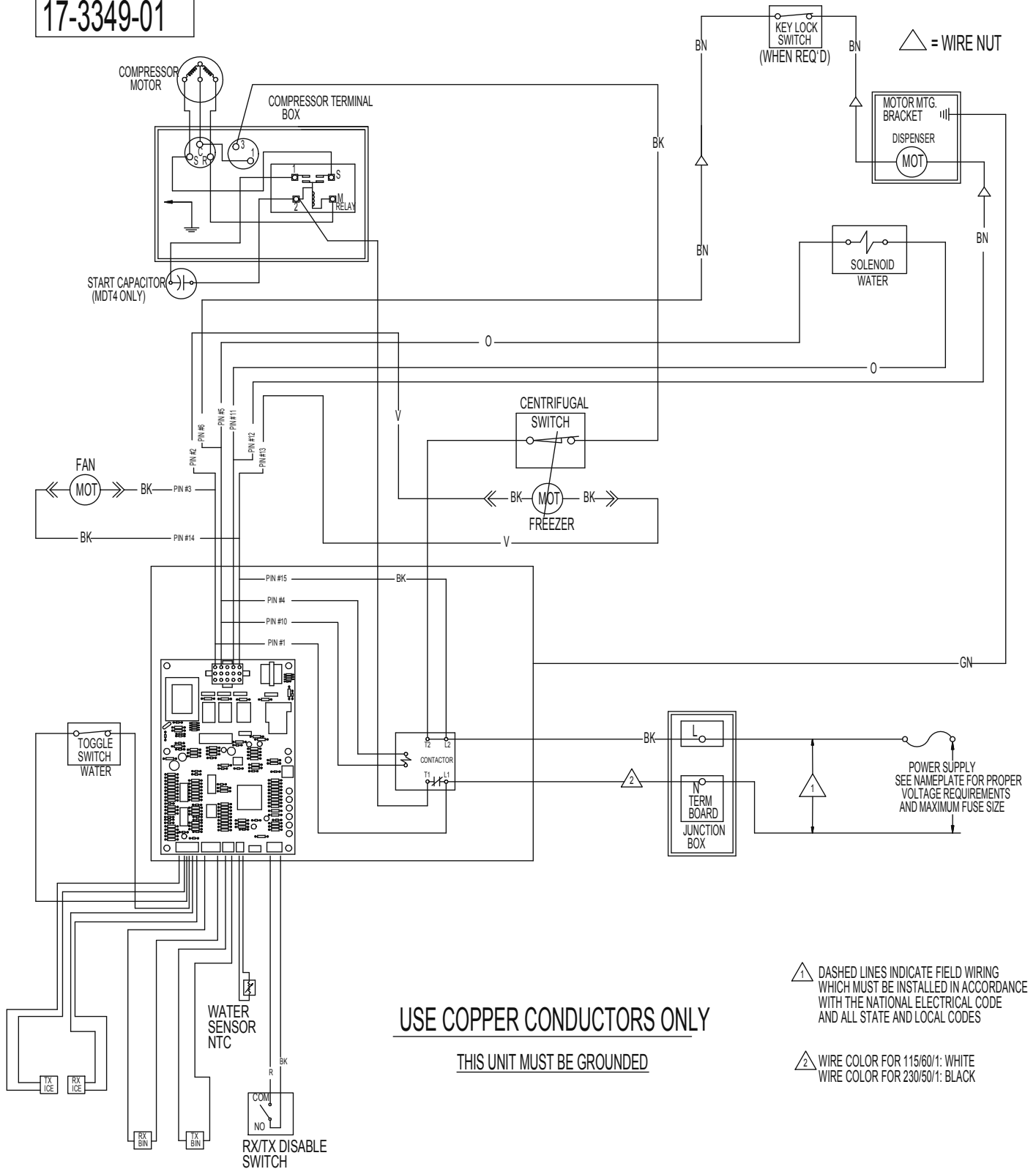

**USE COPPER CONDUCTORS ONLY**

**THIS UNIT MUST BE GROUNDED**

△ DASHED LINES INDICATE FIELD WIRING WHICH MUST BE INSTALLED IN ACCORDANCE WITH THE NATIONAL ELECTRICAL CODE AND ALL STATE AND LOCAL CODES

△ WIRE COLOR FOR 115/60/1: WHITE  
WIRE COLOR FOR 230/50/1: BLACK

# MDT3 and MDT4 Service Parts

## MDT3 or MDT4 Schematic Diagram with Contactor

CONTROLS SHOWN IN THE ICE MAKING  
MODE WITH ALL DISPENSING SYSTEMS  
IN OPERATON

