

# MDT6N SERVICE PARTS

This parts list contains the service parts and wiring diagrams for this model. Check the model number of the machine needing parts to be sure that this is the correct parts list.

There have been several series changes. The A series water cooled condenser is different from the B thru J series.

The J series compressor is different from the A - H series.

**Note: The liquid line filter drier listed in this parts list is designed for this refrigeration system.**

**Premature failure may result if the wrong drier is used.**

## TABLE OF CONTENTS

Cabinet . . . . .	PAGE 2
Hopper . . . . .	PAGE 3
Sink . . . . .	PAGE 4
Ice Chute and Dispensing . . . . .	PAGE 5
Air Cooled Refrigeration . . . . .	PAGE 6
Water Cooled Refrigeration . . . . .	PAGE 7
Water System . . . . .	PAGE 8
Evaporator . . . . .	PAGE 9
Gearmotor . . . . .	PAGE 10
Control Box . . . . .	PAGE 11
Wiring Diagram . . . . .	PAGE 12
Schematic Diagram . . . . .	PAGE 13

# MDT6N SERVICE PARTS

## Cabinet

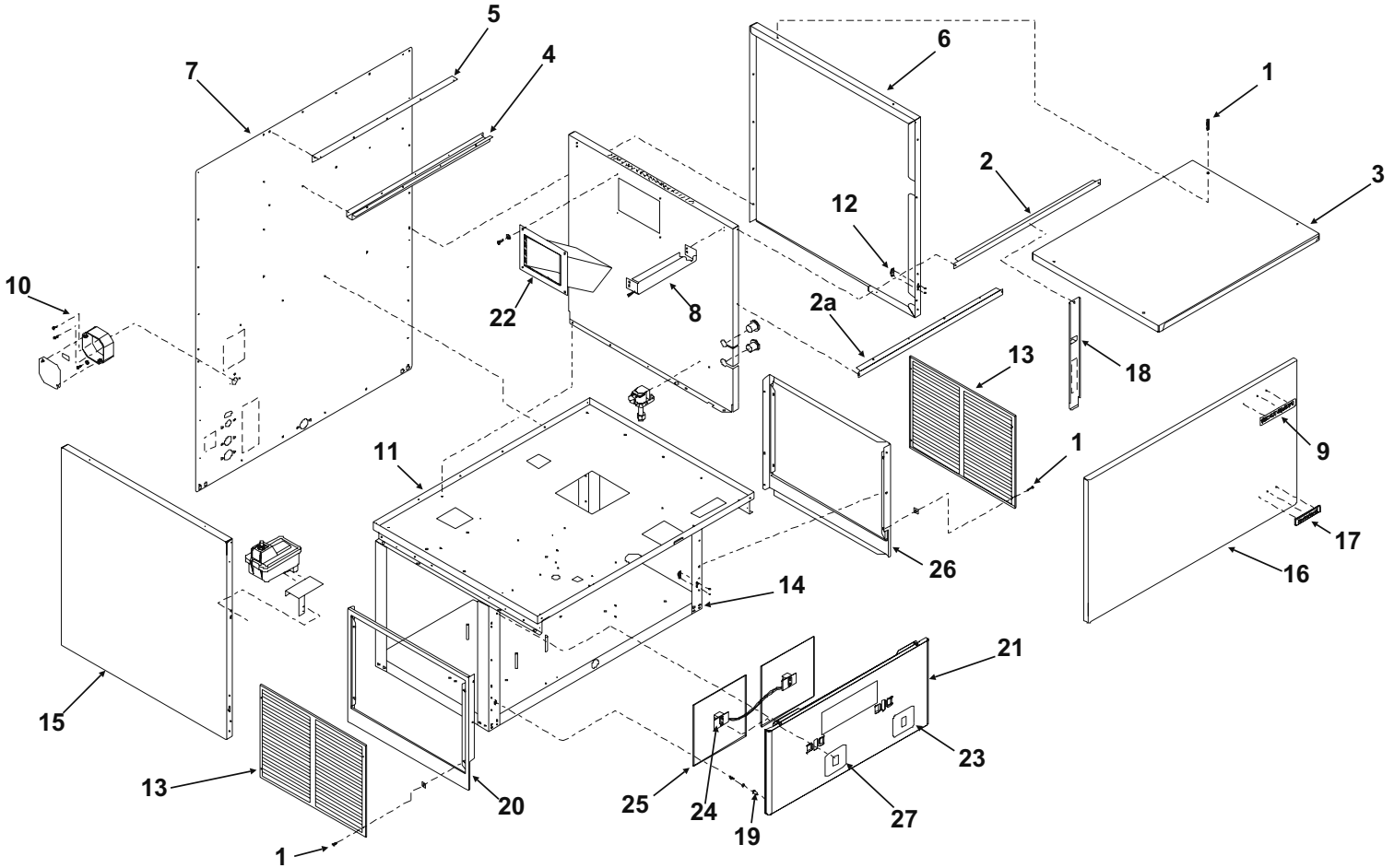

ITEM NUMBER	PART NUMBER	DESCRIPTION
1	03-1419-22	S.S. Screw
2	A34563-001	Upper Brace
2a	A34562-001	Upper brace
3	A37806-001	Top panel, stainless
4	A34625-015	Bin support
5	A33270-015	Bin support brace
6	A37809-021	Rt. side upper panel
7	A33276-002	Back panel, stainless
8	A33269-015	Upper brace
9	15-0808-01	Emblem
10	03-1531-01	Screw
11	A33285-015	Upper Plate
12	03-1733-02	Retainer for ball stud
13	A33281-002	Service Panel, stainless
14	A33280-001	Lower frame assy
15	A37808-021	Left side panel, upper
16	A37771-021	Upper front panel, s s
	A37771-002	Front pnl, ss, gov't mod
17	15-0803-01	Emblem, Touch Free
18	A35305-001	Bracket
19	03-1733-01	Ball stud
	03-1733-02	Catch for stud (riveted to panel)
20	A33284-002	Lower left side panel
21	A37782-021	Splash panel
22	02-2973-02	Ice chute
23	17-2830-01	Touch free ice label
24	12-2495-21	Sensor set
25	19-0644-01	Insulation pad
26	A33284-004	Rt. side lower panel
27	17-2830-02	Touch free water label

# MDT6N SERVICE PARTS

## Hopper

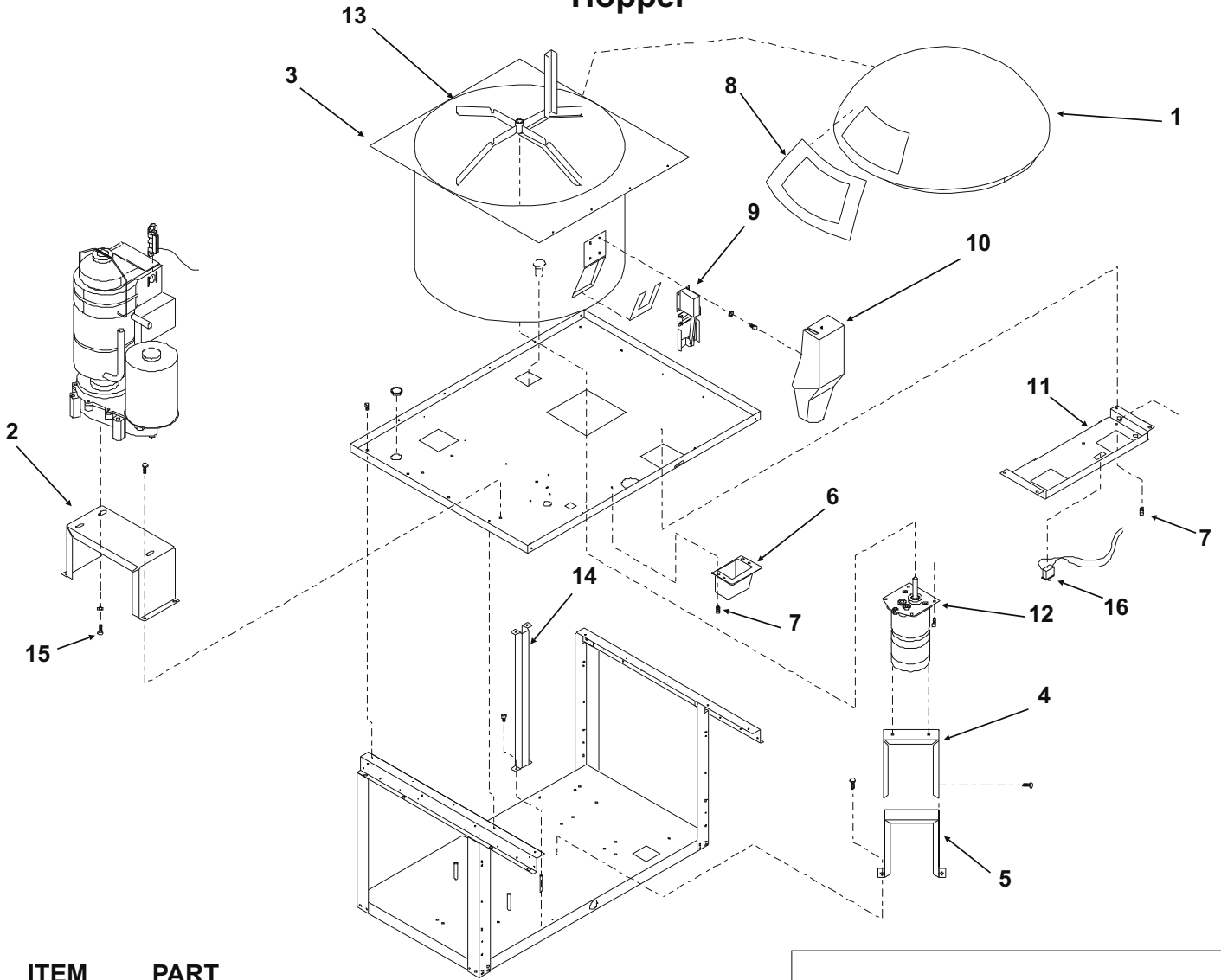

ITEM NUMBER	PART NUMBER	DESCRIPTION
1	A34957-001	Ice bin cover
2	A33287-015	Evap. support bracket
3	A34015-001	Ice Storage Bin
4	A34508-015	Agit mtr support, upper
5	A34509-015	Agit mtr support, lower
6	A34578-002	Water Chute, not used after 9/01
7	03-1531-01	Screw
8	13-0875-01	Grommet
9	02-3233-01	Door gasket
10	A35321-001	Ice chute before 9/01
	A35321-004	Ice chute after 9/01
11	A37883-001	Bracket
12	12-2368-01	Dispense motor assembly
	A32672-001	Heater for dispense gear motor
13	02-3116-01	Agitator
14	A33271-015	Brace
15	03-1405-17	Screw
16	12-2501-01	Touch free disable switch
17	02-3909-01	Spout
18	12-2391-01	Government switch
19	A38105-001	Chute extension, use began 12/01

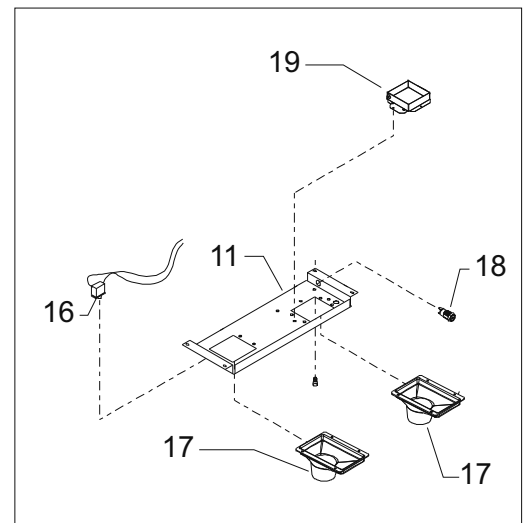

Spout Change Sept. 2001

Kit A38106-001 includes items 10, 11, 19, & two 17s

# MDT6N SERVICE PARTS

## Sink

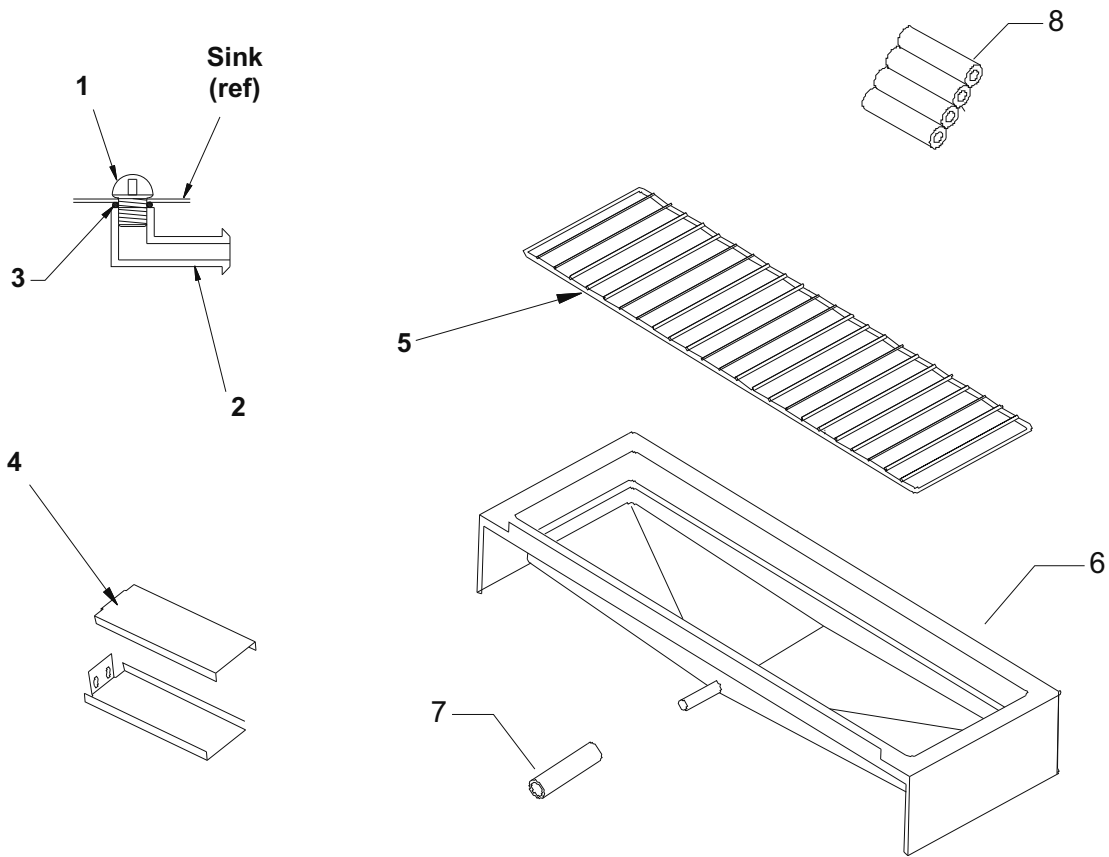

ITEM NUMBER	PART NUMBER	DESCRIPTION
1	02-2809-01	Drain top
2	02-1742-00	Drain btm
3	13-0617-11	O-ring
4	A34401-016	Right sink support
	A34401-015	Sink support left
	03-1645-01	Screw 1/4 20 x 1/2"
5	02-2582-01	Grill
6	A31047-032	Sink assembly, includes items 1, 2 and 3.
7	13-0674-07	Tube, need 33"
8	A32235-001	Hold down for Gov. units

# MDT6N SERVICE PARTS

## Ice Chute and Dispensing

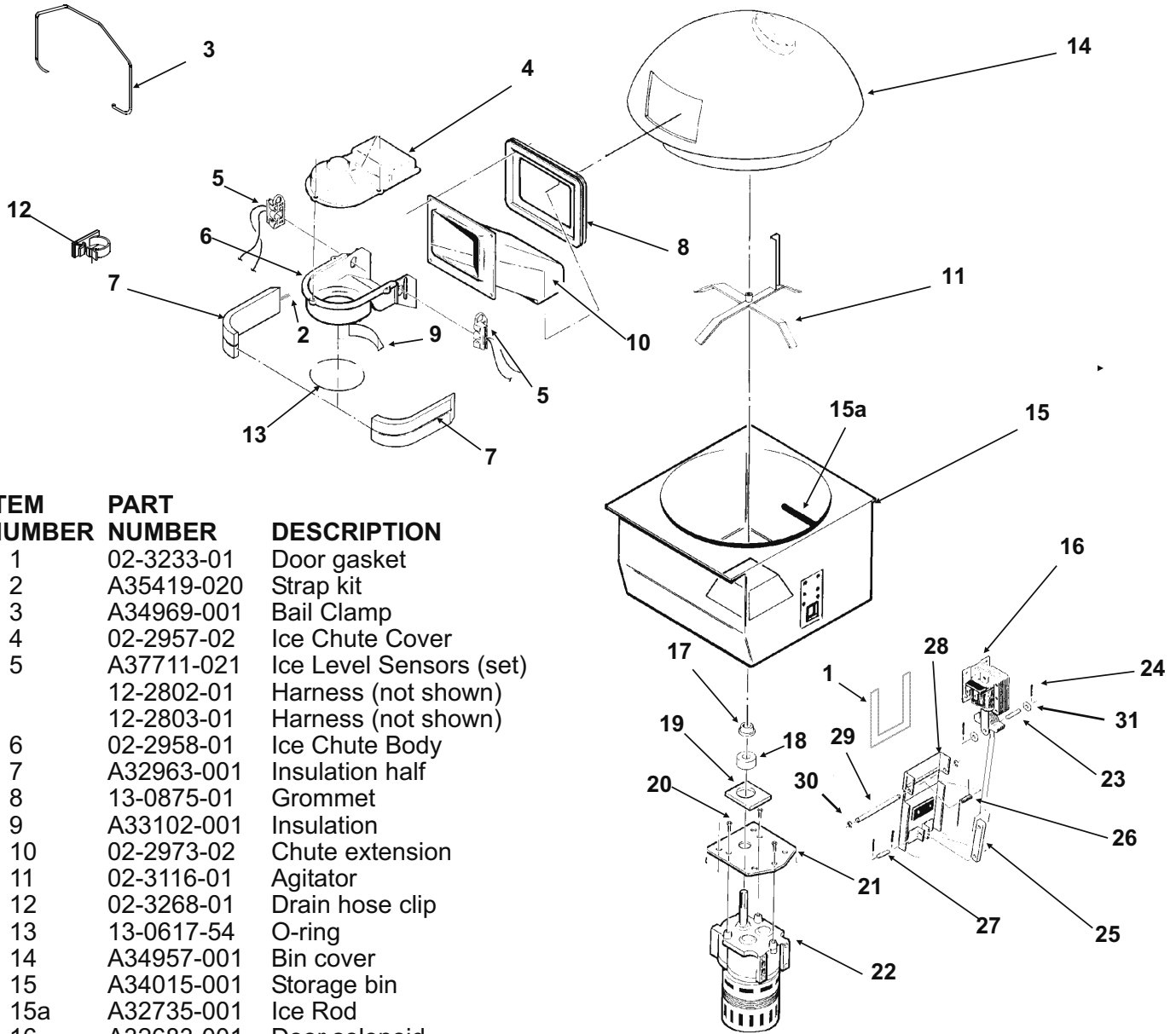

ITEM NUMBER	PART NUMBER	DESCRIPTION
1	02-3233-01	Door gasket
2	A35419-020	Strap kit
3	A34969-001	Bail Clamp
4	02-2957-02	Ice Chute Cover
5	A37711-021	Ice Level Sensors (set)
	12-2802-01	Harness (not shown)
	12-2803-01	Harness (not shown)
6	02-2958-01	Ice Chute Body
7	A32963-001	Insulation half
8	13-0875-01	Grommet
9	A33102-001	Insulation
10	02-2973-02	Chute extension
11	02-3116-01	Agitator
12	02-3268-01	Drain hose clip
13	13-0617-54	O-ring
14	A34957-001	Bin cover
15	A34015-001	Storage bin
15a	A32735-001	Ice Rod
16	A32683-001	Door solenoid
17	A32698-001	Seal
18	A32693-001	Foam seal (round)
19	A32692-001	Foam seal
20	03-1418-15	Screw
21	A34017-001	Plate
22	12-2368-01	Gearmotor Assy
	A32672-001	Heater for gearmotor
23	A32685-001	Linkage pins, med.
24	03-0396-01	Cotter pin
25	02-3206-01	Solenoid linkage
26	A32690-001	Door spring
27	A32687-001	Linkage pins, small
28	A32787-001	Door
29	A32684-001	Long Axle
30	03-1539-09	"C" Clip
31	03-1407-02	Washer

# MDT6N SERVICE PARTS

## Air Cooled Refrigeration

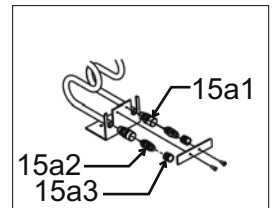
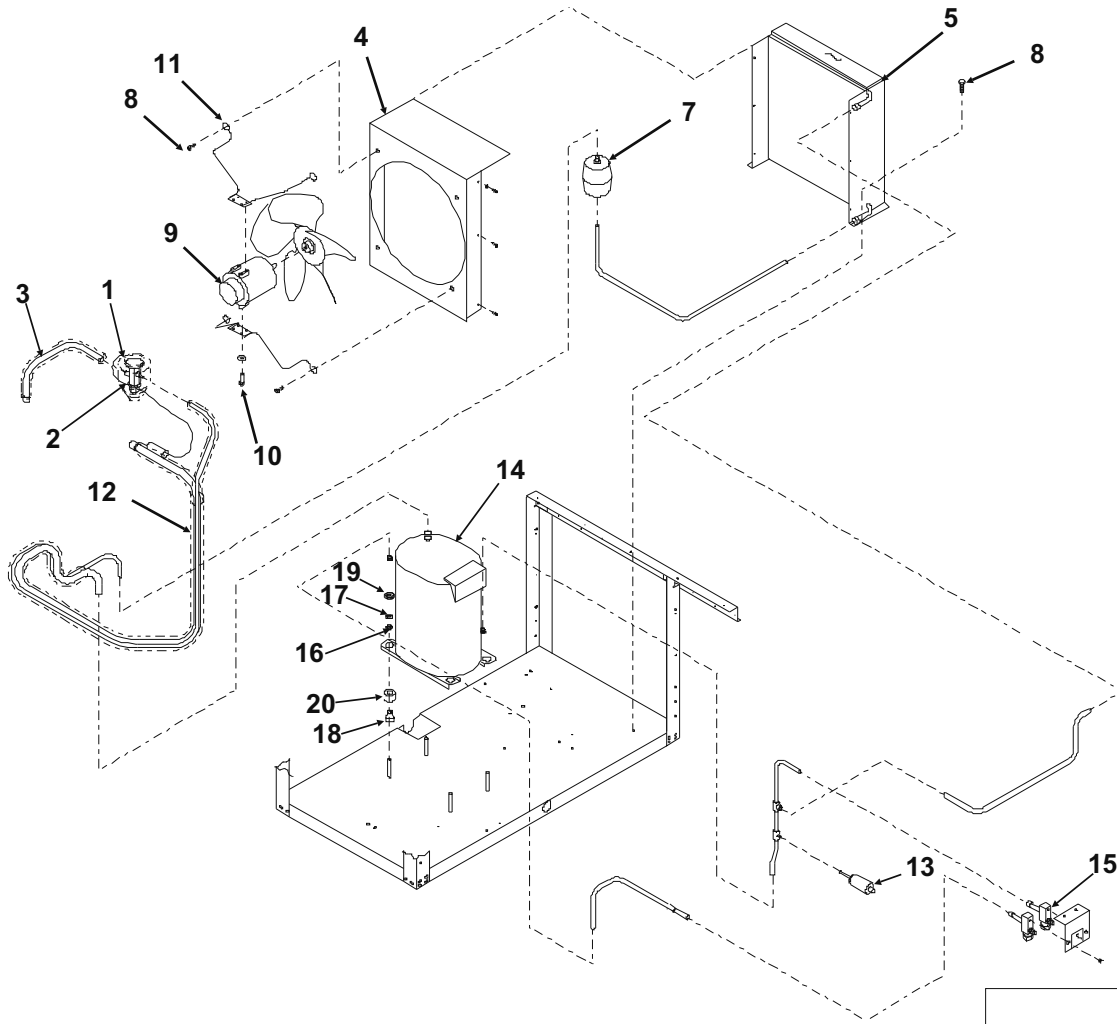

ITEM NUMBER	PART NUMBER	DESCRIPTION
1	02-4406-01	Insulation
2	11-0488-21	Thermo expansion valve
3	ref only	Evaporator inlet
4	A35911-001	Fan shroud
5	18-8732-01	Condenser
6	18-3732-01	Fan blade
7	02-3319-02	Dryer
8	03-1645-01	Screw
9	18-5505-01	Fan Motor
10	03-1531-08	Screw
11	02-3333-01	Fan motor bracket
12	A35949-001	Suction line
13	11-0501-22	Hi press. cut out
14	18-8721-21	Compressor A- H series
	18-8711-50	Overload for above
	18-8949-21	Compressor J series
	18-8949-50	Overload for above

ITEM NUMBER	PART NUMBER	DESCRIPTION
15	16-0832-20	Access Valve
	16-0832-02	Stem cap
	16-0832-03	Core cap
16	03-1407-07	Washer
17	03-1410-04	Lockwasher
18	18-2200-28	Grommet
19	03-1406-10	Hex nut
20	18-2200-27	Metal sleeve

Access valve change, November 2007

15a1	16-1137-01	Access valve seat
15a2	16-1139-01	Access valve core
15a3	16-1140-01	Cap

# MDT6N SERVICE PARTS

## Water Cooled Refrigeration

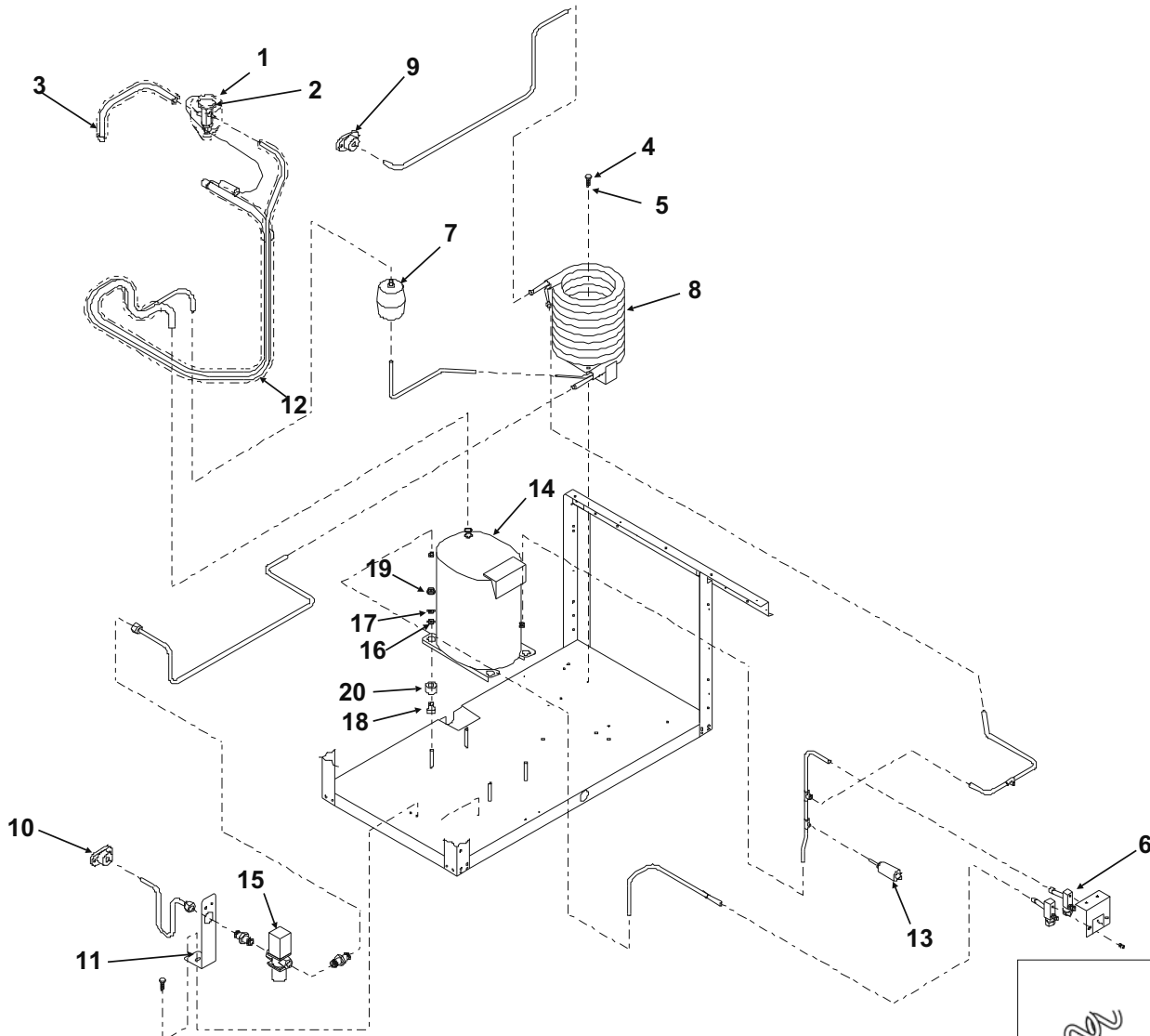

ITEM NUMBER	PART NUMBER	DESCRIPTION
1	02-4406-01	Insulation
2	11-0488-21	Thermo expansion valve
3	no number	Evap inlet tube
4	03-1645-01	Screw
5	03-1407-05	Washer
6	16-0832-20	Access Valve
	16-0832-02	Stem cap
	16-0832-03	Core cap
7	02-3319-02	Dryer
8	18-3306-25	A series WC condenser
	18-8871-21	B-J series WC condenser
9	16-1154-22	Adaptor flange
10	16-1154-23	Adaptor flange
11	A33990-015	Bracket
12	A35949-001	Suction line
13	11-0501-22	Hi press. cut out
14	18-8721-21	Compressor A- H series
	18-8711-50	Overload for above
	18-8949-21	Compressor J series
	18-8949-50	Overload for above

ITEM NUMBER	PART NUMBER	DESCRIPTION
15	11-0478-01	Water reg. valve
16	03-1407-07	Washer
17	03-1410-04	Lockwasher
18	18-2200-28	Grommet
19	03-1406-10	Hex nut
20	18-2200-27	Metal sleeve

Access valve change, November 2007		
6a1	16-1137-01	Access valve seat
6a2	16-1139-01	Access valve core
6a3	16-1140-01	Cap

# MDT6N SERVICE PARTS

## Water System

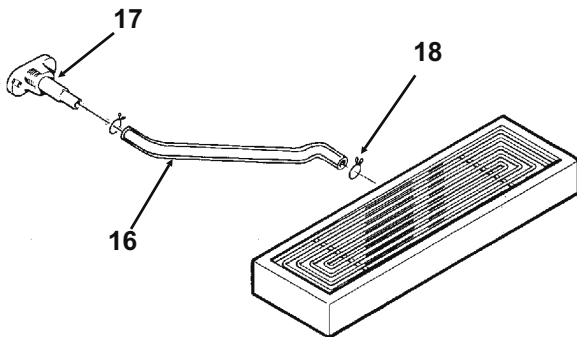
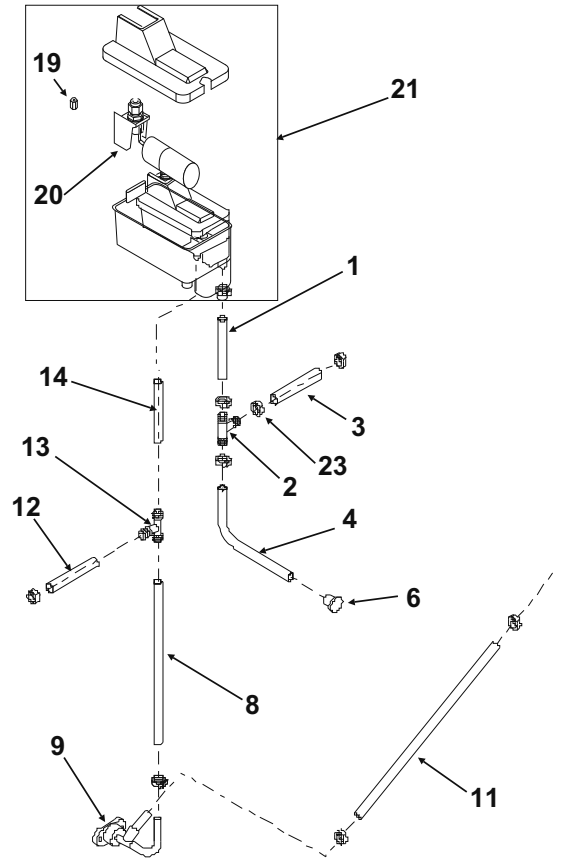
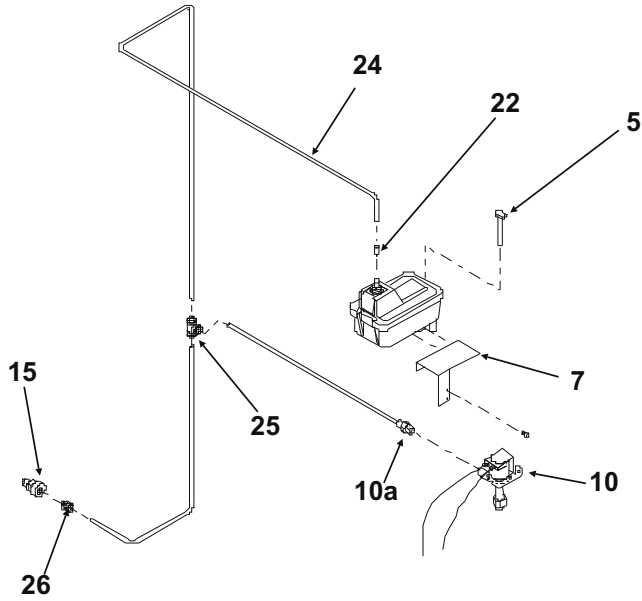

ITEM NUMBER	PART NUMBER	DESCRIPTION
1	13-0674-06	Tubing, 11" req.
2	16-0670-01	Tee
3	05-0501-01	Evap. inlet tubing (preformed)
4	13-0674-06	Tubing, 11" req.
5	A33101-022	Water sensor
6	13-0840-01	Rubber plug
7	A35952-001	Reservoir bracket
8	13-0079-03	Drain tubing, 25" req.
9	A32294-001	Drain assy
10	12-1646-05	Inlet water valve
10a	16-1046-01	Connector
11	13-0674-06	Drain tubing 24" req.
12	13-0079-03	Drain tubing 4" req.
13	16-0670-02	Tee
14	13-0079-03	Drain tubing 24" req.
15	16-0835-01	Water inlet fitting
16	13-0674-07	Sink drain tube 33" req.
17	02-3692-23	Drain casting for sink drain
18	02-2814-10	Hose clamp
19	02-3266-03	Plunger/seat
20	02-3266-02	Float valve
21	02-3266-01	Reservoir, A-H series incl 19, 20
	02-3371-01	Reservoir, J series incl 19, 20
22	16-0871-01	Insert
23	02-2814-09	Hose clamp
24	13-0895-01	Hose, need 38"
25	16-1040-01	Tee
26	16-1039-01	Connector



# MDT6N SERVICE PARTS

## Evaporator

ITEM NUMBER	PART NUMBER	DESCRIPTION
1	03-1420-03	Cap Screw
	03-1417-13	Lockwasher
2	A33194-020	Evaporator
3	02-4358-01	Insulation wrap
4	same as item 3, use 1 per unit	
5	02-0929-23	Water seal
6	A32777-001	Retaining ring for seal
7	02-3837-01	Drip pan

ITEM NUMBER	PART NUMBER	DESCRIPTION
8	13-0704-00	Gasket
9	02-4663-01	Water shed
10	02-2977-01	Lip Seal
11	13-0617-54	O-Ring
12	A32900-020	Breaker (incl. 10,14,22)
13	03-1544-08	Soc. head screw
14	13-0617-45	O-ring
15	03-1405-52	Hex cap screw
16	02-3001-01	Ice sweep
17	13-0871-01	Water shed
18	02-2978-01	Lip seal
19	02-3128-20	Breaker cover
20	13-0617-52	O-ring
21	08-0660-01	Auger stud
22	A34559-020	Bearing
23	A38071-021	Auger

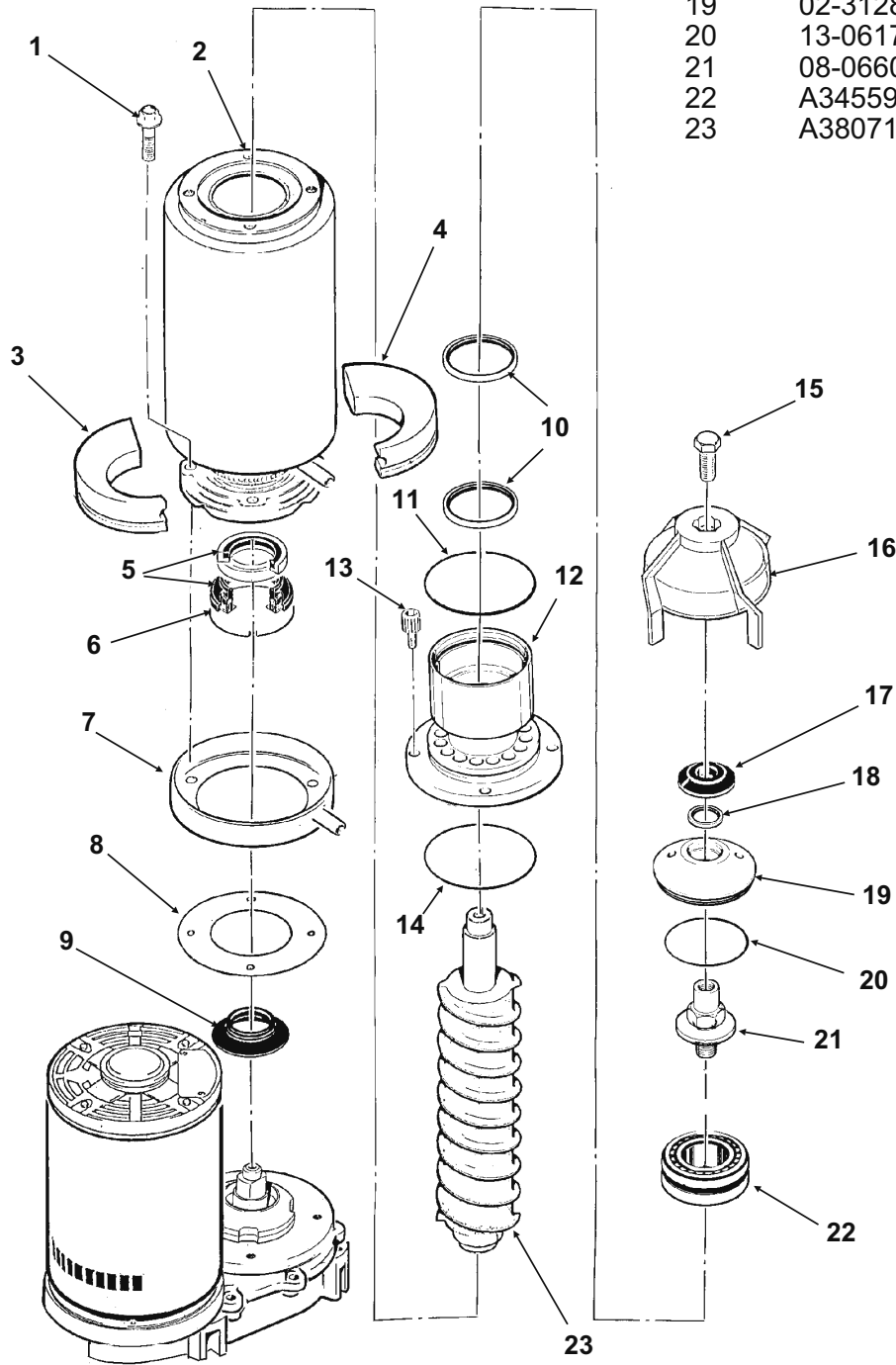

# MDT6N SERVICE PARTS

## Gearmotor

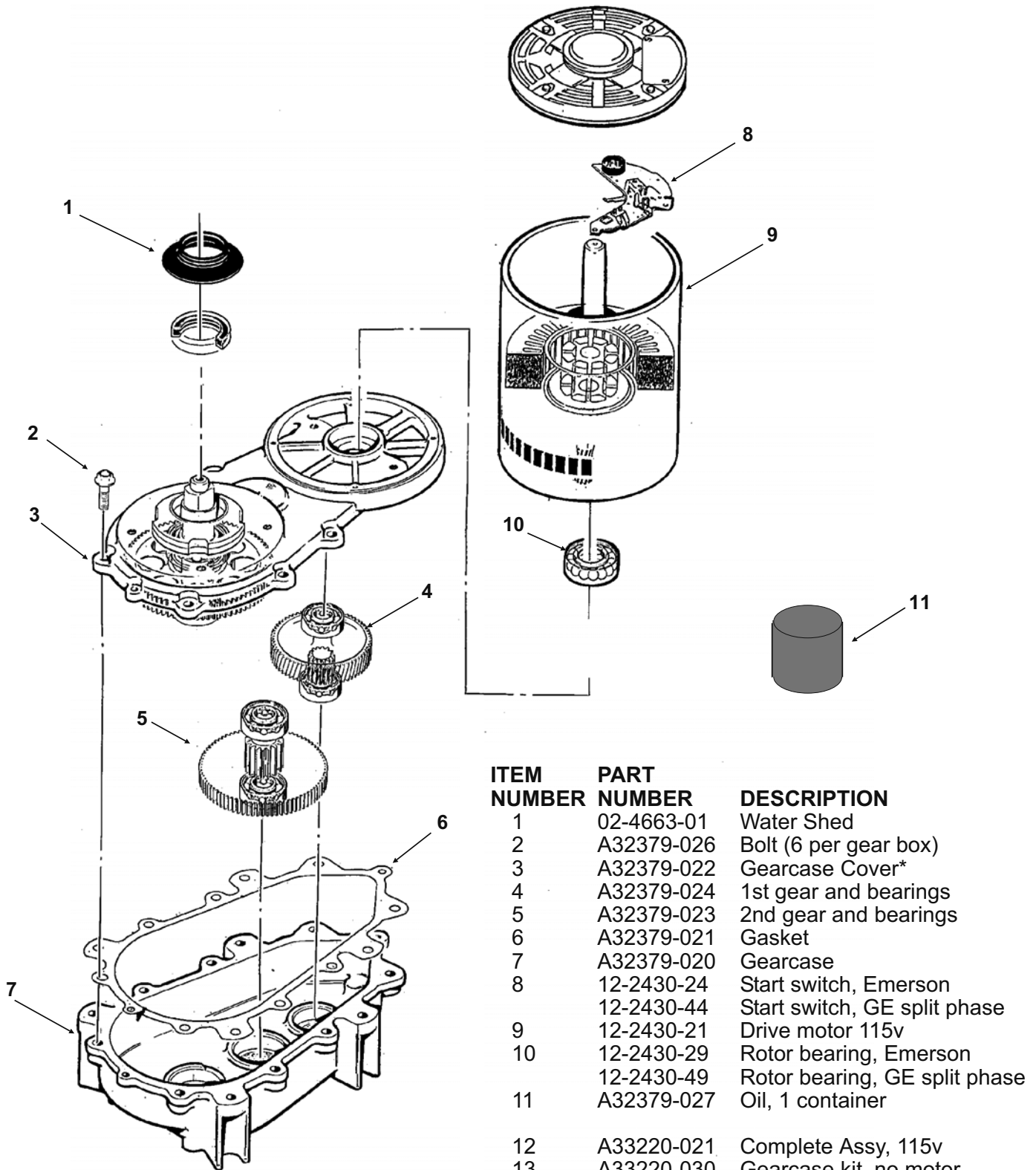

ITEM NUMBER	PART NUMBER	DESCRIPTION
1	02-4663-01	Water Shed
2	A32379-026	Bolt (6 per gear box)
3	A32379-022	Gearcase Cover*
4	A32379-024	1st gear and bearings
5	A32379-023	2nd gear and bearings
6	A32379-021	Gasket
7	A32379-020	Gearcase
8	12-2430-24	Start switch, Emerson
	12-2430-44	Start switch, GE split phase
9	12-2430-21	Drive motor 115v
10	12-2430-29	Rotor bearing, Emerson
	12-2430-49	Rotor bearing, GE split phase
11	A32379-027	Oil, 1 container
12	A33220-021	Complete Assy, 115v
13	A33220-030	Gearcase kit, no motor

\* Note: Gearcase cover includes cover, output shaft, key, output gear, bearings and seal.

# MDT6N SERVICE PARTS

## Control Box

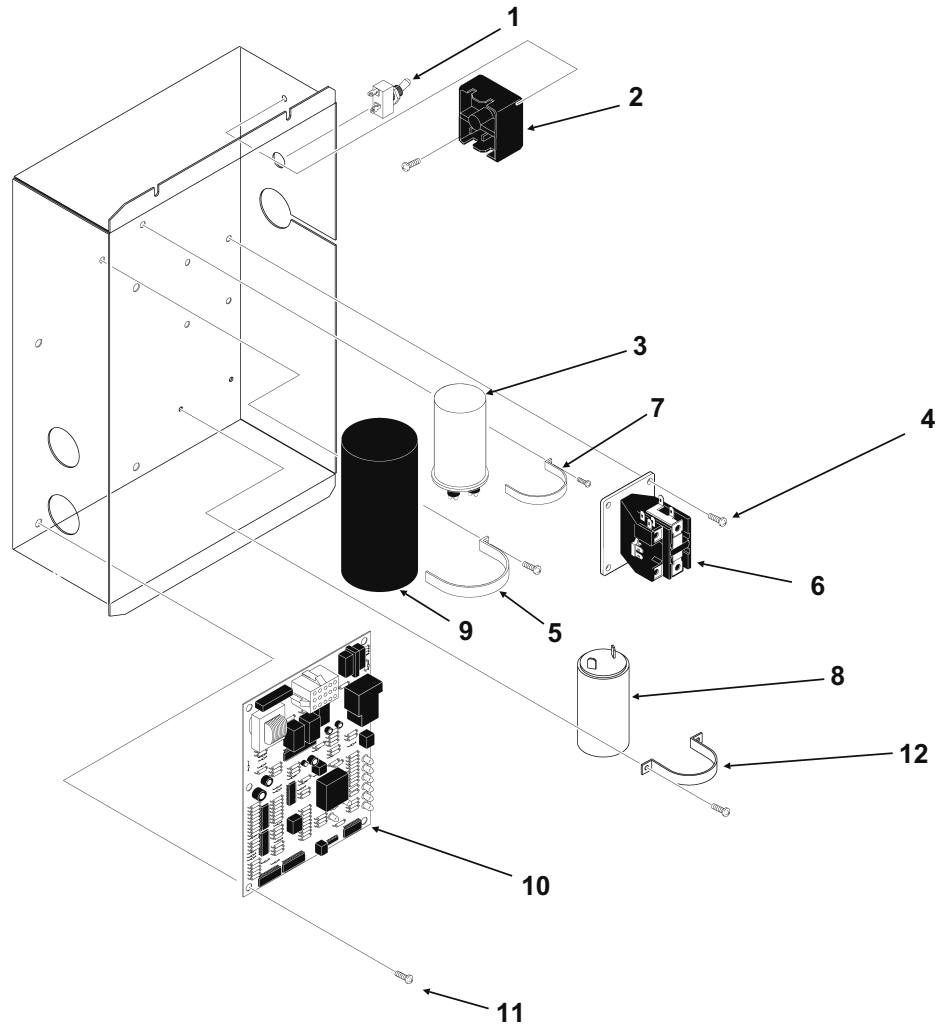

ITEM NUMBER	PART NUMBER	DESCRIPTION
1	12-0426-01	Toggle switch
2	18-1903-50	Potential Relay, A- H series
	18-1903-44	Start relay, J series
3	18-1902-45	Run capacitor for compressor, A- H series
	18-1902-64	Run capacitor for compressor, J series
4	03-1531-01	Screw
5	A35971-001	Capacitor bracket
6	12-2469-03	Contactor 115v
7	A35971-002	Capacitor bracket
8	18-3701-01	Run capacitor-bin drive motor
9	18-1901-03	Start capacitor, A-H series
	18-1901-65	Start capacitor, J series
10	12-2843-21	Circuit board
11	A33219-001	Standoff

NOT ILLUSTRATED		
12	A34528-015	Control box cover

# MDT6N SERVICE PARTS

## Wiring Diagram

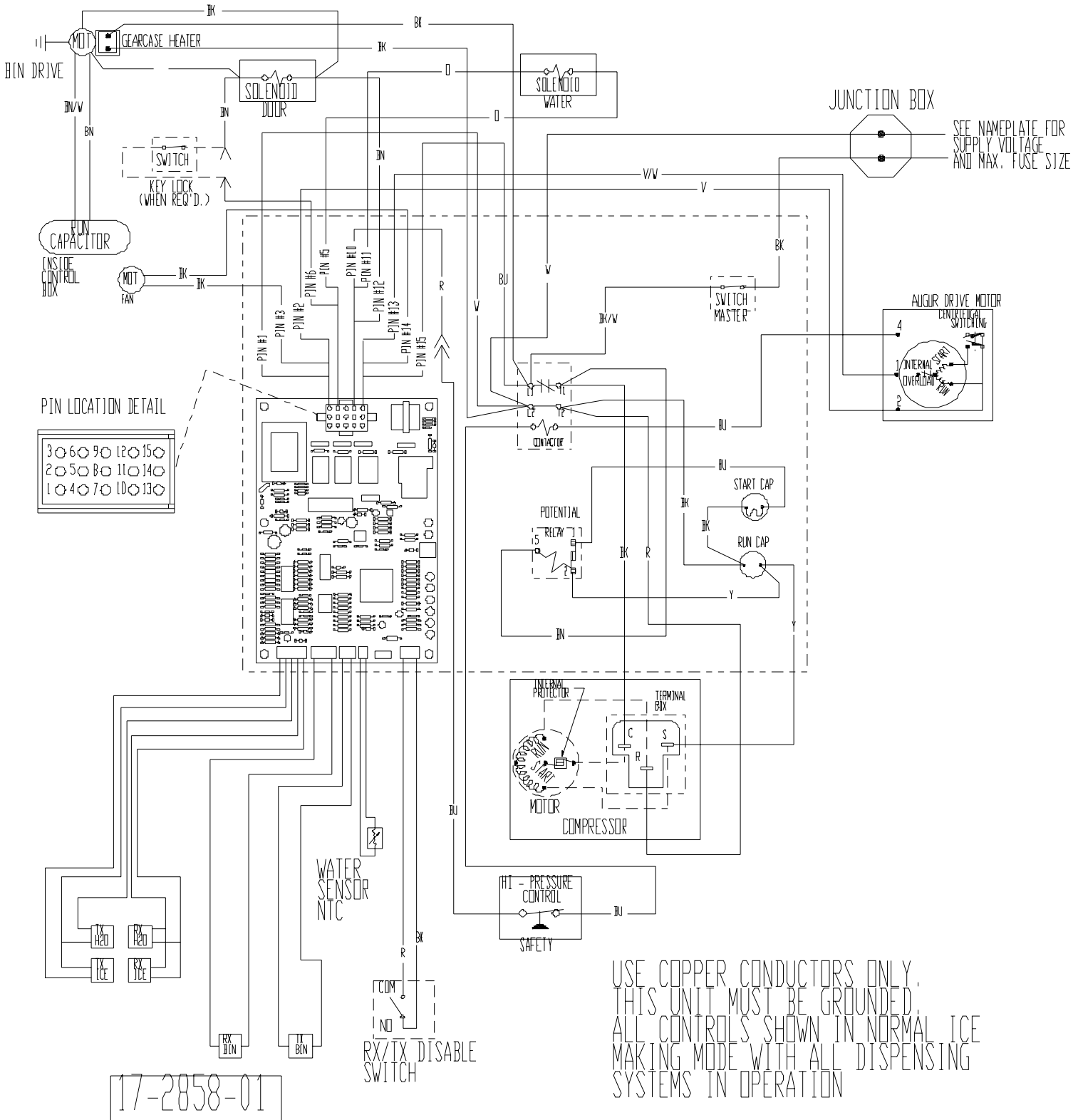

# MDT6N SERVICE PARTS

## Schematic Diagram

