

# INTRODUCTION

---

To the owner or user: The service manual you are reading is intended to provide you, and the maintenance or service technician with the information needed to install, start up, clean, maintain, and service this ice system.

## TABLE OF CONTENTS

For the Installer	
Specifications . . . . .	Page 2
Location/Assembly . . . . .	Page 4
For the Plumber . . . . .	Page 5
For the Electrician . . . . .	Page 6
Final Check List . . . . .	Page 7
Start Up . . . . .	Page 8
Component Description . . . . .	Page 9
Electrical Sequence . . . . .	Page 10
Operation . . . . .	Page 11
Maintenance & Cleaning . . . . .	Page 13
Service Diagnosis . . . . .	Page 15
Removal and Replacement	
Ice Breaker and Auger . . . . .	Page 17
Water Seal . . . . .	Page 17
Gearmotor Assembly . . . . .	Page 18

***Parts lists and wiring diagrams are located in the center of this manual, printed on yellow paper.***

# MF400

## FOR THE INSTALLER

The MF400 is designed to fit the following Scotsman storage bins.

- BH550 with bin top KBT20
- HTB500 with bin top KBT20

The normal finish for the machine is enamel sandalwood. An optional stainless steel panel kit (SPKMF400A) may be ordered and field installed to convert the unit to a stainless steel finish.

When installing the new system, check that everything needed is on site:

- Correct Ice Machine (voltage and type)
- Correct Bin
- Correct Bin Top
- Legs for the bin

### SPECIFICATIONS :

#### ICEMAKER

Note: This service manual is for the current MF400 "B" model, but applies in general to the prior "A" model. The primary differences are in the evaporator, spout and the ice chute.

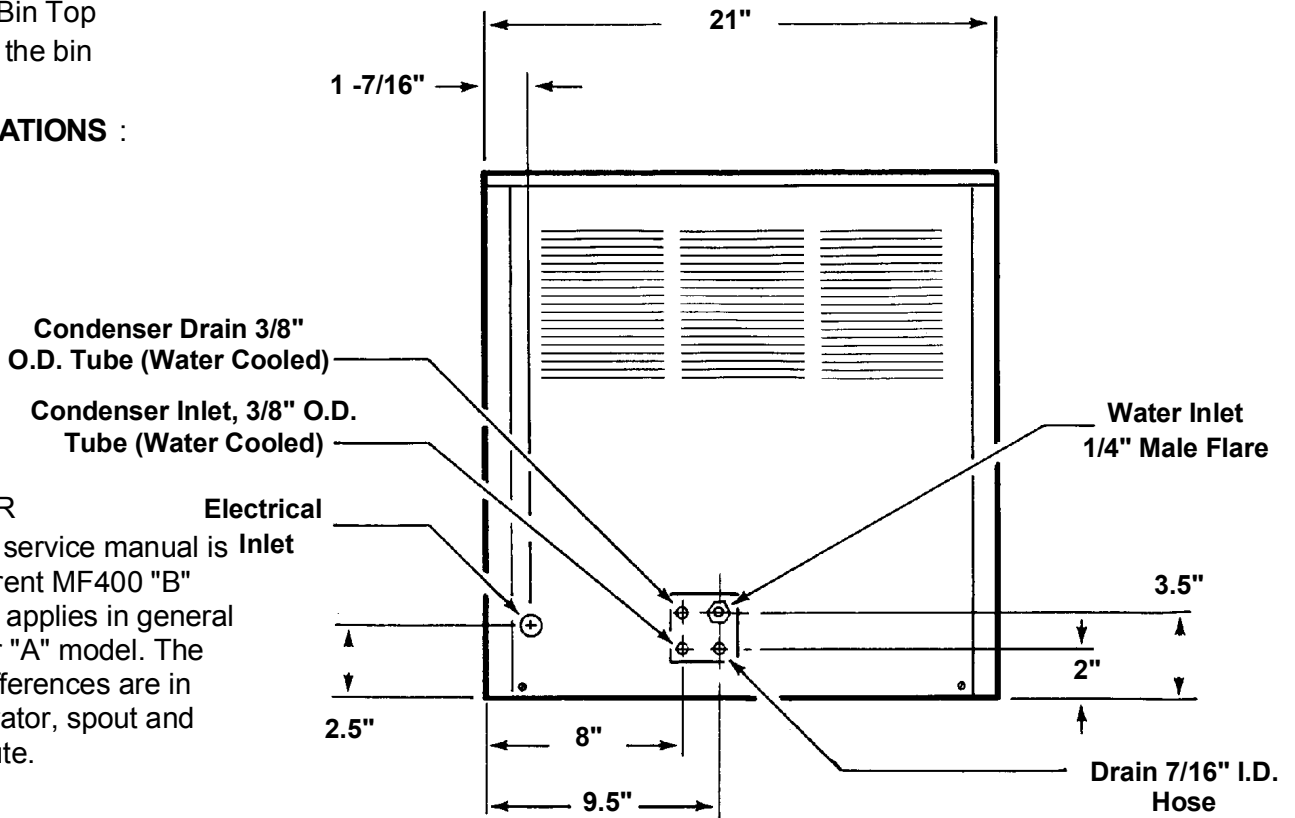

Model Number	Dimensions (w/o Bin) H" x W" x D"	Basic Electrical	Condenser Type	Minimum Circuit Ampacity+	Maximum Fuse Size
MF400AE-1B	21.5 x 21 x 22	115/60/1	Air	12.7	15
MF400WE-1B	same	same	Water	11.4	15

\*Minimum Circuit Ampacity is used to determine wire size and type per National Electric Code.

## FOR THE INSTALLER

### Installation Limitations:

This ice system is designed to be installed indoors, in a controlled environment:

	Min	Max
Air Temperature	50 <sup>0</sup> F.	100 <sup>0</sup> F.
Water Temperature	40 <sup>0</sup> F.	100 <sup>0</sup> F.
Water Pressure	20 psi	80 psi
Voltage	-10%	+10%

(Compared to the Nameplate)

Operating the machine outside of the limitations is misuse and can void the warranty.

Scotsman Ice Systems are designed and manufactured with the highest regard for safety and performance. They meet or exceed the standards of UL, NSF, and CSA.

Scotsman assumes no liability or responsibility of any kind for products manufactured by Scotsman that have been altered in any way, including the use of any part and/or other components not specifically approved by Scotsman.

Scotsman reserves the right to make design changes and/or improvements at any time. Specifications and design changes are subject to change without notice.

### Water Limitations:

An ice machine is a food manufacturing plant; it takes in a raw material, water, and turns it into a food product, ice. The purity of the water is very important in obtaining pure ice and in maximizing product life. This section is not intended as a complete resource for water questions, but it does offer these general recommendations:

1. Filter the water used to make ice. That is the water going to the "potable" water connection. Water filters vary greatly in ability and function. Install one that filters out suspended solids to a dimension of 5 microns or smaller. The finer the filter the better, but finer filters will clog sooner than course ones. It may be necessary to add a course filter ahead of the fine filter to prolong filter life.
2. Check with a water treatment specialist for a water test, and recommendations regarding filters and treatment.

### Service Limitations:

There must be space above, at least one side, to the back, and of course the front for service access.

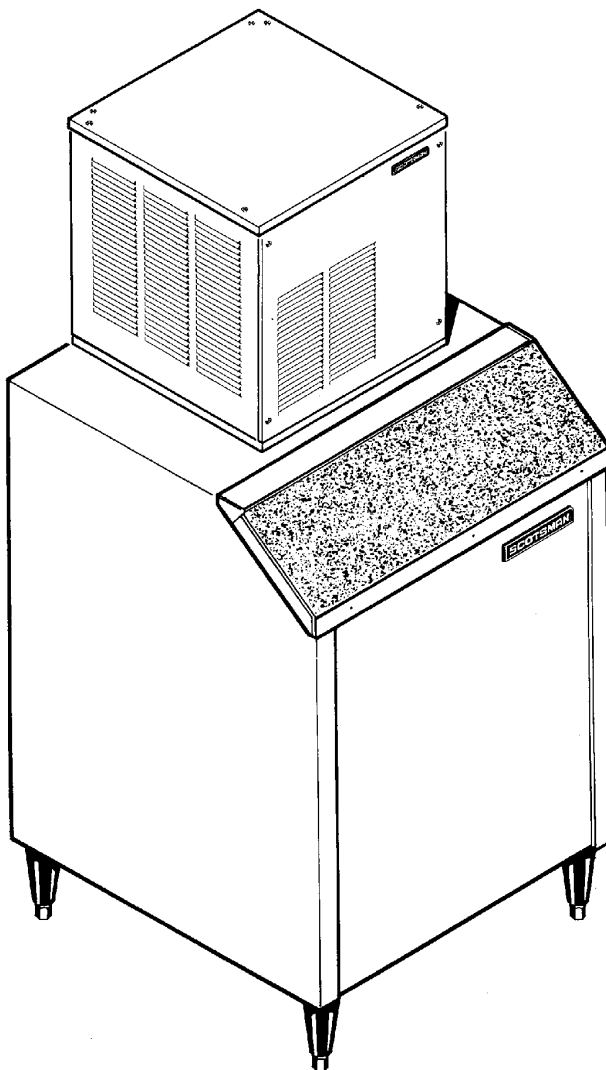

# MF400

## FOR THE INSTALLER

### Location

After uncrating and inspection, the unit is ready to be installed.

It is important that the machine be installed in a location where it has enough space around it for service, and a minimum of 6" be allowed all sides for air circulation. The machine, when air cooled, draws air in the front, and exhausts it out the sides and back.

Try to avoid hot, dirty and crowded locations. Be sure that the location for the machine is within the limitations described on page 3.

### Storage Bin

Tip the uncrated storage bin on its back, using parts of the carton to protect the exterior finish. Install the legs into the threaded holes in the bottom of the bin. Turn the leg levelers all the way in preparation for leveling later.

Return the bin to the upright position, remove paper covering the bin gasket.

Install bin top if required.

Note: Do not push bin into position: but lift it there. Pushing a bin, especially one with ice in it, can cause damage to the legs and the leg mounts.

### Ice Maker

The machine is heavy, so the use of a mechanical lift is recommended for lifting the machine high enough to install on top of the bin. After the machine is placed on the bin, line it up so that the ice discharge opening in the base of the machine is over the open hole in the bin top.

### Ice Chute Installation

After the MF400B has been installed on the ice storage bin, the ice chute needs to be installed:

1. With the top panel off, remove all packing material (bubble pack) from above the ice chute and chute cap. Cut the ty-wrap holding the chute assembly in place.
2. Remove the insulation halves and ty-wrap packed inside the cabinet, retain for later use.
3. Remove the cardboard support from under the ice chute.
4. Insert the ice chute/bin thermostat assembly into the large hole in the bottom of the ice machine. Check that bin thermostat cap tube is free from contact with most components.
5. Remove the rubber cap from the top of the ice chute. Leave one hose clamp on the chute.

6. Push the ice chute against the stainless spout (the end of the spout will go into the chute).
7. Slide the rubber cap over the top of the stainless spout. Push down until it fits tightly around the spout.
8. Secure the rubber cap to the spout with the two hose clamps, in the molded grooves; one above and one below. Keep hose clamp screws away from evaporator.
9. Attach the insulation halves around the top of the evaporator. Secure with the ty-wrap provided. Finish installation per service manual.

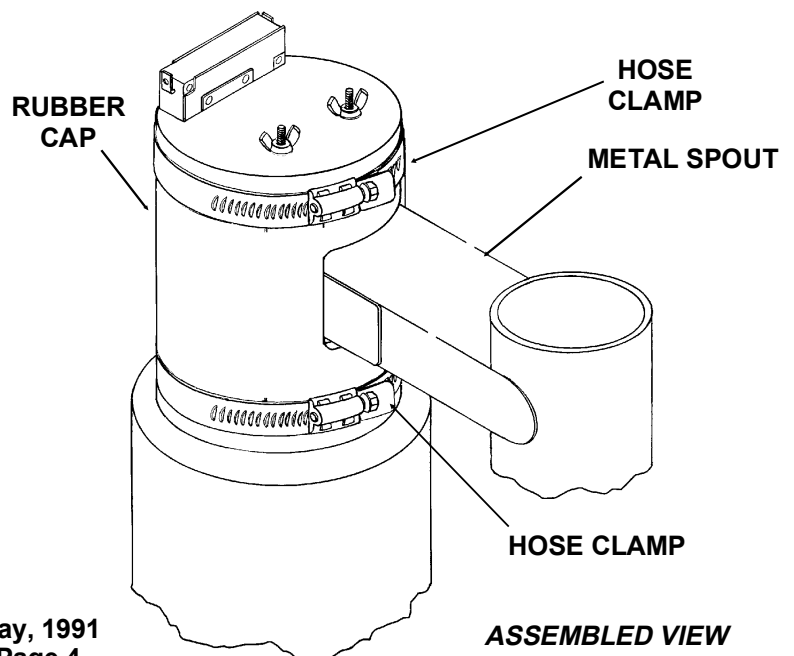
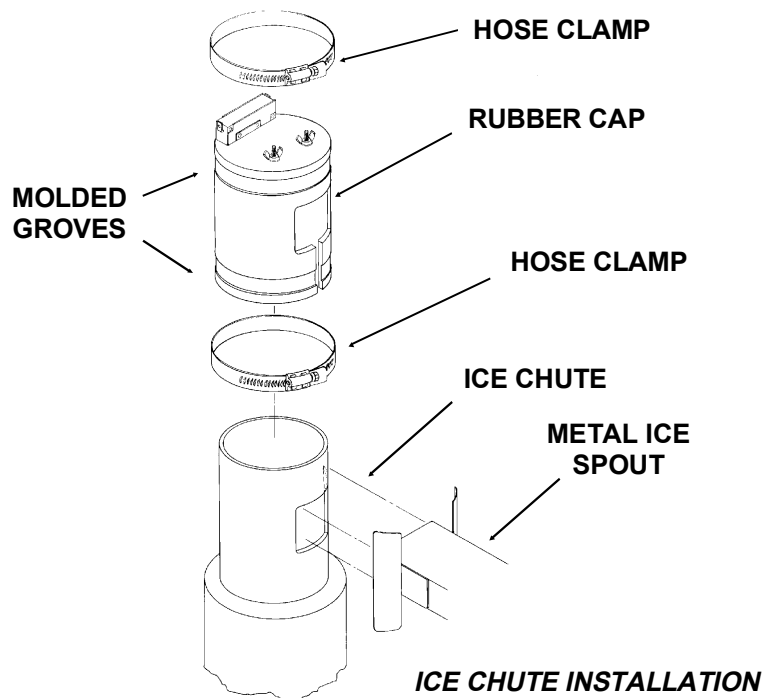

FOR THE PLUMBER

CONFORM TO ALL APPLICABLE CODES

**Water Inlet**

**Air Cooled:** The recommended water supply is cold water. Use 1/4" O.D. copper tubing, connect to the 1/4" male flare at the back of the cabinet. Install a hand valve near the machine to control the water supply.

**Water Cooled:** A separate 3/8" O.D. copper tube should be connected to the condenser inlet, with a separate hand valve to control it.

**Drains**

**Air cooled:** There is one 7/16" I.D. hose to connect to for a drain. This drain is a gravity drain, and a minimum of 1/4" per foot fall is needed for horizontal portions of the drain line.

The ideal drain receptacle is a trapped and vented floor drain.

Use only rigid tubing.

**Water Cooled Models:** In addition to the above mentioned drain, separate condenser drain must be installed. Connect to the 3/8" condenser drain tube.

**Storage Bin:** A separate gravity type drain needs to be run. This drain line should be insulated.

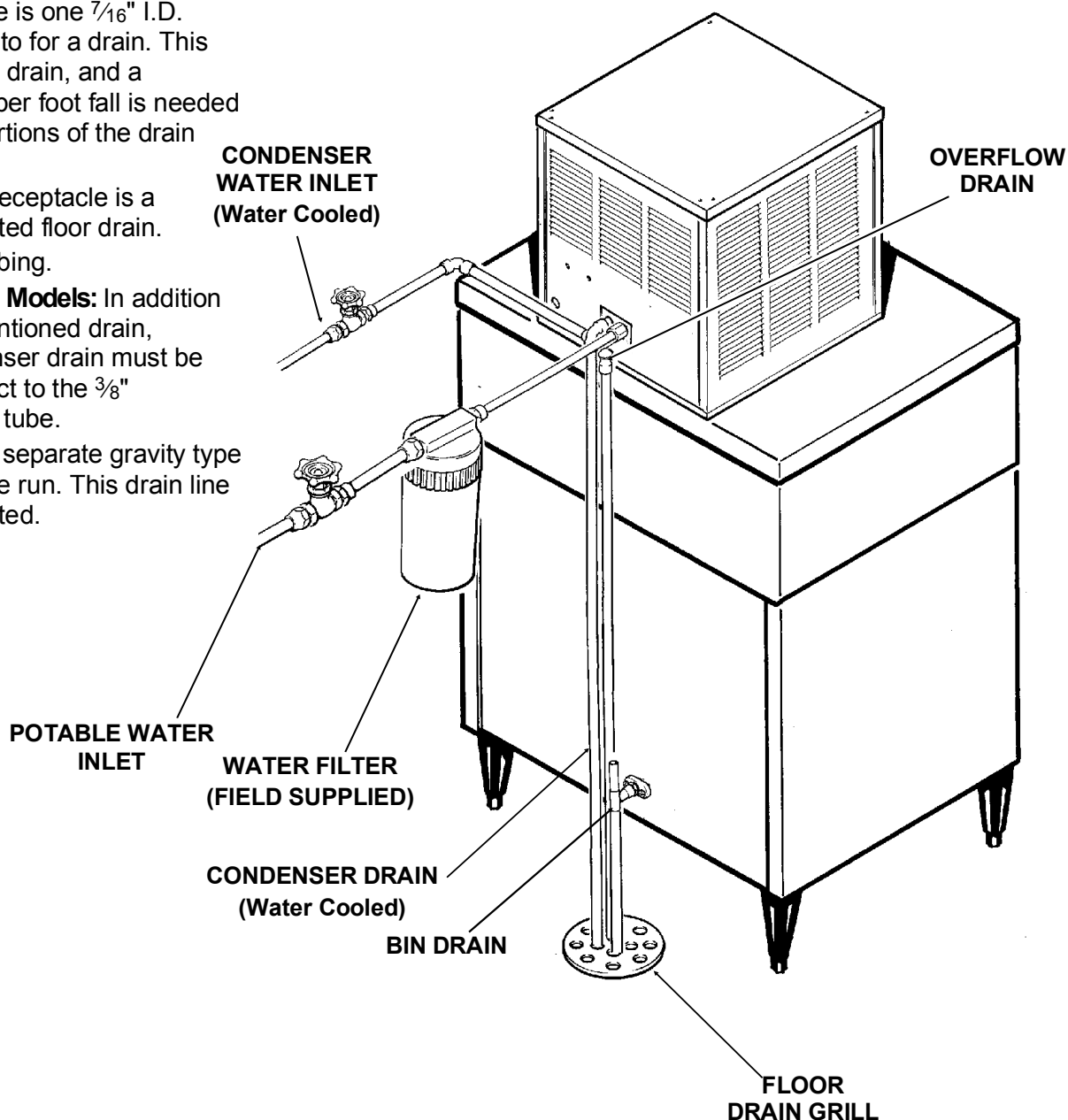

# MF400

## FOR THE ELECTRICIAN

---

### CONFORM TO ALL APPLICABLE CODES

The electrical power to the unit is to be wired through the cabinet to the control box. In the control box, connect to the terminal strip provided. Check the nameplate (located on the back of the cabinet) for the voltage requirements, and for the minimum circuit ampacity. The machine requires a solid chassis to earth ground wire.

The icemaker should be connected to it's own electrical circuit so that it is individually fused. Voltage variation must remain within design limitations, even under starting conditions.

All external wiring must conform to national, state, and local electrical codes. The use of a licensed electrician is required to perform the electrical installation.

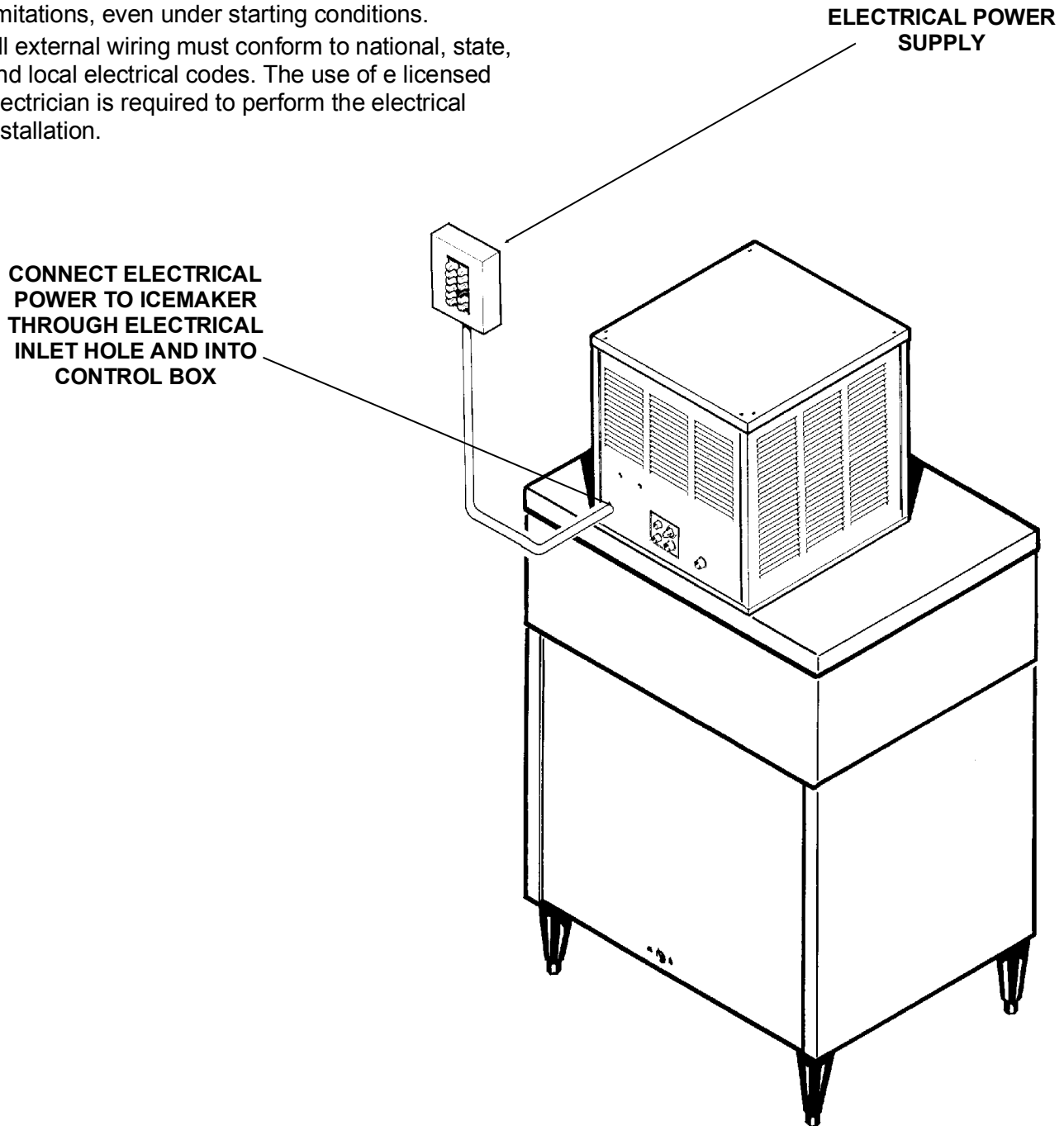

**FOR THE INSTALLER: Final Check List**

---

1. Is the ice system installed indoors in a location where the air and water temperatures are controlled, and where they do not exceed the design limitations?
2. Is there an electrical service disconnect within sight of the installed machine?
3. Have all the plumbing connections been made and checked for leaks?
4. Has the machine and bin been leveled?
5. Is there a minimum of 6" clearance around the machine for proper service and air circulation?
6. Is the water pressure a minimum of 20 psig?
7. Has the ice discharge tube been installed?
8. Is there a water shut off installed near the machine?
9. Have all shipping materials been removed?

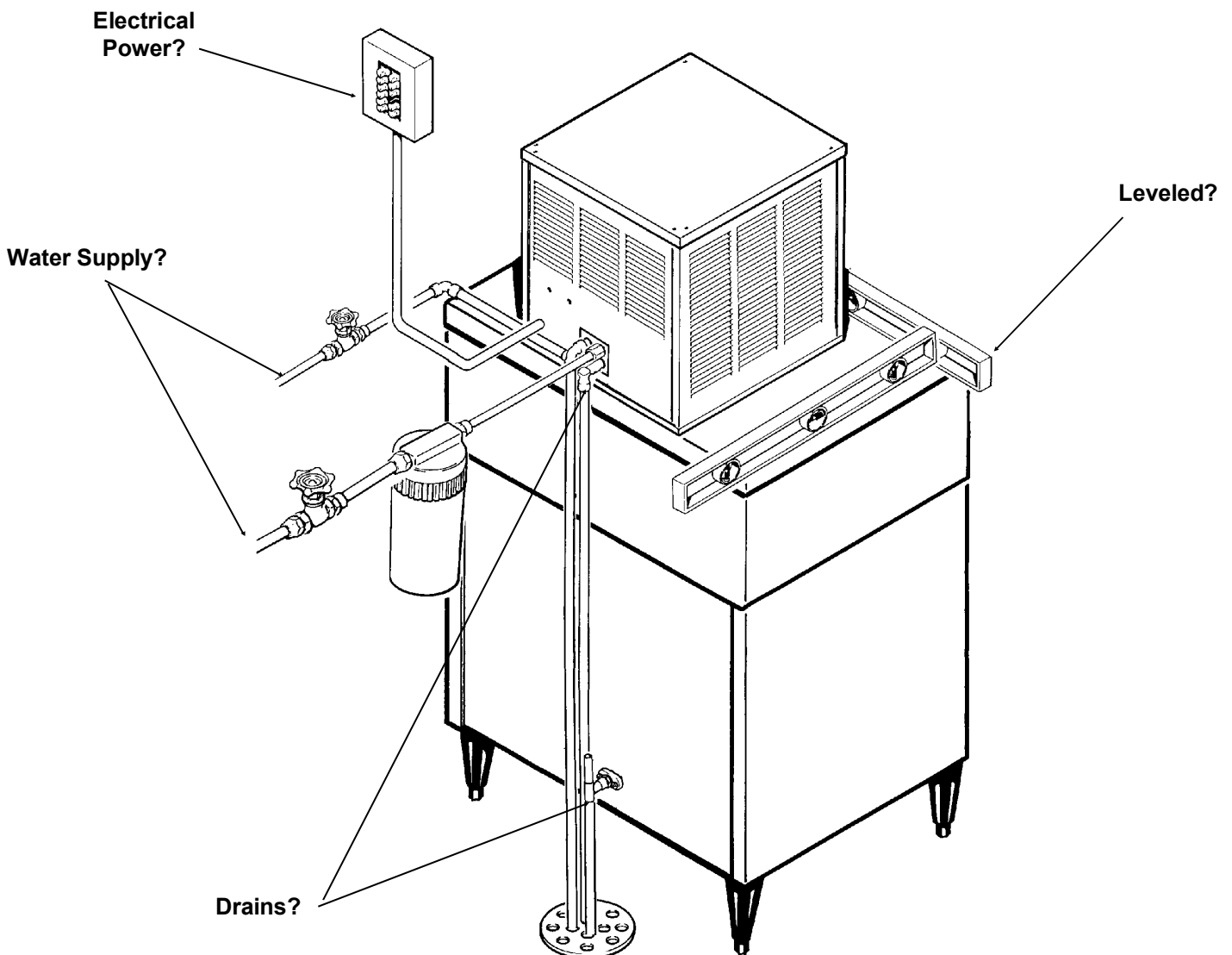

# MF400

## START UP

---

1. Remove screws and the front panel.
2. Open the water shut off valve.
3. Observe that the water flows into the water reservoir, fills up the water inlet tube to the evaporator, the float moves up with the water level, and the float shuts off the water flow, about  $\frac{3}{8}$ " below the molded horizontal line on the water reservoir.
4. Switch on the electrical power to the unit.
5. Switch the master switch to ON.
6. After a few minutes of operation: water should begin to flow from the reservoir to the evaporator; the air cooled condenser should begin to discharge warm air, or the water cooled condenser should beginning to discharge warm water; and the unit should begin to drop ice into the storage bin.  
If desired, the refrigeration pressures can be checked:
  - The air cooled discharge pressure should be about 125-135 PSIG and the suction pressure should be about 12-15 PSIG.
  - The water cooled discharge pressure should be set at 135 PSIG.
  - Gearmotor amps should be about 2.8 - 3.2.
  - Compressor amps should be about 8.5 - 9.
7. Let the unit operate for 15-30 minutes, checking for water leaks, or excessive noise from vibrating components.
8. Block off the ice discharge tube, and check if the bin thermostat shuts off the machine. After it shuts off the compressor, the auger motor should run for a few minutes more. Allow the ice in the tube to fall away, and check that the compressor restarts.
9. Explain the operation and maintenance requirements to the user, inform the user of the telephone number of the service agency servicing the machine, and give the user the service manual.



## COMPONENT LOCATION: Control Box

**Auger Delay Pressure Control:** This pressure switch, connected to the low side of the refrigeration system, controls the auger drive motor.

**Low Pressure Control:** This pressure switch, connected to the low side of the refrigeration system, is normally closed when the machine is operating. If the low side pressure should drop too low, the control will open (at 0-4 PSIG), stopping the ice maker. It is an automatic reset.

**High Pressure Control:** The pressure switch, used on water cooled models only, is designed to open and shut off the machine should the high side refrigeration pressure become too high, usually as a result of not enough water through the water cooled condenser.

It is a manual reset.

**On-Off switch:** This toggle switch shuts off the machine. It is not a complete disconnect.

**Bin Thermostat:** This thermostat turns the machine on and off in response to changes in temperature of the capillary tube. It opens at 35° F. and closes at 45° F. The capillary tube is mounted on the inside of the ice chute.

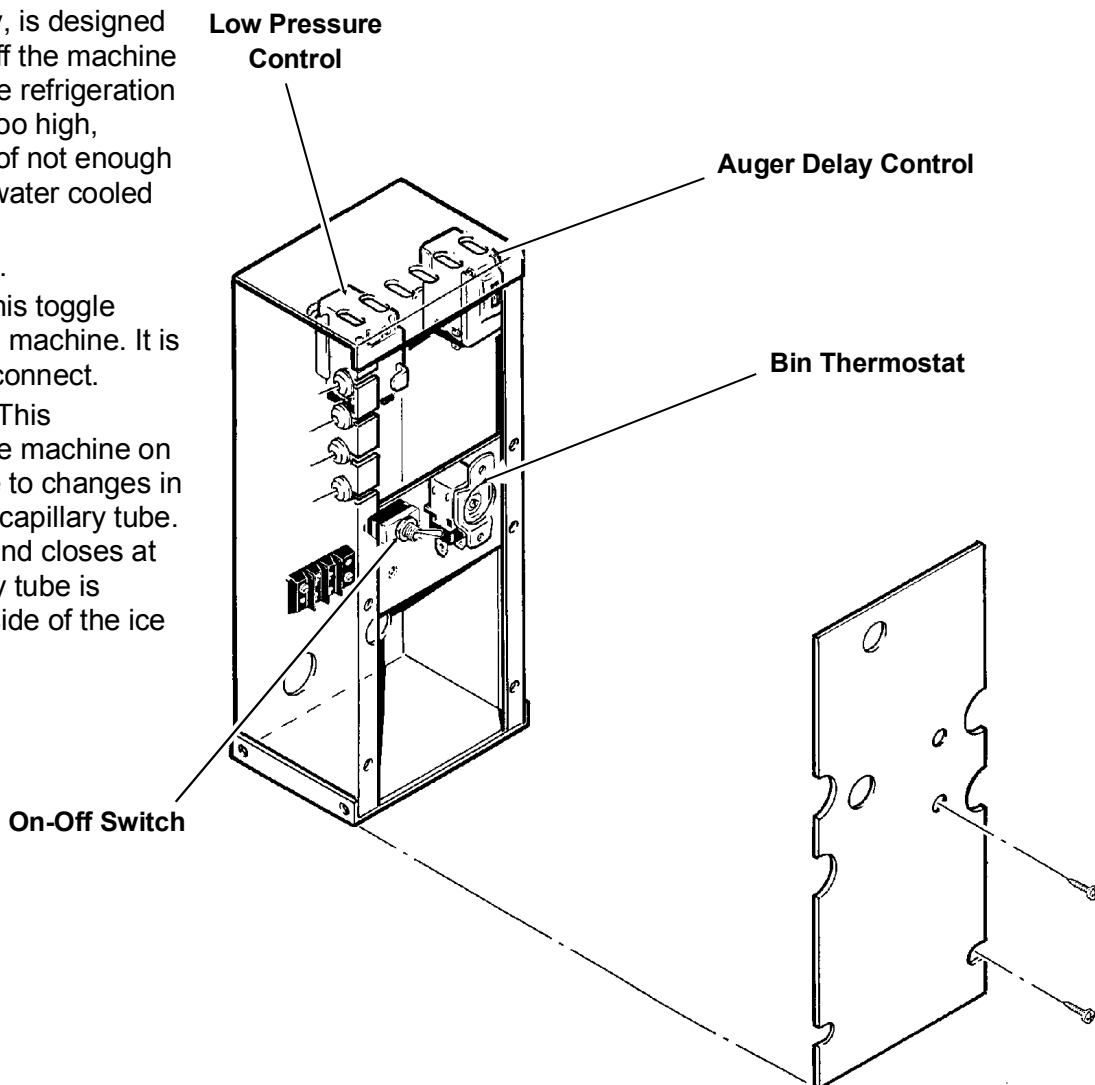

# MF400

## ELECTRICAL SEQUENCE

---

There are two circuits in the MF400: one is a series circuit with several switches connected in series to the compressor. The other is a parallel branch of the series circuit, controlling the gear drive motor.

- The series circuit begins at the terminal strip in the control box. From there, the line side power is connected to the Master Switch.
- When the master switch is closed, the power is then connected to the Spout Switch. This switch, located on the top of the ice chute, is closed unless the ice chute has overflowed with ice, it is an automatic reset.
- From the spout switch the line side power now is connected to the Low Pressure Control (air cooled) or the High Pressure Control and then the Low Pressure Control (water cooled). These controls, connected to the refrigeration system, are designed to open whenever higher (high pressure control) pressures or lower (low pressure control) pressures are sensed. The high pressure control is a manual reset, the low pressure control is an automatic reset.
- The line side power is also connected, in a parallel circuit, to terminal 1 of the Auger Delay pressure control. This pressure control, connected to the low side of the refrigeration system, is designed as a by-pass circuit to the auger drive motor whenever the low side refrigerant pressure is at its normal ice making range. At start up, the contacts between terminals 1 and 2 are open. The line side power does not pass any further through the auger delay pressure control, until the compressor starts, and the low side pressure drops.
- The next control the power is connected to is the Low Water Pressure Control. This switch is designed to open should the water pressure to the machine drop too low.
- The next control is the Bin Thermostat. It is closed when there is no ice on the portion of the control inside the ice chute. It is open when there is ice on the portion of the control inside the ice chute. Closing of the bin thermostat begins the process of making ice, because the line side power now goes to the compressor, gearmotor, and if air cooled, the fan motor.
- Power is initially connected to the gearmotor through contacts 3 and 2 of the auger delay

pressure control. This causes the auger motor to start and run. At the same time, if the centrifugal switch on top of the gearmotor closes (meaning the motor is at full speed) the compressor is connected to the neutral side of the power supply, and the compressor begins to run.

- As the compressor runs, the low side or suction pressure begins to fall, when it reaches a preset point, the contacts within it move, opening 3 and 2, then closing 1 and 2. The power for the gearmotor is then connected to a point in the series circuit ahead of the low pressure control, the low water pressure control and the bin thermostat, so that if any of these open, the gearmotor will continue to run, pushing ice out of the evaporator.

**OPERATION: Water**

Water enters the machine through the 1/4" male flare at the rear of the cabinet, goes past the water pressure switch and then to the water reservoir which it enters through the float valve. The water then goes out the bottom of the reservoir tank to the bottom of the evaporator.

Reservoir overflow is routed to the drain. Water cooled models have a separate water circuit for the cooling water: it enters the fitting at the rear, goes to the water regulating valve, then to the water cooled condenser and down the drain.

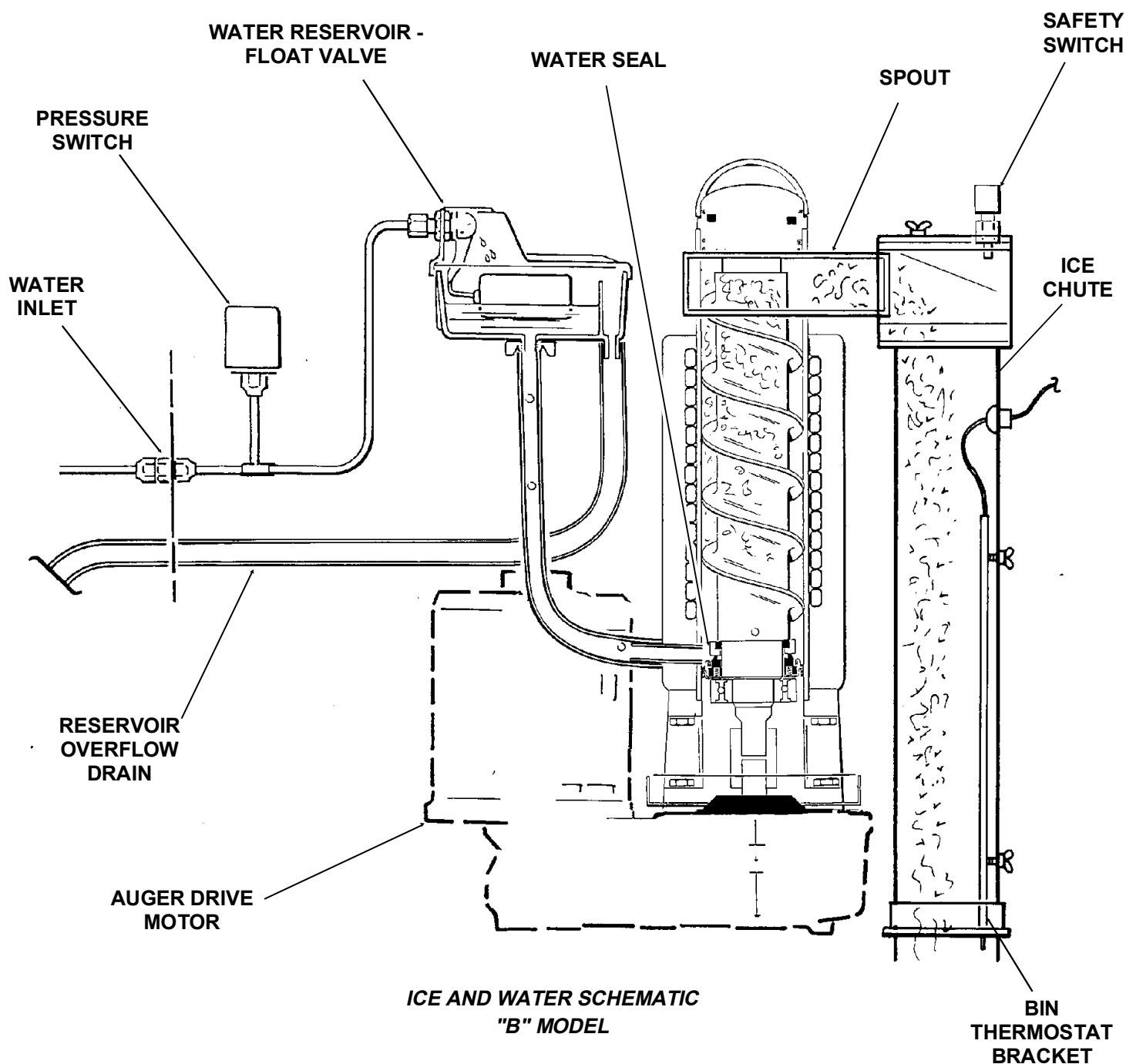

**ICE AND WATER SCHEMATIC  
"B" MODEL**

# MF400

## OPERATION: Refrigeration

---

Beginning at the compressor, the refrigerant is compressed into a high temperature gas. The discharge line directs this gas to the condenser. At the condenser (air or water cooled) the gas is cooled by either air or water and it then condenses into a liquid. This high pressure liquid then goes through the liquid line to the capillary tube. The capillary tube meters liquid refrigerant into the evaporator, the volume of liquid refrigerant depending upon the temperature of the evaporator; warmer evaporators get more refrigerant and colder evaporators get less.

At the evaporator, the refrigerant enters an area of relatively low pressure, where it can easily "boil off" or evaporate. As it evaporates, it absorbs heat from the evaporator and whatever is in contact with it (such as the water inside it). After the evaporator, the refrigerant, now a low pressure vapor, goes through the suction line back to compressor, where the cycle is repeated.

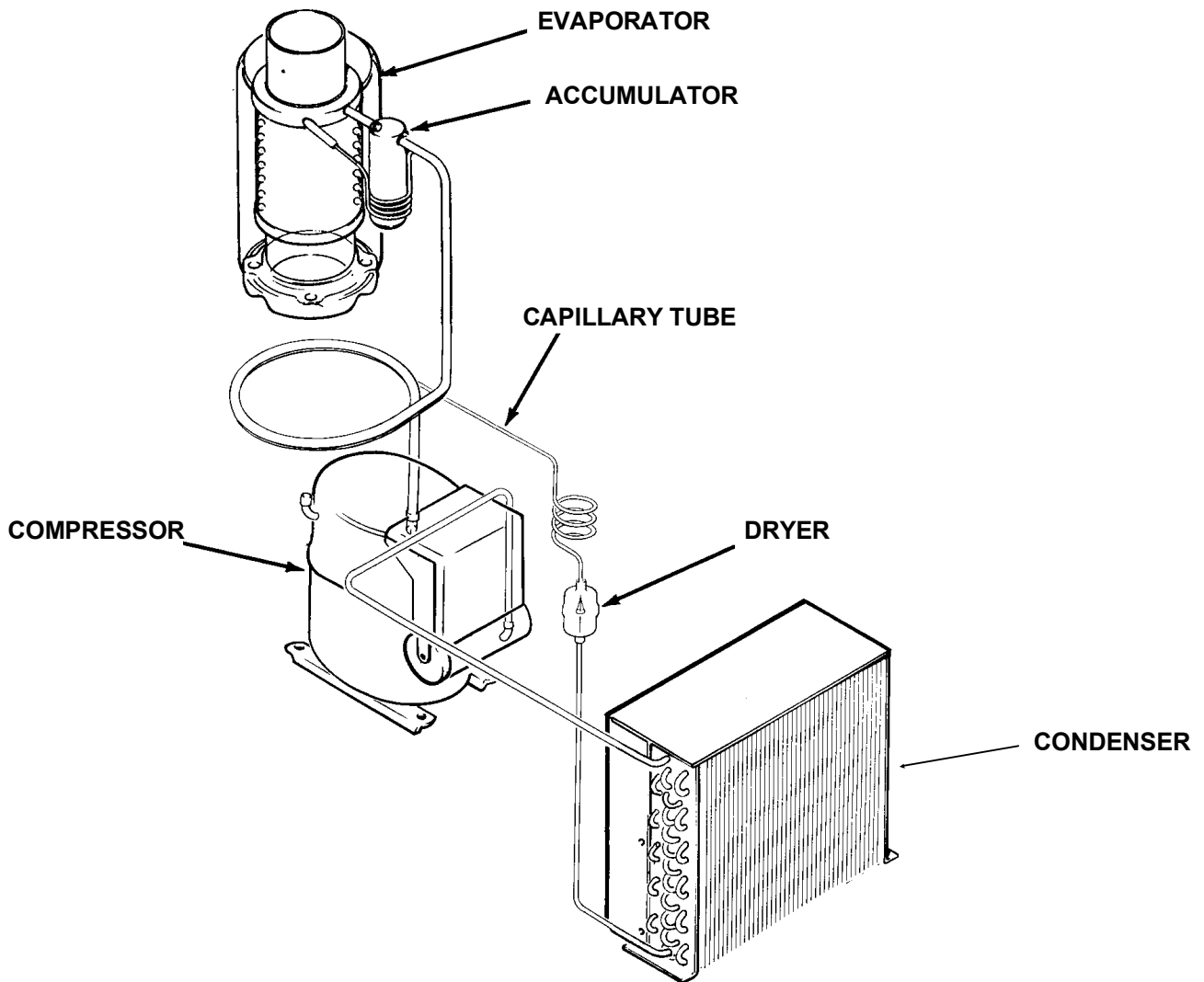

## MAINTENANCE AND CLEANING

////////////////////////////////////  
 A Scotsman Ice System represents a sizable investment of time and money in any company's business. In order to receive the best return for that investment, it MUST receive periodic maintenance.

It is the USER'S RESPONSIBILITY to see that the unit is properly maintained. It is always preferable, and less costly in the long run, to avoid possible down time by keeping it clean; adjusting it as needed; and by replacing worn parts before they can cause failure. The following is a list of recommended maintenance that will help keep the machine running with a minimum of problems.

Maintenance and Cleaning should be scheduled at a minimum of twice per year.

////////////////////////////////////  
**WARNING**  
**Electrical power will be ON when doing in place cleaning. Switch it OFF before completing the cleaning procedures.**

- ////////////////////////////////////  
**ICEMAKING SYSTEM: In place cleaning**
1. Check and clean any water treatment devices, if any are installed.
  2. Remove screws and remove the top and front panels.
  3. Move the ON-OFF switch to OFF.
  4. Open the door to the ice storage bin, and remove the ice.
  5. Remove the cover to the water reservoir and block the float up.
  6. Drain the water reservoir and freezer assembly.

////////////////////////////////////  
**WARNING**  
**Scotsman Ice Machine Cleaner contains Phosphoric and Hydroxyacetic acids. These compounds are corrosive and may cause burns. If swallowed, DO NOT induce vomiting. Give large amounts of water or milk. Call Physician immediately. In case of external contact, flush with water. KEEP OUT OF THE REACH OF CHILDREN.**

- ////////////////////////////////////
7. Prepare the cleaning solution: Mix eight ounces of Scotsman Ice Machine Cleaner with three quarts of hot water. The water should be between 90-115 degrees F.
  8. Slowly pour the cleaning solution into the water reservoir until it is full. Wait 15 minutes, then switch the master switch to ON.
  9. As the ice maker begins to use water from the reservoir, continue to add more cleaning solution to maintain a full reservoir.

10. After all of the cleaning solution has been added to the reservoir, and the reservoir is nearly empty, switch the master switch to OFF.
  11. After draining the reservoir, as in step 6, wash and rinse the water reservoir.
  12. Remove the block from the float in the water reservoir.
  13. Switch the master switch to ON
  14. Continue ice making for at least 15 minutes, to flush out any cleaning solution. Check ice for acid taste - continue icemaking until ice tastes sweet.
- ////////////////////////////////////  
**WARNING**  
**DO NOT USE any ice produced from the cleaning solution.**  
**Be sure no ice remains in the bin.**
- ////////////////////////////////////
15. Remove all ice from the storage bin.
  16. Add warm water to the ice storage bin and thoroughly wash and rinse all surfaces within the bin.
  17. Sanitize the bin interior with an approved sanitizer using the directions for that sanitizer.
  18. Replace the top and the front panels.

# MF400

## MAINTENANCE AND CLEANING

////////////////////WARNING////////////////////

**Disconnect electrical power and shut off the water before beginning.**

////////////////////

In some areas, the water supply to the ice maker will contain a high concentration of minerals, and that will result in an evaporator and auger becoming coated with these minerals, requiring a more frequent removal than twice per year. If in doubt about the condition of the evaporator and auger, the auger can be removed so the parts can be inspected.

Note: Water filters can filter out suspended solids, but not dissolved solids. "Soft" water may not be the complete answer. Check with a water treatment specialist regarding water treatment.

***For more information on removal of these parts, see REMOVAL AND REPLACEMENT.***

### **To Inspect The Top Bearing:**

1. Remove permagum and two screws from the side of the evaporator.
2. Remove the snap ring and cap, and remove the bolt from the ice breaker and auger assembly to separate the ice breaker assembly from the auger. Pull the ice breaker with bearing out of the top of the evaporator: the auger should stay in the evaporator.

The bearings may be inspected for rust, wear, and roughness. Reverse to reassemble.

### **To Inspect the Auger:**

1. Remove permagum and two screws from the side of the evaporator.
2. Pull up on cap hook located in the top of the freezer assembly to remove the ice breaker assembly, auger, and the top portion of the water seal.
3. Inspect the auger and the water seal. Clean the auger of any mineral build up. Scotsman Ice Machine Cleaner and a scouring pad work well to clean the auger. **DO NOT USE** steel wool.

////////////////////WARNING////////////////////

**Scotsman Ice Machine Cleaner contains Phosphoric and Hydroxyacetic acids. These compounds are corrosive and may cause burns. If swallowed, DO NOT induce vomiting. Give large amounts of water or milk. Call Physician immediately. In case of external contact, flush with water. KEEP OUT OF THE REACH OF CHILDREN.**

////////////////////

4. Replace the water seal, see the instructions under "Removal and Replacement".

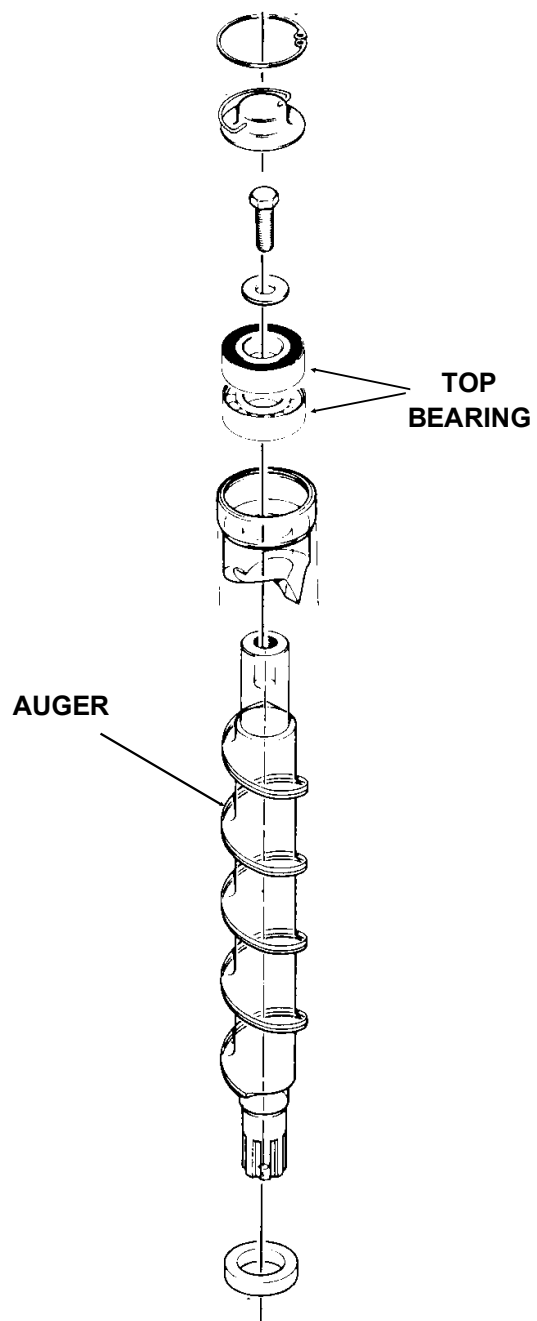

## SERVICE DIAGNOSIS: Condition - No Ice Being Produced

---

STATUS: **ICE MAKER DOES NOT OPERATE**

---

**A. Check: Voltage** to the unit, restore it if there is none. Compare to the nameplate.

---

**B. Check: The master switch**, switch ON if off.

---

**C. Check: The 3 reset switches**, (circuit board, high and low pressure): depress and release each switch. If the still does not start, check: the spout switch; the high and the low side pressures.

---

**D. Check the low pressure cut out**, if closed, go to **E**; if it is open, it could be due to:

- Low refrigerant charge
- The auger not turning
- Restricted system

1. Check the low side pressure, the low pressure cut out opens at pressure below 4 psig.

If open, reset and:

a. Check if the **auger** is turning, if it is not, remove the **gearbox** and:

Check for internal damage, repair and replace in the machine.

b. Check for low charge, add some refrigerant, if the unit will operate, (normal low side pressure being about 13 psig) stop and look for a leak, repair, replace the drier, evacuate, and weigh in the nameplate charge. If, with added charge, the unit does **not** operate:

Check for a restricted system, replace the drier, evacuate, and weigh in a nameplate charge.

---

**D. On Water Cooled**, check the **high pressure cut out**, if closed, go to **E**; if open:

1. The pressure control opens at 250 psig. **Check** the high side pressure, reset the control, and observe: that water soon begins to flow from the condenser drain;

If the unit trips out on

pressures below 250 psig, replace the control. If the pressures rise above the trip out point, and the unit shuts down:

a. Check for adequate water flow on through the condenser, if adequate, clean the interior of the condenser. If the pressures are still too high replace the water regulating valve.

---

**E. Check the spout switch**. It opens from excess pressure of ice inside the ice chute: this should only happen when the machine does not shut off when the ice storage bin is full. This switch will reset when the ice melts,

---

**F. Check the water pressure to the unit**. The machine will not run if there is not enough water pressure.

1. Restore/adjust water supply.

# MF400

## SERVICE DIAGNOSIS: Condition - No Ice Being Produced

---

### **STATUS: ICE MAKER DOES NOT OPERATE**

---

H. Check: The gear **motor** , if it will not run, the compressor will not run. If no power to it:

Check that the Bin Thermostat is closed. If open, with no ice on it, replace the bin thermostat.

Check that the Auger Delay contacts 3-2 are closed. If open, and the low side (suction) pressure is over 32 PSIG, replace the auger delay pressure control.

If power to the auger drive motor, and it does not run, replace the auger drive motor.

### **STATUS: GEARMOTOR OPERATES, COMPRESSOR DOES NOT**

---

**A.** Check the auger drive motor centrifugal switch. If, when the drive motor is running, the compressor has no power, and all of the above switches have been checked, replace the centrifugal switch.

---

### **B. Check the compressor**

1. Check the compressor start relay.

2. Check the start capacitor.

3. Check the windings of the compressor for open windings or shorts to ground.

Replace those items found defective.



## REMOVAL AND REPLACEMENT

### Ice Breaker and Auger Removal

1. Remove permagum and two screws from the side of the evaporator.
2. Pull up on cap hook located in the top of the freezer assembly to remove the ice breaker assembly, auger, and the top portion of the water seal.
3. Remove the snap ring and cap, and remove the bolt from the ice breaker and auger assembly to separate the ice breaker assembly from the auger. The bearings may be replaced or the ice breaker and bearings may be replaced as an assembly.

### Water Seal Installation

Inspect the water seal in it's package. Do not use if mating surfaces are scratched or cracked.

1. Remove auger, unbolt evaporator from adaptor stand. Drive out old bottom bearing and water seal from the top down.
2. Remove the old rotating half of the water seal from the auger and clean the auger at the seal mounting area.

3. Apply Scotsman part number 19-0529-01 food grade sealant to the auger shoulder before pushing on the water seal. Place just enough sealant onto the shoulder of the auger, so that when the water seal is placed on the auger, the gap between the auger shoulder and the water seal is completely filled with the sealant.
4. Clean the inside of the evaporator at the bottom bearing and water seal mounting area. Lubricate the outside edge of the stationary seal with water.
5. Carefully push the stationary part of the water seal up into the bottom of the evaporator. It must go in straight and must not be pushed in beyond 1/4" past the bottom of the evaporator.

6. Install a new bottom bearing, push it into the evaporator under the new water seal. It must be pushed in straight, but do not push it in past 1/8" from the bottom of the evaporator tube.

7. Mount the adaptor stand to the bottom of the evaporator. Hand tighten the three cap screws until the stand flange is tight against the bottom of the evaporator. Hand tighten the three cap screws until the stand flange is tight against the bottom bearing. Then, tighten the screws in a rotating pattern to insure proper alignment.

8. The top bearing should also be changed at this time. Be sure to mount the top breaker/bearing assembly onto the auger before installing the auger into the evaporator tube.

9. Lower the auger into the evaporator, twist it to engage the splines of the coupling. Secure the breaker and bearing to the evaporator tube with the two screws removed in step 1 of "Ice Breaker and Auger Removal". Test the unit.

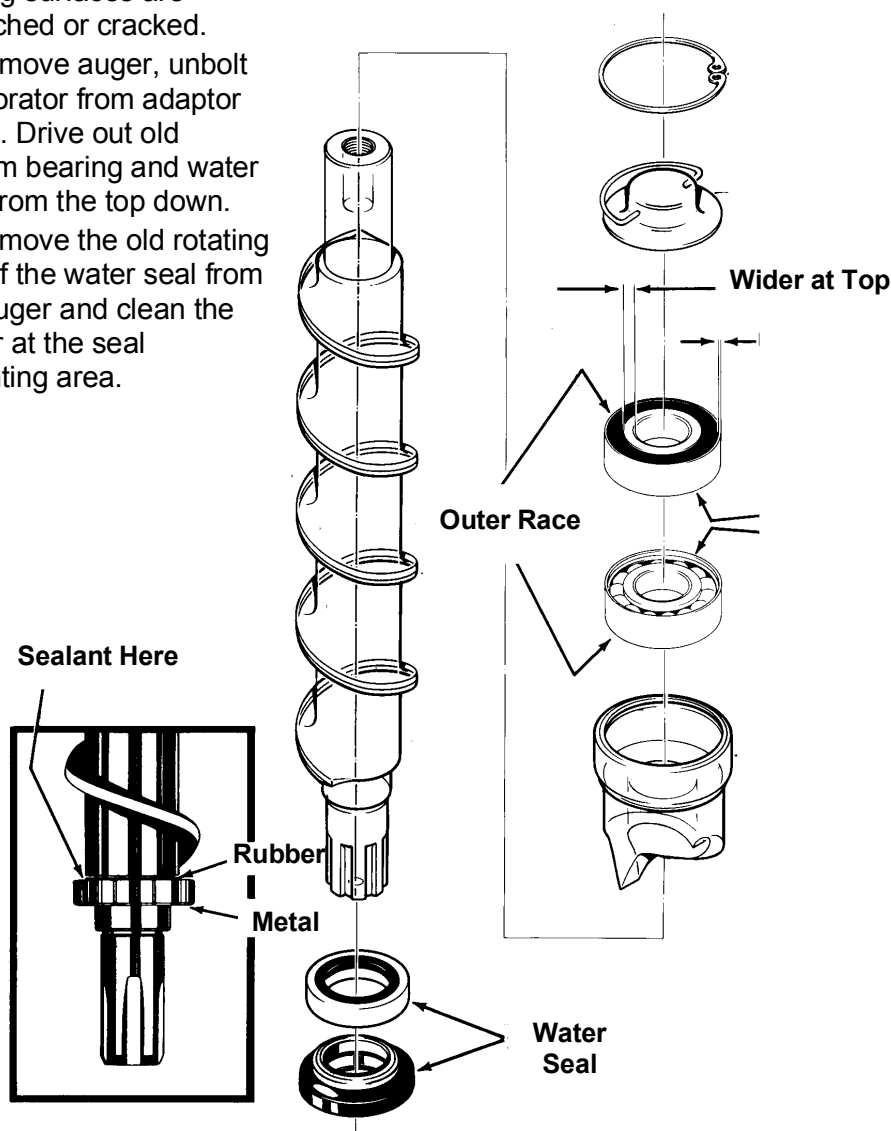

# MF400

## REMOVAL AND REPLACEMENT: Gearmotor Assembly

---

### Rebuilding The Gearmotor Assembly

Drive Motor Parts:

To replace the centrifugal switch and mechanism or the motor winding or the motor rotor, removal of the gearbox assembly is not necessary.

1. Disconnect electrical power.
2. Remove the cover from the top of the centrifugal switch assembly and remove the electric wires from the microswitch. To replace just the centrifugal switch, remove two machine screws retaining the switch, and remove the switch. To replace, reverse the procedure to this point.
3. If the motor is to be removed, the next step is to remove the four screws holding down the plastic switch assembly housing and lift the housing off of the motor top.
4. Remove the centrifugal switch mechanism from the rotor by unscrewing the machine screw at the top of the rotor.
5. The motor and housing may now be removed. Lift off the motor fan housing, and pull off the plastic fan. The next part to be removed is the motor winding. Disconnect the electrical leads of the motor from its control box location and lift off the winding.
6. The rotor is all that remains of the motor in the gear motor assembly. Use a pry bar to carefully pry up the rotor. (The only thing holding it in is the tight fit of the bottom rotor bearing into the top of the gear case.) To replace any of the above parts, reverse the disassembly procedure.

### Removal of the Gearmotor Assembly

1. Remove the top and right side panel.
2. Remove the ice chute assembly.
3. Unscrew the three cap screws retaining the evaporator assembly to the gearmotor assembly.
4. Unscrew the bolts holding the gearmotor mounting plate to the ice machine chassis.
5. Remove the motor and centrifugal switch electrical leads from their connections.
6. Raise the evaporator assembly up enough that the output shaft clears the freezer adaptor.
7. Remove the gearmotor assembly from the ice machine.

### Gearcase Service

After removal of the gear motor from the unit, inspect the internal parts from this gearmotor.

1. Place the gearbox on a flat surface, covered with rags to absorb any spilled lubricant.
2. Using a punch, drive the roll pins out of the casing.
3. Remove the four cap screws on the top of the gearcase and the two under the motor.
4. Pry the two cases apart.

When inspecting the internal parts, look for:

- Condition and quantity of lubricant. (The proper oil level is near the top of the output (biggest) gear. This takes 5 oz. Use Scotsman oil, part number A25835-001.
- Bearing condition
- Gear and Shaft condition
- Woodruff key between output gear and shaft.
- Grease seals, back to back.
- Vent hole

Be sure to count and retain the spacer washers as they come out of the gearbox.

Replace the parts as required, using the part numbers found in the parts section of this manual. Replace the gears into a CLEAN bottom gearcase, after adding some grease to the bearings. Replace the spacers in the same quantity as they were removed. If no count was kept, use the numbers found in the parts list.

Note: Some bearing grease should be placed in all bearings before assembly to insure proper lubrication upon start up.

### Reassembly

1. Set top gearcase on gears and spacers and oil. Be sure O-ring is in place.
  2. Drive roll pins back into locating holes.
  3. Replace cap screws into gearcase cover, and torque at 80-90 inch pounds.
  4. Bench test the gearmotor assembly.
- Test for noise, amp draw (must not be in excess of ice maker nameplate for gearmotor) and oil leaks. Return the gearmotor assembly to the unit. Be certain all mounting surfaces are clean and reassemble to the gearmotor mounting plate. Then bolt back onto ice machine chassis.

Gearmotor Service

