

MFE400 SERVICE PARTS

This is the parts list for all MFE400 model units.
The **complete** model number must be checked,
especially when ordering electrical parts, as this
model was manufactured in 60 Hz and 50 Hz
versions.

Table Of Contents

Cabinet	2
Major Refrigeration Components	3
Water System	4
Ice Discharge Tube	5
Evaporator	6
Gearmotor	7
Control Box	8
Wiring Diagrams	9

MFE400 SERVICE PARTS

Cabinet

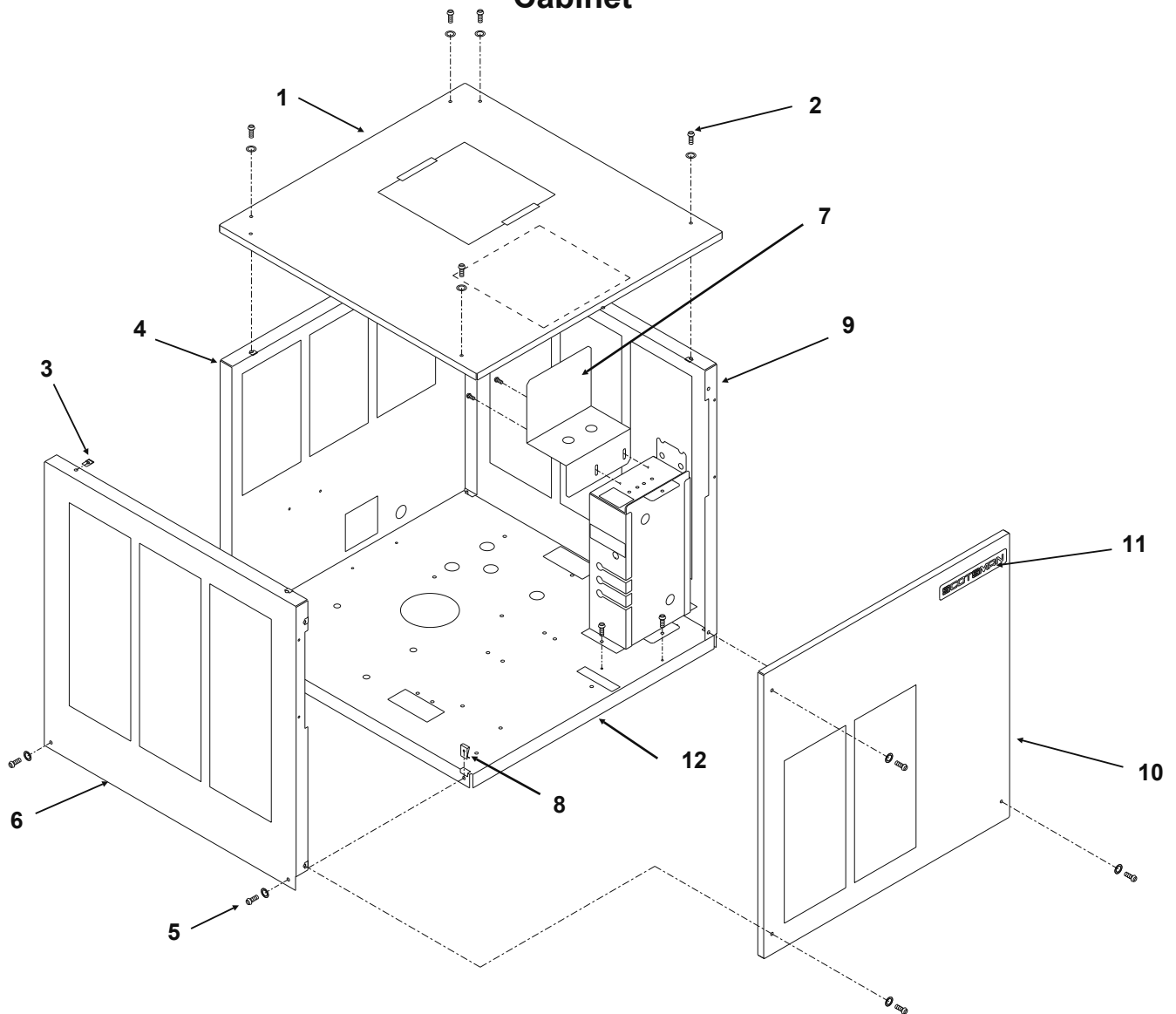

ITEM NUMBER	PART NUMBER	DESCRIPTION	ITEM NUMBER	PART NUMBER	DESCRIPTION
1	A26625-005	Top panel, sndlwd	10	A36441-001	Front panel, sndlwd
	A26625-015	Top panel, gray		A36441-015	Front panel, gray
	A26625-006	Top panel, stainless		A36441-002	Front panel, stainless
2	03-1419-09	Flat head screw	11	15-0718-01	Emblem, for sndlwd
3	03-1423-06	Speed nut		15-0808-01	Emblem, gray
4	A28048-004	Back panel, sndlwd		03-0271-00	Speed clip for
	A28048-015	Back panel, gray	emblem		
	A28048-005	Back panel, stainless	12	A36072-001	Base
5	03-1404-09	Panel Screw			
6	A26623-005	Lft side pnl, sndlwd			
	A26623-015	Lft side pnl, gray			
	A26623-006	Lft side pnl, stainless			
7	A36077-001	Reservoir bracket			
8	03-1507-00	Speed nut			
9	A26624-005	Rt side pnl, sndlwd			
	A26624-015	Rt side panel, gray			
	A26624-006	Right side panel, ss			

MFE400 SERVICE PARTS

Major Refrigeration Components

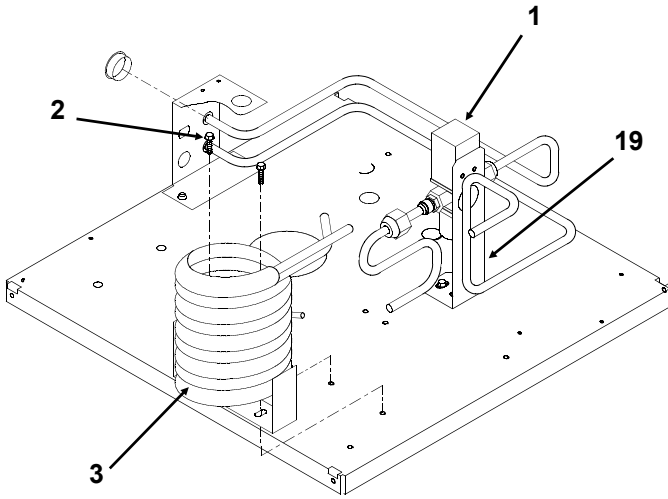

ITEM NUMBER	PART NUMBER	DESCRIPTION
1.	11-0198-02	Water reg. valve
2.	03-1645-01	Screw
3.	18-3305-25	A series water cooled condenser
	18-8871-21	B series water cooled condenser

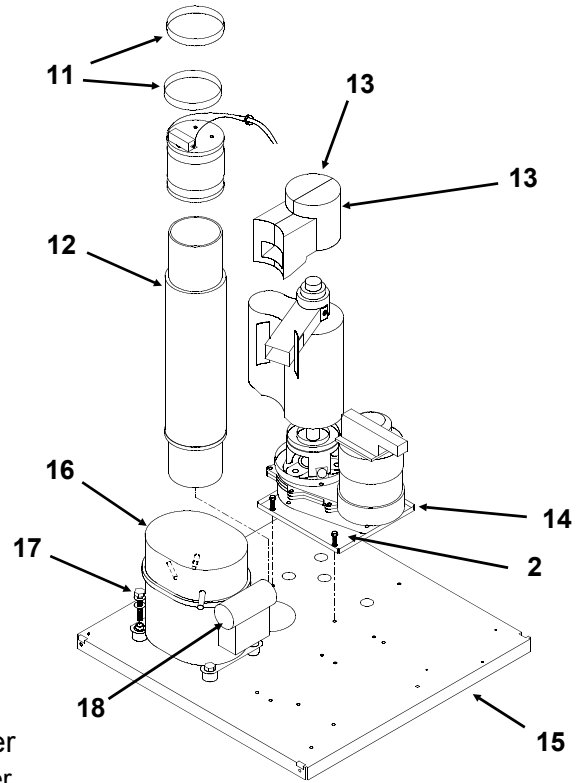

ITEM NUMBER	PART NUMBER	DESCRIPTION
11	02-0694-00	Clamp
12	05-0582-01	Ice chute
13	02-3200-01	Insulation half
	02-3200-02	Insulation half
14	A27109-001	Motor plate
15	A36072-001	Base
16	18-8741-21	60 hz compressor*
	18-8741-26	50 hz compressor*
	18-8741-27	Overload for 60 Hz
	18-8741-22	Overload for 50 Hz
17	03-1417-12	Lockwasher
	03-1408-29	Washer
	03-1405-40	Screw
	18-0108-40	Sleeve
	18-4700-28	Grommet
18	18-8741-29	60 hz start capacitor
	18-8741-24	50 hz start capacitor
	18-8741-28	60 hz start relay
	18-8741-23	50 hz start relay
19	A33990-001	Bracket
20	13-0902-01	Gasket, 30" req. order by the foot

* Includes drier.

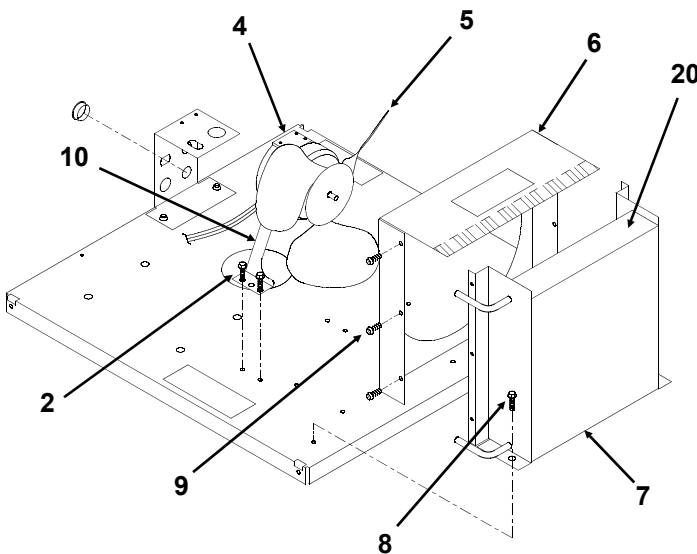

ITEM NUMBER	PART NUMBER	DESCRIPTION
4.	18-8766-21	60 hz fan motor
	12-8766-22	50 hz fan motor
5	18-3309-01	Fan blade
6	A36076-001	Fan shroud
7	18-8846-01	Air cooled condenser
8	03-1645-01	Screw
9	03-1404-08	Screw
10	18-0422-00	Fan motor bracket

MFE400 SERVICE PARTS

Water System & Misc. Refrigeration

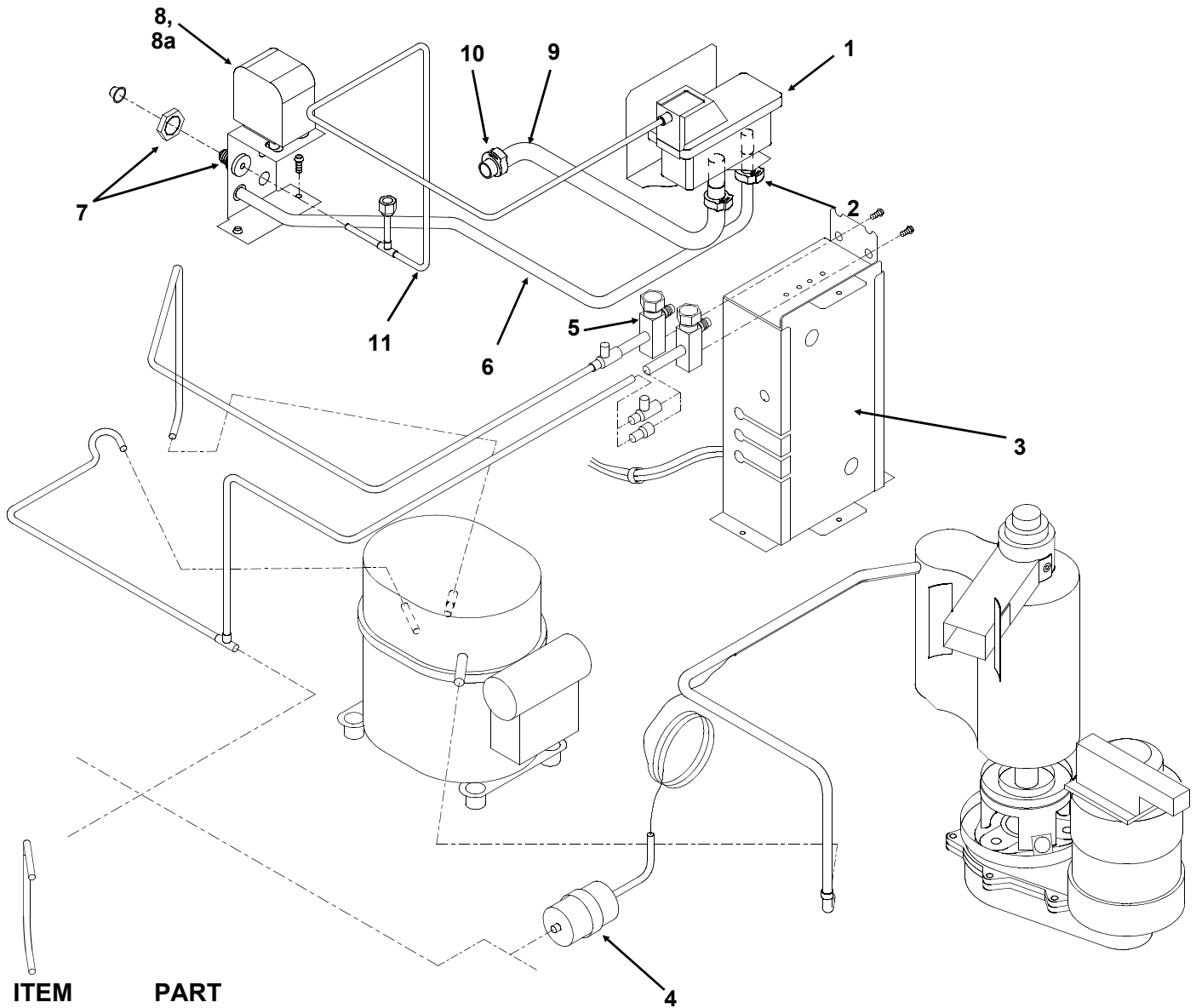

ITEM NUMBER	PART NUMBER	DESCRIPTION
1	02-2217-01	Reservoir (includes 1a)
1a	02-2217-02	Float valve
2	02-0535-01	Hose clamp
3	A36065-001	Control box cover
4	02-3319-01	Drier
5	16-0832-20	Access valve
5a	16-0832-02	Stem cap
5b	16-0832-03	Core cap
6	13-0079-03	Overflow hose, 28" req.
7	16-0835-01	Inlet fitting
	03-1394-00	Pal nut
8	11-0296-00	Water pressure cut out
	16-1046-01	Water line to switch connector
9	13-0674-09	Evaporator water inlet tube, 5" req.
10	02-0179-03	Hose clamp
11	13-0895-01	Inlet tubing, per foot. Order 3.

MFE400 SERVICE PARTS

Ice Discharge Chute

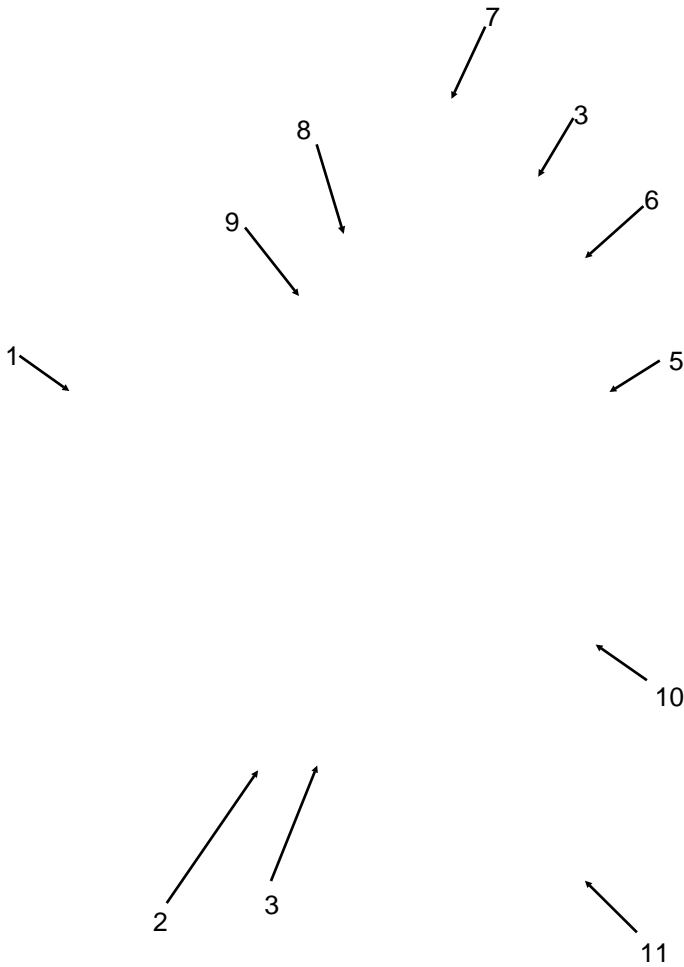

ITEM NUMBER	PART NUMBER	DESCRIPTION
1	05-0582-01	Ice Tube
	13-0848-01	Insulation (11" req.)
2	A34519-001	Bin Thermo Bracket
3	03-1587-02	Wing nut
4	no number	Spout
5	A34704-001	Cap Assy (items 3,6,4,7,11,8,9,10,11)
6	03-1407-03	Washer
7	12-1018-01	Microswitch
8	A34515-001	Speed nut
9	03-1403-09	Screw
10	A34700-001	Plate
11	A34976-020	Switch plate & bracket
12	02-3207-01	Upper spacer
13	02-3207-02	Lower spacer

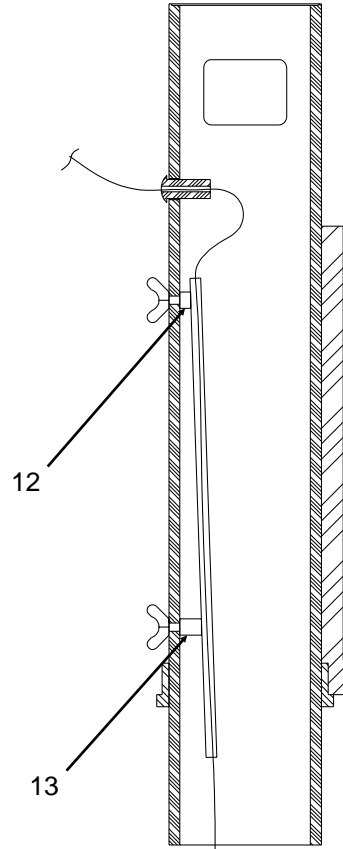

MFE400 SERVICE PARTS

Evaporator

ITEM NUMBER	PART NUMBER	DESCRIPTION
1	02-4404-02	Threaded cap - grey
2	03-0758-00	Screw
3	02-4535-01	Top bearing, w/thrust washer - for updated units*
4	02-4575-21	Breaker kit, includes items 1, 3, 4a, 4b, 7 & 7a*
4a	13-0617-16	O-Ring (inside)
4b	13-0617-37	O-Ring, outside of breaker
5	02-4600-02	Auger - for updated units*
6	A36098-020	Evaporator
7	03-1417-07	Washer
7a	03-1403-46	Screw
8	02-4599-21	Water Seal
9	02-0417-21	Lower Bearing
10	03-1505-00	Gasket
11	08-0595-01	Adapter
12	03-1405-38	Cap Screw (3)
13	03-1420-01	Cap screw
14	03-1410-04	Washer (3)
15	A29915-002	Spline Coupling
16	02-4578-02	Auger and bearing kit

Includes items 1, 2, 4, 4a, 4b, 5, 7, 7a, 8, and 9

17 19-0662-02 Top bearing grease, 13 oz tube

Note: Use about 1 oz per bearing. Lightly coat bearing surfaces, throughly grease thrust portion of bearing (horizontal needles).

* Updated units have new auger and top breaker and bearing.

Update available beginning Feb. 2010. Updated units have grey cap. Non-updated units require auger kit item 16 when replacing top bearing or auger.

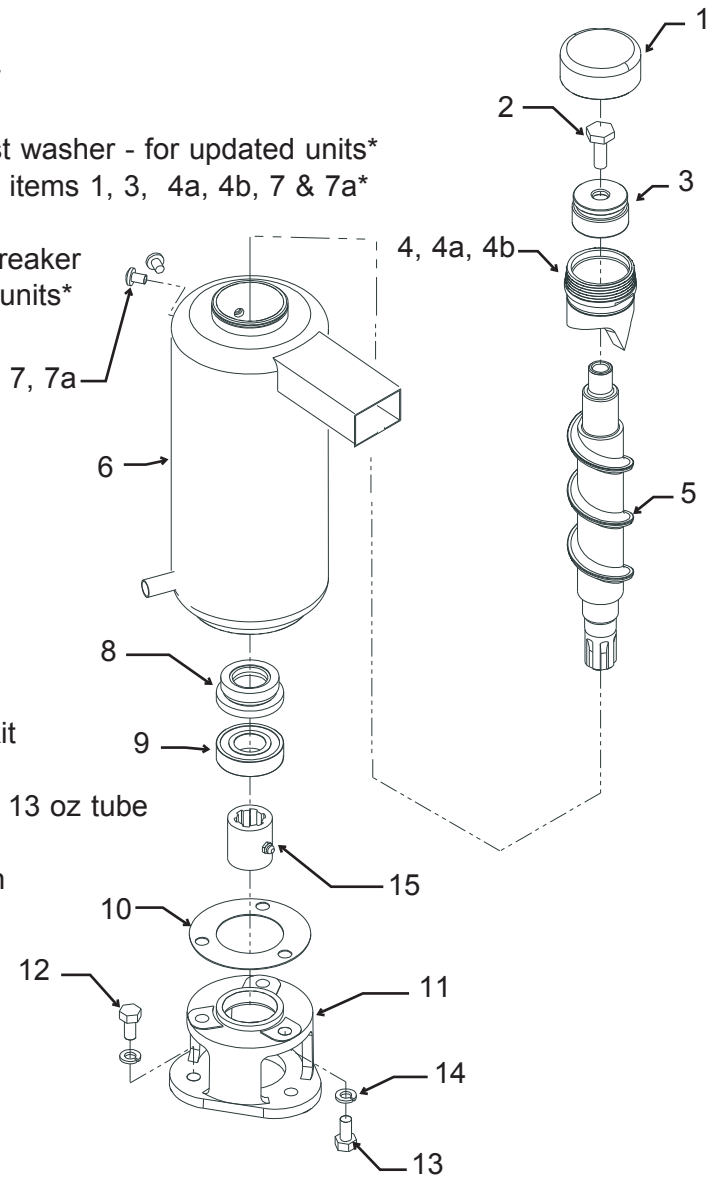

MFE400 SERVICE PARTS

Gearmotor

* Motor kit includes items 30, 29, 28, 27, 25

** Does not apply to 02-4399-21. 02-4398-21 includes all non-motor items.

ITEM NUMBER	PART NUMBER	DESCRIPTION
1.	12-2059-01	Switch
2.	A27895-001	Housing
3.	A27494-001	Centrifugal Sw. Kit
4.	03-1403-77	Screw
5.	A30579-001	Shaft and Actuator
6.	03-1408-36	Washer
7.	02-1503-00	Grease seal
	13-0941-01	Water shed, not shown
8.	03-1408-21	Washer**
9.	03-1408-04	Washer**
10.	02-2445-01	Output shaft**
11.	03-1515-03	Retaining ring
12.	03-1602-01	Woodruff Key**
13.	02-2444-01	Output gear**
14.	02-1505-00	O-ring**
	13-0947-01	Gasket for 02-4399
15.	03-0774-11	Roll pin**
16.	A28166-001	Gear Case
17.	03-1408-39	Washer
18.	03-1408-40	Washer shim
19.	02-2439-01	2nd gear & 3rd pinion
20.	03-1408-41	Washer
21.	03-1408-38	Washer
22.	02-2438-01	First gear & 2nd pinion
23.	A28165-021	Gear box cover
24.	02-3969-20	Grease seal
25.	02-1501-00	Bearing
26.	03-1408-08	Washer
27.	no number, part of item 28	
28.	A37707-021	Motor kit*, 115/60
	A38501-001	Motor kit*, 230/50
29.	A28168-001	Fan
30.	A38487-001	Motor Housing with bearing
31.	A32379-027	Oil - 16 oz.
		Note: correct oil charge is 5 oz.
32.	02-4399-21	115 v, 60 hz Complete Gear Motor Assembly
	02-4399-24	50 hz. complete gear motor assembly
	02-4398-21	Gear and case kit,

complete without motor.

* Motor kit includes rotor, stator, fan, housing and bearings

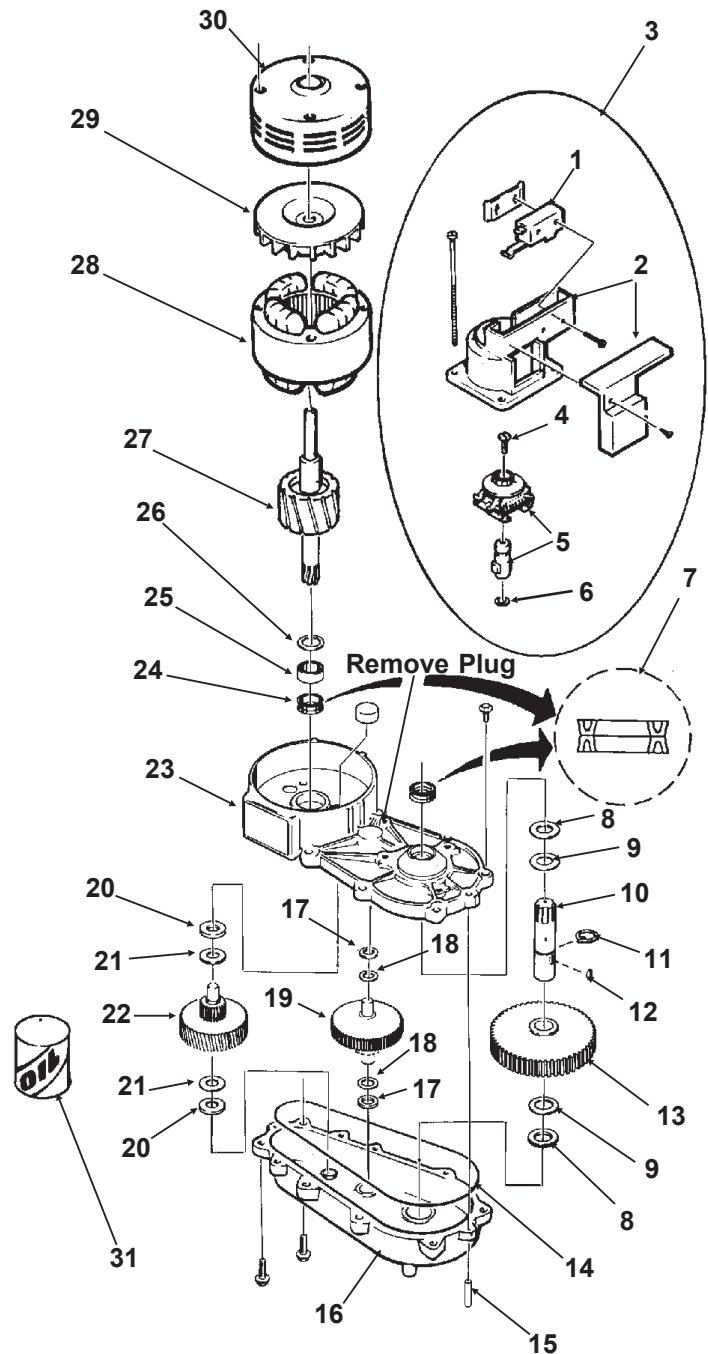

MFE400 SERVICE PARTS

Control Box

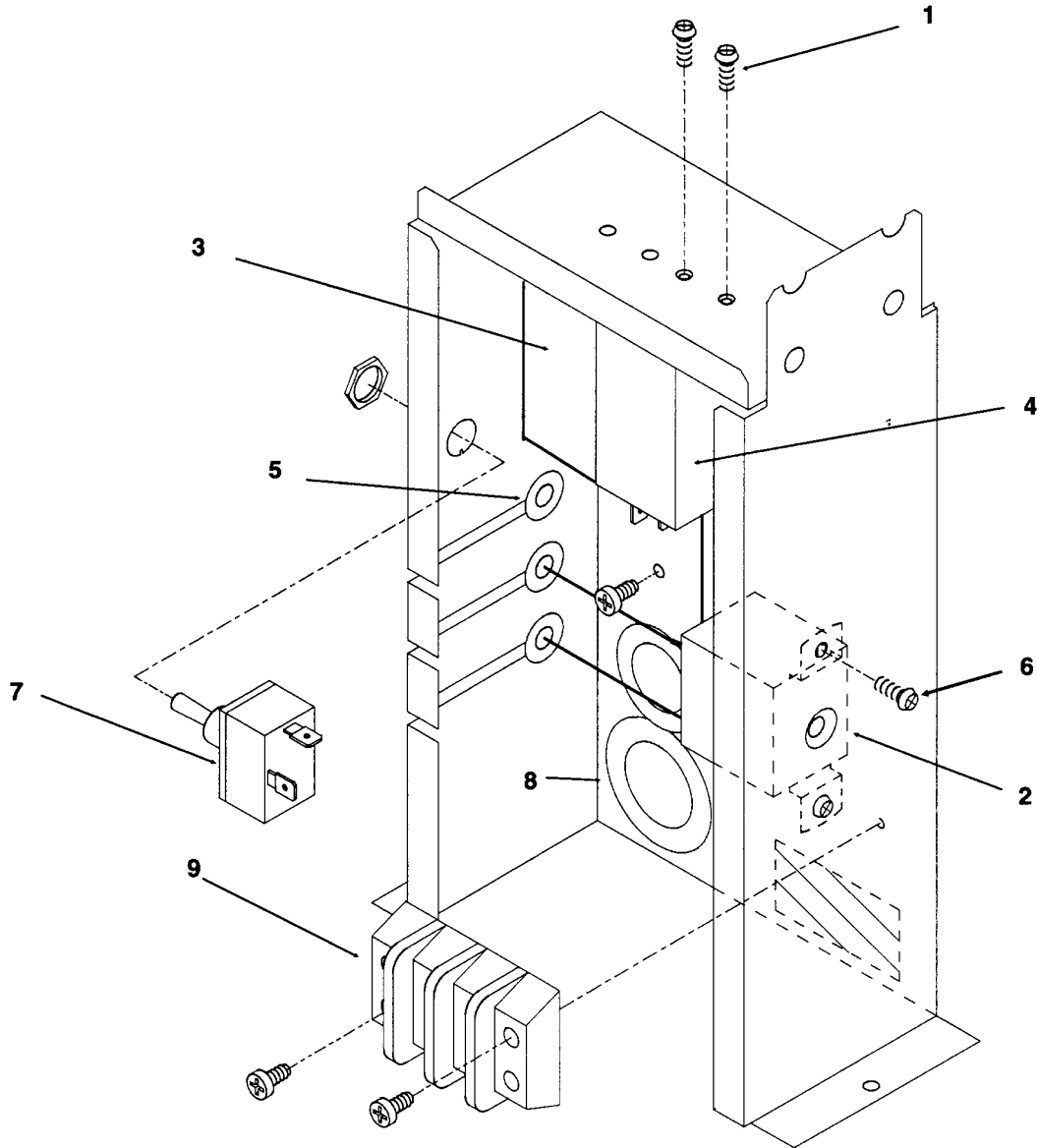

ITEM NUMBER	PART NUMBER	DESCRIPTION
1.	03-1403-02	Mounting Screw
2.	11-0354-20	Bin Thermostat
3.	11-0388-22	High pressure control, (w.c. only)
4.	11-0402-21	Auger Delay Control
5.	13-0557-00	Grommet
6.	03-1407-17	Screw
7.	12-0426-01	Toggle switch
8.	12-1213-12	Snap Bushing
9.	12-0813-04	Terminal board

MFE400 SERVICE PARTS

WIRING DIAGRAM Air Cooled

A36452-001

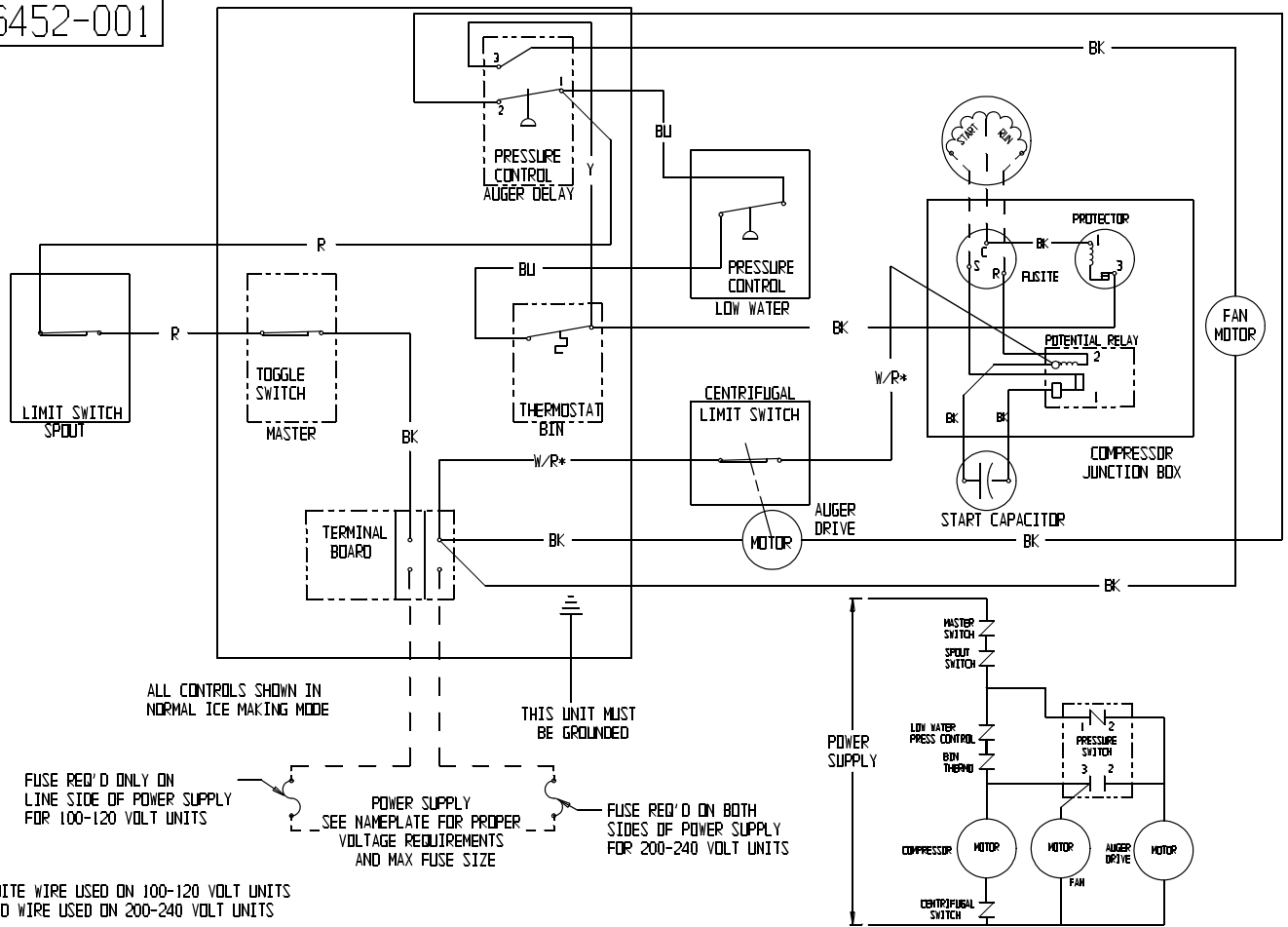

MFE400 SERVICE PARTS

WIRING DIAGRAM Water Cooled

A36453-001

