

N0422, F0522, N0622, F0822, N0922, F1222, N1322, F1522

Service Parts

This is the illustrated service parts list for the N0422, F0522, N0622, F0822, N0922, F1222, N1322 and F1522 air cooled, water cooled or remote air cooled ice machine heads.

Several models are listed together, be sure to select the correct part based on the complete model number, including voltage.

N0622 and F0822 compressor changed in 2011.

Water reservoir and related parts changed June 2012.

N0922 & F1222 compressor change in April, 2014.

F0522, N0422, F0822 and N0622 E Series water regulation valve setpoint changed to 230 PSI on water cooled units.

Prodigy Plus D Series began Dec 2014, E Series began in Aug of 2017

Voltage codes:

- -1 = 115/60/1
- -32 = 208-230/60/1
- -3 = 208-230/60/3
- -6 = 230/50/1

Contents

Exterior, N0422, F0522, N0622, F0822 A or B Series	Page 2
Exterior, N0922, F1222, N1322, F1522 A or B Series	Page 3
Exterior, N0422, F0522, N0622, F0822 D or E Series	Page 4
Exterior, N0922, F1222, N1322, F1522 D or E Series	Page 5
Interior Cabinet, Water, and Chute Systems - Clear Reservoir Cover	Page 6
Interior Cabinet, Water, and Chute Systems - White Reservoir Cover & D or E Series	Page 7
Refrigeration Condensing, Air Cooled	Page 8
Condenser Fan Motor System - N0422, F0522, N0622, F0822	Page 9
Condenser Fan Motor System, N0922, F1222, N1322, F1522	Page 10
Refrigeration Condensing, Water Cooled	Page 11
Refrigeration Condensing, Remote Cooled	Page 12
Remote Condenser - ERC111 or ERC311	Page 13
Nugget Evaporator System, N0422, N0622, N0922, N1322	Page 14
Evaporator System, Flakers F0522, F0822, F1222, F1522	Page 15
Gear Reducer and Motor	Page 16
Electrical & Control Box	Page 17
Compressors	Page 18
Compressor Mounting Hardware	Page 18
Crankcase Heaters	Page 18
Wiring Diagram N0422 and F0522 A Series	Page 19
Wiring Diagram N0422 and F0522 D Series	Page 30

N0422, F0522, N0622, F0822, N0922, F1222, N1322, F1522

Service Parts

Exterior, N0422, F0522, N0622, F0822 A or B Series

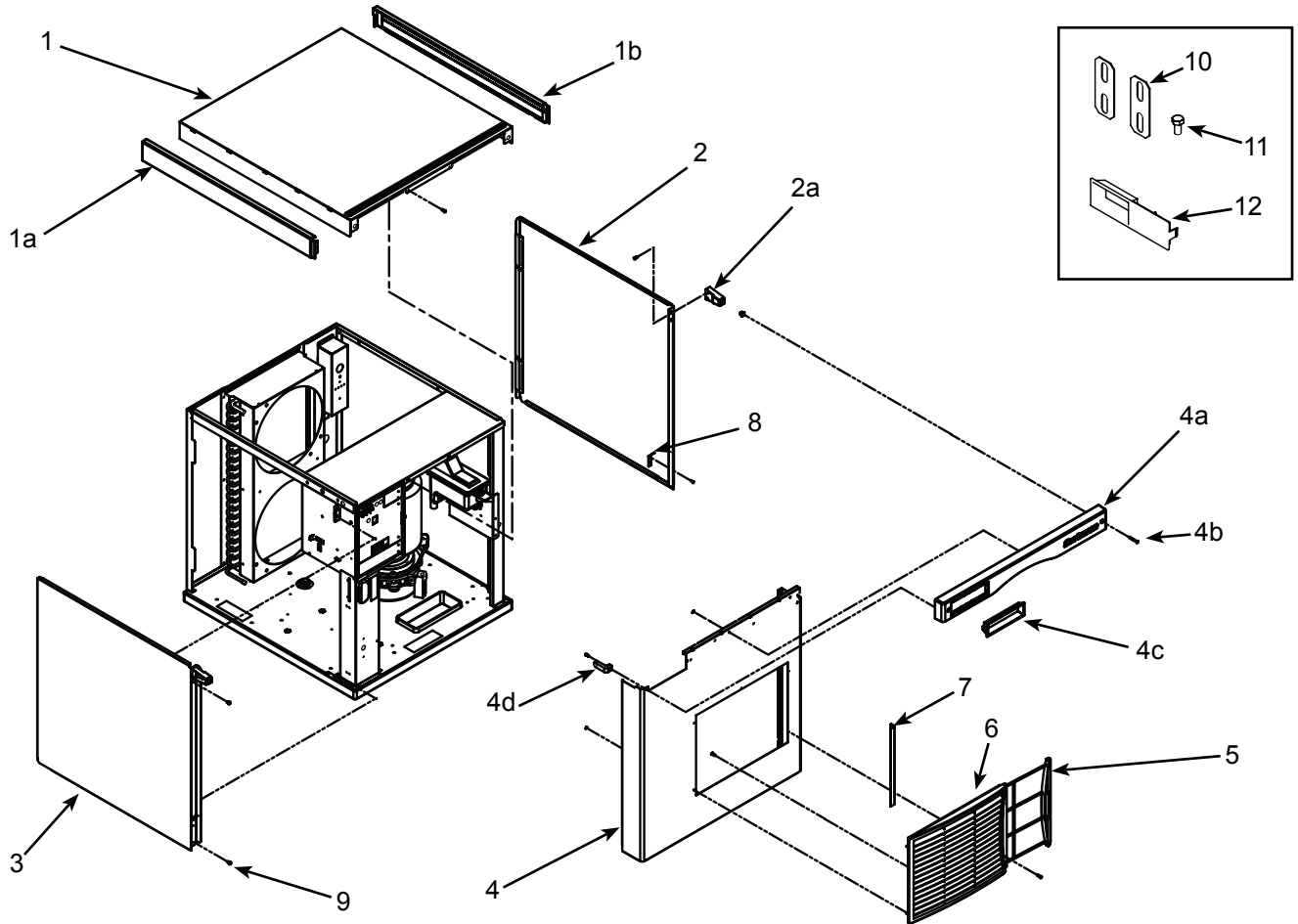

Item Number	Part Number	Description
1	A39579-021	Top panel
1a	02-4221-01	Left trim strip*
1b	02-4221-02	Right trim strip*
2	A39445-021	Right side panel
2a	02-4215-01	Screw receptacle
side panel includes items 2a and 8		
3	A39444-021	Left side panel, AC
	A39444-022	Left side panel, WC, RC
side panel includes items 2a and 8		
4	A39443-021	Front panel, AC
front panel includes items 4a, 4b, 4c, 5, 6, 7		
	A39443-022	Front panel, WC, RC
front panel includes 4a, 4b, 4c		
4a	02-4214-01	Trim strip
4b	03-1735-03	Screw
4c	02-4284-01	Bezel
4d	02-4216-01	Gusset***
5	02-4212-01	Air filter
6	02-4224-01	Louver bracket
7	A39238-001	Filter bracket
8	A39571-001	Clip
9	03-1404-12	Screw
10	A30911-015	Machine straps
11	03-1405-15	Screw
12	02-4284-02	Bezel, partial window**

* Side trim strips discontinued mid 2011

** Item 12 discontinued from production 2/9/2012.

***Gusset discontinued May 2013.

N0422, F0522, N0622, F0822, N0922, F1222, N1322, F1522

Service Parts

Exterior, N0922, F1222, N1322, F1522 A or B Series

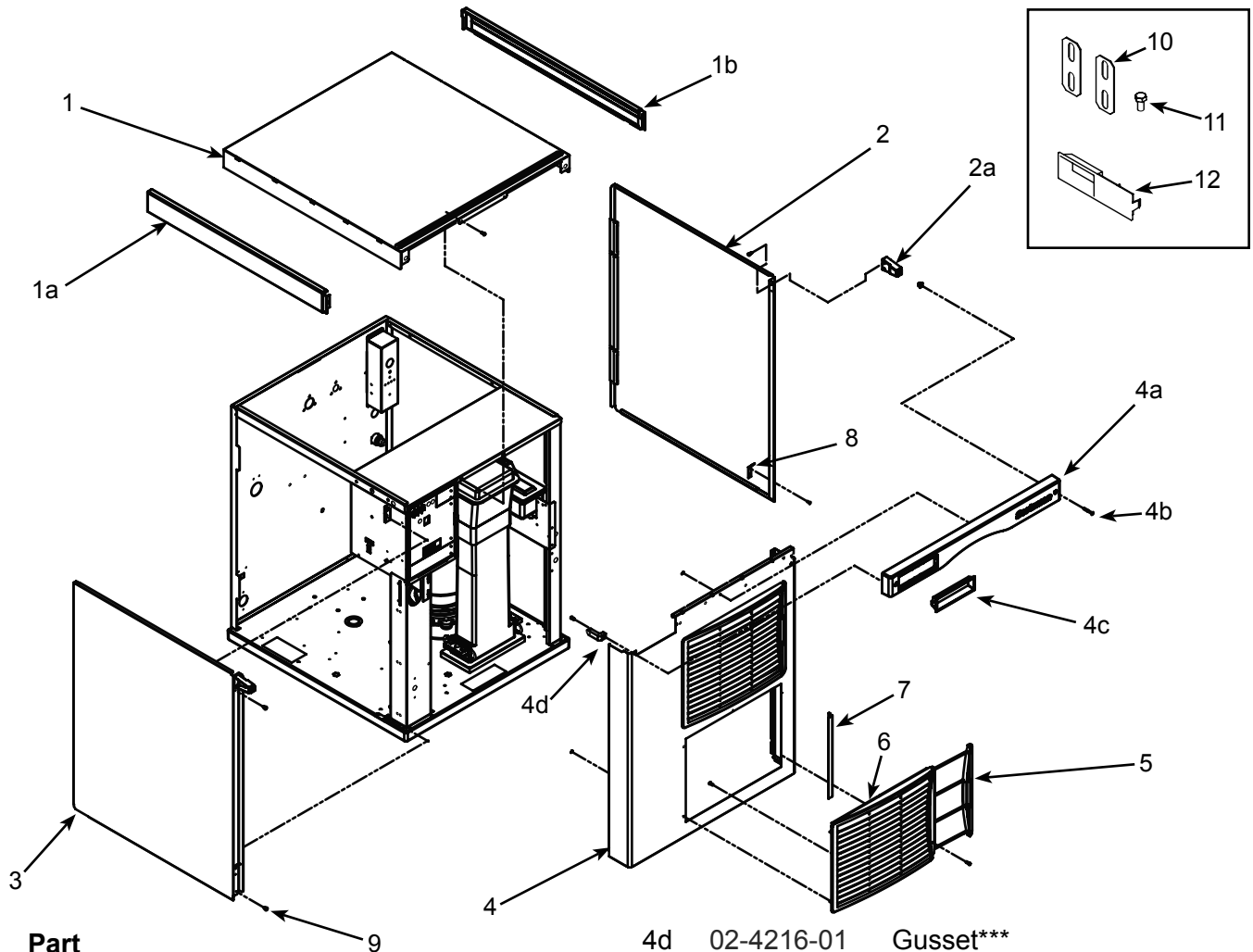

Item Number	Part Number	Description
1	A39579-021	Top panel
1a	02-4221-01	Left trim strip*
1b	02-4221-02	Right trim strip*
2	A39445-022	Right side panel
2a	02-4215-01	Screw receptacle
side panel includes items 2a and 8		
3	A39444-023	Left side panel, AC
	A39444-024	Left side panel, WC, RC
side panel includes items 2a and 8		
4	A39443-023	Front panel, AC
front panel includes items 4a, 4b, 4c, 5, 6, 7		
	A39443-024	Front panel, WC, RC
front panel includes 4a, 4b, 4c		
4a	02-4214-01	Trim strip
4b	03-1735-03	Screw
4c	02-4284-01	Bezel

4d	02-4216-01	Gusset***
5	02-4212-01	Air filter
6	02-4224-01	Louver bracket
7	A39238-001	Filter bracket
8	A39571-001	Clip
9	03-1404-12	Screw
10	A30911-015	Machine straps
11	03-1405-15	Screw
12	02-4284-02	Bezel, partial window**

* Side trim strips discontinued mid 2011

** Item 12 discontinued from production 2/9/2012.

*** Gusset discontinued May 2013

N0422, F0522, N0622, F0822, N0922, F1222, N1322, F1522

Service Parts

Exterior, N0422, F0522, N0622, F0822 D or E Series

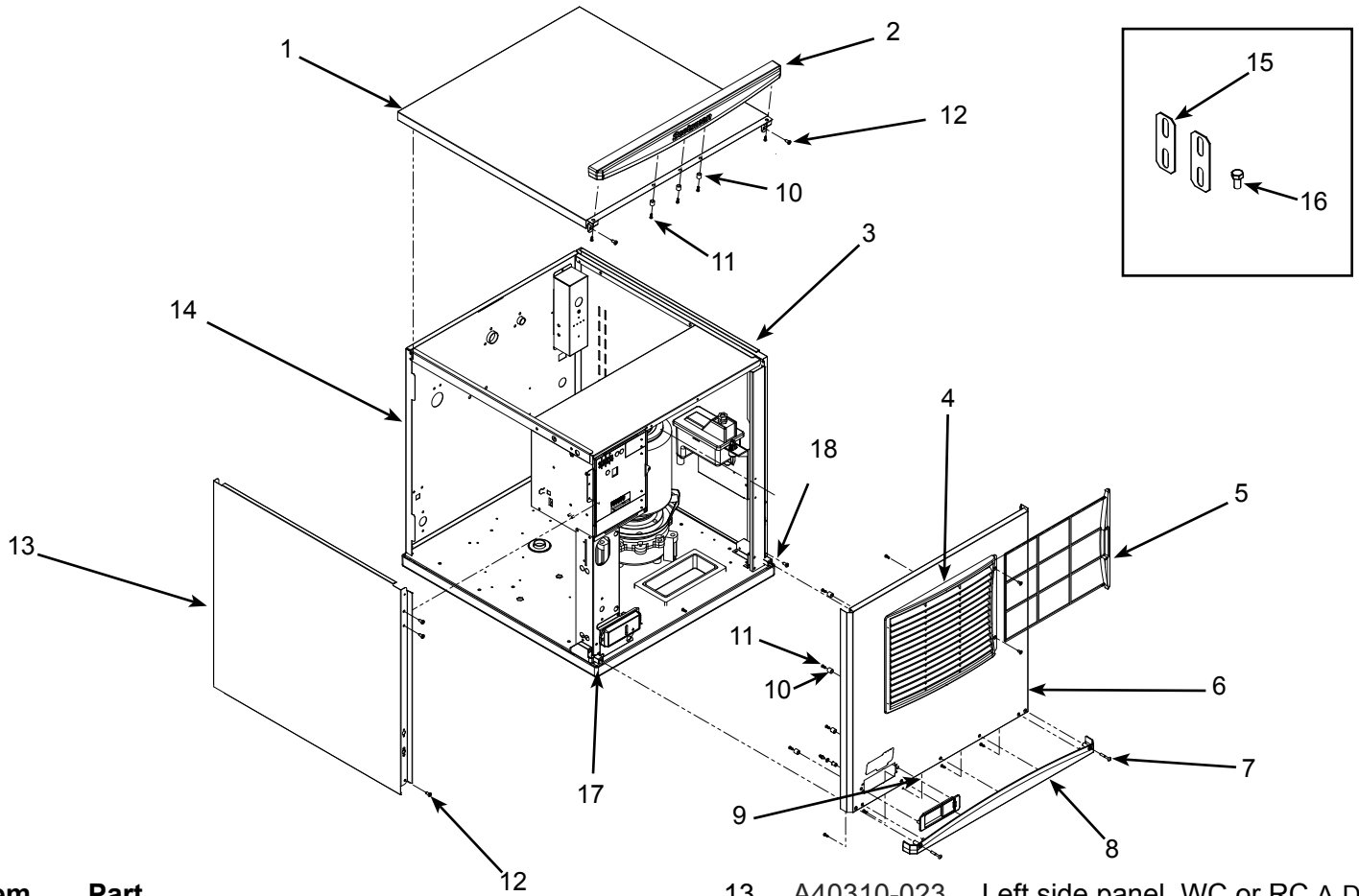

Item Number	Part Number	Description
1	A40309-022	Top panel, includes item 2
2	02-4819-02	Trim strip
3	A40335-021	Right side panel
4	02-4224-03	Louvers
5	02-4212-03	Air filter
6	A40308-025	Front panel, AC includes items 4, 5, 7, 8 and 9
6a	A40308-026	Front panel, WC or RC. Includes items 4, 5, 7, 8 and 9
7	03-1735-03	Screw
8	02-4820-02	Tim strip
9	02-4821-02	Bezel, includes standard door
9a	02-4822-01	Door, bezel with handle
9b	02-4822-02	Door, bezel secure
10	02-4824-01	Spacer
11	03-3836-02	Screw
12	03-1404-10	Screw
13	A40310-023	Left side panel, WC or RC A-D series
	A40310-021	Left side panel, WC or RC E series
	A40310-021	Left side panel, AC A-D series,
	A40310-023	Left side panel, AC E series
14	A39191-001	Back panel, WC or RC
15	A30911-015	Machine straps
16	03-1405-15	Screw
17	02-4823-21	*Panel mount kit, left
18	02-4823-22	*Panel mount kit, right
		*Includes both screw receptacles

N0422, F0522, N0622, F0822, N0922, F1222, N1322, F1522

Service Parts

Exterior, N0922, F1222, N1322, F1522 D or E Series

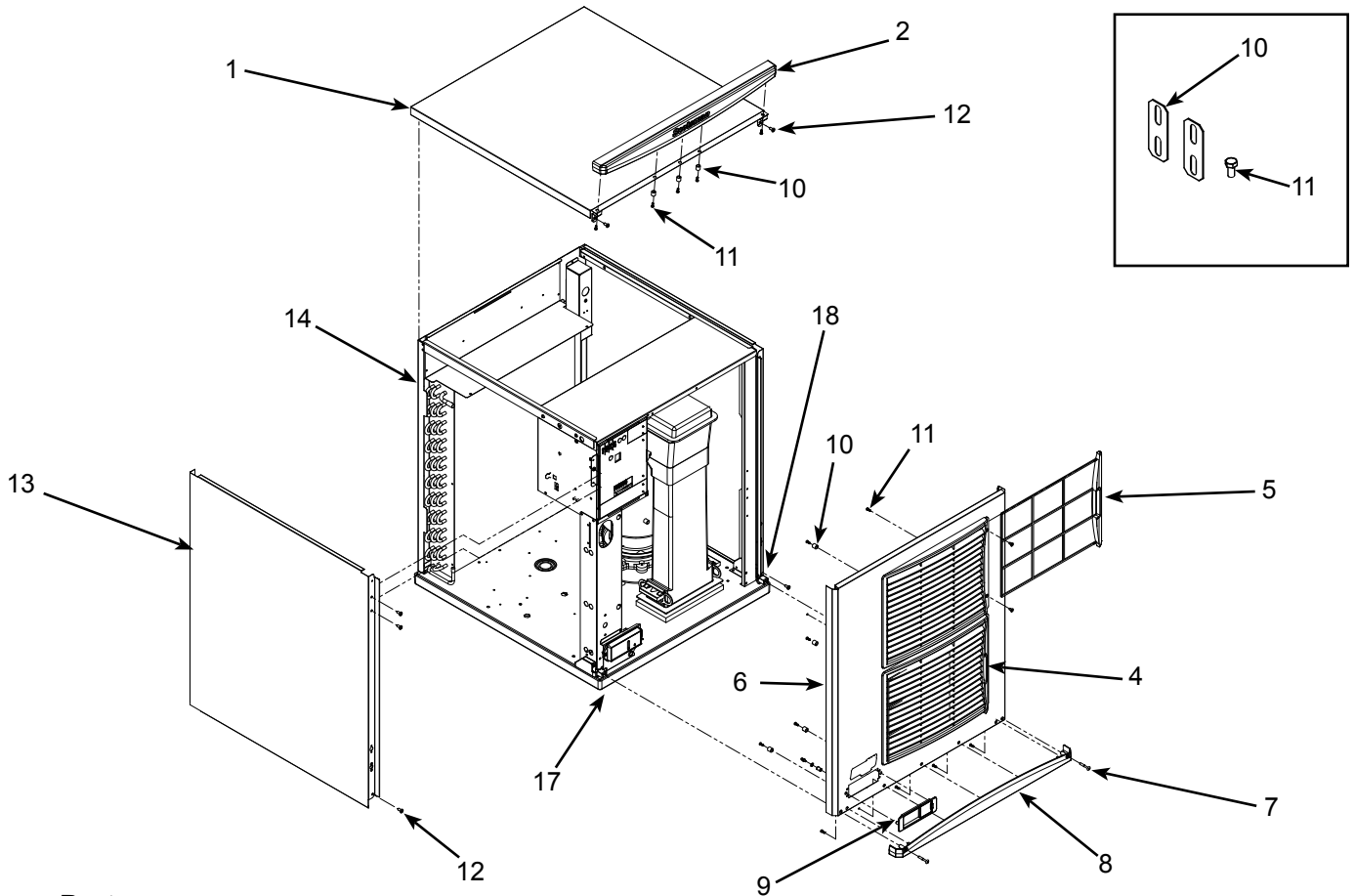

Item Number	Part Number	Description
1	A40309-022	Top panel, includes item 2
2	02-4819-02	Trim strip
3	A40335-022	Right side panel
4	02-4224-03	Louvers
5	02-4212-03	Air filter
6	A40308-028	Front panel, AC includes items 4, 5, 7, 8 and 9
6a	A40308-029	Front panel, WC or RC. Includes items 4, 5, 7, 8 & 9
7	03-1735-03	Screw
8	02-4820-02	Tim strip
9	02-4821-02	Bezel, includes standard door
9a	02-4822-01	Door, bezel with handle
9b	02-4822-02	Door, bezel secure
10	02-4824-01	Spacer
11	03-3836-02	Screw
12	03-1404-10	Screw
13	A40310-025	Left side panel, AC
	A40310-026	Left side panel, WC or RC
14	A39194-001	Back panel, WC or RC
15	A30911-015	Machine straps
16	03-1405-15	Screw
17	02-4823-21	*Panel mount kit, left
18	02-4823-22	*Panel mount kit, right

*Includes both screw receptacles

N0422, F0522, N0622, F0822, N0922, F1222, N1322, F1522

Service Parts

Interior Cabinet, Water, and Chute Systems - Clear Reservoir Cover

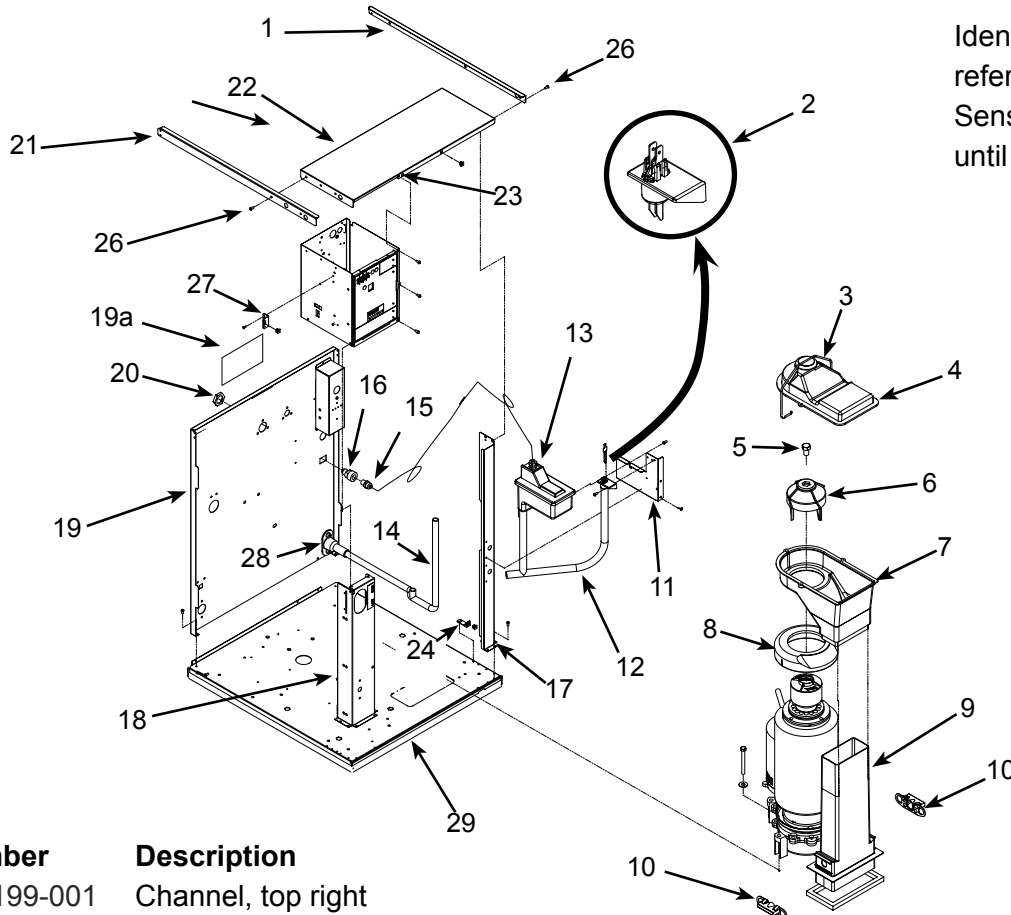

Identification reference: Water Sensor in Hose. Used until June 2012.

Item Number	Part Number	Description
1	A39199-001	Channel, top right
2	02-4449-21	Water sensor
3	A34969-001	Bail clamp
4	02-2930-04	Chute cover
5	03-1405-52	Cap screw
6	02-3001-01	Ice sweep
7	02-3841-01	Ice chute
8	13-0929-01	Insulation collar, flakers
	13-0929-02	Insulation collar, nuggets
9	02-2929-03	Ice chute lower*
	02-2929-04	Ice chute lower**
10	A37708-021	Bin control set (2)
11	A39200-001	Reservoir bracket
12	A39336-001	Evaporator inlet hose*
	02-4338-01	Evaporator inlet hose**
13	02-3371-01	Water reservoir & valve
13a	02-3371-02	Float and arm only
13b	02-3266-03	Plunger/seat only
14	A39310-001	Drain hose*
	02-4339-01	Drain hose**
15	16-1039-01	Connector, male
16	16-0835-01	Flare fitting, male
17	A39201-001	Post, right front *
	A39182-001	Post, right front **
18	A39196-001	Post, control box*
	A39184-001	Post, control box**
19	A39191-001	Back panel A-D series, WC, RC*
	A40652-001	Back panel E series, WC, RC*
	A39194-001	Back panel A-D series, WC, RC**
19a	A40654-001	Back filler panel E series*
20	03-1394-01	Pal nut
21	A39185-001	Channel, top left
22	A39181-001	Control box cover
23	03-3804-01	Receptacle
24	A38732-001	Panel mount
25	13-0895-01	Tubing, order 3
25a	16-0871-01	Brass insert, at float valve
26	03-1531-01	Screw
27	A39025-001	Bracket
28	02-3692-21	Drain fitting
29	02-4524-21	Base, fits Tecumseh or Copeland RST - note RST used in B series
	02-4524-22	Base, fits Copeland CS

* for N0422, F0522, N0622, F0822

** for N0922, F1222, N1322, F1522

N0422, F0522, N0622, F0822, N0922, F1222, N1322, F1522

Service Parts

Interior Cabinet, Water, and Chute Systems - White Reservoir Cover & D or E Series

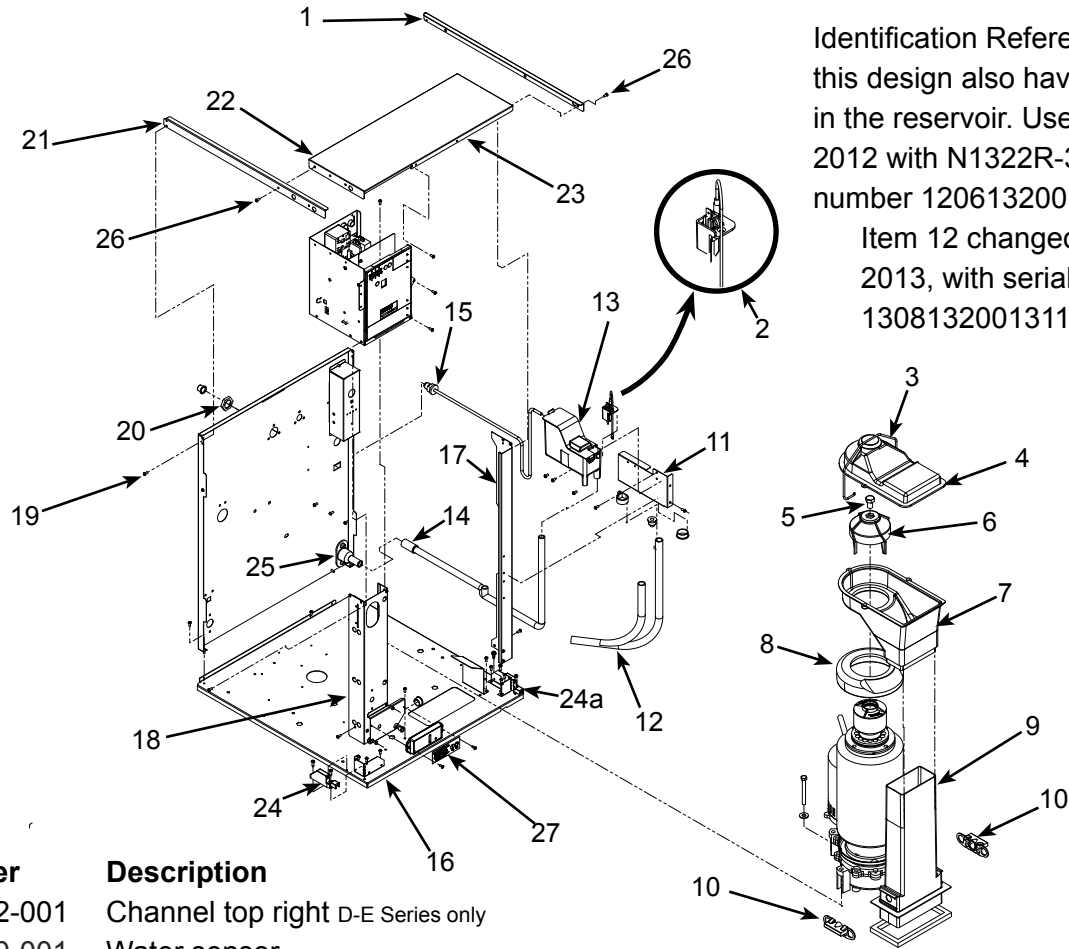

Identification Reference: Units with this design also have water sensor in the reservoir. Use began June 18, 2012 with N1322R-32A serial number 12061320013354.

Item 12 changed August 2013, with serial number 13081320013114

Item Number	Part Number	Description
1	A40362-001	Channel top right D-E Series only
2	A39790-001	Water sensor
3	A34969-001	Bail clamp
4	02-2930-04	Chute cover
5	03-1405-52	Cap screw
6	02-3001-01	Ice sweep
7	02-3841-01	Ice chute
8	13-0929-01	Insulation collar, flakers
	13-0929-02	Insulation collar, nuggets
9	02-2929-03	Ice chute lower*
	02-2929-04	Ice chute lower**
10	A37708-021	Bin control set (2)
11	A40029-001	Reservoir bracket
12	A40189-001	Evaporator inlet hose*
	02-4752-01	Evaporator inlet hose**
13	A39789-001	Water reservoir & valve
13a	02-2217-02	Float and arm only
14	A40031-001	Drain hose*
	02-4708-01	Drain hose**
15	16-1198-01	Fitting only
16	02-4524-21	Base, fits Tecumseh or Copeland RST - note RST used in B & D series
16	02-4524-22	Base, fits Copeland CS
17	A39201-001	Post, right front *
	A39182-001	Post, right front **
18	A39196-001	Post, control box*
	A39184-001	Post, control box**
19	A39191-001	Back panel A-D series, WC, RC*
	A40652-001	Back panel E series, WC, RC*
	A39194-001	Back panel A-D series, WC, RC**
19a	A40654-001	Back filler panel E series*
	03-1394-01	Pal nut
21	A40361-001	Channel, top left D Series only
22	A39181-001	Control box cover
23	03-3804-01	Receptacle, use discontinued
24	02-4823-21	*Panel mount kit, left
24a	02-4823-22	*Panel mount kit, right
		*Includes both screw receptacles
25	02-3692-21	Drain fitting
26	03-1531-01	Screw
27	11-0622-21	Lower light & sw panel

N0422, F0522, N0622, F0822, N0922, F1222, N1322, F1522

Service Parts

Refrigeration Condensing, Air Cooled

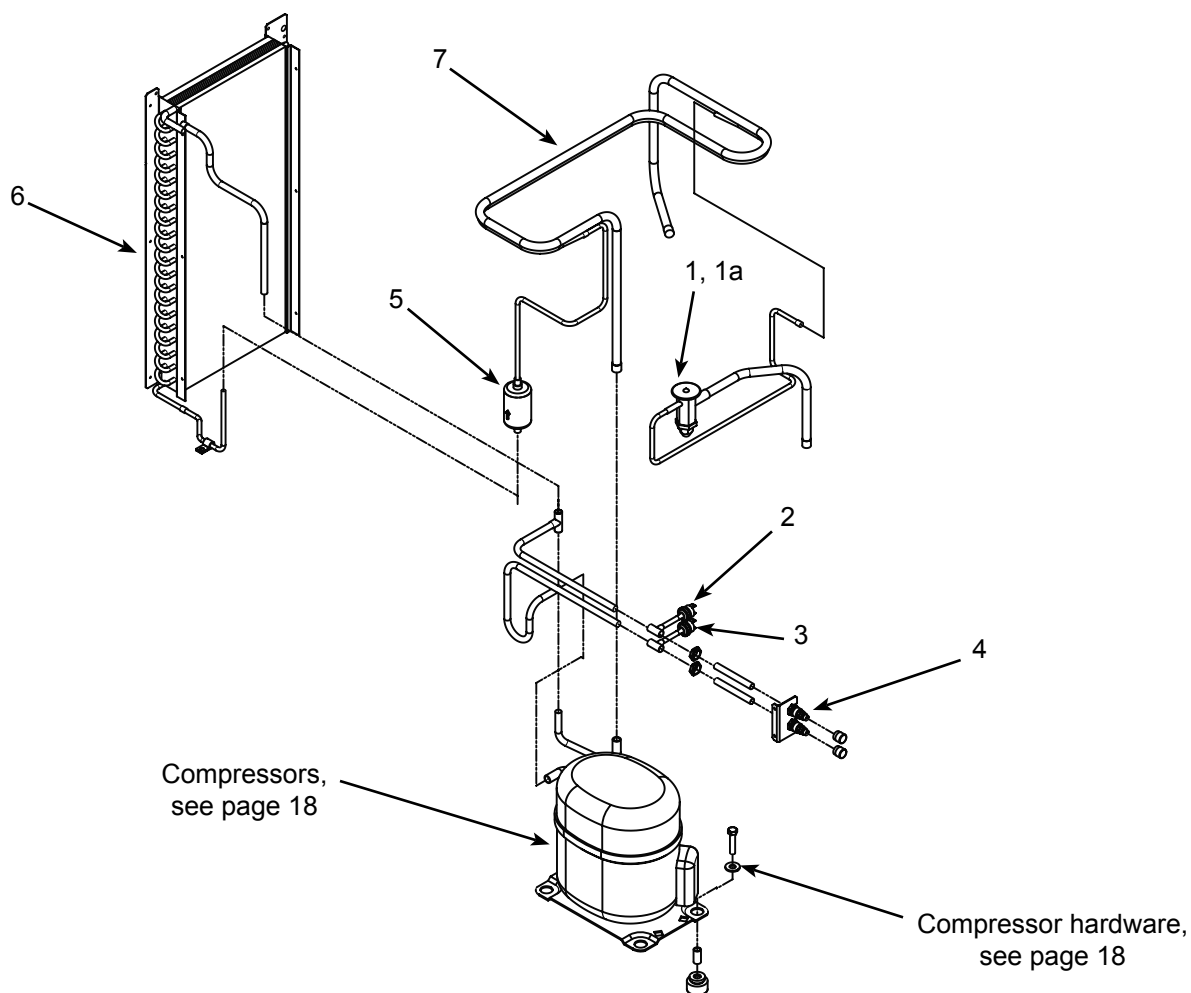

Item Number	Part Number	Description
1	16-1144-21	TXV, N0422, F0522
	16-1144-22	TXV, N0622, F0822
	16-1144-24	TXV, N0922, F1222
	16-1144-23	TXV, N1322, F1522
1a	02-4406-01	Insulation, TXV
2	11-0501-22	High pressure cut out sw
3	11-0502-21	Low pressure cut out sw
4	16-1137-01	Access valve seat
4a	16-1139-01	Access valve core
4b	16-1140-01	Access valve cap
5	02-3319-01	Filter dryer
6	18-8890-01	Air cooled condenser, fits N0422, F0522, N0622, F0822
	18-8935-01	Air cooled condenser, fits N0922, F1222,
	18-8936-01	Air cooled condenser, fits N1322, F1522
7	A39249-001	Suction line for Tecumseh
	A39249-002	Suction line for Copeland

N0422, F0522, N0622, F0822, N0922, F1222, N1322, F1522

Service Parts

Condenser Fan Motor System - N0422, F0522, N0622, F0822

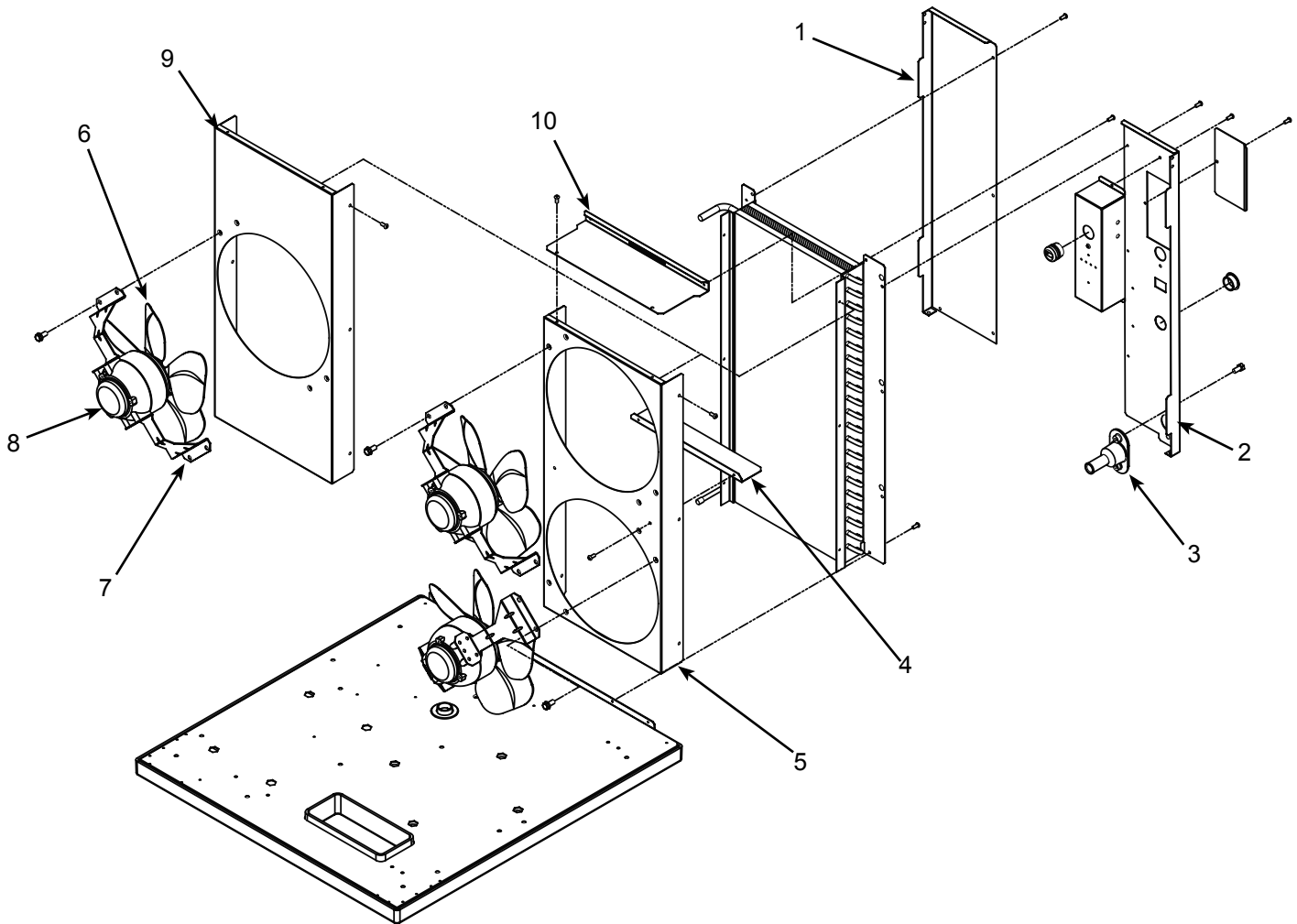

Item Number	Part Number	Description
1	A39186-001	Condenser flange A-D series
	A40651-001	Condenser flange E series
2	A39187-001	Condenser flange
3	02-3692-21	Drain fitting
4	A38675-001	Shroud divider
5	A39351-001	Shroud, N0622, F0822
6	18-8836-01	Fan blade
7	A38480-001	Bracket, fan motor
8	12-1681-23	Fan motor, 115 volt
	12-1681-04	Fan motor, 208-230 volt/50 or 60 Hz
9	A39350-001	Shroud, N0422, F0522
10	A39352-001	Shroud top

N0422, F0522, N0622, F0822, N0922, F1222, N1322, F1522

Service Parts

Condenser Fan Motor System, N0922, F1222, N1322, F1522

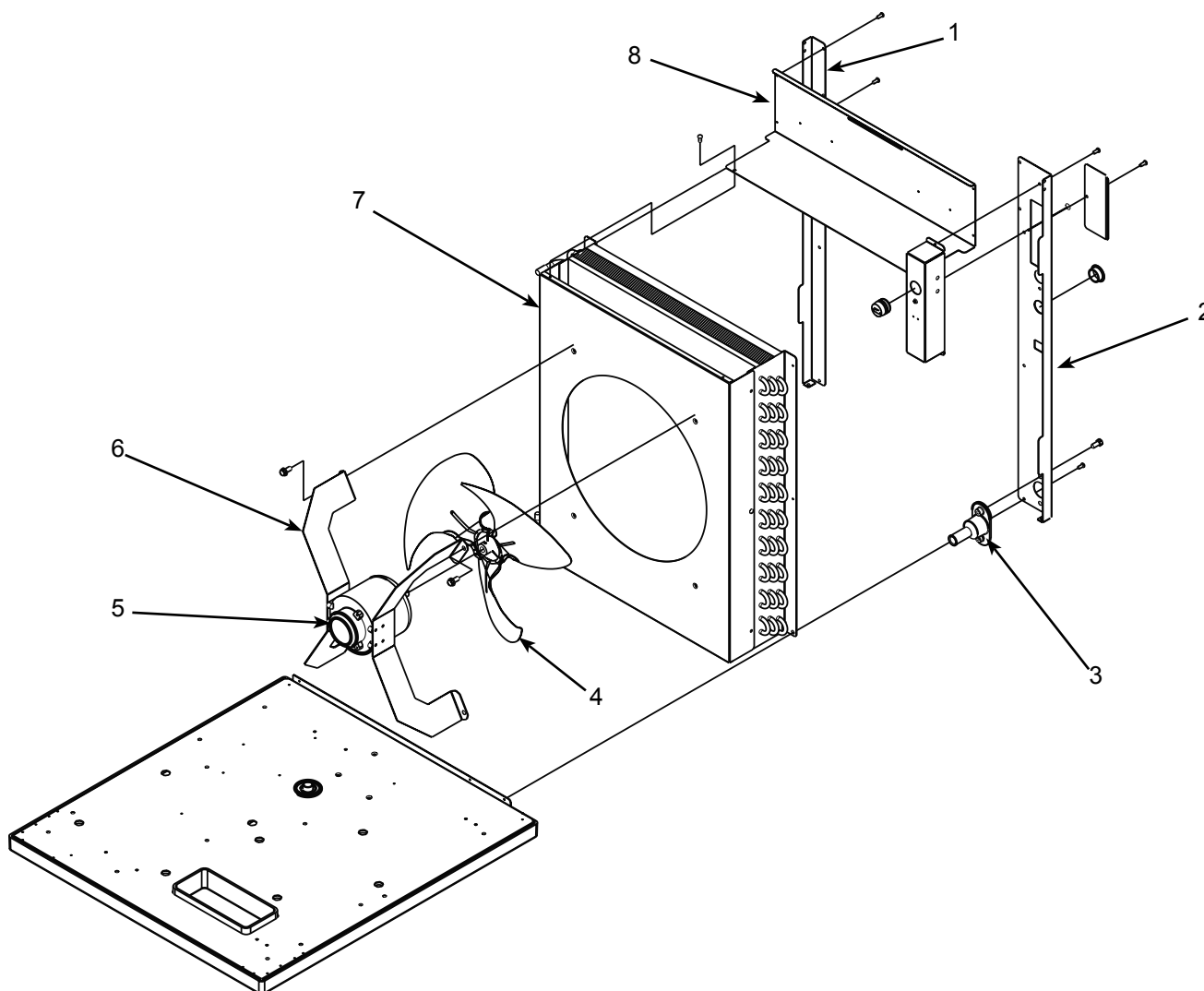

Item Number	Part Number	Description
1	A39188-001	Condenser flange
2	A39189-001	Condenser flange
3	02-3692-21	Drain fitting
4	18-8882-01	Fan blade
5	18-8927-01	Fan motor
6	A40156-001	Bracket, fan motor
7	A39193-001	Shroud
8	A39353-001	Shroud top

N0422, F0522, N0622, F0822, N0922, F1222, N1322, F1522

Service Parts

Refrigeration Condensing, Water Cooled

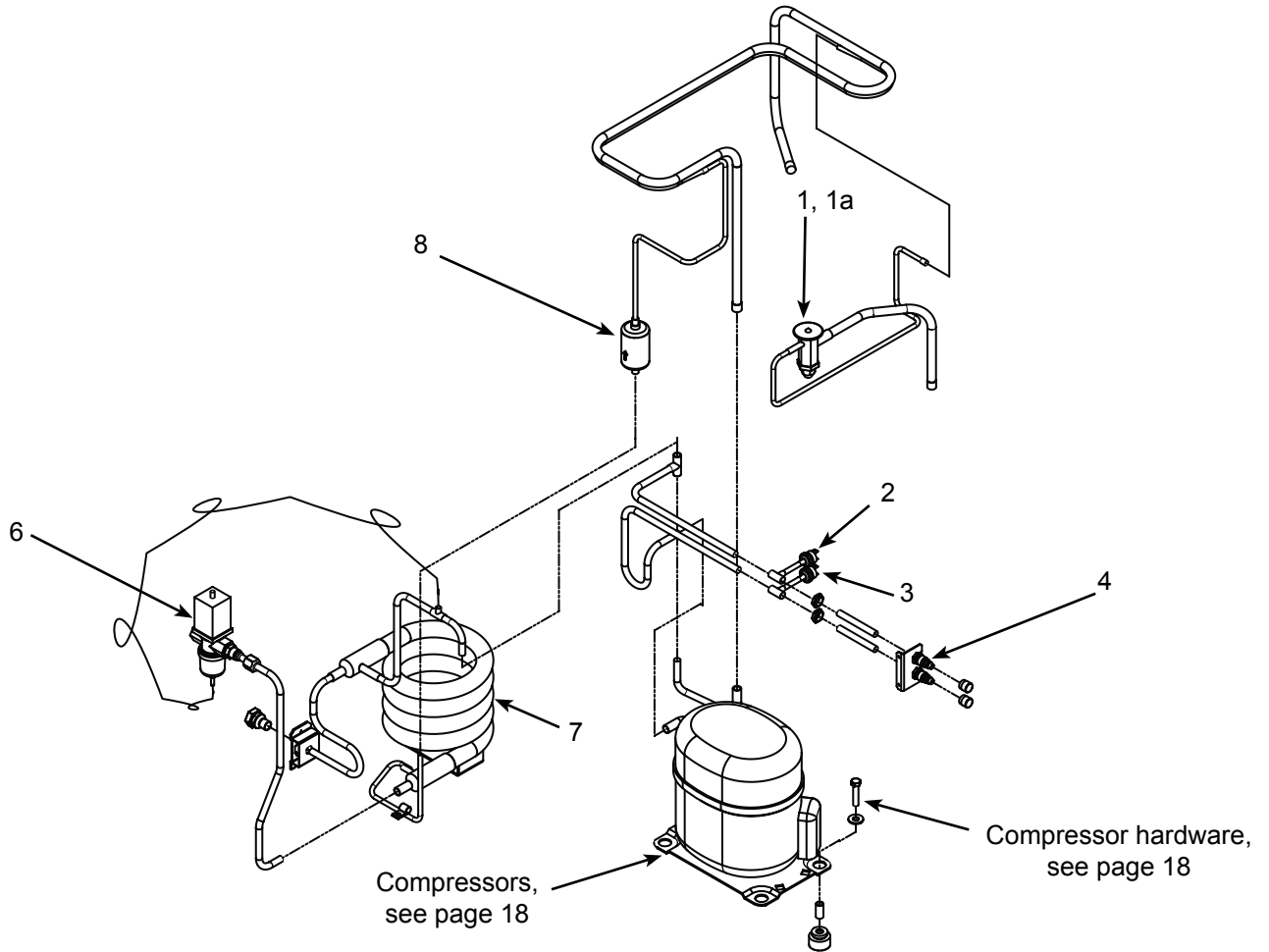

Item Number	Part Number	Description
1	16-1144-21	TXV, N0422, F0522
	16-1144-22	TXV, N0622, F0822
	16-1144-24	TXV, N0922, F1222
	16-1144-23	TXV, N1322, F1522
1a	02-4406-01	Insulation, TXV
2	11-0501-22	High pressure cut out sw
3	11-0502-21	Low pressure cut out sw
4	16-1137-01	Access valve seat
4a	16-1139-01	Access valve core
4b	16-1140-01	Access valve cap
5	16-1154-22	Condenser drain fitting
6	11-0608-21	Water regulating valve A-D Series
6a	11-0608-24	Water regulating valve E Series
7	18-8871-21	Condenser, water cooled fits N0422, F0522, N0622, F0822, N0922, F1222
	18-8893-21	Condenser, water cooled fits N1322 and F1522
	16-0874-01	Receiver, not shown, fits F1222W or N0922W

N0422, F0522, N0622, F0822, N0922, F1222, N1322, F1522

Service Parts

Refrigeration Condensing, Remote Cooled

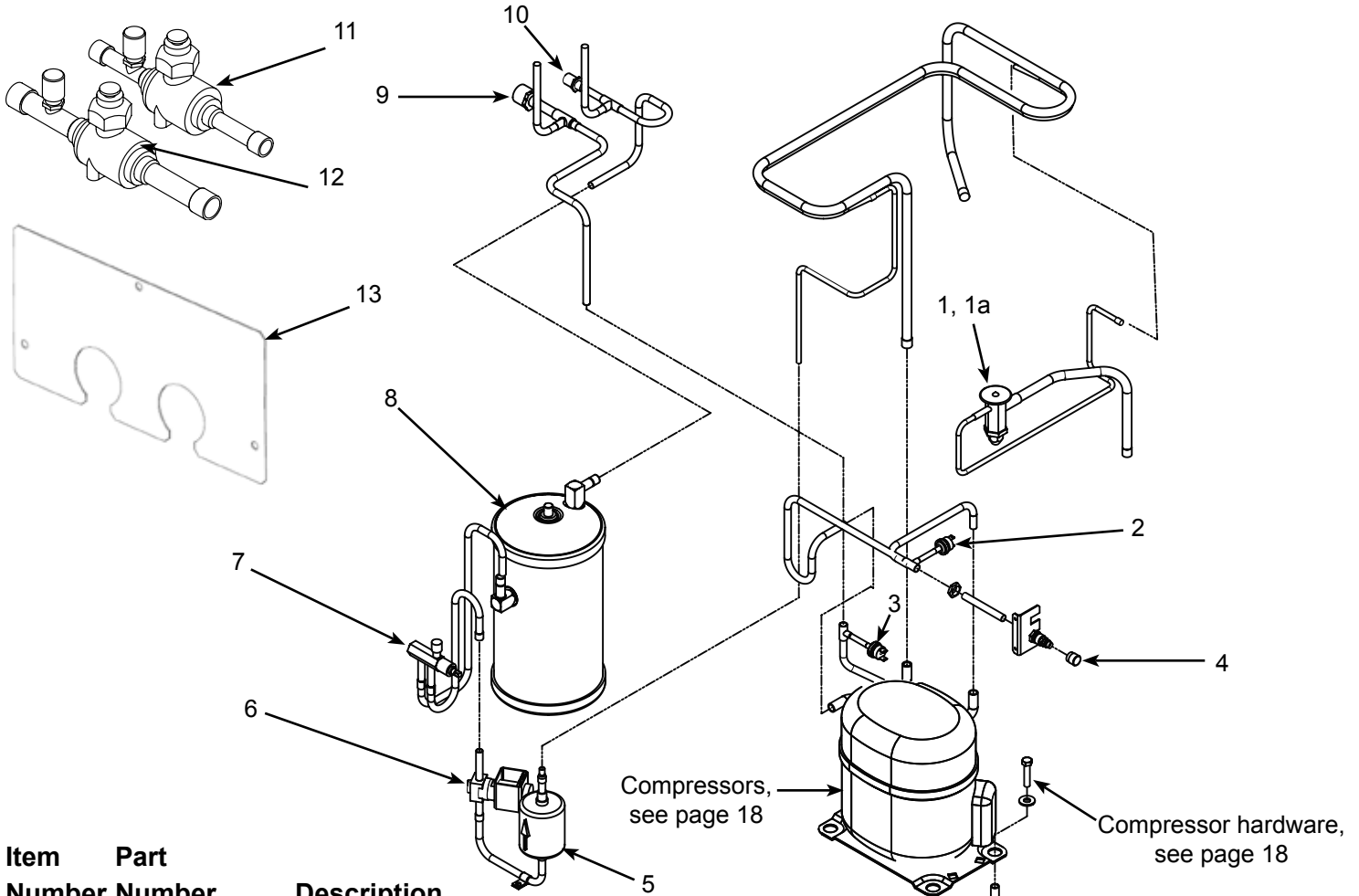

Item Number	Part Number	Description
1	16-1144-22	TXV, N0622, F0822
	16-1144-24	TXV, N0922, F1222
	16-1144-23	TXV, N1322, F1522
1a	02-4406-01	Insulation, TXV
2	11-0502-21	Low pressure cut out sw
3	11-0501-22	High pressure cut out sw
4	16-1137-01	Access valve seat
4a	16-1139-01	Access valve core
4b	16-1140-01	Access valve cap
5	02-3319-02	Filter dryer
6	11-0493-01	Liquid line solenoid valve, 208-
		230 volt, 50/60 Hz
	12-2719-22	230 volt coil
	11-0493-02	Liquid line solenoid valve, 115
		volt
	12-2719-21	115 volt coil
	12-2733-30	LLV/HGV rebuild kit
7	16-1030-01	Receiver outlet valve
8	16-1176-01	Receiver

Item Number	Part Number	Description
8a	A37211-001	Bracket, receiver top
8b	A37212-001	Bracket, receiver bottom
9	16-0850-01	Discharge quick connect A-D Series
10	16-0850-03	Liquid quick connect A-D Series
11	16-1208-01	Isolation valve 3/8
12	16-1208-02	Isolation valve 1/2
13	A40508-001	Isolation valves cover order 2
14	A40507-001	Isolation valves bracket

E Series

N0422, F0522, N0622, F0822, N0922, F1222, N1322, F1522

Service Parts

Remote Condenser - ERC111 or ERC311

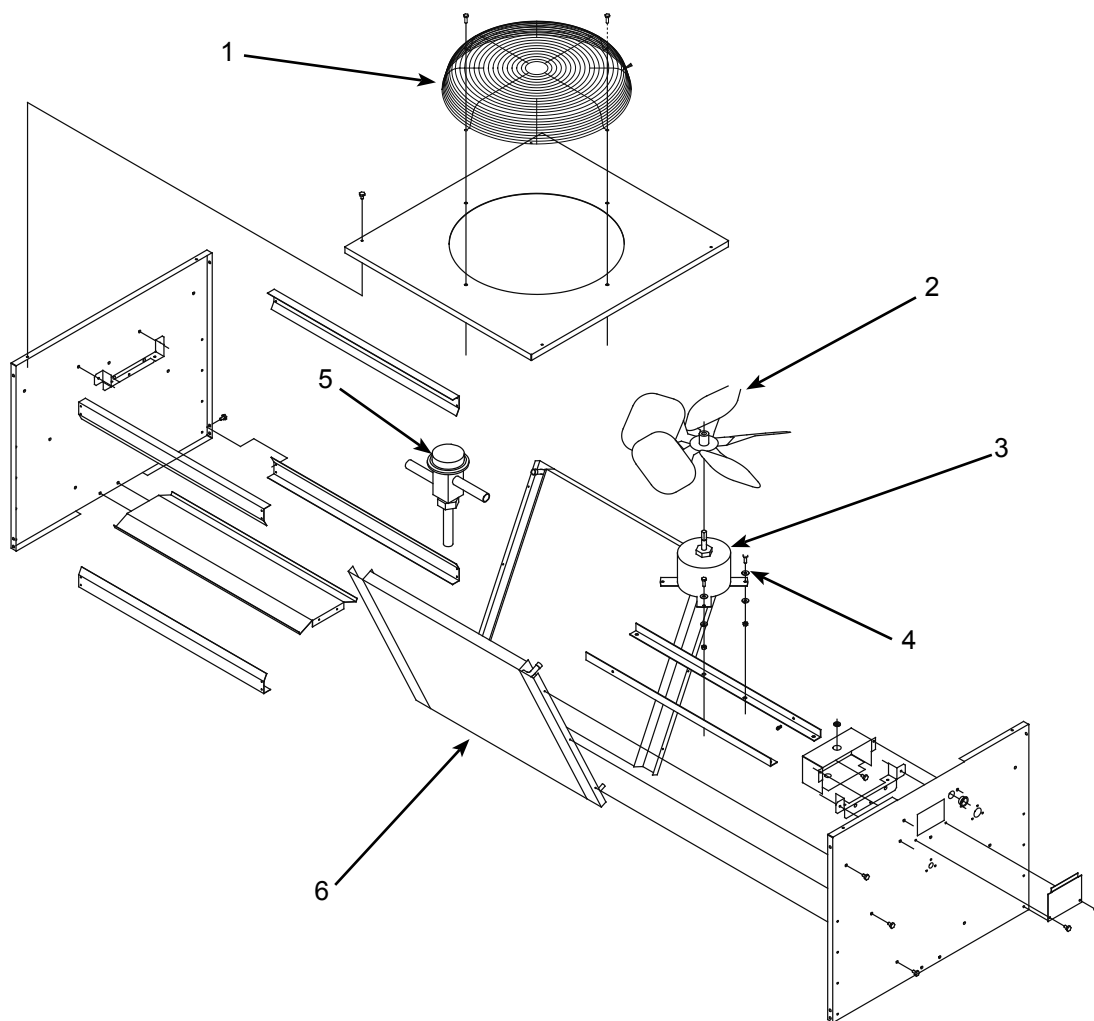

Item Number	Part Number	Description
1	02-3575-01	Fan guard
2	18-8816-01	Fan blade
3	12-2651-01	Fan motor - ERC311 (208-230 volt)
	12-2651-02	Fan motor - ERC111 (115 volt)
4	03-1405-08	Screw
5	11-0422-22	Headmaster
6	18-8827-01	Coil

Not shown:

NS1 A37169-001 Leg

NS2 A37170-001 Leg brace

NS3 03-1645-01 Screw for legs

NS4 16-0850-01 Quick disconnect, discharge A-D Series

NS5 16-0850-03 Quick disconnect, liquid A-D Series

NS6 16-1057-01 Line set tube end, discharge A-D Series

NS7 16-1057-02 Line set tube end, liquid A-D Series

N0422, F0522, N0622, F0822, N0922, F1222, N1322, F1522

Service Parts

Nugget Evaporator System, N0422, N0622, N0922, N1322

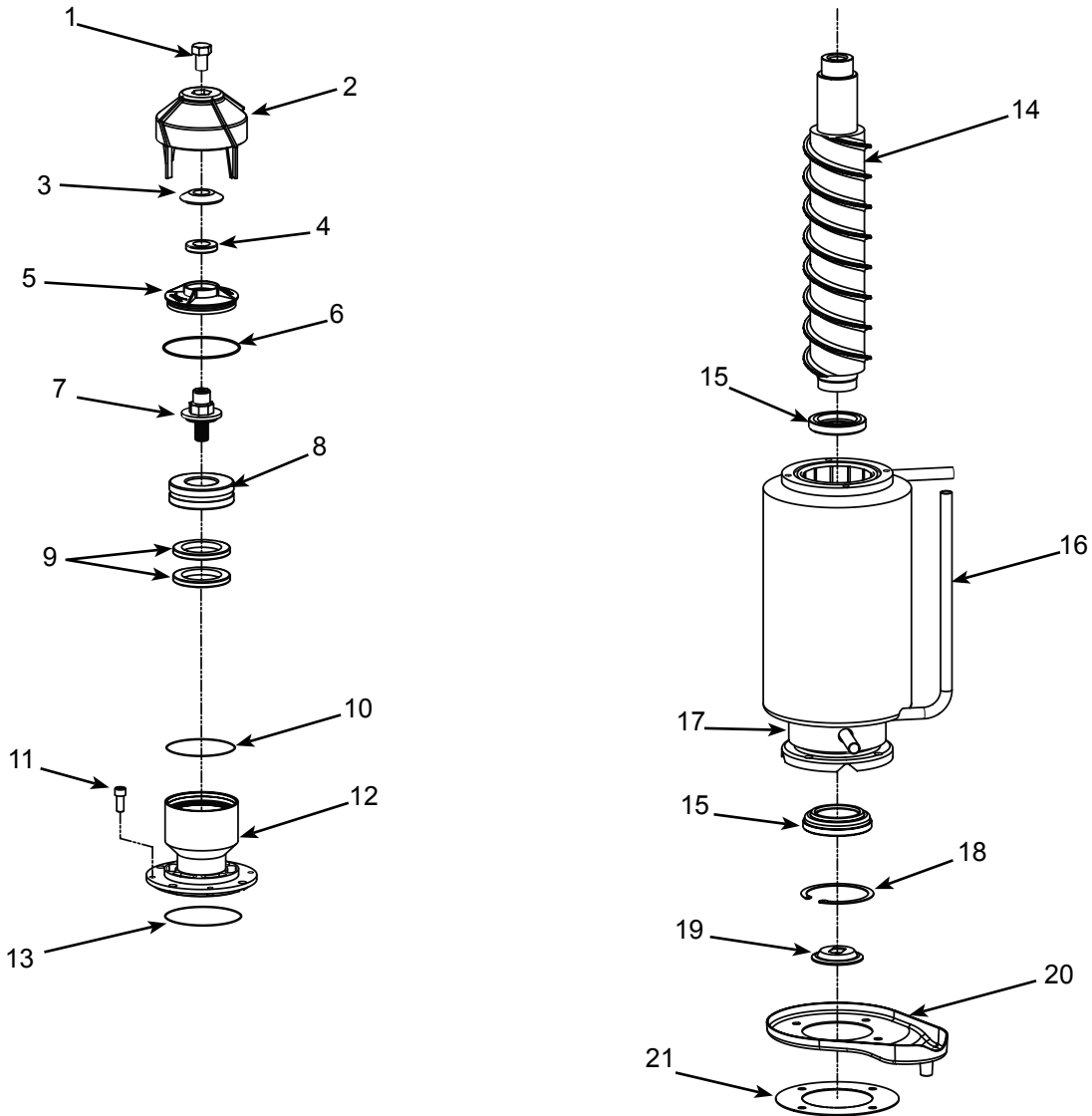

Item Number	Part Number	Description
1	03-1405-52	Cap screw
2	02-3001-01	Ice sweep
3	13-0871-01	Water shed
4	02-2978-01	Lip seal
5	02-3128-20	Cover, includes item 4
6	13-0617-54	O-ring
7	08-0660-01	Auger stud
8	A34559-020	Bearing
9	02-2977-01	Lip seal
10	13-0617-52	O-ring - to chute
11	03-1544-08	Screw, socket head
12	A32900-020	Nugget breaker assembly, includes items 3,4,5,6,8,9 and 13
13	13-0617-45	O-ring
14	A38071-021	Auger, N0422, N0622
	A38071-022	Auger, N0922, N1322
15	02-0929-23	Water seal
16	02-4350-21	Evaporator, N0422, N0622
	02-4352-21	Evaporator, N0922, N1322
16a	03-1405-41	Cap screw to gear box
17	02-4358-01	Collar
18	A32777-001	Retaining ring
19	02-4663-01	Water shed
20	02-3837-01	Drip pan
21	13-0704-00	Gasket

N0422, F0522, N0622, F0822, N0922, F1222, N1322, F1522 Service Parts

Evaporator System, Flakers F0522, F0822, F1222, F1522

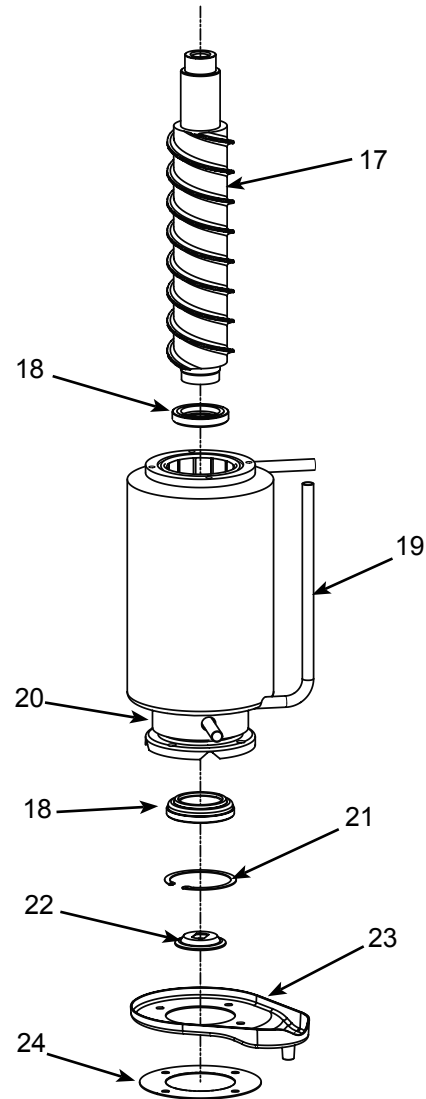
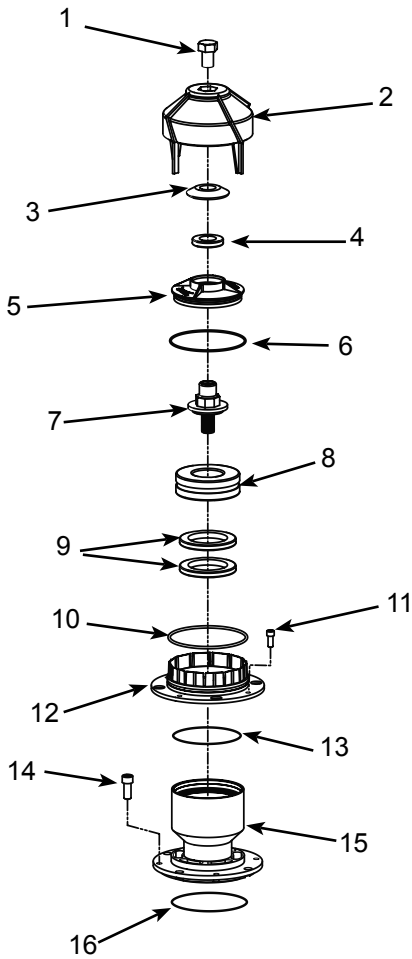

Item Number	Part Number	Description
1	03-1405-52	Cap screw
2	02-3001-01	Ice sweep
3	13-0871-01	Water shed
4	02-2978-01	Lip seal
5	02-3128-20	Cover, includes item 4
6	13-0617-54	O-ring
7	08-0660-01	Auger stud
8	A34559-020	Bearing
9	02-2977-01	Lip seal
10	13-0617-52	O-ring, to chute
11	03-1403-27	Screw
12	02-2916-01	Slotted collar
13	13-0617-49	O-ring, under slotted collar
14	03-1544-08	Screw, socket head
15	A34505-020	Flaker breaker assembly, includes items 3,4,5,6,8,9, and 16
16	13-0617-45	O-ring
17	A38071-021	Auger, F0522, F0822
	A38071-022	Auger, F1222, F1522
18	02-0929-23	Water seal
19	02-4350-21	Evaporator, F0522, F0822
	02-4352-21	Evaporator, F1222, F1522
19a	03-1405-41	Cap screw to gear box
20	02-4358-01	Collar
21	A32777-001	Retaining ring
22	02-4663-01	Water shed
23	02-3837-01	Drip pan
24	13-0704-00	Gasket

N0422, F0522, N0622, F0822, N0922, F1222, N1322, F1522

Service Parts Gear Reducer and Motor

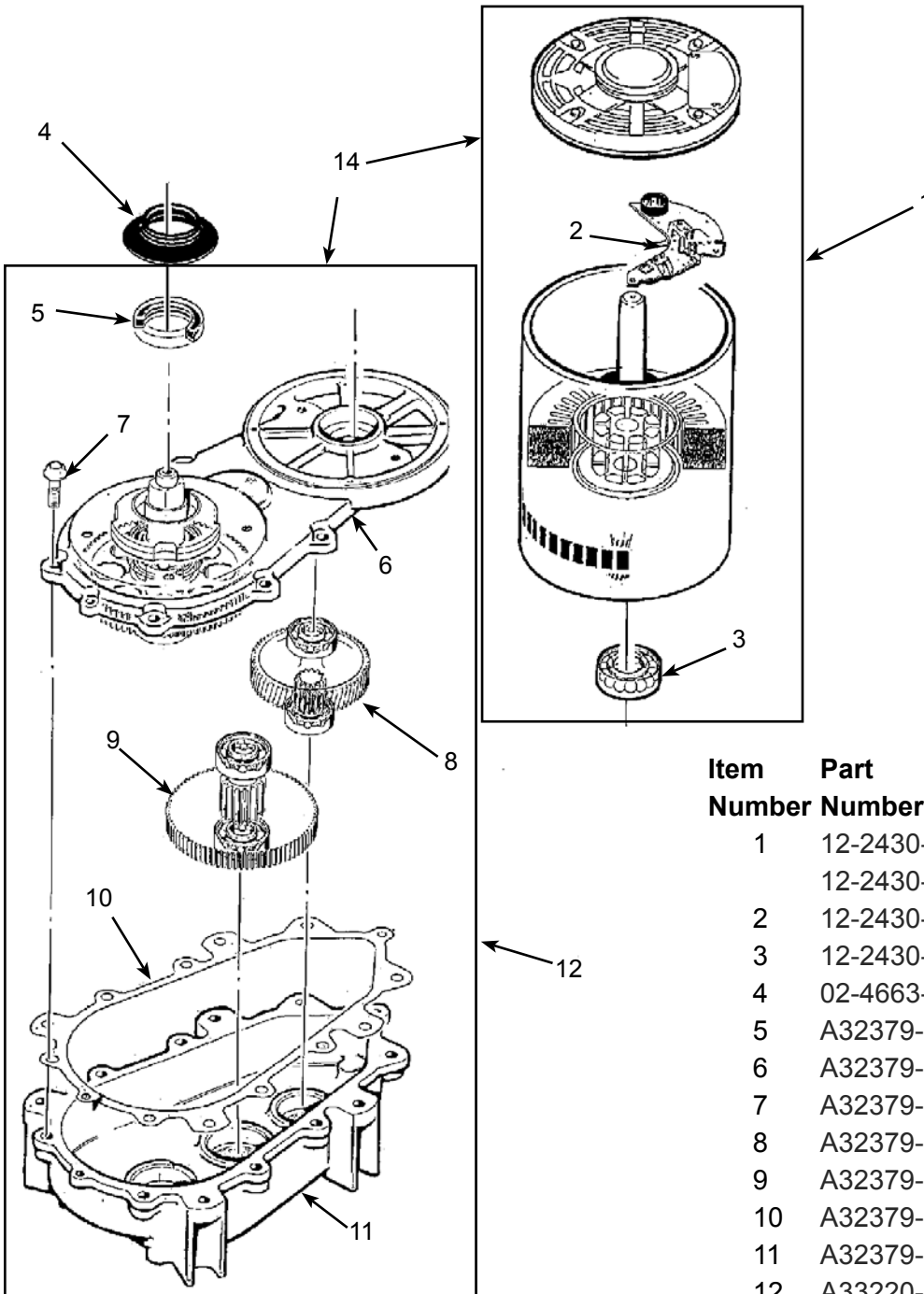

Item Number	Part Number	Description
1	12-2430-21+	Drive motor, 115 volt
	12-2430-22+	Drive Motor, 208-230 volt
2	12-2430-44	Start switch
3	12-2430-29	Bearing
4	02-4663-01	Water Shed
5	A32379-029*	Seal
6	A32379-022	Gearcase Cover*
7	A32379-026	Bolt
8	A32379-024	First Gear & Bearings
9	A32379-023	2nd Gear & Bearings
10	A32379-021	Gasket
11	A32379-020	Gear Case
12	A33220-030	Gearcase kit, assembled w/out motor, includes item 13
13	A32379-027	Oil, 1 Container
14	A33220-021**	Complete 115 volt
	A33220-022**	Complete 208-230 volt

* Cover includes output shaft, seal, gear and bearings.

If water has flowed thru the seal, the gearcase cover assembly should be replaced, not just the seal.

** Includes items 1, 12, and is charged with gear oil.

Oil Charge is 14 Oz.



N0422, F0522, N0622, F0822, N0922, F1222, N1322, F1522

Service Parts Electrical & Control Box

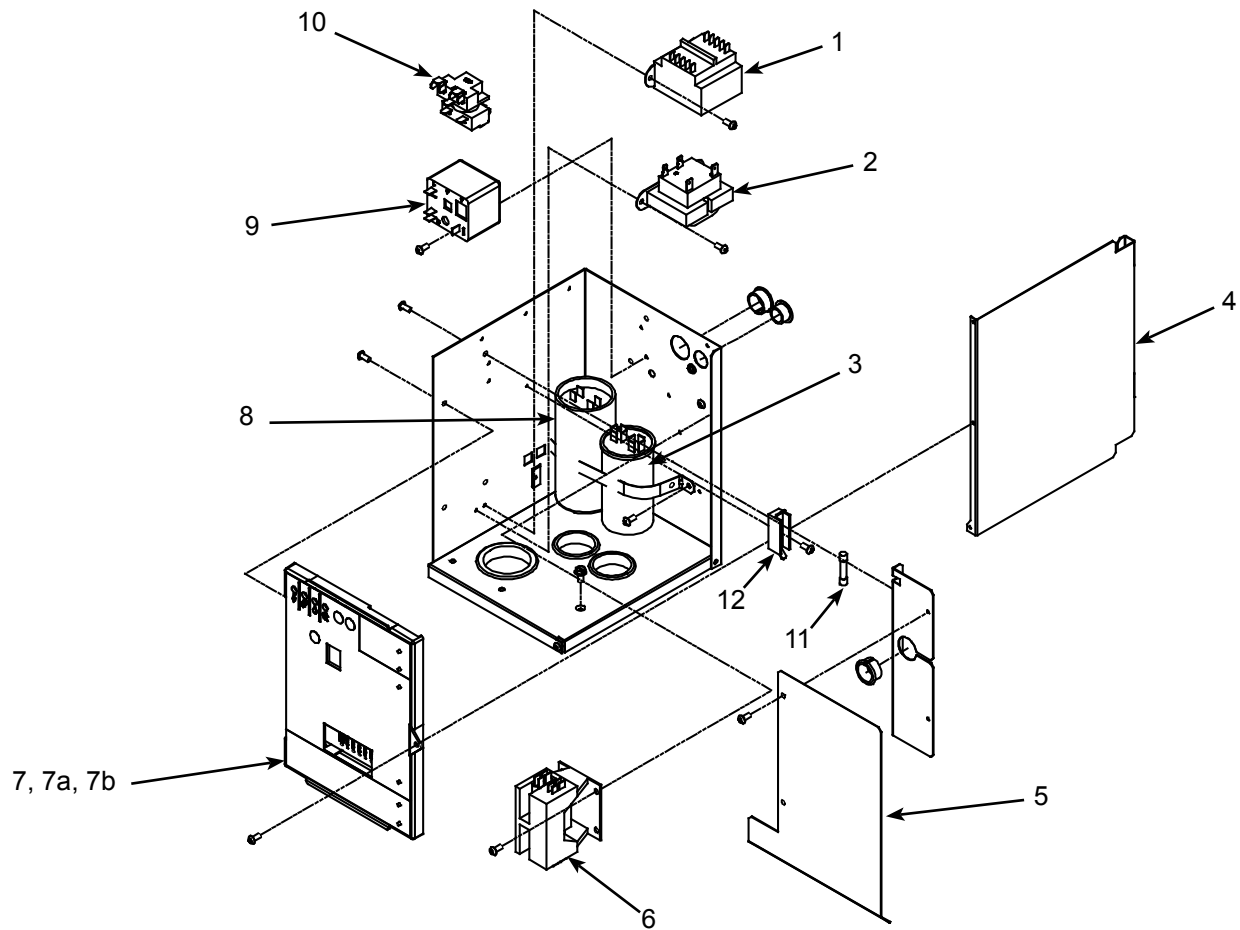

Item Number	Part Number	Description	Harnesses (not shown)
1	12-2639-01	Transformer, 50 Hz	NS1 12-2976-01 Low voltage harness
2	12-2924-01	Transformer, 115 v	NS2 12-2994-01 High voltage harness, AW
	12-2924-02	Transformer, 208-230 60 Hz	NS3 12-2966-01 High voltage harness, Rem
3	see page 15	Run capacitor	
4	A39198-001	Side cover	
5	A39216-001	Shield	
6	12-2469-03	Contactors, 115 volt	
	12-2469-02	Contactors, 208-230 volt 60 Hz, single phase	
	12-2533-02	Contactors, 3 phase	
7	11-0575-22	Controller for A or B series.	
	11-0623-21	Controller for Prodigy Plus D series and all prior	
7a	02-4407-01	Graphic overlay	
7b	02-4076-01	Control box door	
8	see next page	Start capacitor	
9	see next page	Potential relay	
10	see next page	Start relay	
11	12-2686-01	Fuse, 50 Hz only	
12	12-2687-01	Fuse block, 50 Hz only	

N0422, F0522, N0622, F0822, N0922, F1222, N1322, F1522

Service Parts

Compressors

Model	Series	Electrical	Compressor	Overload	Relay	Start Cap	Run Cap
N0422, F0522 -1	A or D	115/60/1	18-8929-21	18-8929-23	18-1903-64	18-1901-63	not used
N0622, F0822 -1	A	115/60/1	18-8921-21	18-8921-23	18-1903-68	18-1901-55	18-1902-45
N0622, F0822 -32	A	208-230/60/1	18-8921-22	18-8774-28	18-1903-67	18-1901-56	18-1902-68
N0622, F0822 -6	A	230/50/1	18-8921-26	18-8774-27	18-1903-66	18-1901-56	18-1902-68
N0622, F0822 -1	B* or D	115/60/1	18-8949-21	18-8949-50	18-1903-44	18-1901-65	18-1902-64
N0622, F0822 -32	B* or D	208-230/60/1	18-8949-22	18-8949-51	18-1903-54	18-1901-66	18-1902-30
N0622, F0822 -6	B* or D	230/50/1	18-8949-23	18-8949-52	18-1903-70	18-1901-52	18-1902-65
N0922, F1222 -32	A	208-230/60/1	18-8922-22	18-8922-27	18-1903-44	18-1901-66	18-1902-45
N0922, F1222 -3	A	208-230/60/3	18-8813-25	Internal	-	-	-
N0922, F1222 -6	A	230/50/1	18-8922-26	Internal	18-1903-69	18-1901-66	18-1902-71
N0922, F1222 -32	B** or D	208-230/60/1	18-8955-22	Internal	18-1903-54	18-1901-20	18-1902-67
N0922, F1222 -3	B** or D	208-230/60/3	18-8955-23	18-8955-53	-	-	-
N0922, F1222 -6	B** or D	230/50/1	18-8955-26	Internal	18-1903-71	18-1901-66	18-1902-63
N1322, F1522 -32	A or D	208-230/60/1	18-8749-22	Internal	18-1903-46	18-1901-48	18-1902-70
N1322, F1522 -6	A or D	230/50/1	18-8749-27	Internal	18-1903-33	18-1901-48	18-1902-70

* B series production began July 2011 ** B series production began April 2014

Compressor Mounting Hardware

Model	Bolt	Grommet	Washer	Sleeve
N0422, F0522, N0622, F0822	03-1405-20	18-4700-28	03-1407-07	18-0108-41
N0622, F0822 B	03-1405-20	18-2200-28	03-1407-07	18-2200-27
N0922, F1222 -32	03-1405-20	18-4700-28	03-1407-07	18-0108-41
N0922, F1222 -3	03-1405-20	18-2300-27	03-1407-07	18-2300-26
N1322, F1522 -32	03-1405-20	18-2300-27	03-1407-07	18-2300-26

Crankcase Heaters

Model	Series	Voltage	Heater
N0622R-1, F0822R-1	A	115	12-2942-01
N0622R-32, F0822R-32	A	230	12-2942-02
N0622R-1, F0822R-1	B or D	115	12-3043-01
N0622R-32, F0822R-32, N0922R, F1222R -3 or -32	B or D	230	12-3043-02
N0922R-32, F1222R-32	A	230	12-2942-02
N0922R-3, F1222R-3	A	230, 3 phase	12-3043-03
N1322R -32, -3, F1522R-32, -3	A or D	230	12-3043-03

N0422, F0522, N0622, F0822, N0922, F1222, N1322, F1522

Service Parts

Wiring Diagram N0422 and F0522 A Series

17-3211-01

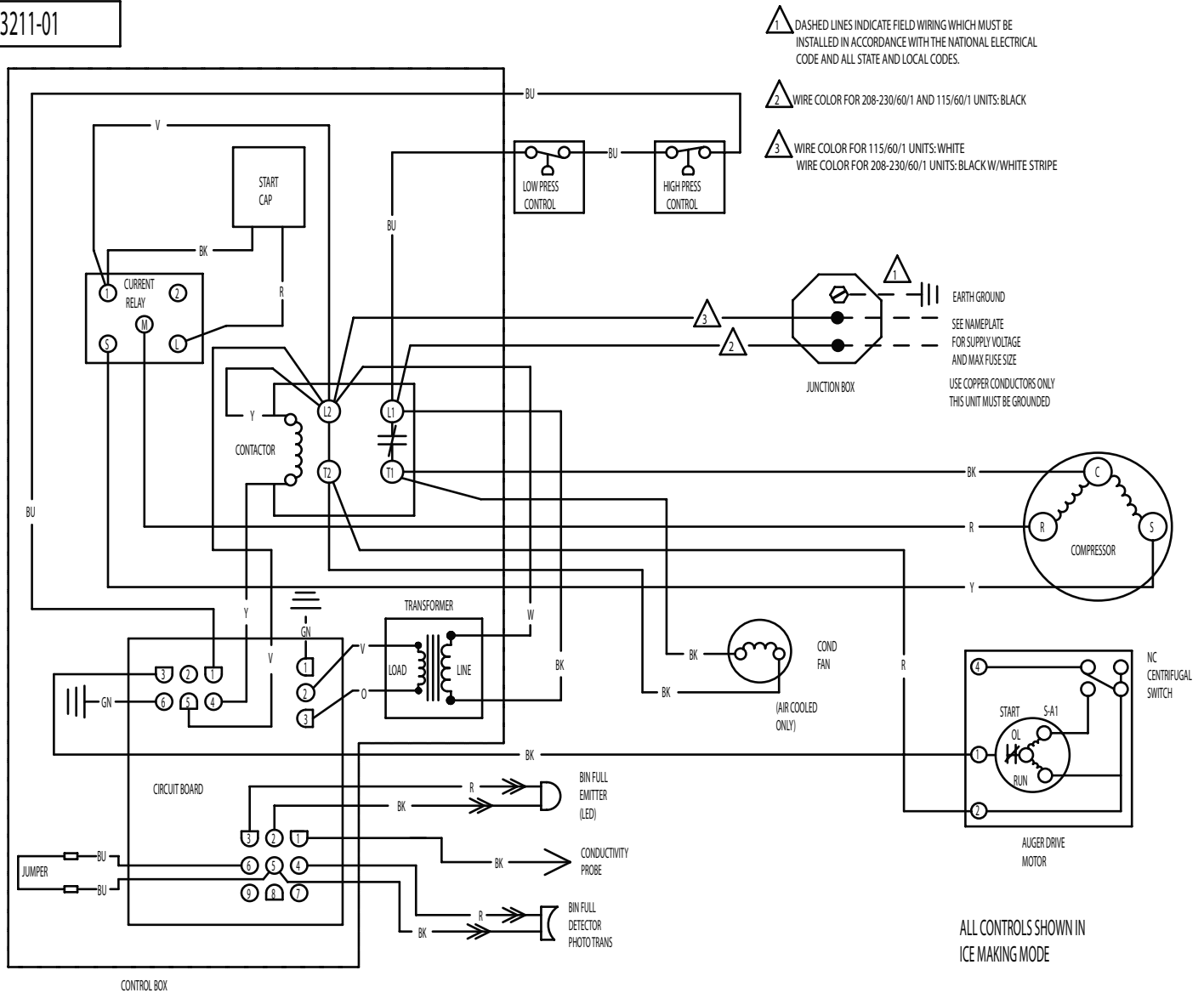

N0422, F0522, N0622, F0822, N0922, F1222, N1322, F1522

Service Parts

Schematic Diagram N0422 or F0522 A Series

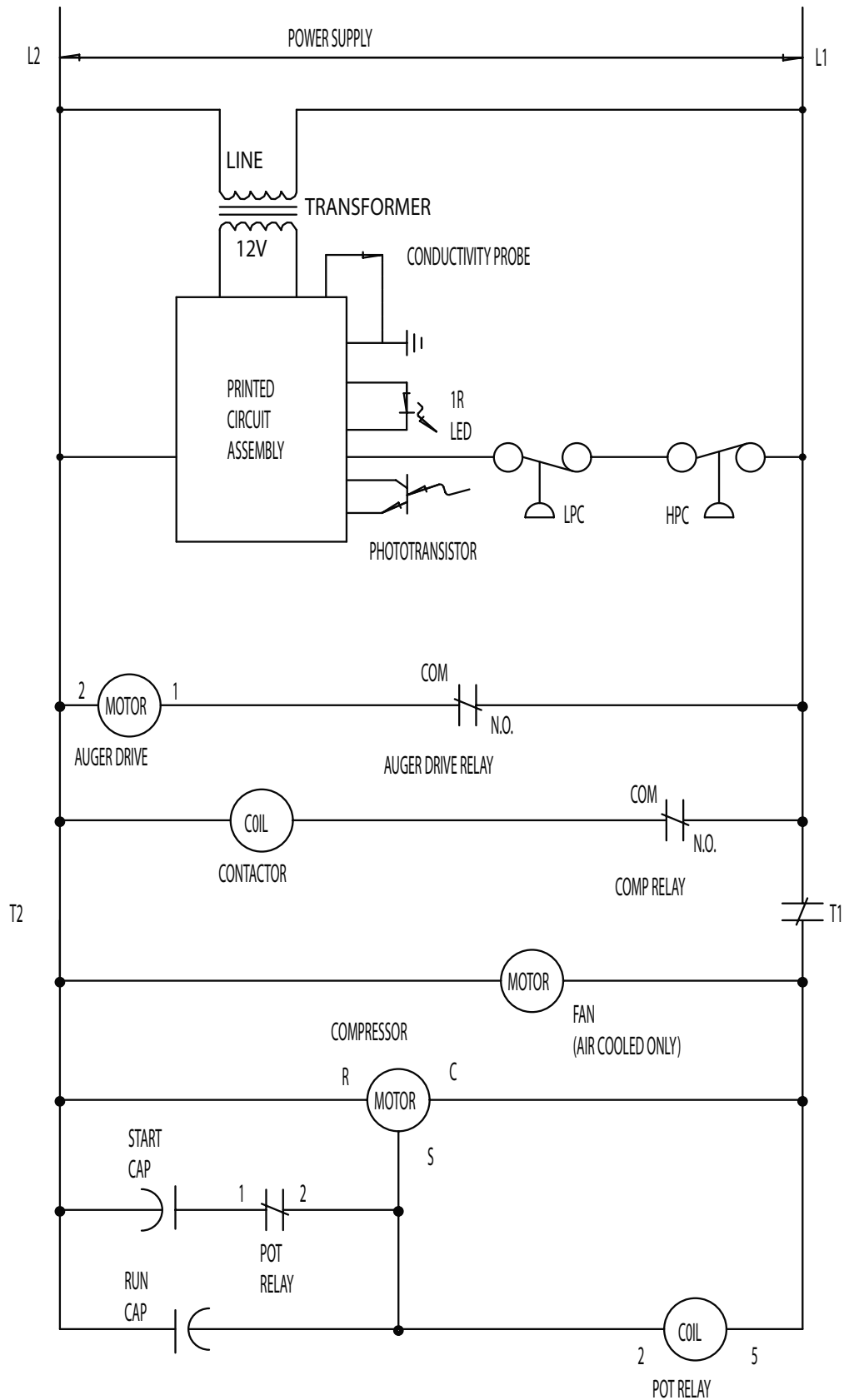

N0422, F0522, N0622, F0822, N0922, F1222, N1322, F1522 Service Parts

Wiring Diagram N0622, F0822, N0922, F1222, N1322 or F1522 Single Phase A or B Series

17-31 99-01

CAUTION:
MORE THAN ONE DISCONNECT MEANS MAY BE
REQUIRED TO DISCONNECT ALL POWER TO THIS UNIT.

- 1 WIRE COLOR FOR 115/60/1 UNITS: WHITE
WIRE COLOR FOR 208-230/60/1 UNITS: BLACK WITH WHITE STRIPE
- 2 WIRE COLOR FOR 208-230/60/1 UNITS: BLACK
- 3 WIRE COLOR FOR 115/60/1 UNITS: WHITE
WIRE COLOR FOR 208-230/60/1 UNITS: BLACK WITH WHITE STRIPE

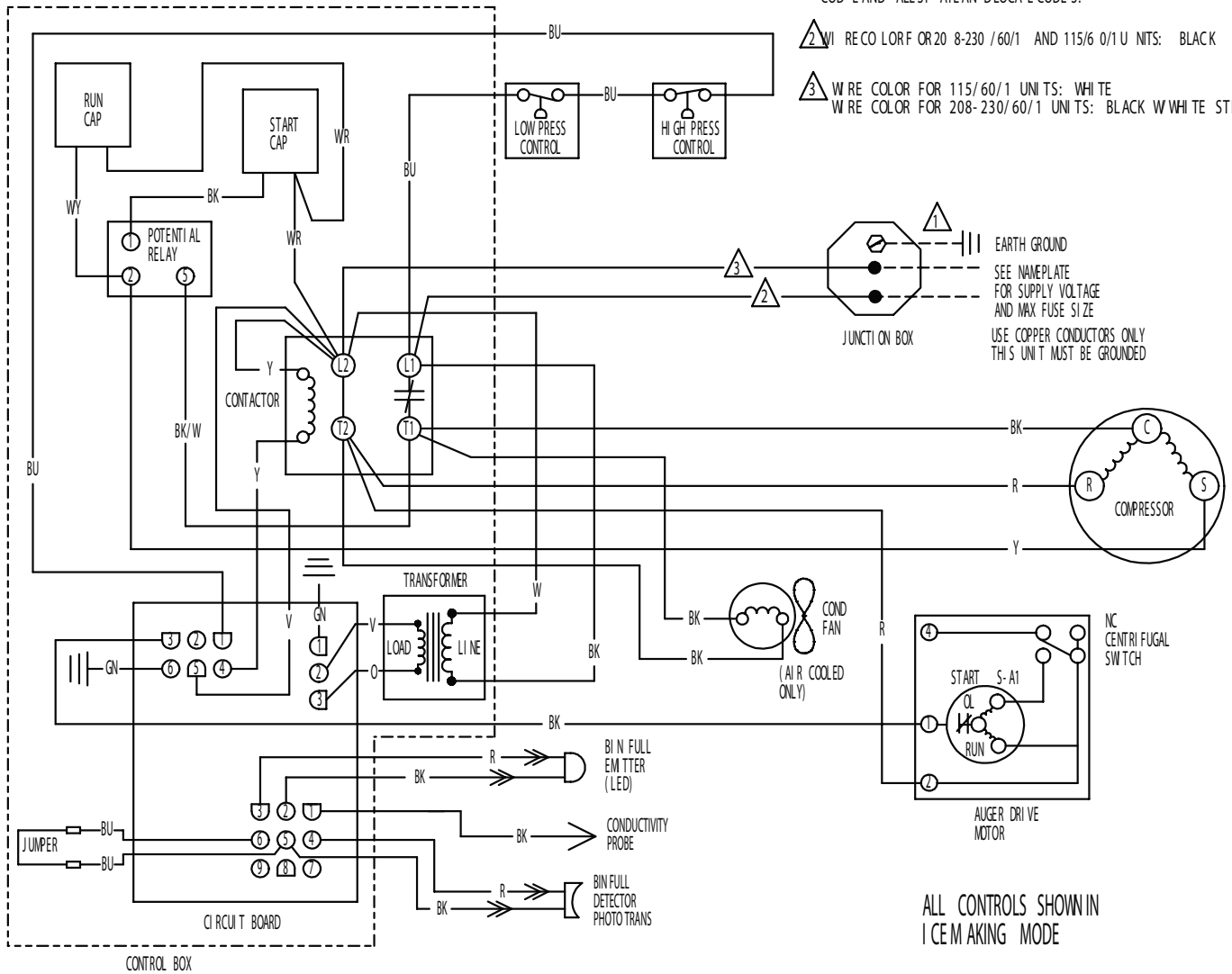

N0422, F0522, N0622, F0822, N0922, F1222, N1322, F1522 Service Parts

Schematic Diagram N0622, F0822, N0922, F1222, N1322 or F1522 Single Phase A or B Series

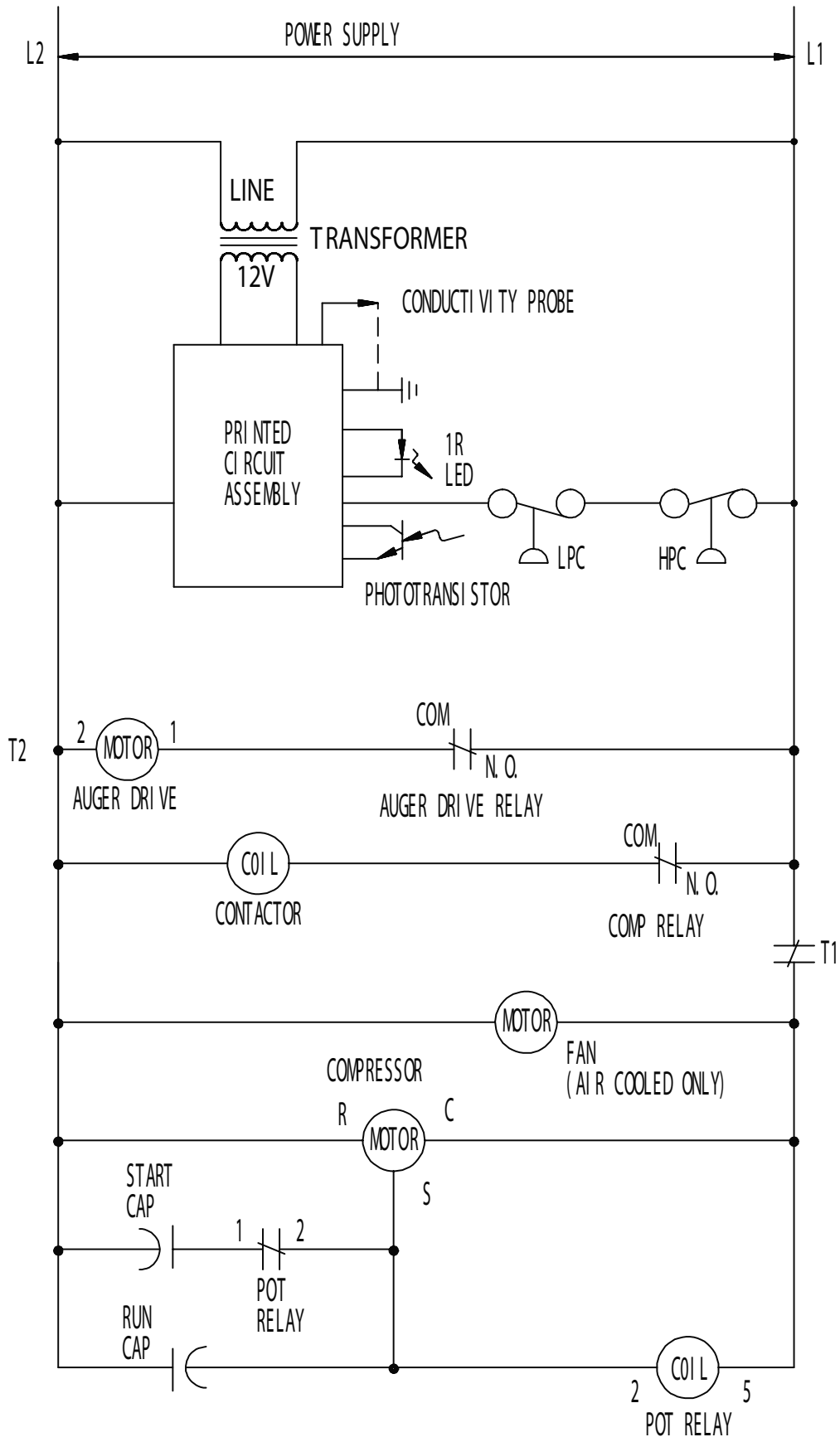

N0422, F0522, N0622, F0822, N0922, F1222, N1322, F1522

Service Parts

Wiring Diagram N0922, F1222, N1322 or F1522 Three Phase A or B Series

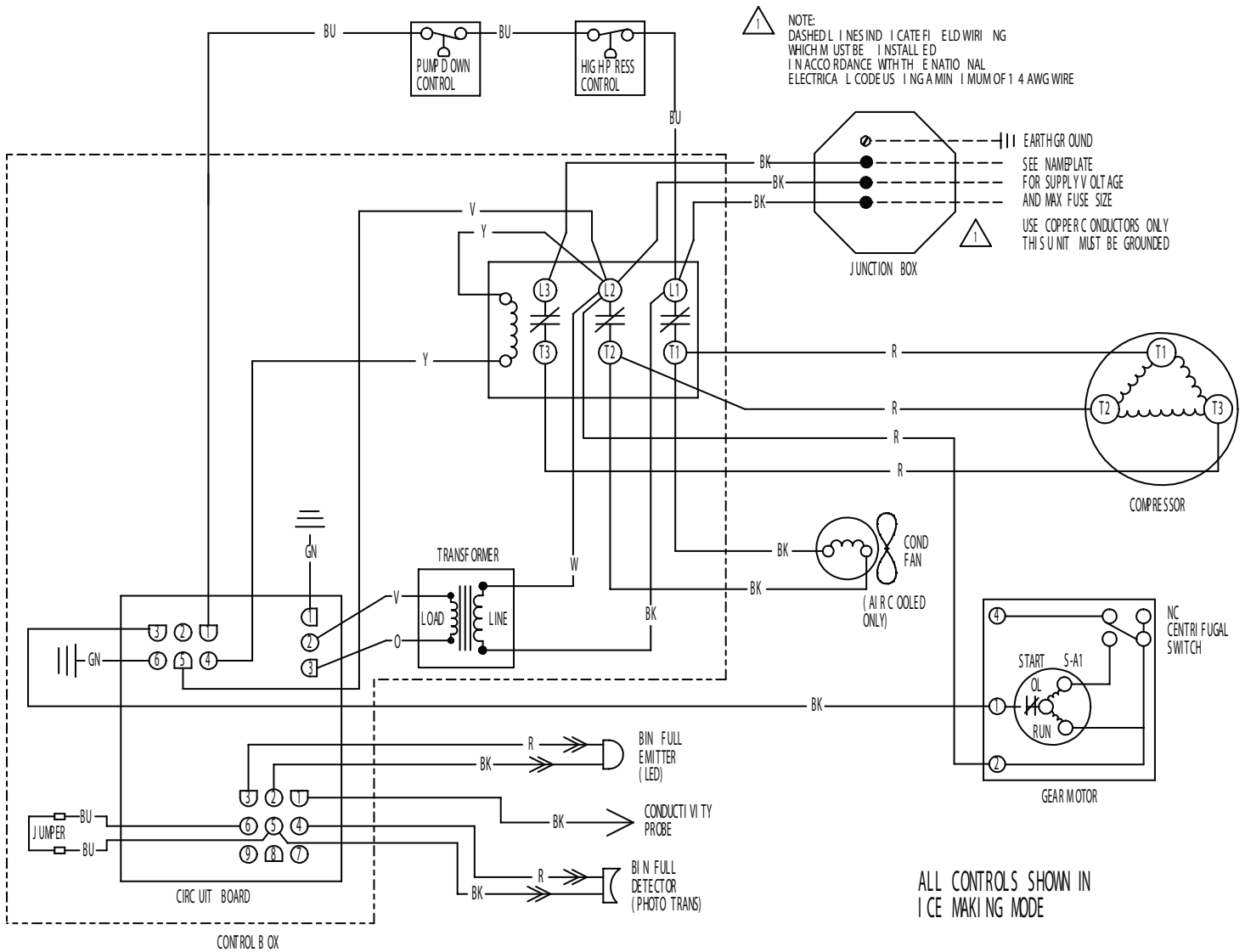

N0422, F0522, N0622, F0822, N0922, F1222, N1322, F1522 Service Parts

Schematic Diagram N0922, F1222, N1322 or F1522 Three Phase A or B Series

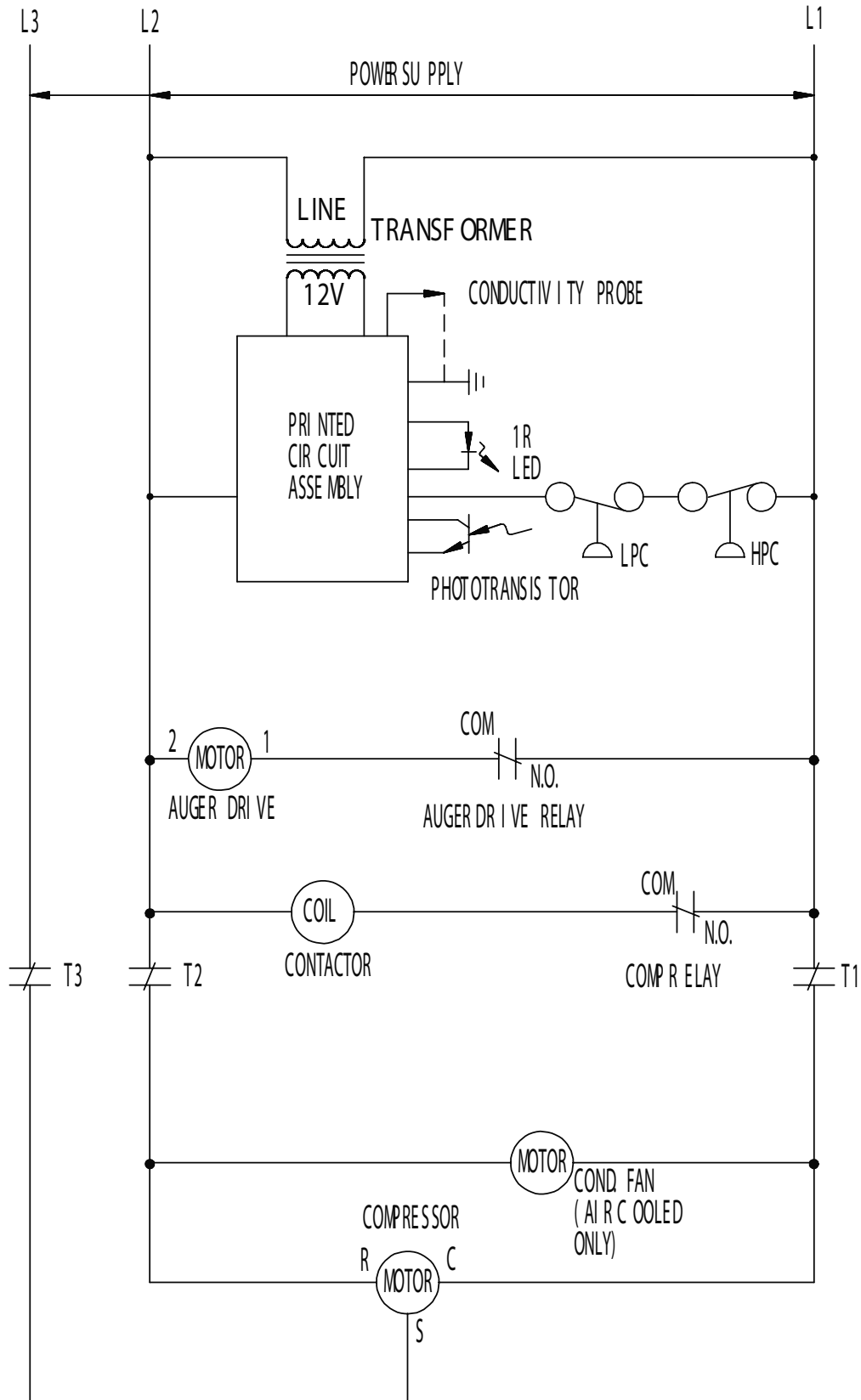

N0422, F0522, N0622, F0822, N0922, F1222, N1322, F1522

Service Parts

Wiring Diagram N0622, F0822, N0922, F1222, N1322, F1522 Remote Single Phase A or B Series

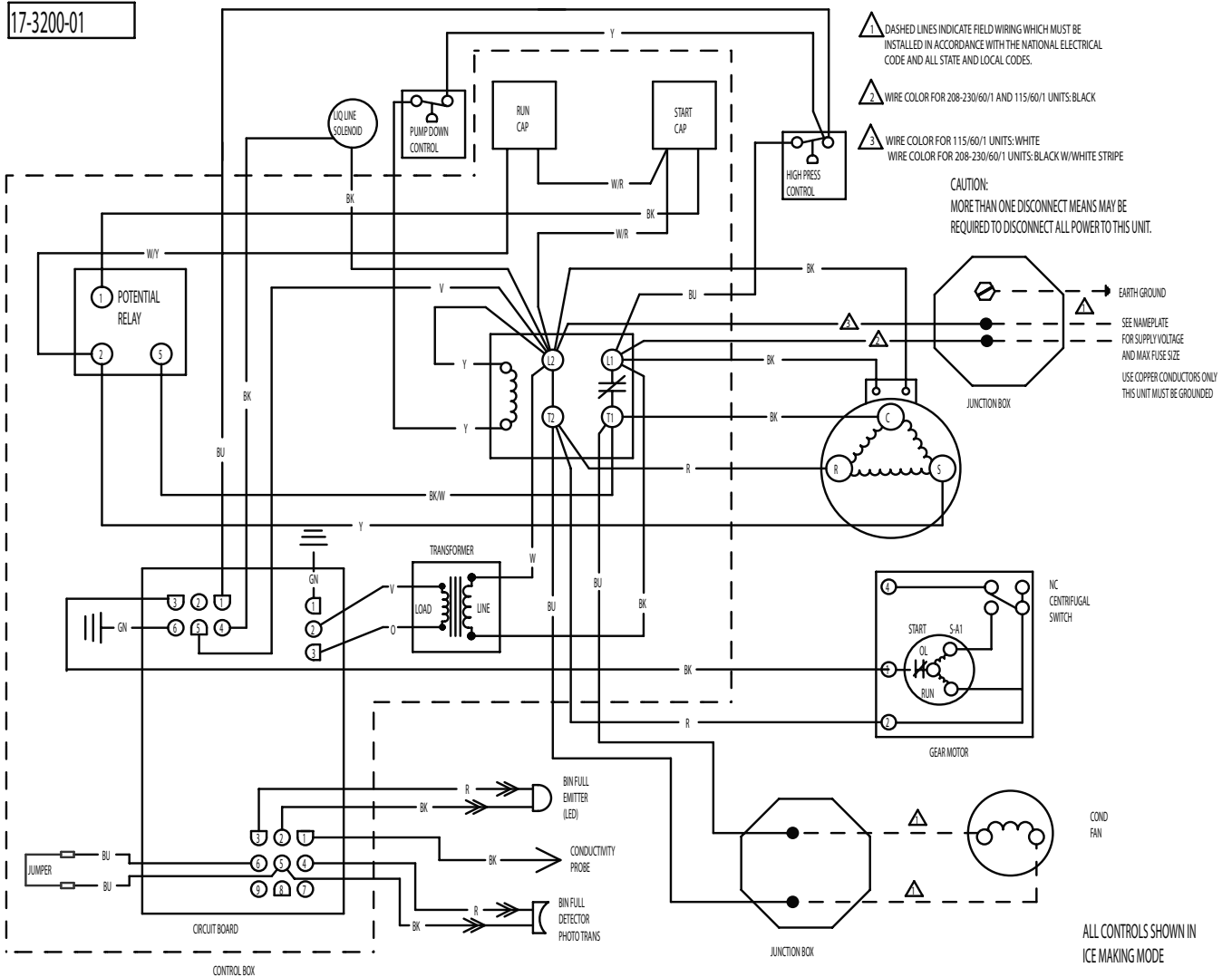

N0422, F0522, N0622, F0822, N0922, F1222, N1322, F1522

Service Parts

Schematic N0622, F0822, N0922, F1222, N1322, F1522 Remote Single Phase A or B Series

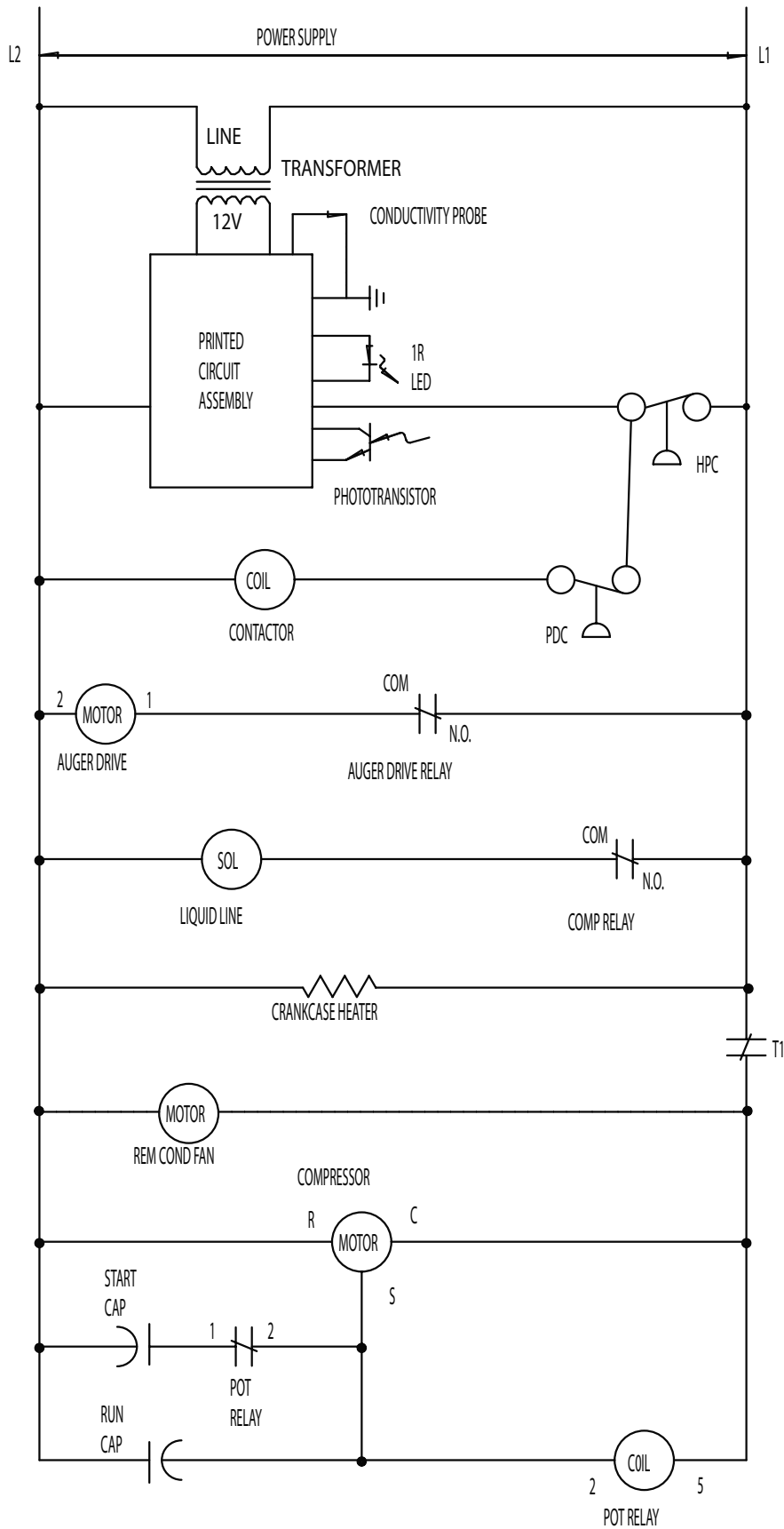

N0422, F0522, N0622, F0822, N0922, F1222, N1322, F1522

Service Parts

Wiring Diagram N0922, F1222, N1322 or F1522 Remote Three Phase A or B Series

17-3202-01

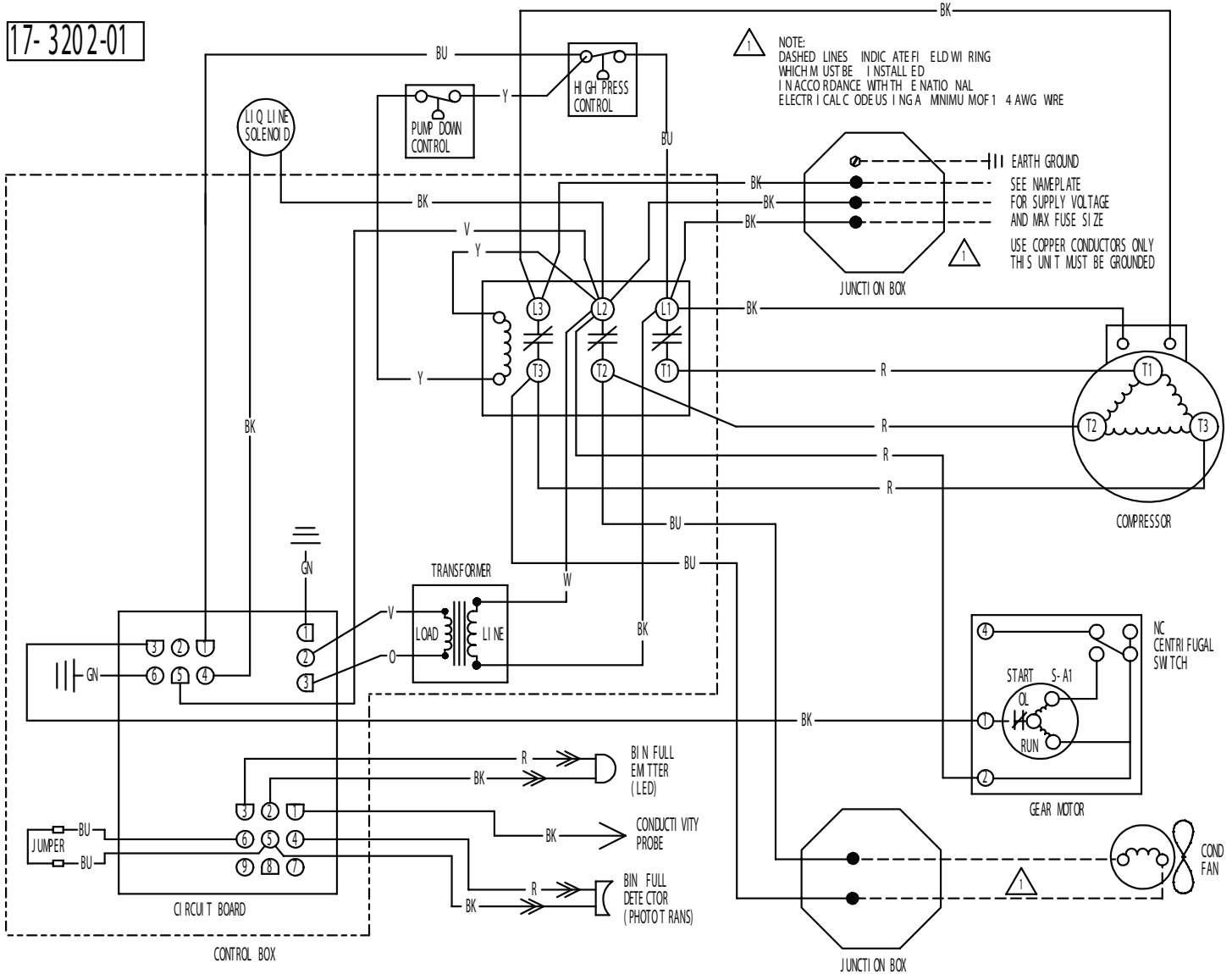

N0422, F0522, N0622, F0822, N0922, F1222, N1322, F1522

Service Parts

Schematic Diagram N0922, F1222, N1322 or F1522 Remote Three Phase A or B Series

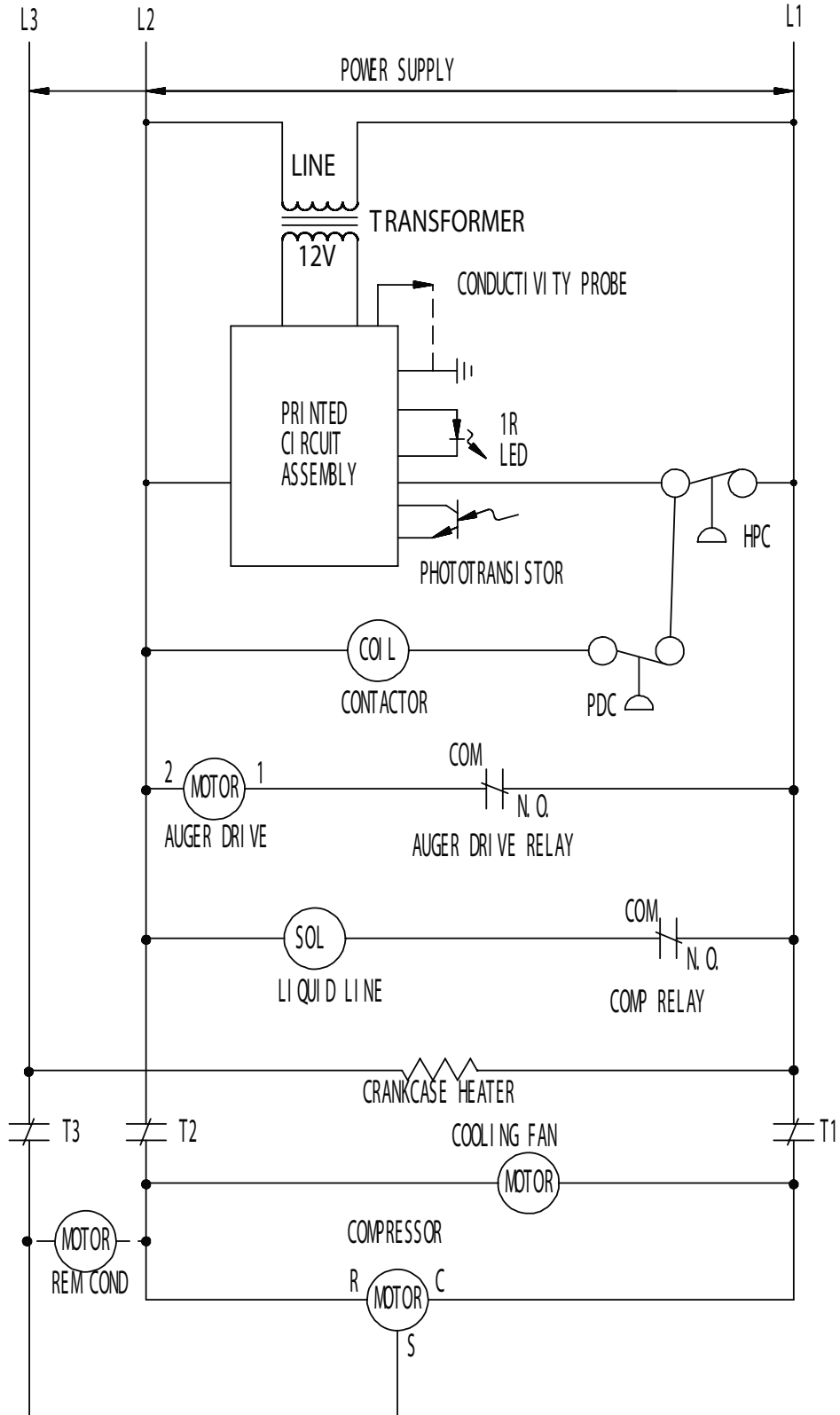

ALL CONTROLS SHOWN IN
ICE MAKING MODE

N0422, F0522, N0622, F0822, N0922, F1222, N1322, F1522

Service Parts

N0622, F0822, N0922 or F1222 50 Hz Wiring Diagram A or B Series

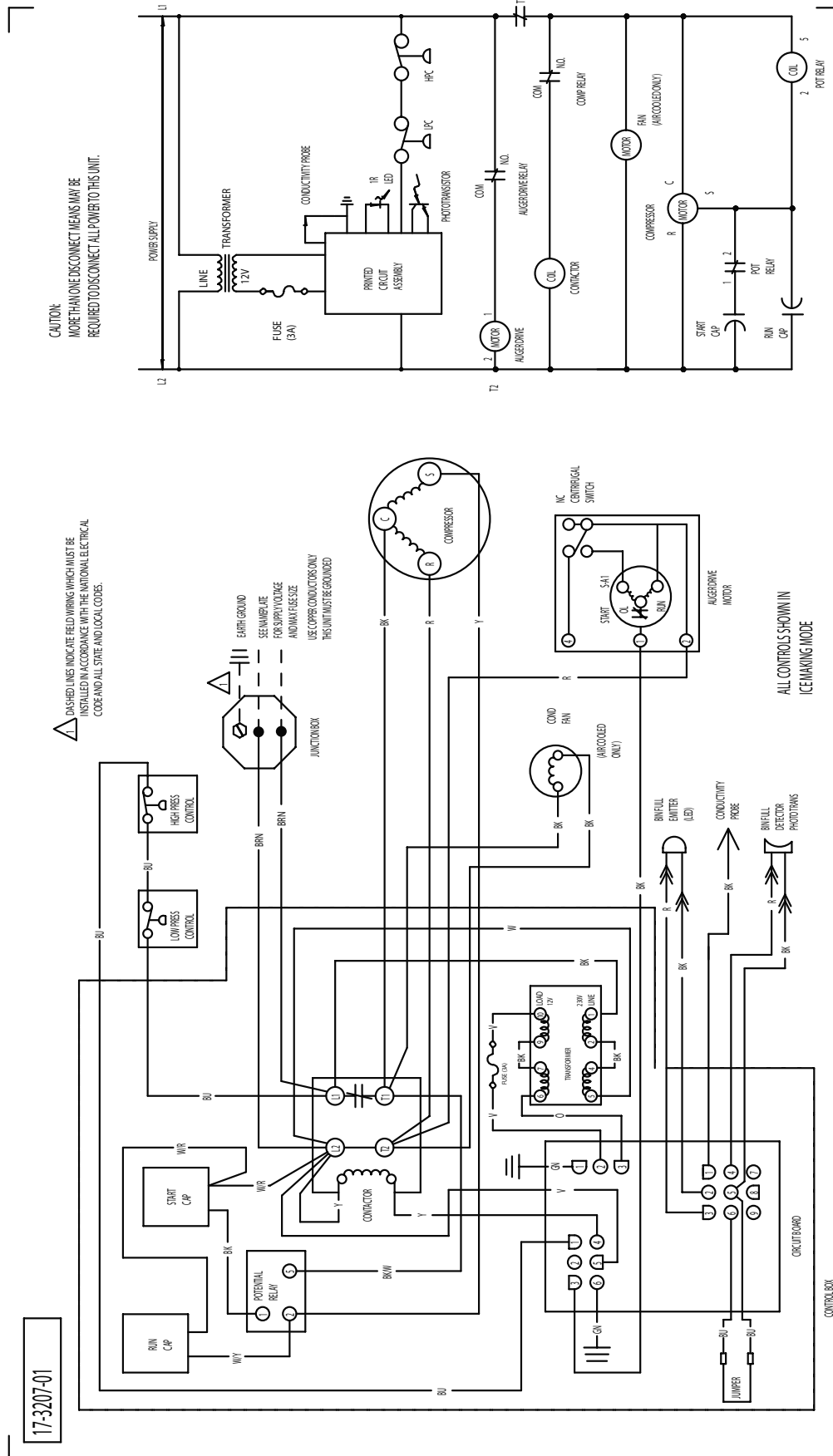

N0422, F0522, N0622, F0822, N0922, F1222, N1322, F1522

Service Parts

Wiring Diagram N0422 and F0522 D Series

17-3541-01

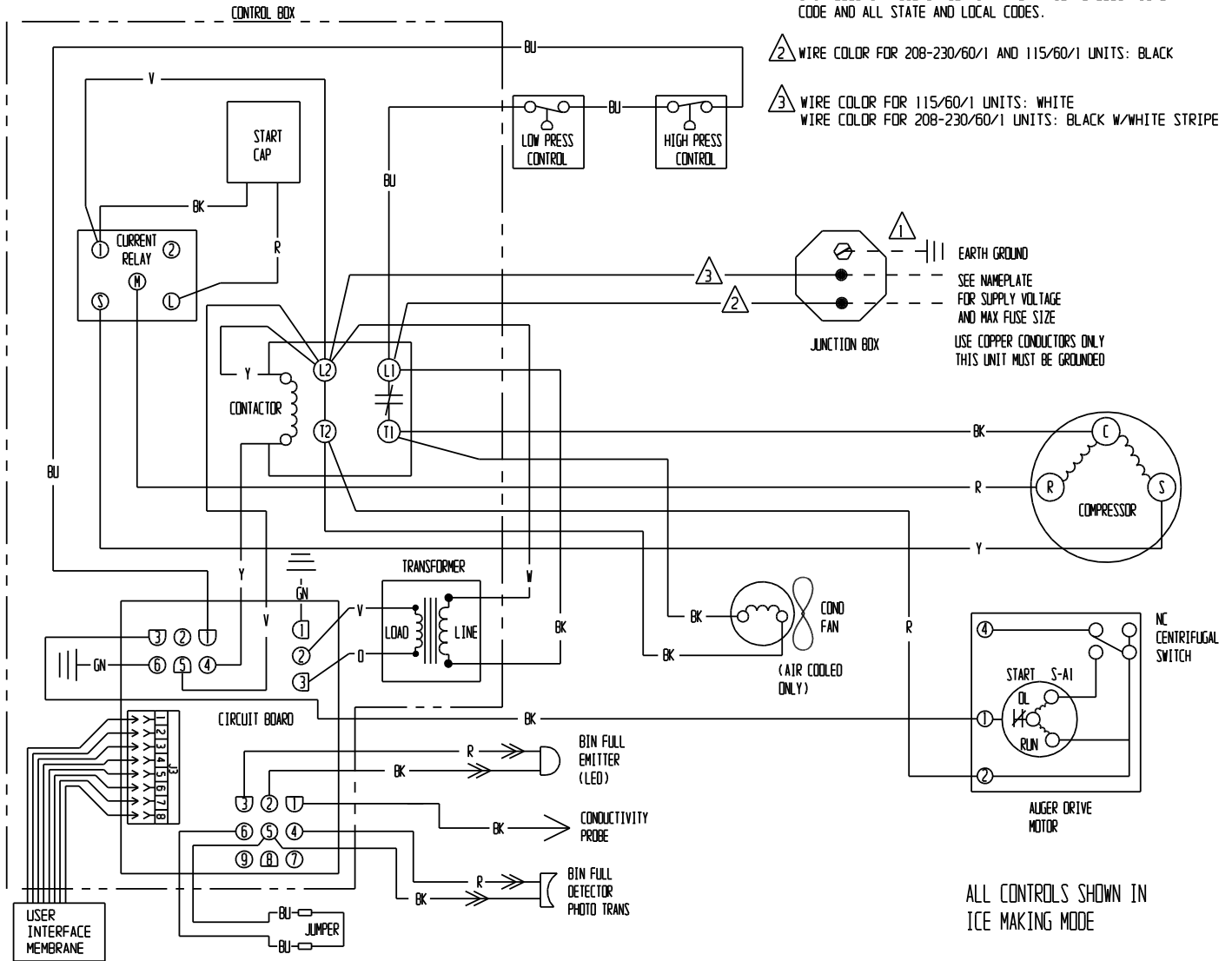

N0422, F0522, N0622, F0822, N0922, F1222, N1322, F1522

Service Parts

Schematic Diagram N0422 or F0522 D Series

CAUTION:
 MORE THAN ONE DISCONNECT MEANS MAY BE
 REQUIRED TO DISCONNECT ALL POWER TO THIS UNIT.

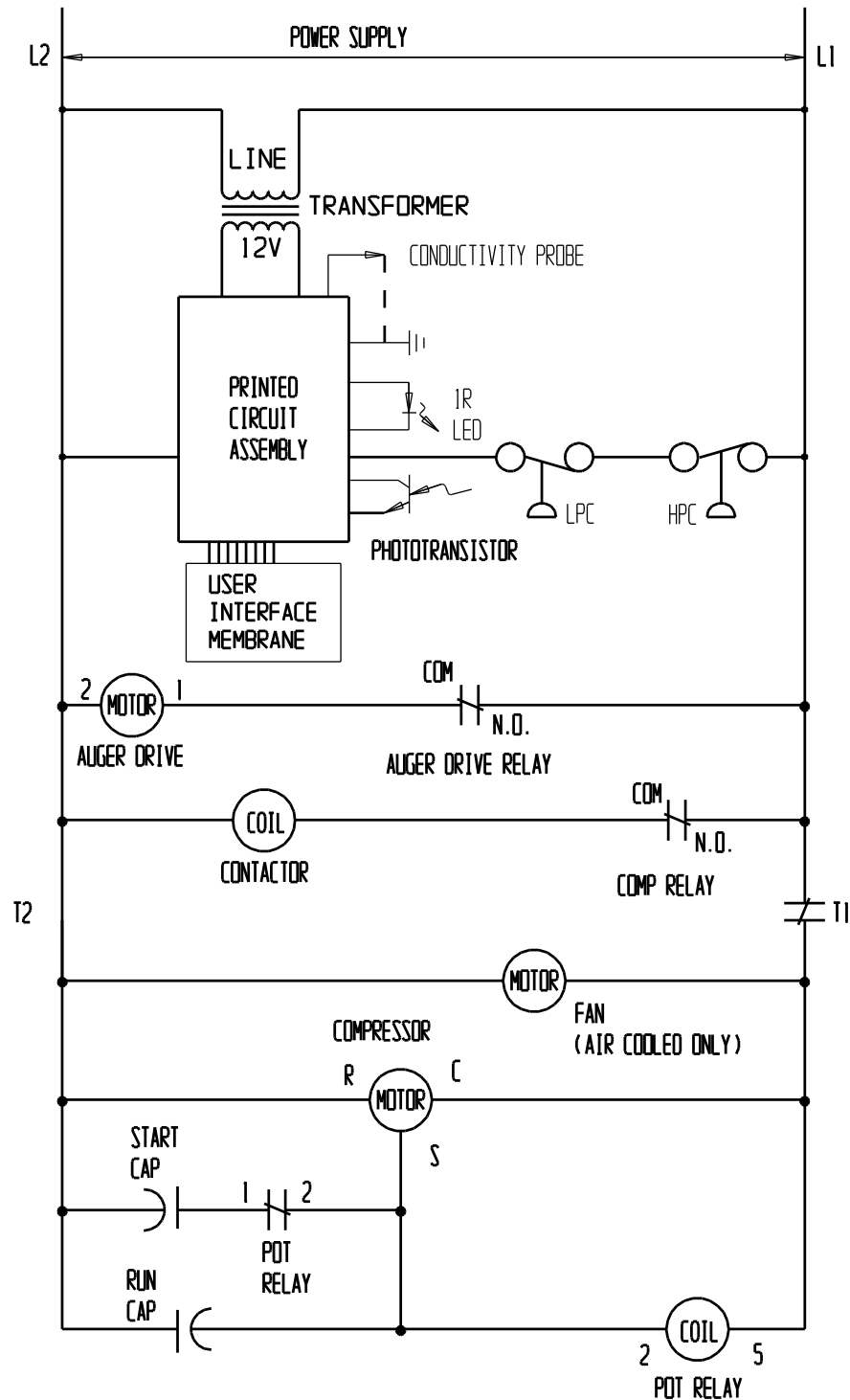

N0422, F0522, N0622, F0822, N0922, F1222, N1322, F1522 Service Parts

Wiring Diagram N0622, F0822, N0922, F1222, N1322 or F1522 Single Phase D Series

17-3527-01

CAUTION:
MORE THAN ONE DISCONNECT MEANS MAY BE
REQUIRED TO DISCONNECT ALL POWER TO THIS UNIT.

⚠ DASHED LINES INDICATE FIELD WIRING WHICH MUST BE
INSTALLED IN ACCORDANCE WITH THE NATIONAL ELECTRICAL
CODE AND ALL STATE AND LOCAL CODES.

⚠ WIRE COLOR FOR 208-230/60/1 AND 115/60/1 UNITS: BLACK

⚠ WIRE COLOR FOR 115/60/1 UNITS: WHITE
WIRE COLOR FOR 208-230/60/1 UNITS: BLACK W/WHITE STRIPE

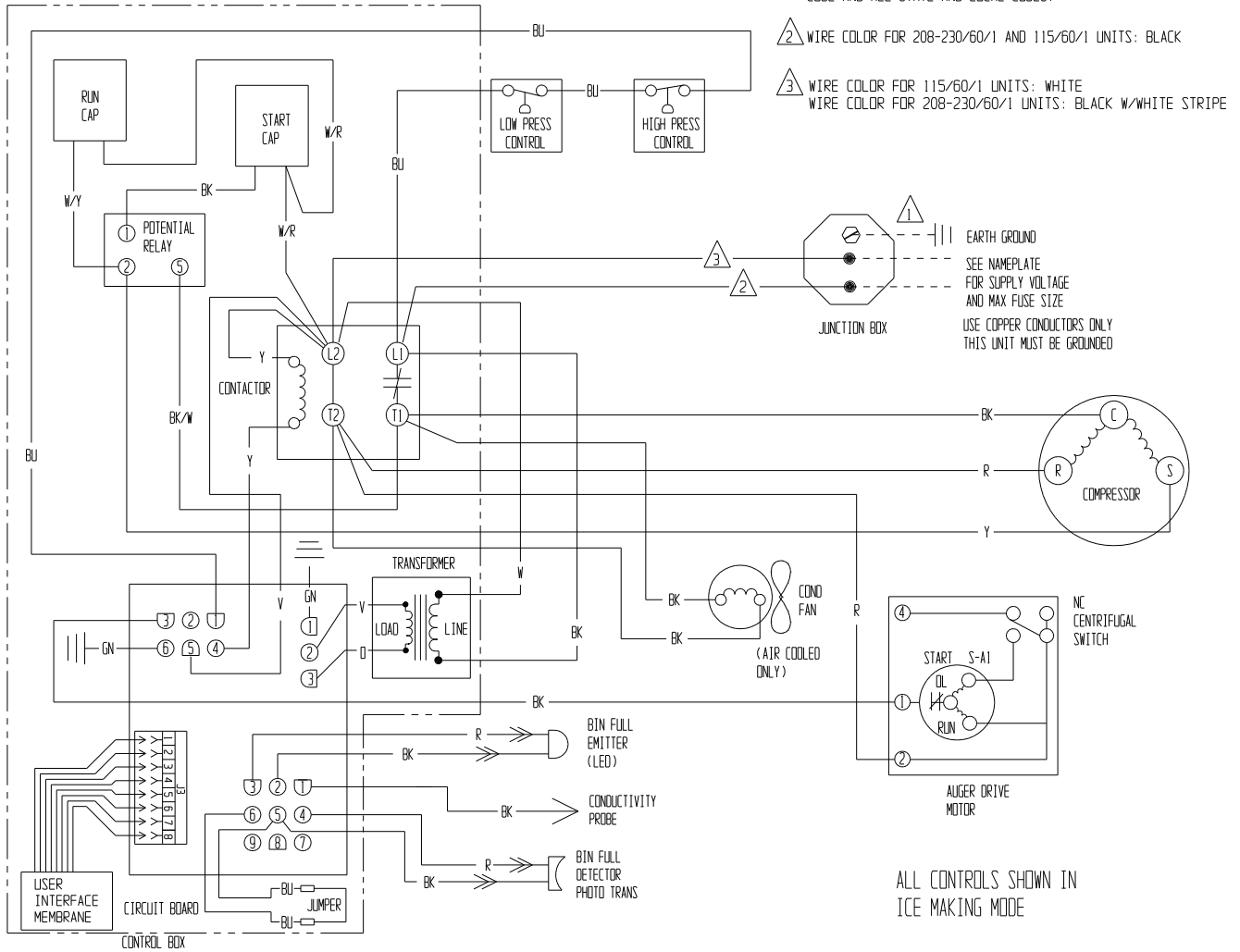

N0422, F0522, N0622, F0822, N0922, F1222, N1322, F1522 Service Parts

Schematic Diagram N0622, F0822, N0922, F1222, N1322 or F1522 Single Phase D Series

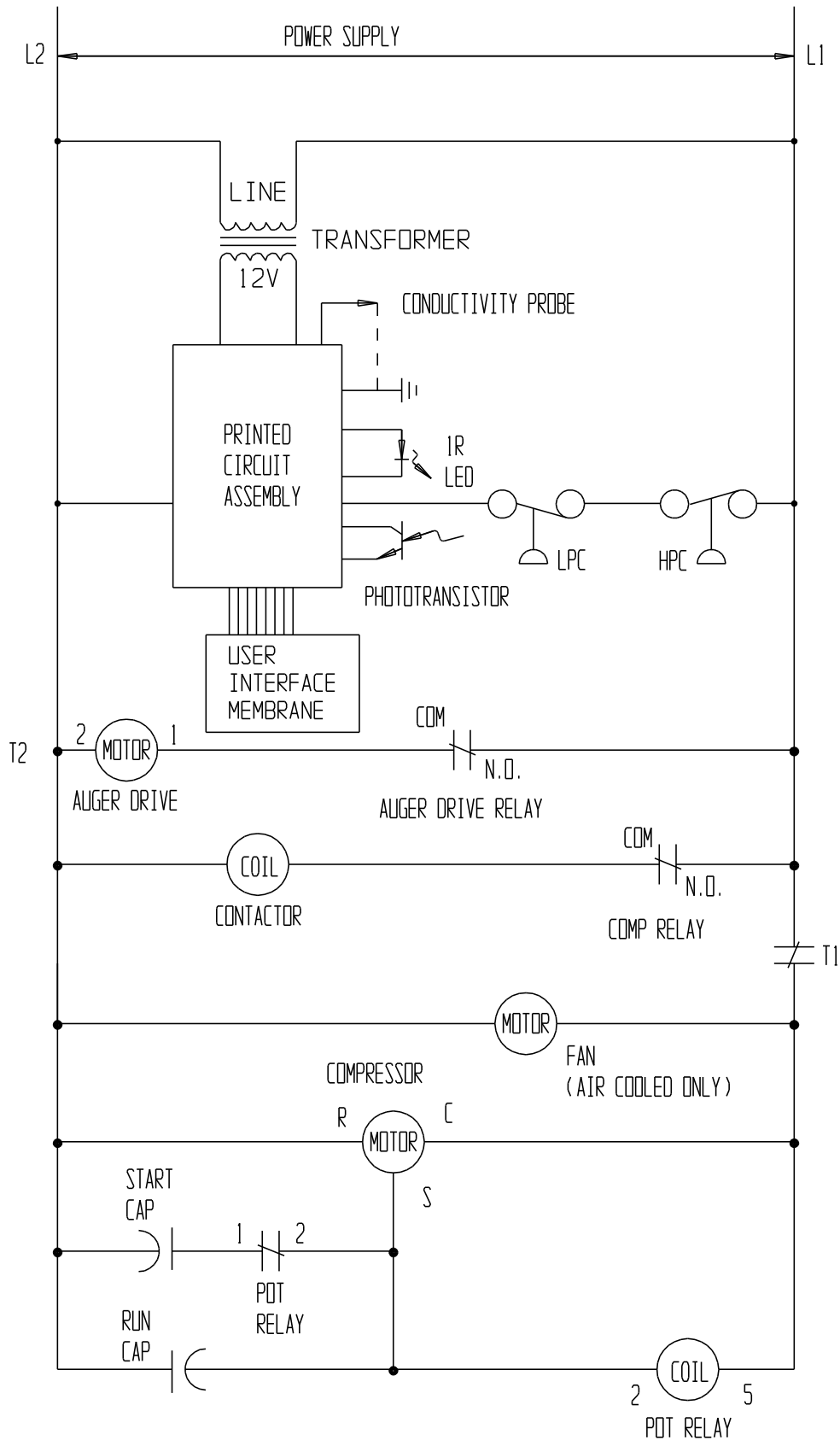

N0422, F0522, N0622, F0822, N0922, F1222, N1322, F1522

Service Parts

Wiring Diagram F1222, N1322 Three Phase D Series

17-3529-01

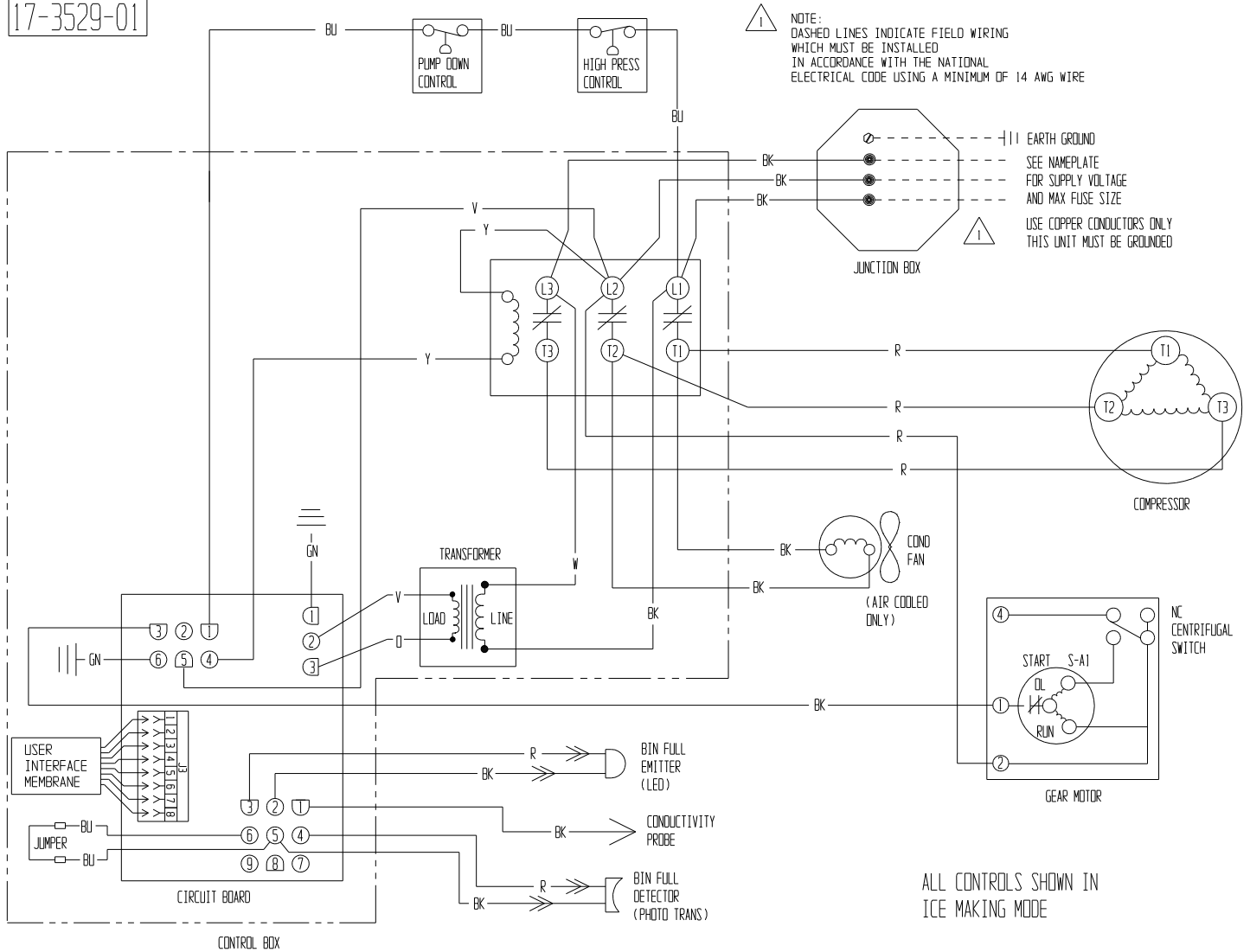

N0422, F0522, N0622, F0822, N0922, F1222, N1322, F1522

Service Parts

Schematic Diagram F1222, N1322 Three Phase D Series

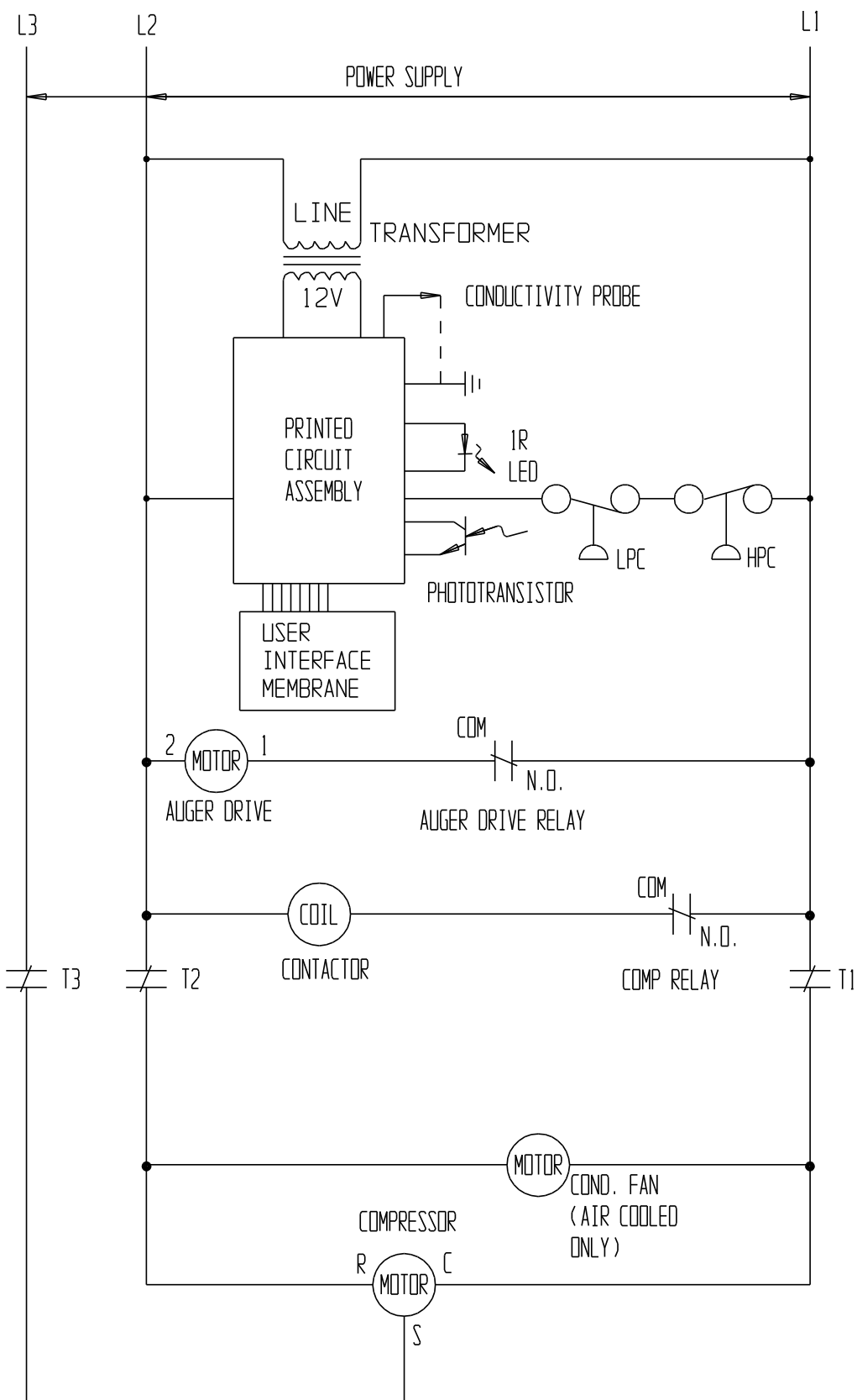

N0422, F0522, N0622, F0822, N0922, F1222, N1322, F1522 Service Parts

Wiring Diagram N0622, F0822, N0922, F1222, N1322 Remote Single Phase D Series

17-3528-01

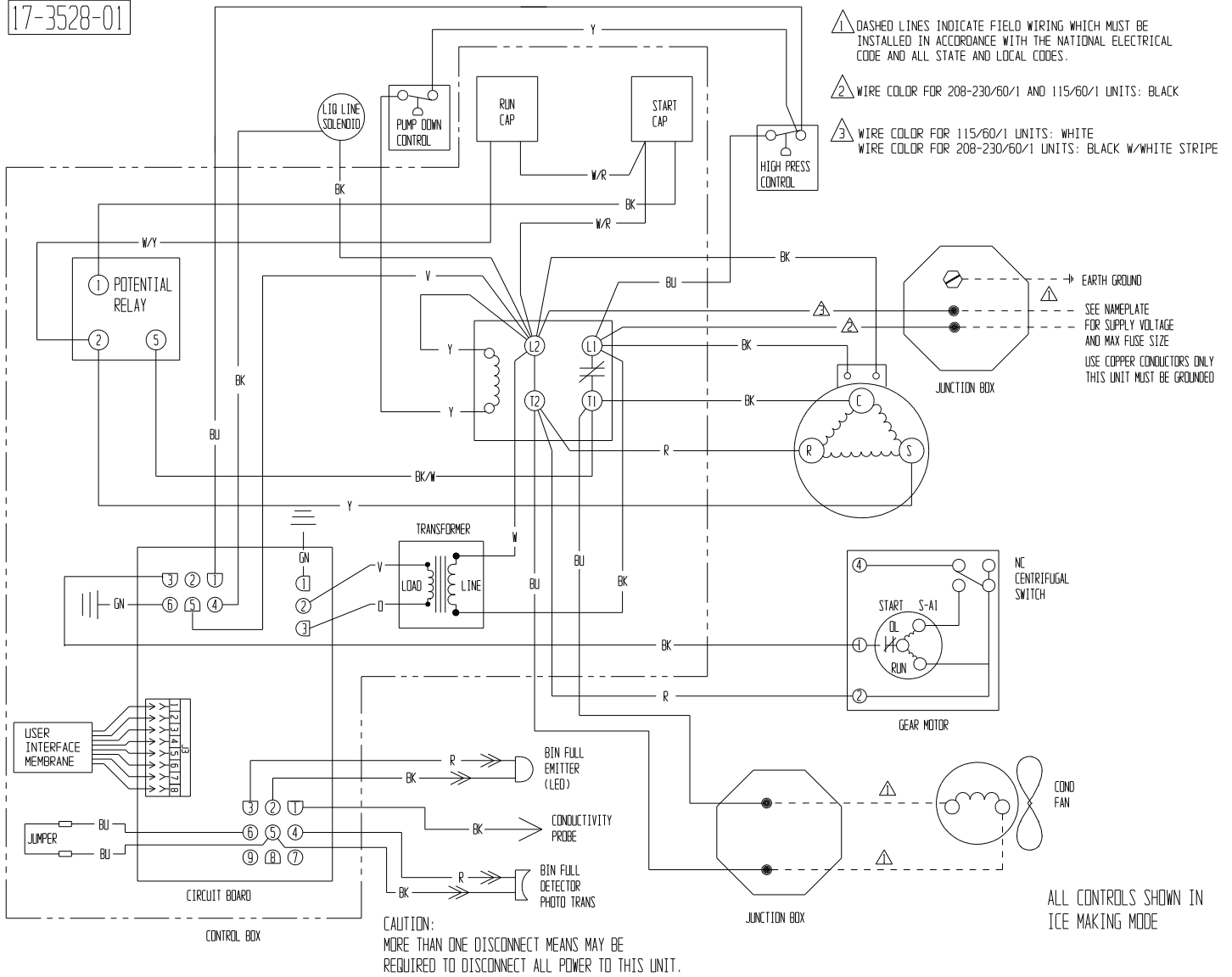

N0422, F0522, N0622, F0822, N0922, F1222, N1322, F1522

Service Parts

Schematic Diagram N0622, F0822, N0922, F1222, N1322 Remote Single Phase D Series

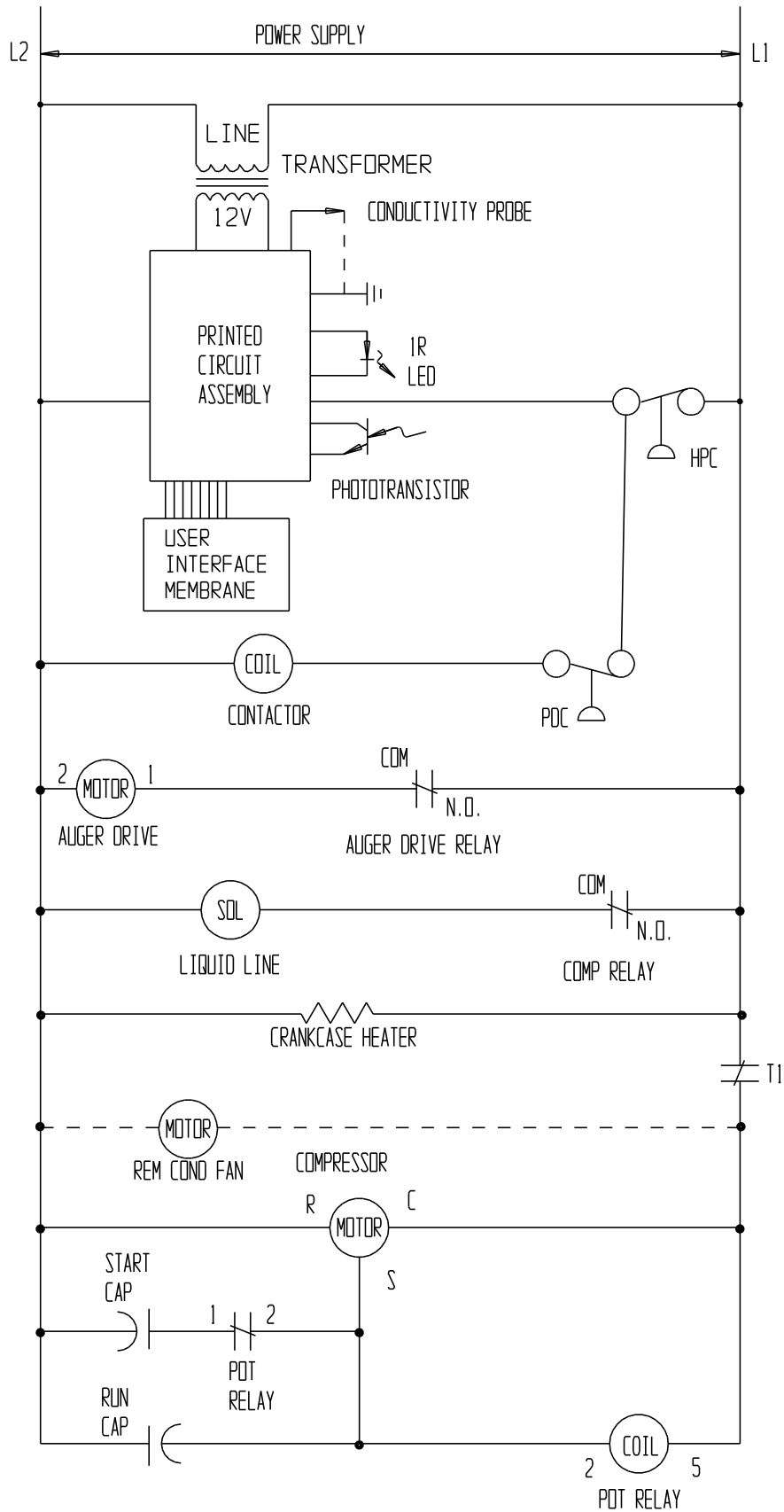

N0422, F0522, N0622, F0822, N0922, F1222, N1322, F1522

Service Parts

Wiring Diagram F1222 Remote Three Phase D Series

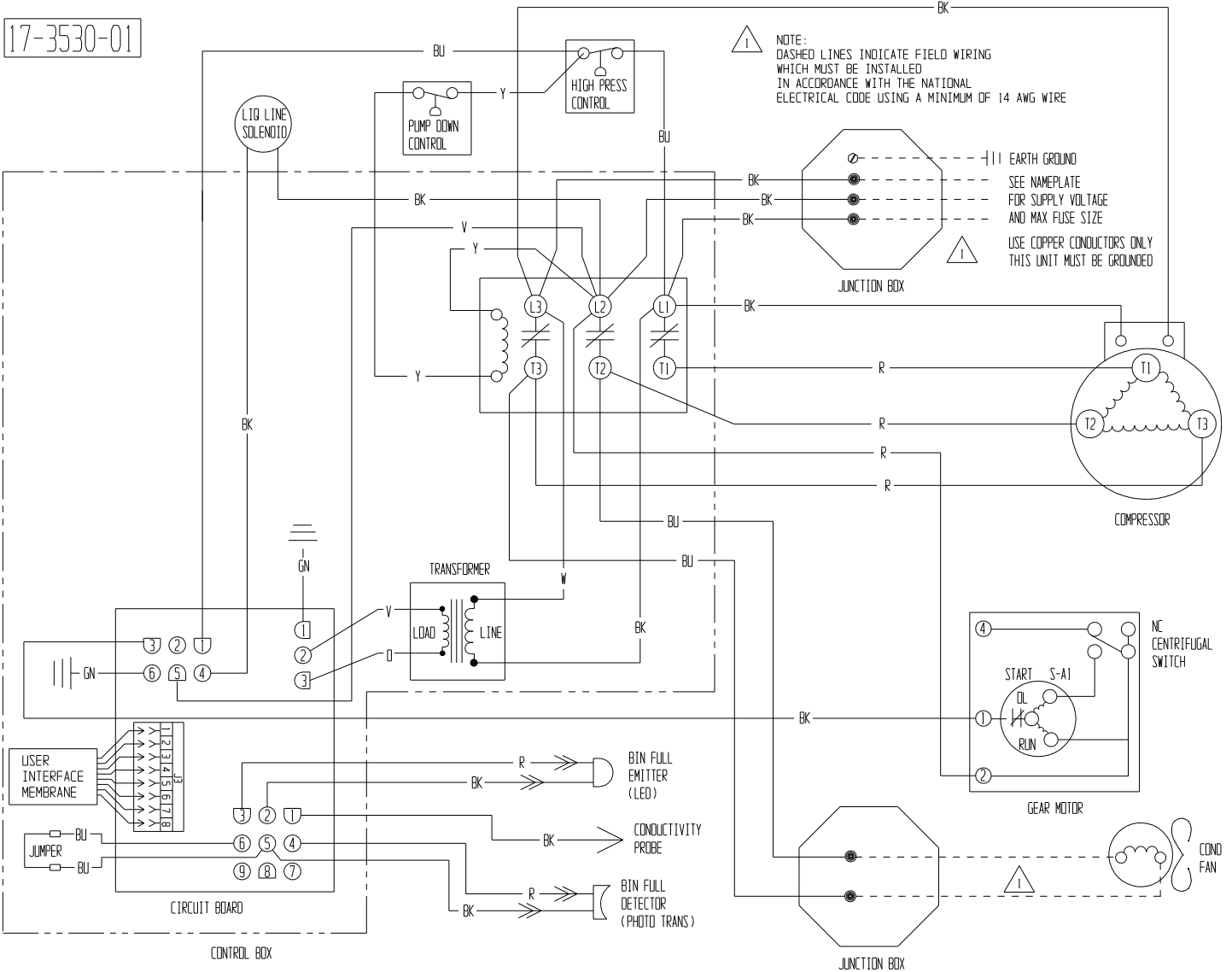

N0422, F0522, N0622, F0822, N0922, F1222, N1322, F1522

Service Parts

Schematic Diagram F1222 Remote Three Phase D Series

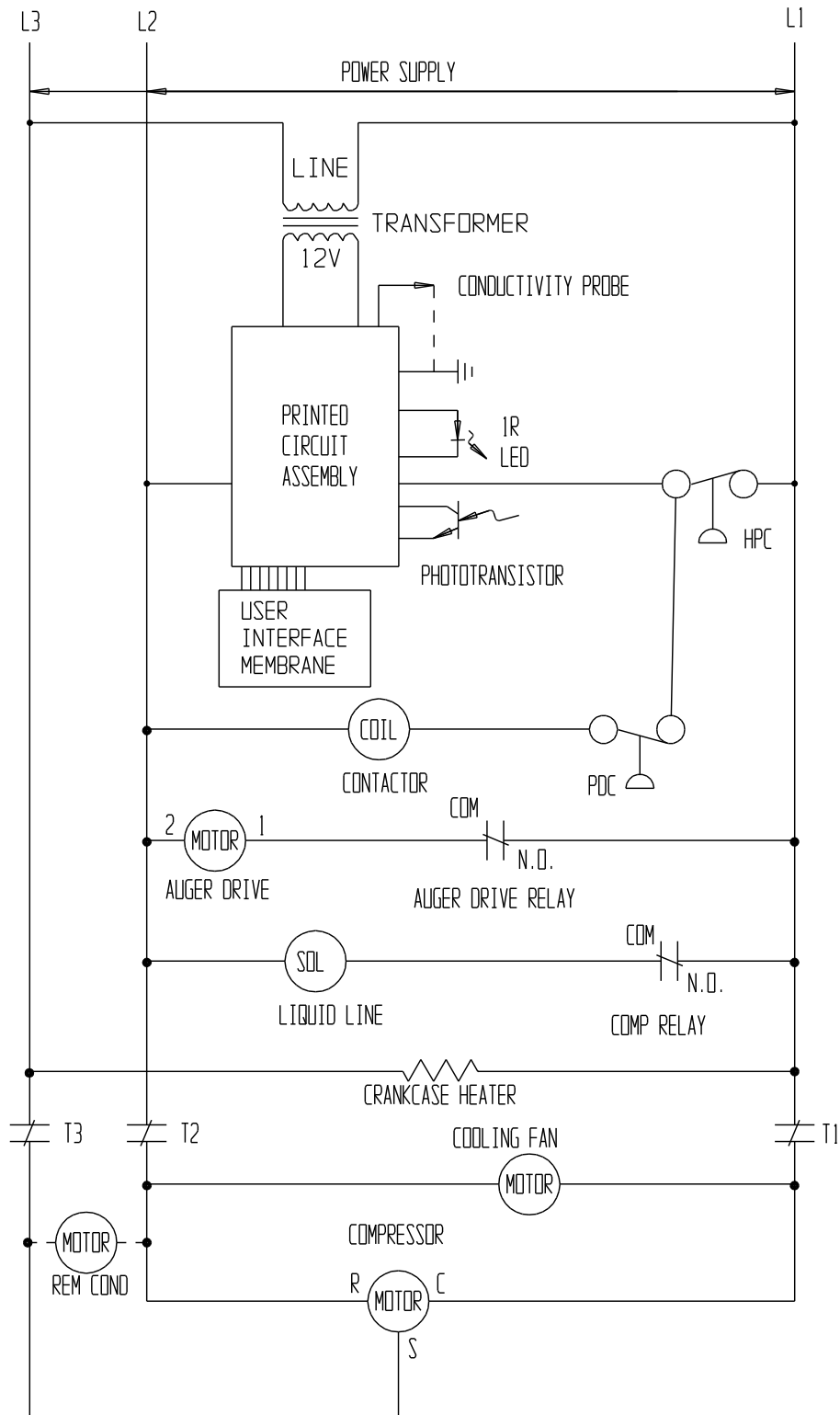

ALL CONTROLS SHOWN IN
ICE MAKING MODE

N0422, F0522, N0622, F0822, N0922, F1222, N1322, F1522

Service Parts

N0622, N0922 or F1222 50 Hz Wiring Diagram D Series

