

NDE754 SERVICE PARTS

This parts list contains the service parts and wiring diagrams for this model. Check the model number of the machine needing parts to be sure that this is the correct parts list.

Note: The liquid line filter drier listed in this parts list is designed for this refrigeration system. Premature failure may result if the wrong drier is used.

Table Of Contents

Cabinet	page 2
Hopper	page 3
Vend Assembly	page 4
Ice Chute and Dispensing	page 5
Air Cooled Refrigeration	page 6
Water Cooled Refrigeration	page 7
Water System	page 8
Evaporator	page 9
Gearmotor	page 10
Control Box	page 11
Wiring Diagram	page 12
Schematic Diagram	page 13

NDE754 SERVICE PARTS

Cabinet

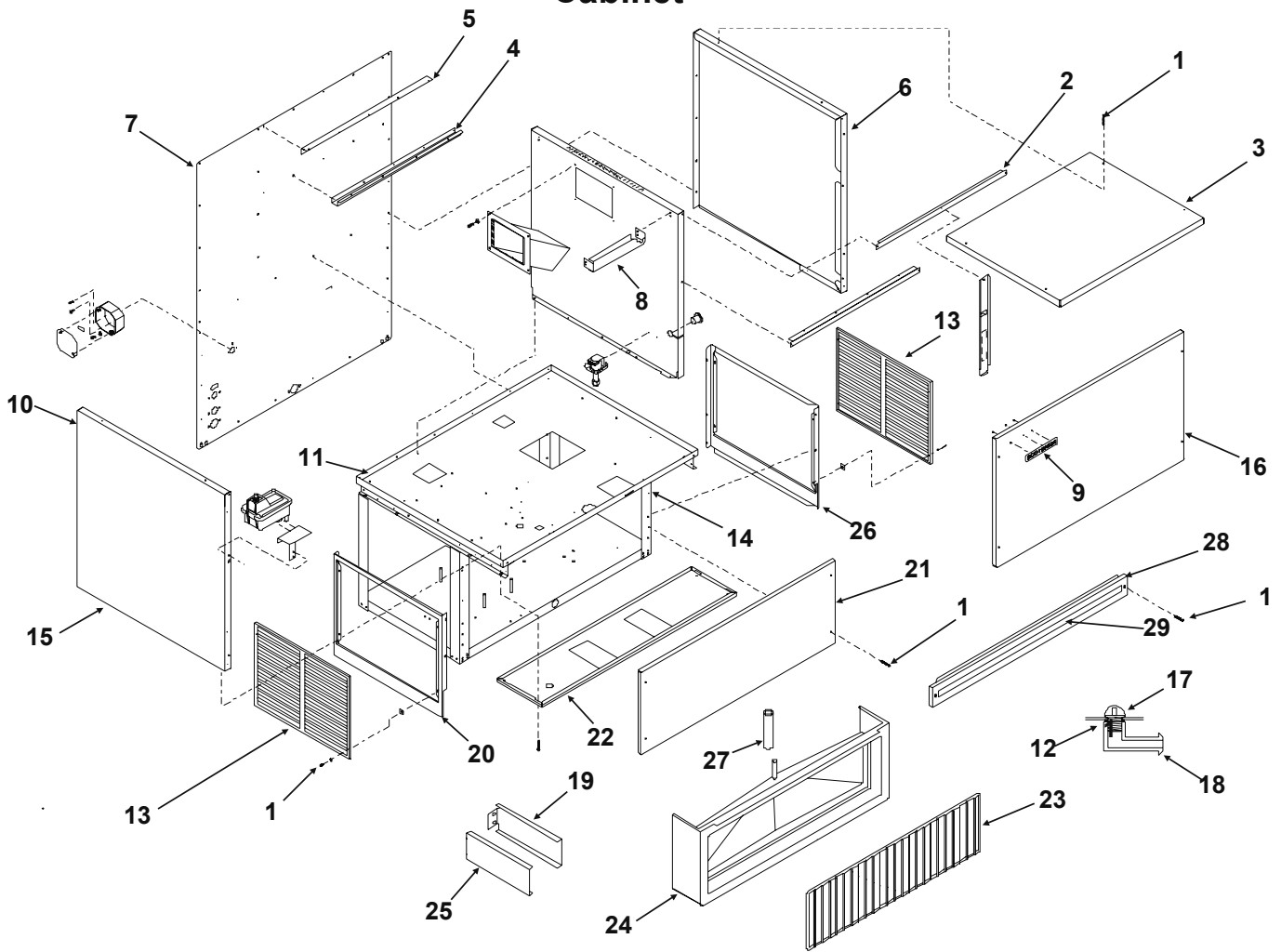

ITEM NUMBER	PART NUMBER	DESCRIPTION
1	03-1419-22	S.S. Screw
2	A34563-001	Upper Brace
3	A33282-002	Top panel, stainless
4	A34625-015	Bin support
5	A33270-015	Bin support brace
6	A34414-002	Rt. side upper panel
7	A33276-002	Back panel, stainless
8	A33269-015	Upper brace
9	15-0808-01	Emblem
10	03-1531-01	Screw
11	A33285-015	Upper Plate
12	13-0617-11	O-ring
13	A33281-002	Service Panel, stainless
14	A33280-001	Lower frame assy
15	A33283-002	Left side panel, upper
16	A34441-001	Upper front panel, s s
17	A34561-001	Front pnl, ss, gov'mt mod
18	02-2809-01	Drain top
19	02-1742-00	Drain btm
20	A34401-016	Right sink support
21	03-1645-01	Screw 1/4 20 x 1/2"
22	A33284-002	Lower left side panel
23	A34477-001	Splash panel
24	A34443-002	Ice chute panel, s. s.
25	02-2582-01	Grill
26	A31047-022	Sink, gray includes items 12, 17, 18
27	A34401-015	Sink support left
28	03-1645-01	Screw 1/4 20 x 1/2"
29	A33284-004	Rt. side lower panel
	A20250-003	Tube
	A34573-001	Spout cover s s
	15-0747-01	Decal

NDE754 SERVICE PARTS

Hopper

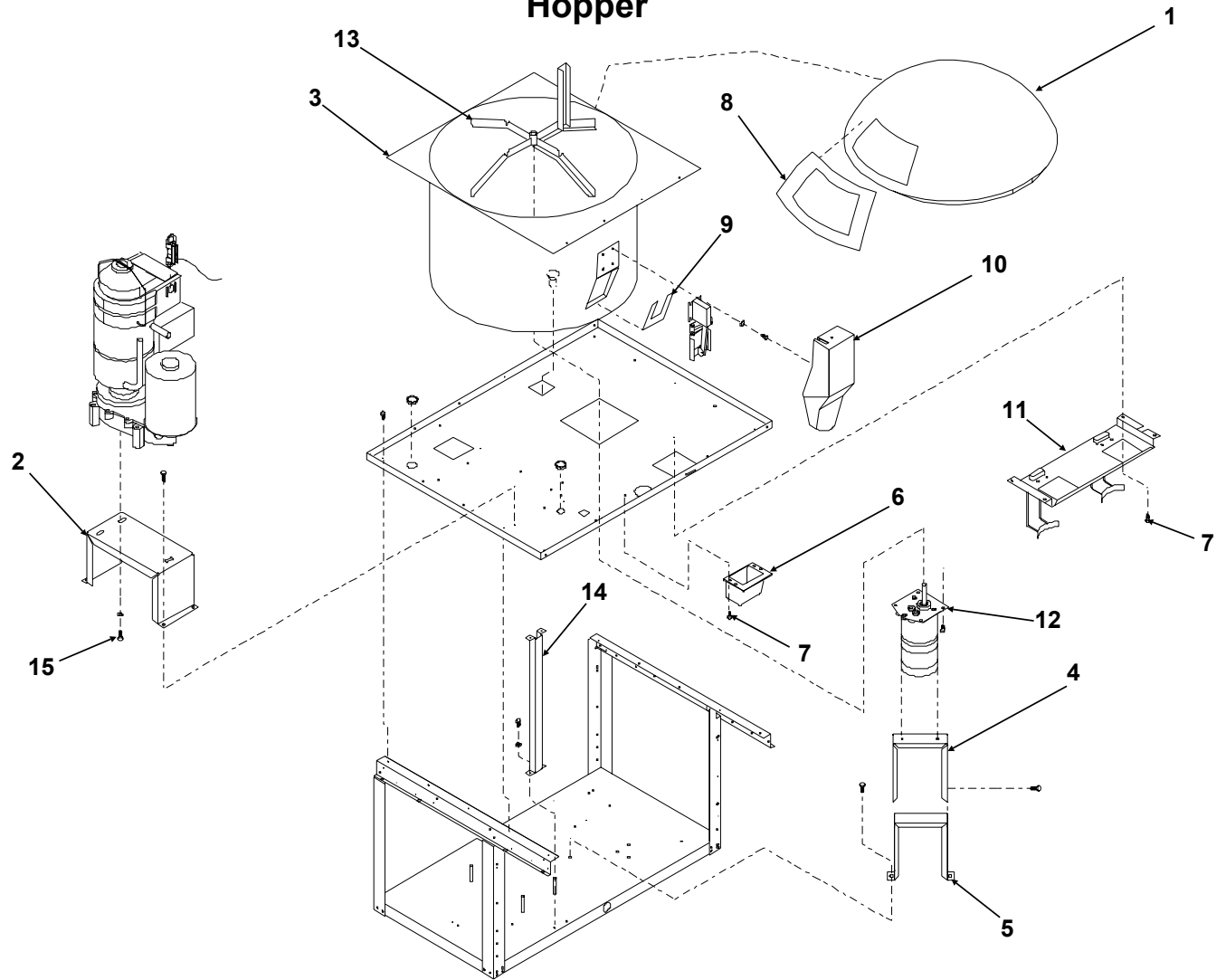

ITEM NUMBER	PART NUMBER	DESCRIPTION
1	A34957-001	Ice bin cover
2	A33287-015	Evap. support bracket
3	A34016-001	Ice Storage Bin
4	A34508-001	Agit mtr support, upper
5	A34509-001	Agit mtr support, lower
6	A34578-002	Water Chute
7	03-1531-01	Screw
8	13-0875-01	Grommet
9	02-3233-01	Door gasket
10	A35321-001	Ice chute
11	see next page	
12	12-2368-01	Dispense motor assembly
	A32672-001	Heater for dispense gear motor
13	02-3116-01	Agitator
14	A33271-015	Brace
15	03-1405-17	Screw

NDE754 SERVICE PARTS

Vend Assembly

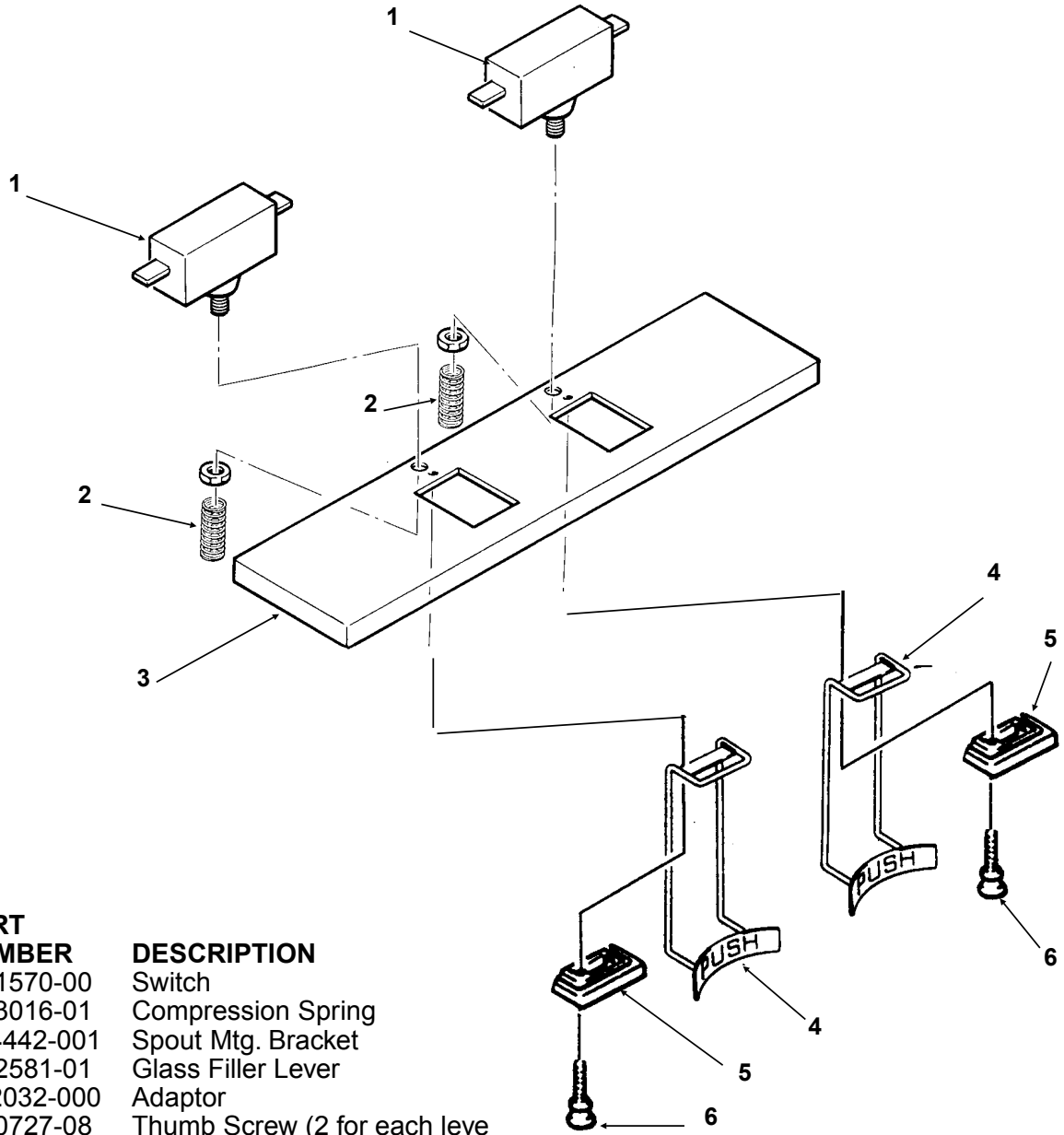

ITEM NUMBER	PART NUMBER	DESCRIPTION
1	12-1570-00	Switch
2	02-3016-01	Compression Spring
3	A34442-001	Spout Mtg. Bracket
4	02-2581-01	Glass Filler Lever
5	A22032-000	Adaptor
6	03-0727-08	Thumb Screw (2 for each leve

KPC750 Portion Control Kit Service Parts - Not Illustrated

ITEM NUMBER	PART NUMBER	DESCRIPTION
1	12-2360-01	Time Delay Relay
2	A24258-002	Potentiometer
3	02-1810-00	Knob

NDE754 SERVICE PARTS

Ice Chute and Dispensing

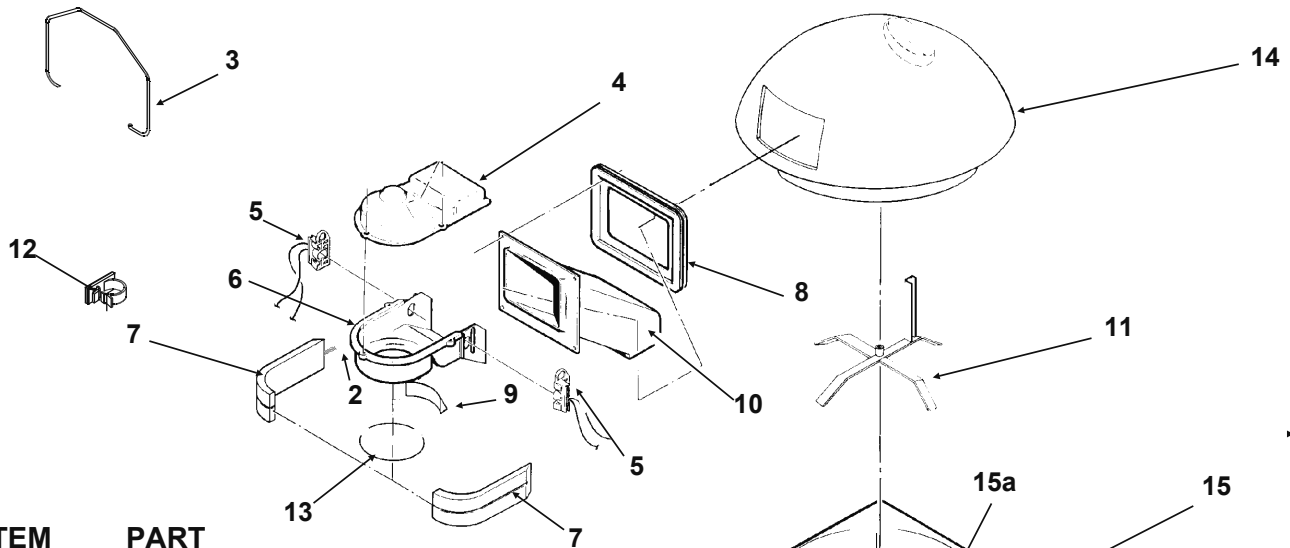

ITEM NUMBER	PART NUMBER	DESCRIPTION
1	02-3233-01	Door gasket
2	A35419-020	Strap kit
3	A34969-001	Bail Clamp
4	02-2957-02	Ice Chute Cover
5	A37711-021	Ice Level Sensors (set)
6	02-2958-01	Ice Chute Body
7	A32963-001	Insulation half
8	13-0875-01	Grommet
9	A33102-001	Insulation
10	02-2973-02	Chute extension
11	02-3116-01	Agitator
12	02-3268-01	Drain hose clip
13	13-0617-54	O-ring
14	A34957-001	Bin cover
15	A34016-001	Storage bin
15a	A32735-001	Ice Rod
16	12-2862-01	Door solenoid
17	A32698-001	Seal
18	A32693-001	Foam seal (round)
19	A32692-001	Foam seal
20	03-1418-15	Screw
21	A34017-001	Plate
22	12-2368-01	Gearmotor Assy
	A32672-001	Heater for gearmotor
23	A32685-001	Linkage pins, med.
24	03-0396-01	Cotter pin
25	02-3206-01	Solenoid linkage
26	A32690-001	Door spring
27	A32687-001	Linkage pins, small
28	A32787-001	Door
29	A32684-001	Long Axle
30	03-1539-09	"C" Clip
31	03-1407-02	Washer

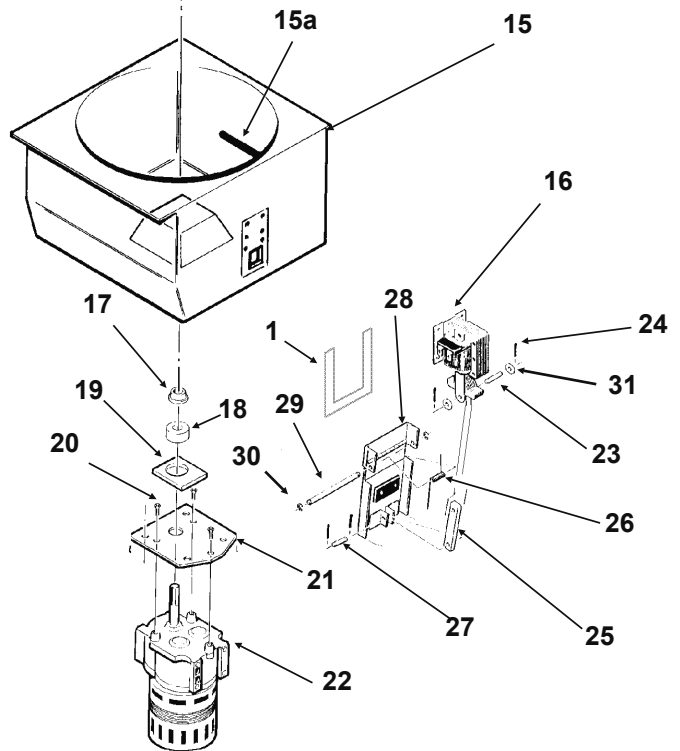

NDE754 SERVICE PARTS

Air Cooled Refrigeration

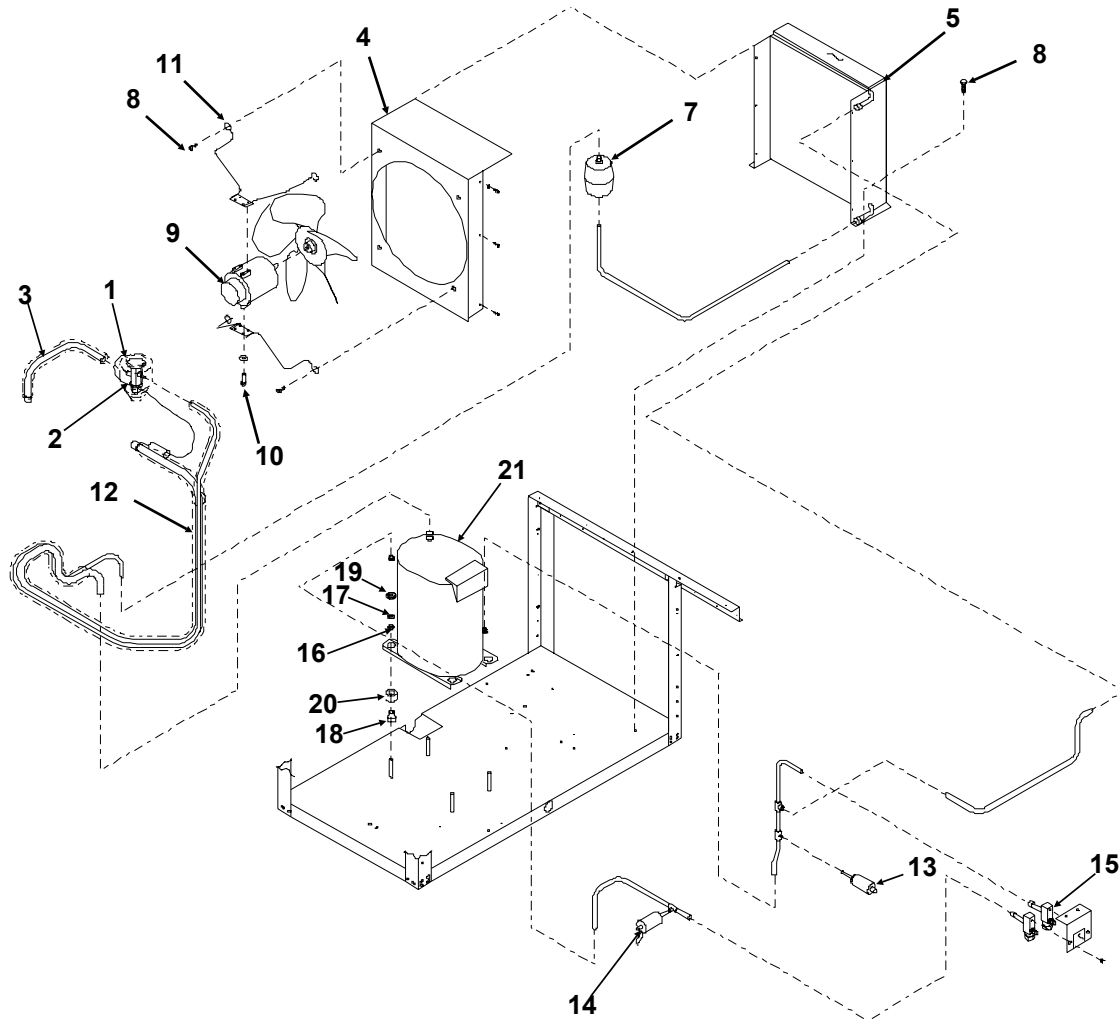

ITEM NUMBER	PART NUMBER	DESCRIPTION	ITEM NUMBER	PART NUMBER	DESCRIPTION
1	A32961-020	Insulation kit, 3 piece	12	A35949-001	Suction line
2	11-0488-21	Thermo expansion valve	13	11-0501-22	Hi press. cut out
3	ref only	Evaporator inlet	14	11-0502-21	Low press. cut out
4	A35911-001	Fan shroud	15	16-0832-20	Access Valve
5	18-8732-01	Condenser		16-0832-02	Stem cap
6	18-3732-01	Fan blade		16-0832-03	Core cap
7	02-3319-02	Dryer	16	03-1407-07	Washer
8	03-1645-01	Screw	17	03-1410-04	Lockwasher
9	18-5105-11	Fan Motor	18	18-2200-28	Grommet
10	03-1531-08	Screw	19	03-1406-10	Hex nut
11	02-3333-01	Fan motor bracket	20	18-2200-27	Metal sleeve
			21	18-8721-21	Compressor
				18-8711-50	Overload for compressor

NDE754 SERVICE PARTS

Water Cooled Refrigeration

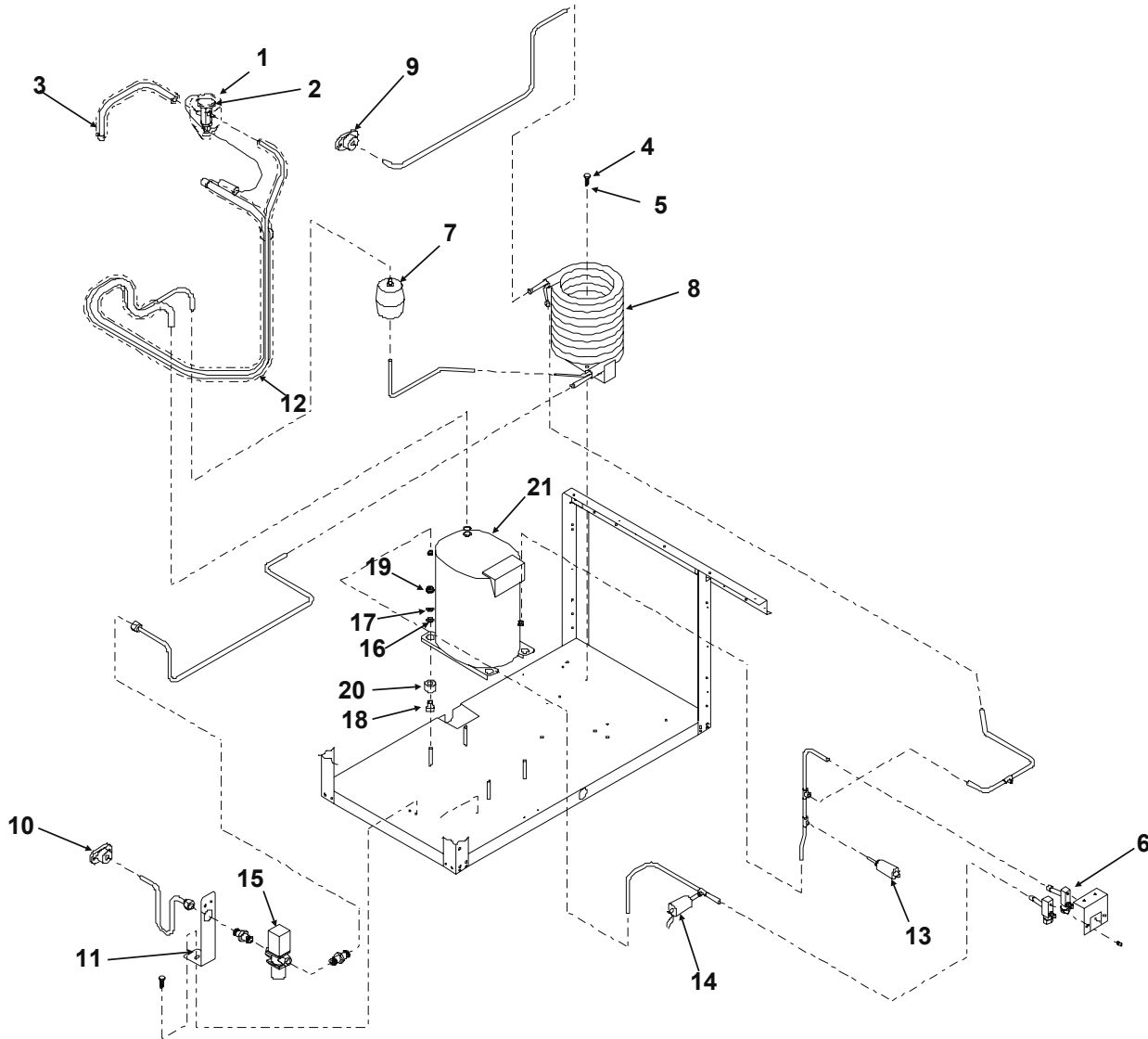

ITEM NUMBER	PART NUMBER	DESCRIPTION	ITEM NUMBER	PART NUMBER	DESCRIPTION
1	A32961-020	Insulation kit, 3 piece	12	A35949-001	Suction line
2	11-0488-21	Thermo expansion valve	13	11-0501-22	Hi press. cut out
3	no number	Evap inlet tube	14	11-0502-21	Low press. cut out
4	03-1645-01	Screw	15	11-0478-01	Water reg. valve
5	03-1407-05	Washer	16	03-1407-07	Washer
6	16-0832-20	Access Valve	17	03-1410-04	Lockwasher
	16-0832-02	Stem cap	18	18-2200-28	Grommet
	16-0832-03	Core cap	19	03-1406-10	Hex nut
7	02-3319-02	Dryer	20	18-2200-27	Metal sleeve
8	18-3306-25	Condenser	21	18-8721-21	Compressor
9	A31828-002	Adaptor flange		18-8711-50	Overload for compressor
10	A31828-001	Adaptor flange			
11	A33990-015	Bracket			

NDE754 SERVICE PARTS

Water System

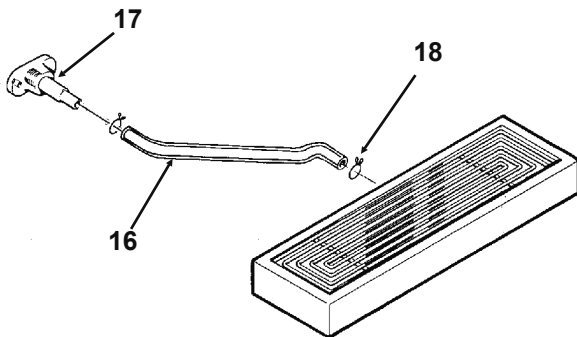
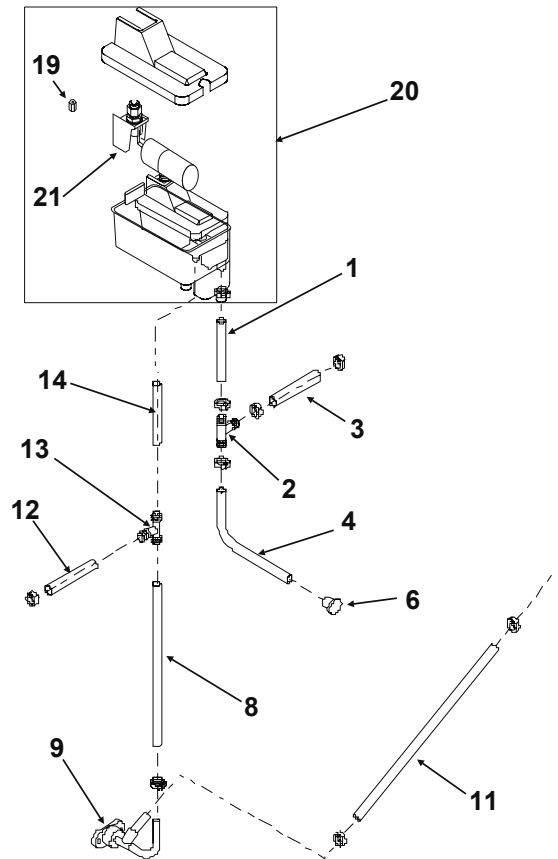
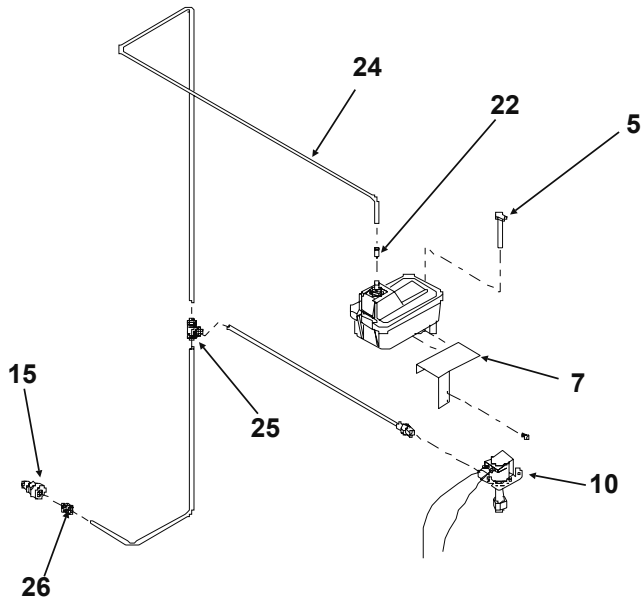

ITEM NUMBER	PART NUMBER	DESCRIPTION
1	13-0674-06	Tubing, 11" req.
2	02-2814-07	Hose clamp
3	05-0501-01	Evap. inlet tubing (preformed)
4	13-0674-06	Tubing, 11" req.
5	12-2760-21	Water sensor
6	13-0840-01	Rubber plug
7	A35952-001	Reservoir bracket
8	13-0079-03	Drain tubing, 25" req.
9	A31757-001	Drain assy
10	12-1646-05	Inlet water valve
11	13-0674-06	Drain tubing 24" req.
12	13-0079-03	Drain tubing 4" req.
13	16-0670-02	Tee
14	13-0079-03	Drain tubing 24" req.
15	16-0835-01	Water inlet fitting
16	13-0674-07	Sink drain tube 33" req.
17	A31757-002	Drain casting
18	02-2814-10	Hose clamp
19	02-3266-03	Plunger/seat
20	02-3266-21	Float valve
21	02-3266-20	Reservoir Assy, includes 19, 20
22	16-0871-01	Insert

NDE754 SERVICE PARTS

Evaporator

ITEM NUMBER	PART NUMBER	DESCRIPTION
1	03-1420-03	Cap Screw
	03-1417-13	Lockwasher
2	A33194-020	Evaporator
3	A32962-001	Insulation half
4	A32962-002	Insulation half
5	02-0929-23	Water seal
6	A32777-001	Retaining ring for seal
7	02-3837-01	Drip pan

ITEM NUMBER	PART NUMBER	DESCRIPTION
8	13-0704-00	Gasket
9	13-0868-01	Water shed
10	02-2977-01	Lip Seal
11	13-0617-54	O-Ring
12	A32900-020	Breaker (incl. 10,14,22)
13	03-1544-08	Soc. head screw
14	13-0617-45	O-ring
15	03-1405-52	Hex cap screw
16	02-3001-01	Ice sweep
17	13-0871-01	Water shed
18	02-2978-01	Lip seal
19	02-3128-20	Breaker cover
20	13-0617-52	O-ring
21	08-0660-01	Auger stud
22	A34559-020	Bearing
23	A38071-021	Auger

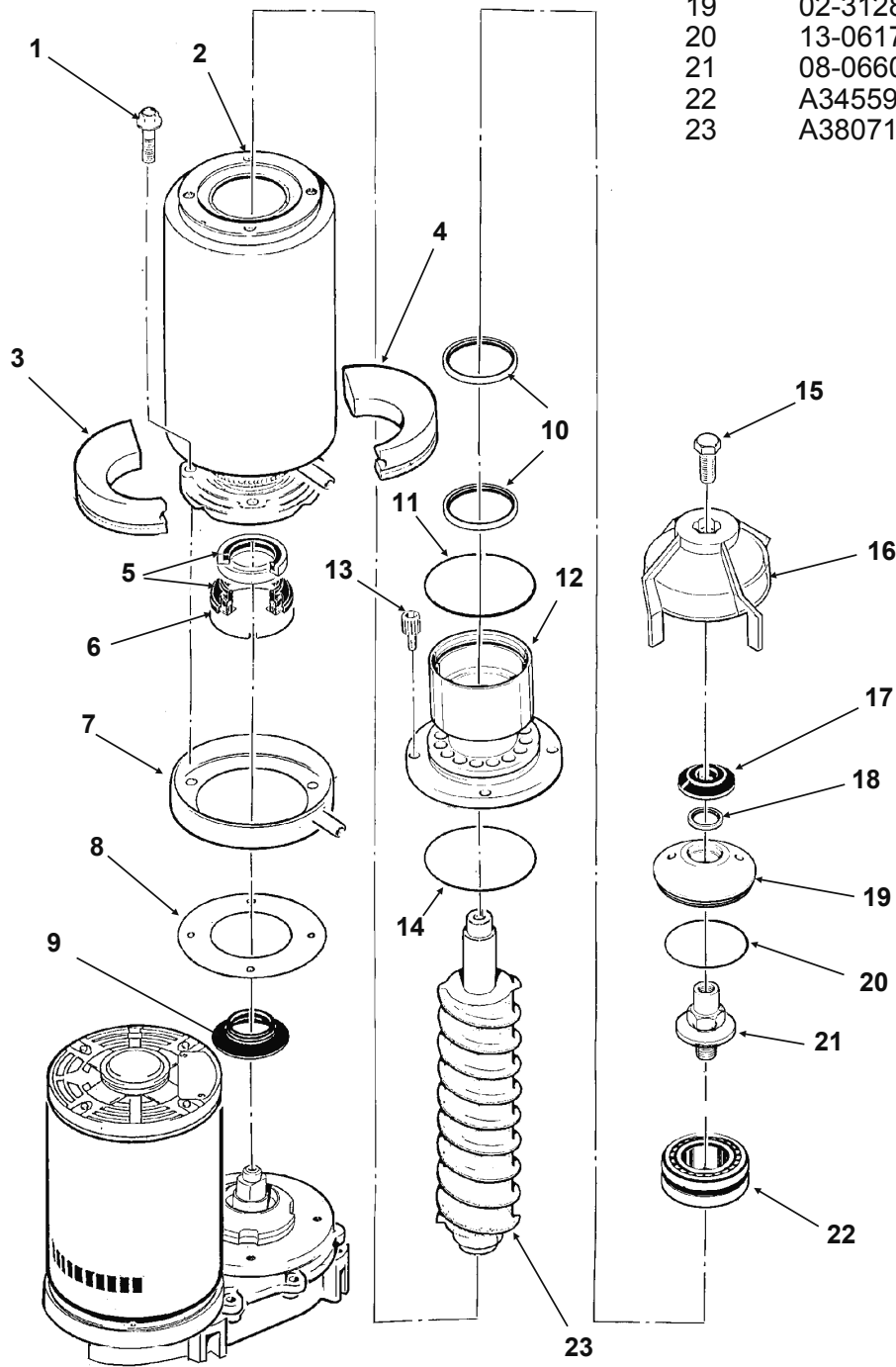

NDE754 SERVICE PARTS

Gearmotor

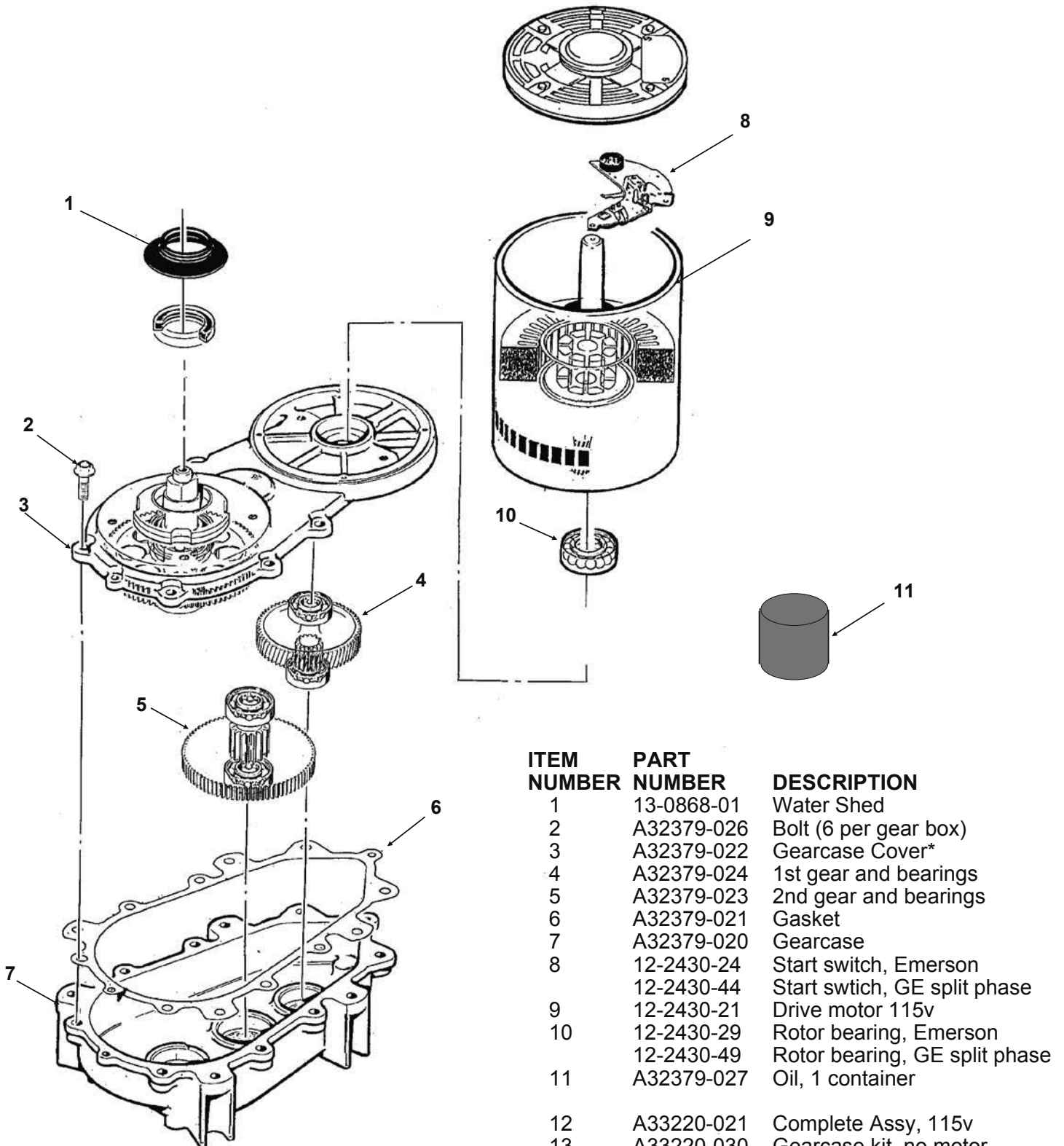

ITEM NUMBER	PART NUMBER	DESCRIPTION
1	13-0868-01	Water Shed
2	A32379-026	Bolt (6 per gear box)
3	A32379-022	Gearcase Cover*
4	A32379-024	1st gear and bearings
5	A32379-023	2nd gear and bearings
6	A32379-021	Gasket
7	A32379-020	Gearcase
8	12-2430-24	Start switch, Emerson
	12-2430-44	Start switch, GE split phase
9	12-2430-21	Drive motor 115v
10	12-2430-29	Rotor bearing, Emerson
	12-2430-49	Rotor bearing, GE split phase
11	A32379-027	Oil, 1 container
12	A33220-021	Complete Assy, 115v
13	A33220-030	Gearcase kit, no motor

* Note: Gearcase cover includes cover, output shaft, key, output gear, bearings and seal.

NDE754 SERVICE PARTS

Control Box

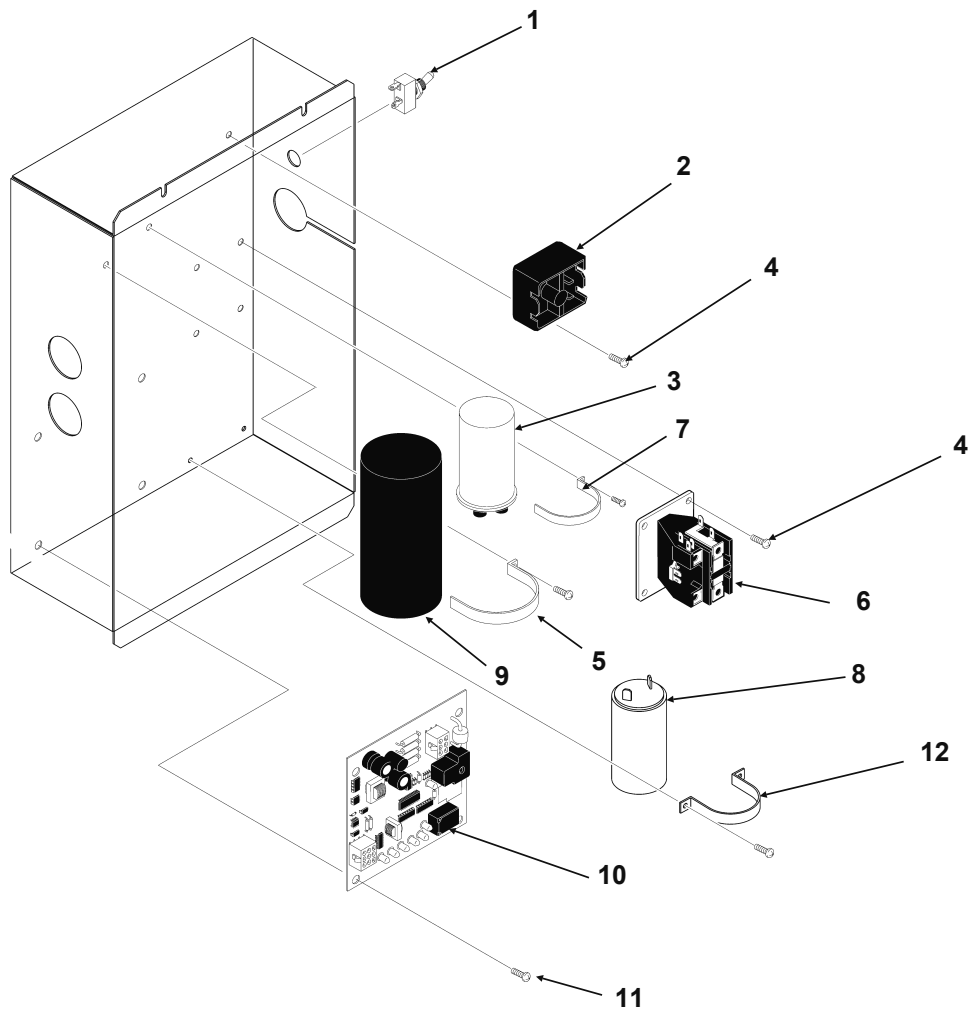

ITEM NUMBER	PART NUMBER	DESCRIPTION
1	12-0426-02	Mode switch
2	18-1903-50	Potential Relay
3	18-1902-45	Run capacitor for compressor
4	03-1531-01	Screw
5	A35971-001	Capacitor bracket
6	12-2469-03	Contactor 115v
7	A35971-002	Capacitor bracket
8	18-3701-01	Run capacitor-bin drive motor
9	18-1901-03	Start capacitor
10	12-2744-21	Circuit board
11	A33219-001	Standoff
12	A35971-001	Capacitor bracket
NOT ILLUSTRATED		
13	A34528-015	Control box cover
14	12-2360-01	Time delay relay (portion control)
15	A24258-002	Potentiometer

NDE754 SERVICE PARTS

Wiring Diagram

17-2861-01

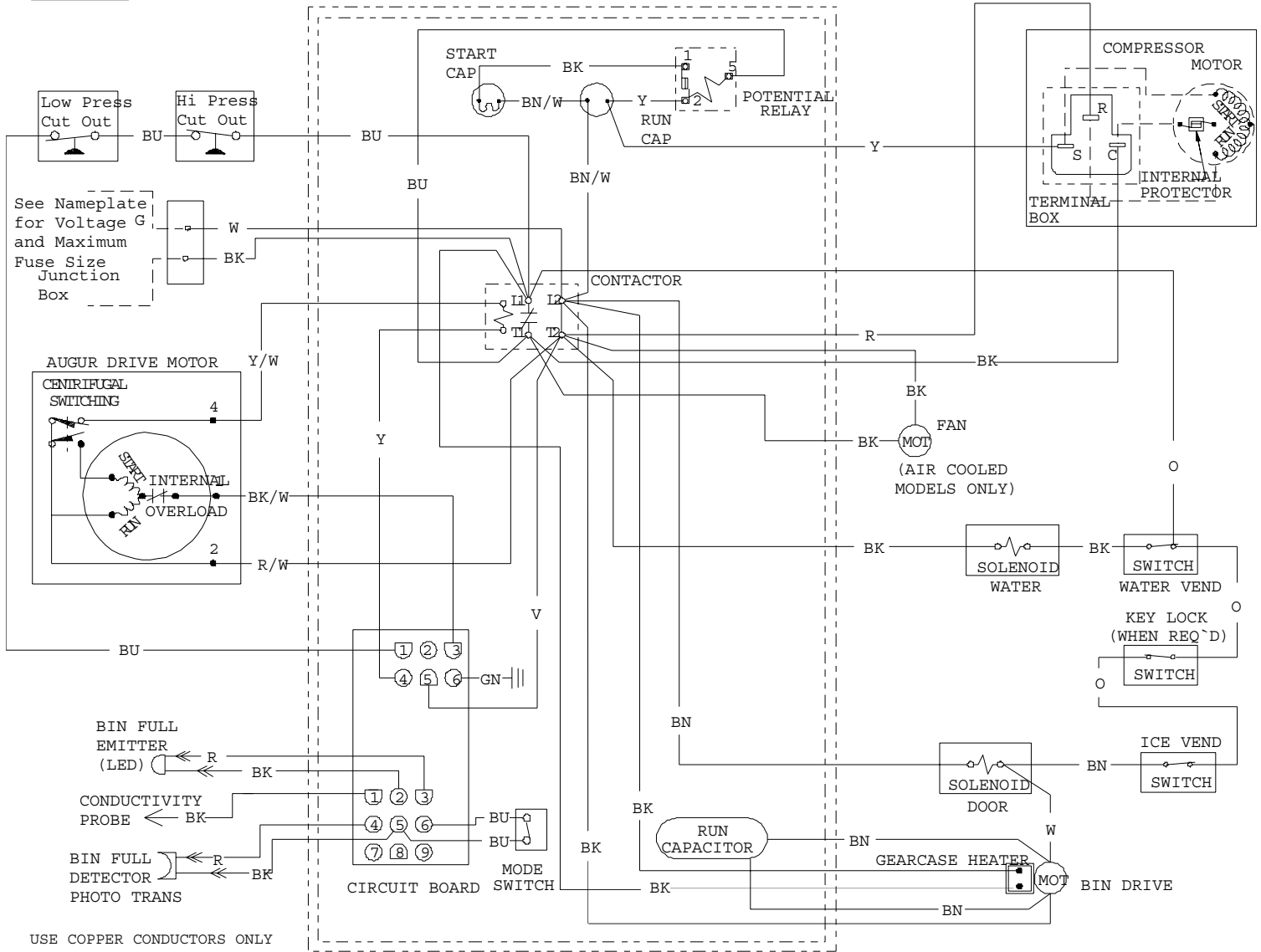

USE COPPER CONDUCTORS ONLY

THIS UNIT MUST BE GROUNDED

CONTROL BOX

NDE754 SERVICE PARTS Schematic Diagram

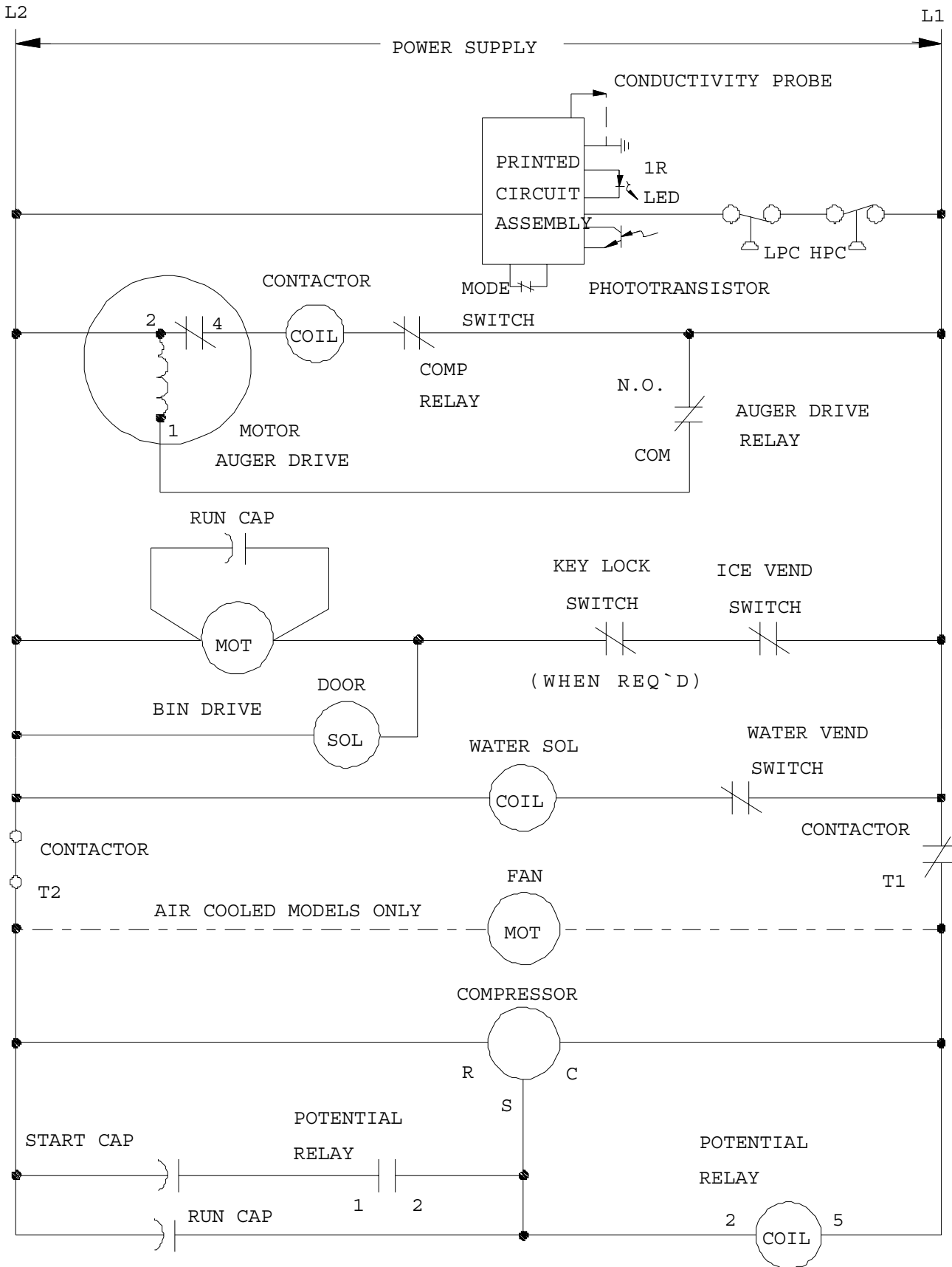

ALL CONTROLS SHOWN IN NORMAL ICE MAKING MODE

WITH ALL DISPENSING SYSTEMS IN OPERATION.