

# NM1250 SERVICE PARTS

This section contains the parts lists and illustrations for the NM1250.

When ordering parts of assemblies, to avoid costly delays and errors in shipment, give the complete description as shown in the list.

## Table of Contents

Panels.....	page 2
Refrigeration .....	page 3
Evaporator .....	page 5
Gearbox .....	page 6
Control Box .....	page 7
Reservoir and Drains .....	page 8
Wiring Diagrams .....	page 9

# NM1250 SERVICE PARTS

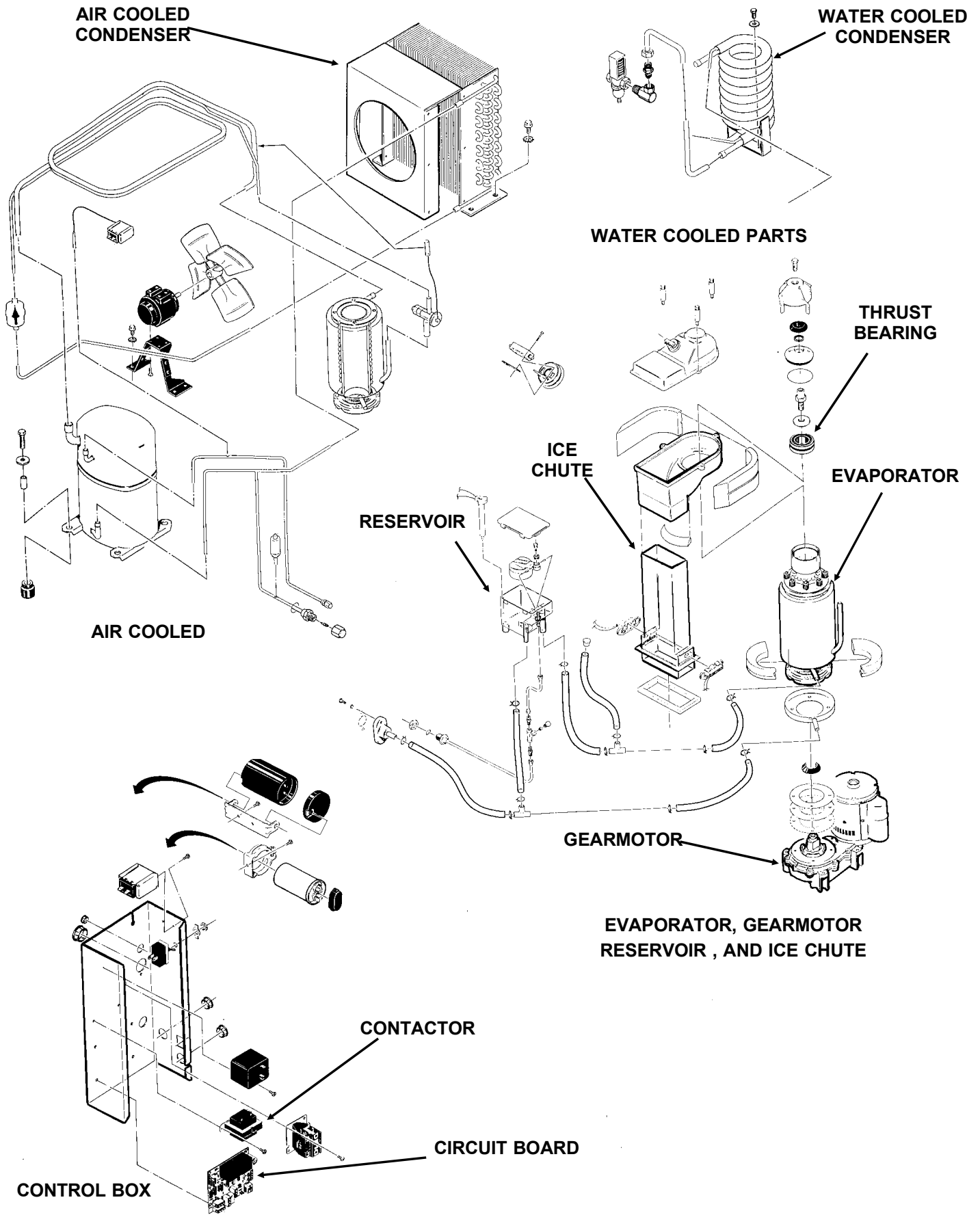

# NM1250 SERVICE PARTS PANELS

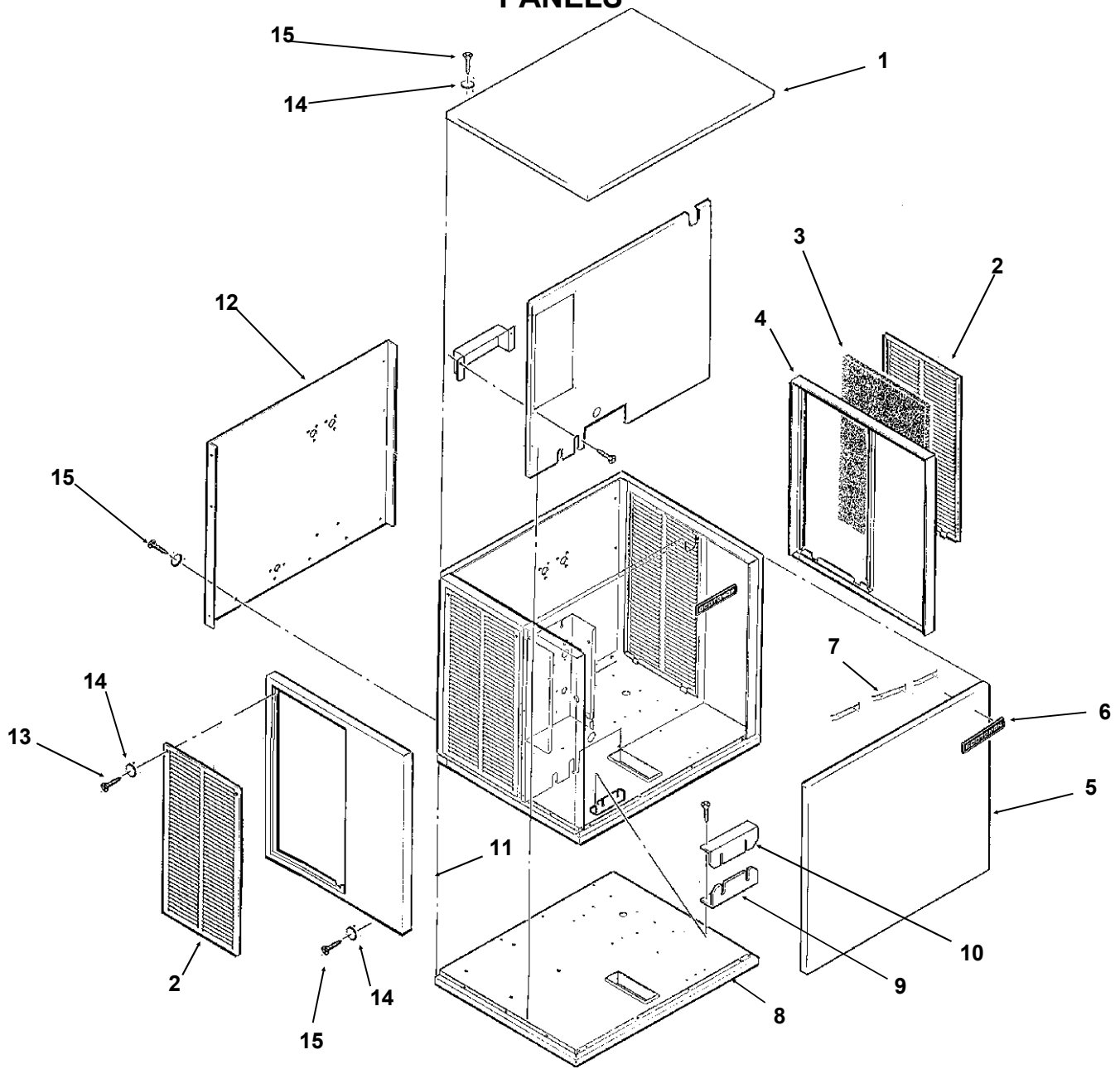

ITEM NUMBER	PART NUMBER	DESCRIPTION	ITEM NUMBER	PART NUMBER	DESCRIPTION
1.	A32159-001	Top Panel Painted	8.	A32542-001	Base Assembly
	A32159-002	Top Panel Stainless	9.	A31462-001	Tube Bracket
2.	A32161-001	Service Panel Paint	10.	A31461-001	Tube Bracket
	A32161-002	Service Panel S.S.	11.	A32163-001	Left End Panel Pt.
3.	A32975-001	Filter		A32163-002	Left End Panel S.S.
4.	A32162-001	Right End Panel Pt.	12.	A32202-001	Back Panel
	A32162-002	Right End Panel S.S.	13.	03-1404-12	Screw
5.	A32160-001	Front Panel Painted	14.	03-1417-03	Washer
	A32160-002	Front Panel S.S.	15.	03-1531-01	Screw
6.	15-0711-01	Emblem			
7.	03-0271-00	Clip For Emblem (3)			

# NM1250 SERVICE PARTS AIR COOLED REFRIGERATION

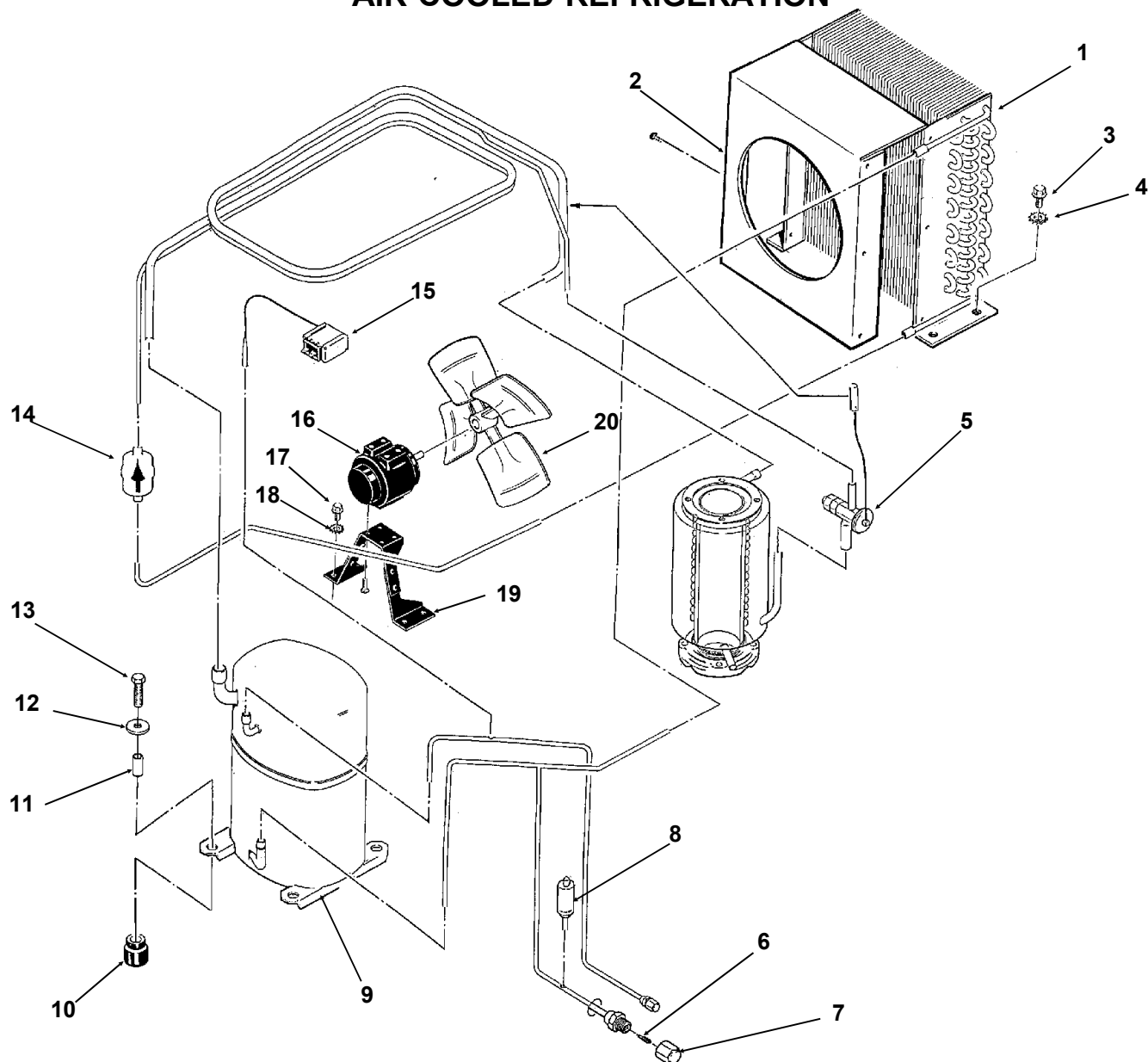

ITEM NUMBER	PART NUMBER	DESCRIPTION	ITEM NUMBER	PART NUMBER	DESCRIPTION
1.	18-3709-01	Air Cooled Condens.	10.	18-6800-01	Grommet
2.	A32170-001	Shroud	11.	18-2300-26	Sleeve
3.	03-1645-01	Bolt	12.	03-1407-07	Washer
4.	03-1417-09	Washer	13.	03-1405-20	Bolt
5.	16-0780-21	Expansion Valve	14.	02-3319-02	Drier
6.	16-0560-00	Valve Core	15.	11-0447-20	L. P. Control
7.	16-0563-00	Valve Cap	16.	18-5105-02	Fan Motor
8.	11-0446-21	Pressure Control	17.	03-1404-03	Screw
9.	18-5900-02	Compressor 208-230/60/1	18.	03-1417-09	Washer
	18-5900-03	Compressor 208-230/60/3	19.	18-3739-01	Fan Motor Bracket
			20.	18-3732-01	Fan Blade

# NM1250 SERVICE PARTS WATER COOLED REFRIGERATION

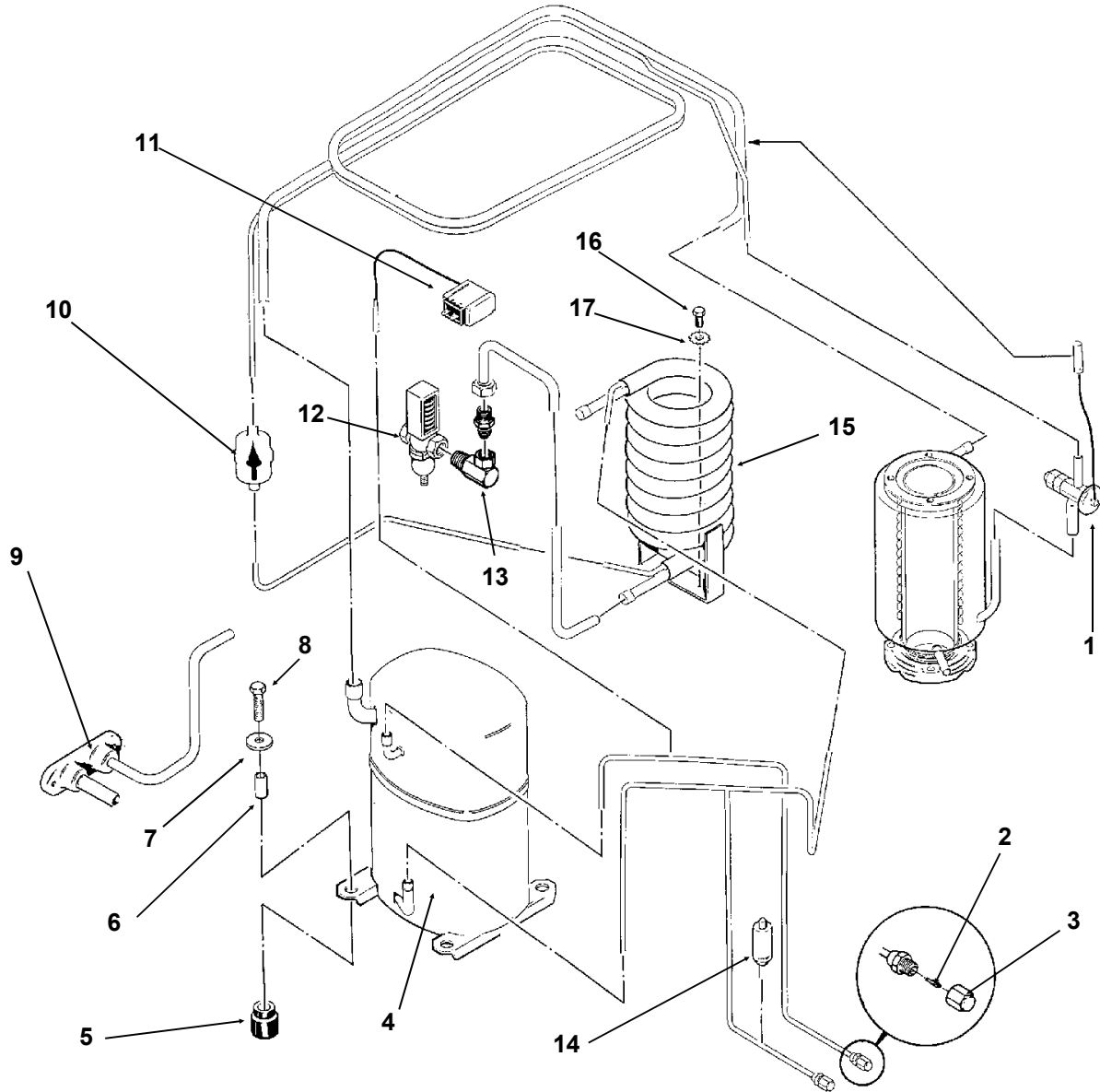

ITEM NUMBER	PART NUMBER	DESCRIPTION	ITEM NUMBER	PART NUMBER	DESCRIPTION
1.	16-0780-21	Expansion Valve	8.	03-1405-20	Bolt
2.	16-0560-00	Valve Core	9.	A32892-001	Drain
3.	16-0563-00	Valve Cap	10.	02-3319-02	Drier
4.	18-5900-03	Compressor	11.	11-0447-20	Lo Press. Control
	18-5900-02	Compressor	12.	11-0424-01	Water Reg. Valve
		208-230/60/3	13.	16-0401-02	Elbow
		208-230/60/1	14.	11-0446-21	Pressure Control
5.	18-6800-01	Grommet	15.	18-6900-25	Water Cooled Condenser
6.	18-2300-26	Sleeve	16.	03-1645-01	Screw
7.	03-1407-07	Washer	17.	03-1417-09	Washer

# NM1250 SERVICE PARTS EVAPORATOR

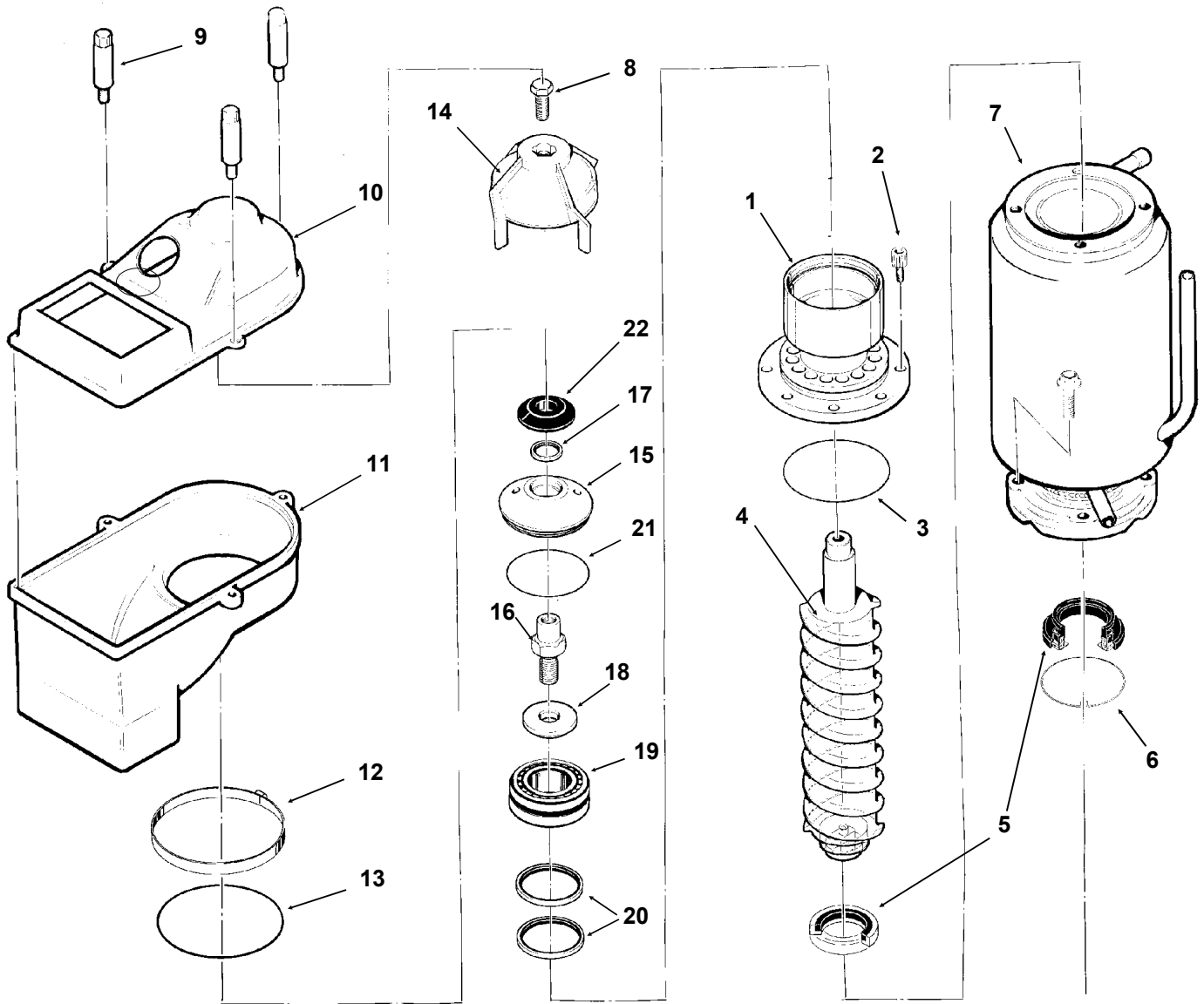

ITEM NUMBER	PART NUMBER	DESCRIPTION	ITEM NUMBER	PART NUMBER	DESCRIPTION
1.	A32900-020	Breaker Includes Items 19 & 20	10.	02-2930-01	Ice Chute Cover
2.	03-1544-08	Soc. head Screw	11.	02-2926-01	Ice Chute Body
3.	13-0617-45	O-ring	12.	A32905-001	Clamp
4.	A38071-022	Auger	13.	13-0617-52	O-ring
5.	02-0929-23	Water Seal	14.	02-3001-01	Ice Sweep
6.	A32777-001	Ring, Water Seal	15.	02-3128-20	Breaker Cover
7.	A32890-020	Evaporator	16.	08-0660-01	Auger Stud
8.	03-1405-52	Hex Cap Screw	17.	02-2978-01	Lip Seal
9.	02-2933-01	Hex stud	18.	part of time 16	Thrust Washer
			19.	A34559-020	Bearing
			20.	02-2977-01	Lip Seal
			21.	13-0617-54	O-Ring
			22.	13-0871-01	Water Shed

**Note:** Evaporator is not available with internal parts. The auger and water seal must be ordered separately.

# NM1250 SERVICE PARTS CONTROL BOX

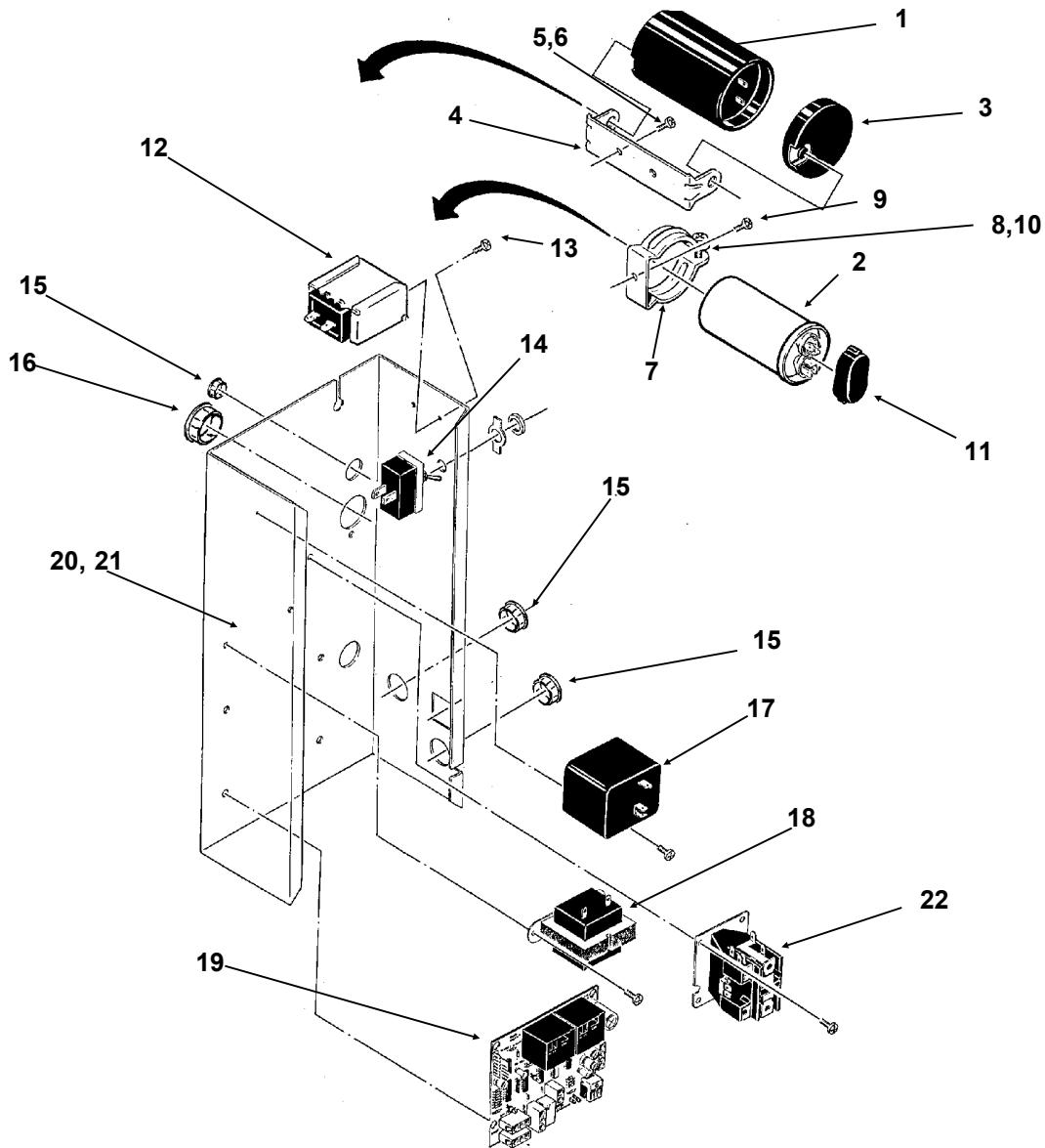

ITEM NUMBER	PART NUMBER	DESCRIPTION	ITEM NUMBER	PART NUMBER	DESCRIPTION
1.	18-1901-48	Start Capacitor	15.	12-1213-10	Snap Bushing
2.	18-1902-53	Run Capacitor	16.	12-1213-11	Snap Bushing
3.	18-4300-50	Start Capacitor Cap	17.	18-1903-46	Relay
4.	18-2200-39	Start Cap. Bracket	18.	12-2285-22	Transformer
5.	03-1638-04	Screw	19.	A37750-021	Circuit Board
6.	03-1417-15	Lockwasher	20.	No Number	Control Box
7.	A32872-001	Run Cap. Bracket	21.	A32896-001	Cont. Box Cover
8.	03-1652-02	Bolt	22.	12-2469-02	1 Phase Contactor
9.	03-1638-03	Screw		12-0739-02	3 Phase Contactor
10.	03-0255-04	Wing Nut	NOT ILLUSTRATED:		
11.	13-0666-00	Terminal Cover	23.	12-2337-02	3 Pin Plug Assy (safety circuit to circuit board)
12.	11-0447-20	Low Press. Control	24.	12-2340-01	4 Pin Plug Assy (transformer to circuit board)
13.	03-1403-02	Screw			
14.	12-0426-01	Master Switch			

# NM1250 SERVICE PARTS GEARMOTOR

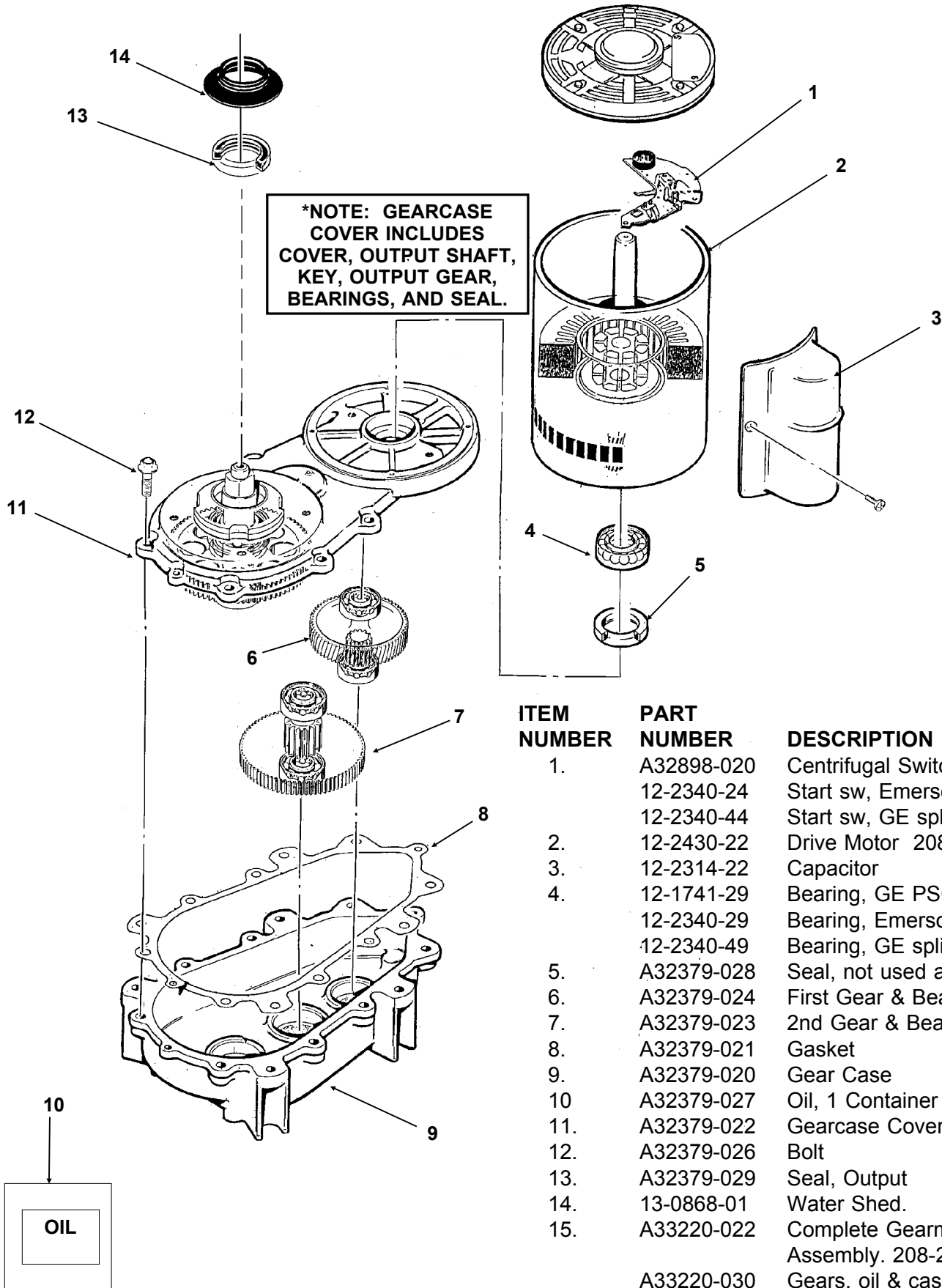

ITEM NUMBER	PART NUMBER	DESCRIPTION
1.	A32898-020	Centrifugal Switch, GE PSC
	12-2340-24	Start sw, Emerson
	12-2340-44	Start sw, GE split phase
2.	12-2430-22	Drive Motor 208-230 v
3.	12-2314-22	Capacitor
4.	12-1741-29	Bearing, GE PSC
	12-2340-29	Bearing, Emerson
	12-2340-49	Bearing, GE split phase
5.	A32379-028	Seal, not used after 2/2000
6.	A32379-024	First Gear & Bearing
7.	A32379-023	2nd Gear & Bearing
8.	A32379-021	Gasket
9.	A32379-020	Gear Case
10	A32379-027	Oil, 1 Container
11.	A32379-022	Gearcase Cover*
12.	A32379-026	Bolt
13.	A32379-029	Seal, Output
14.	13-0868-01	Water Shed.
15.	A33220-022	Complete Gearmotor Assembly. 208-230 v.
	A33220-030	Gears, oil & cases. No motor



# NM1250 SERVICE PARTS

## RESERVOIR, DRAINS, ICE CHUTE, ICE LEVEL SENSORS

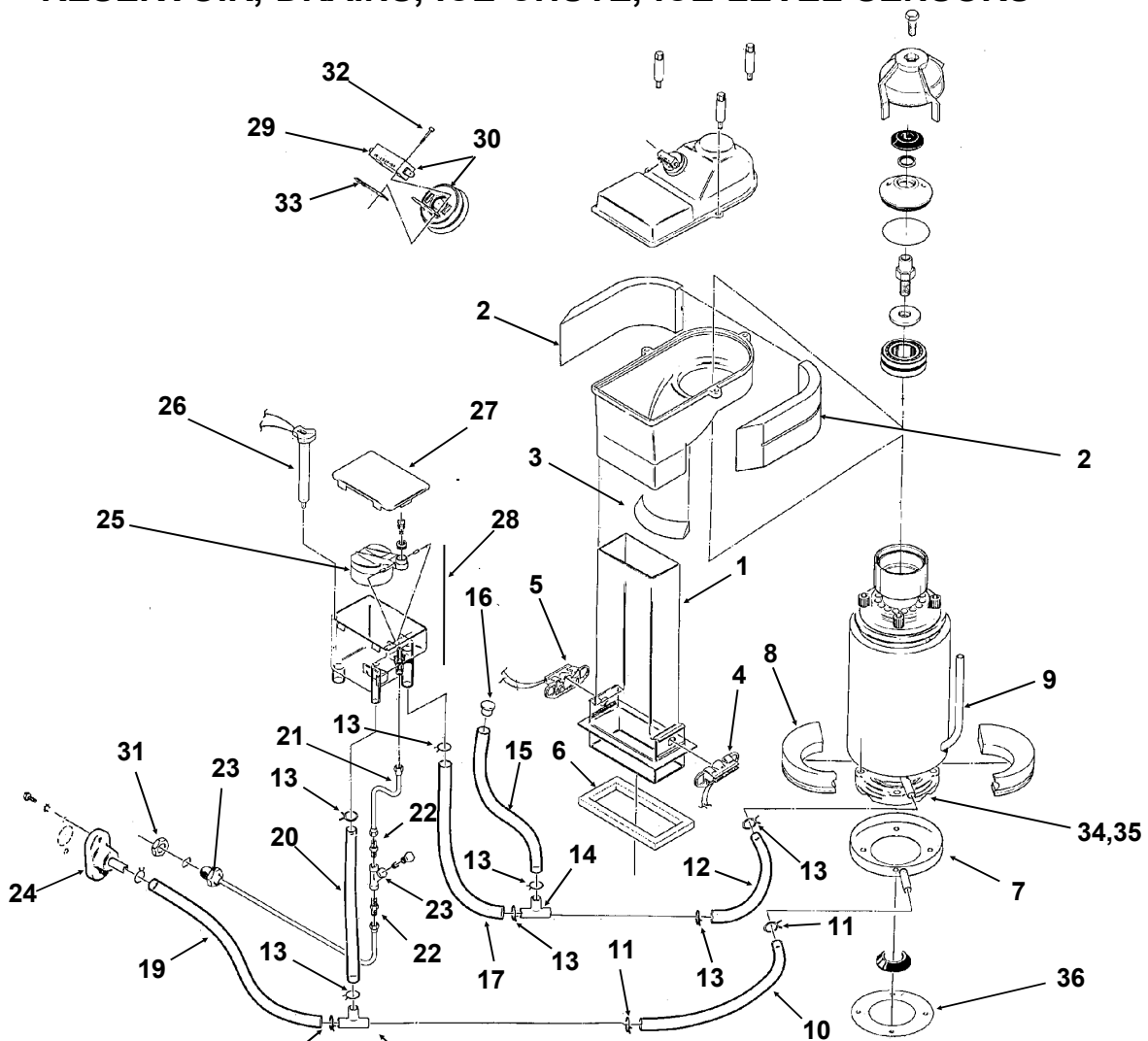

ITEM NUMBER	PART NUMBER	DESCRIPTION	ITEM NUMBER	PART NUMBER	DESCRIPTION
1.	02-2929-01	Ice Chute Lower	19.	13-0079-03	Tube, 18" Order By Ft.
2.	A32963-001	Insulation Collar Top	20.	13-0079-03	Tube, 11" Order By Ft.
3.	A33102-001	Insulation Collar Inside	21.	A32748-001	Tube
4.	A33210-001	Rubber Band	22.	16-0791-01	Coupling Union
	A37708-021	LED & Phototransistor Assy. (set - includes item 5)	23.	A32878-001	Inlet Water Tube
5.	no number	same as item 4.	24.	A32282-004	Drain - Air Cooled
6.	A32930-001	Chute Gasket		A32892-001	Drain - Water Cooled
7.	A32050-001	Drip Pan	25.	A32922-020	Float Assy With Pin, Housing Seal, Rubber Seal, Insert & Float.
8.	A32962-001	Insulation Collar Bottom	26.	A33101-021	Thermo Probe
9.	A32962-002	Insulation Collar Bottom	27.	02-2936-01	Reservoir Cover
10.	13-0079-03	Hose 3.3" Order By Ft.	28.	A32929-020	Float And Reservoir Complete
11.	02-0538-00	Hose Clamp	29.	12-2329-01	Switch
12.	A33203-001	Preformed Hose	30.	A32891-020	Switch Housing W/Switch
13.	02-2814-08	Hose Clamp	31.	03-1394-01	Pal Nut
14.	16-0670-01	Tee	32.	03-1403-09	Screw
15.	13-0674-06	Tube, 14" Order By Ft.	33.	03-0886-00	Speed Nut
16.	A33205-001	Plug	34.	03-1405-41	Stud, Evap to GM
17.	13-0674-06	Tube, 9" Order By Ft.	35.	03-1417-13	Lock washer
18.	16-0670-02	Tee	36.	13-0704-00	Drip pan gasket

# NM1250 SERVICE PARTS

AIR AND WATER COOLED, 208-230/60/1

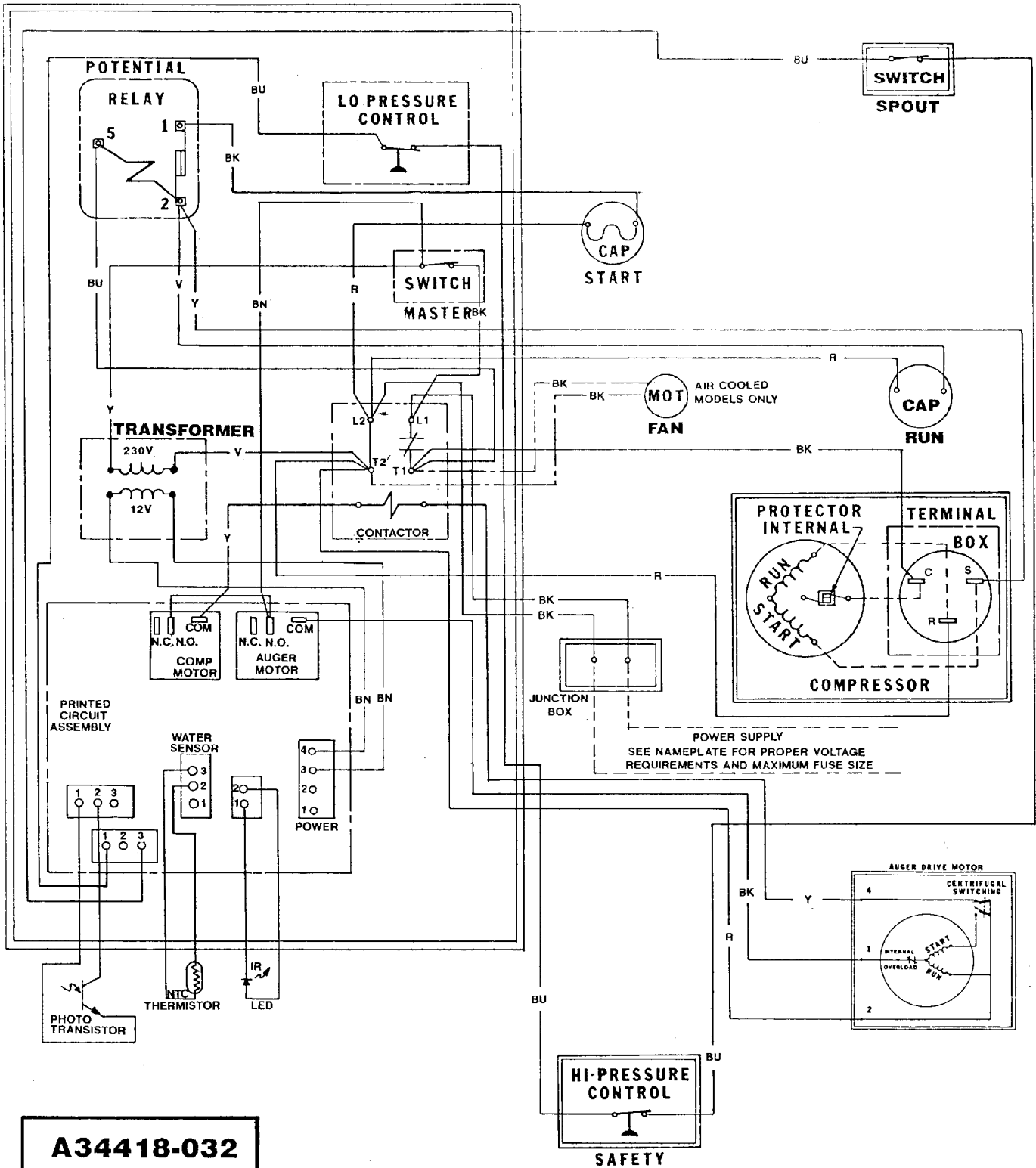

**A34418-032**

# NM1250 SERVICE PARTS

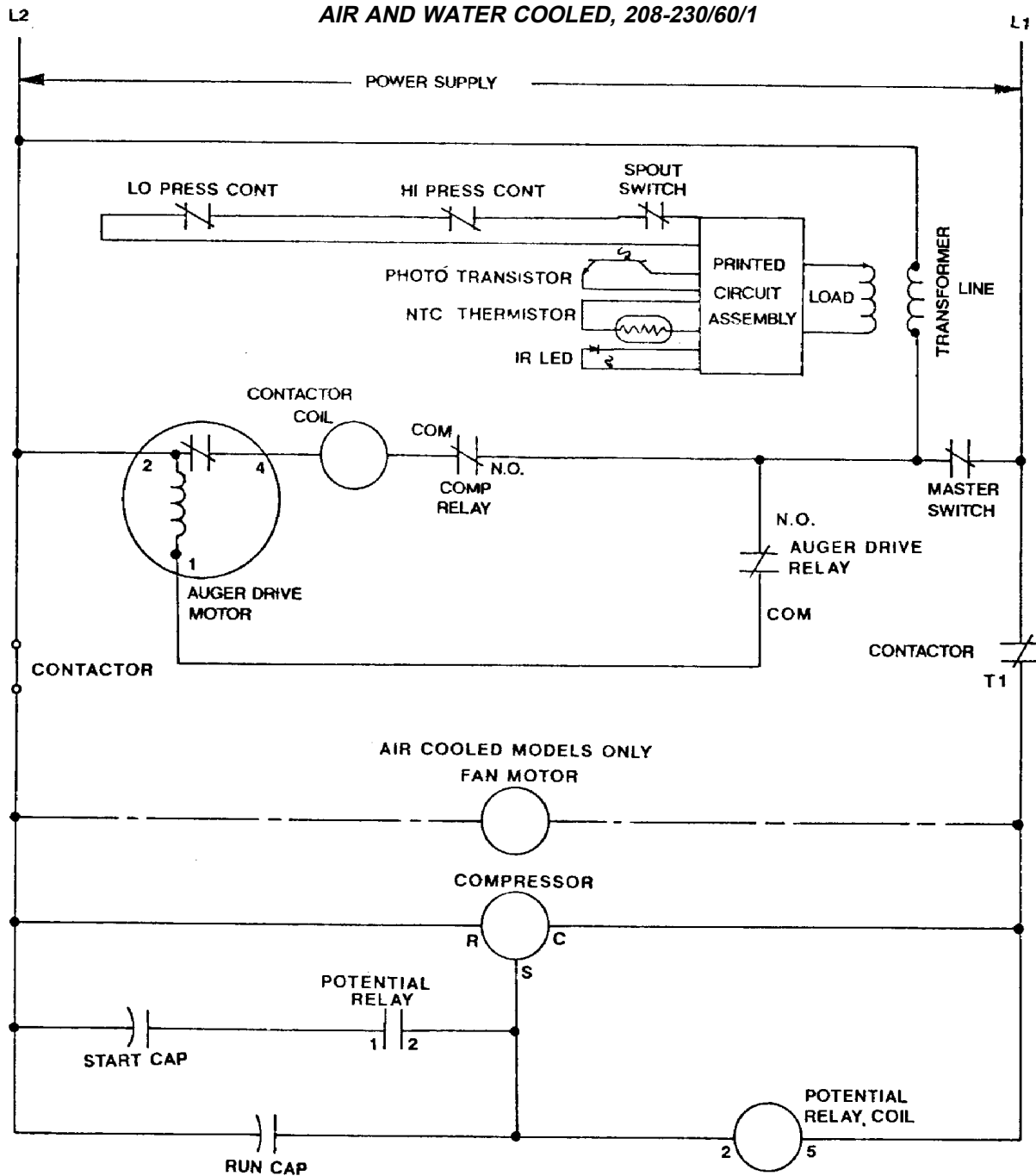

**USE COPPER CONDUCTORS ONLY  
ALL CONTROLS SHOWN IN NORMAL ICEMAKING MODE  
THIS UNIT MUST BE GROUNDED**

# NM1250 SERVICE PARTS

AIR AND WATER COOLED, 208-230/60/3

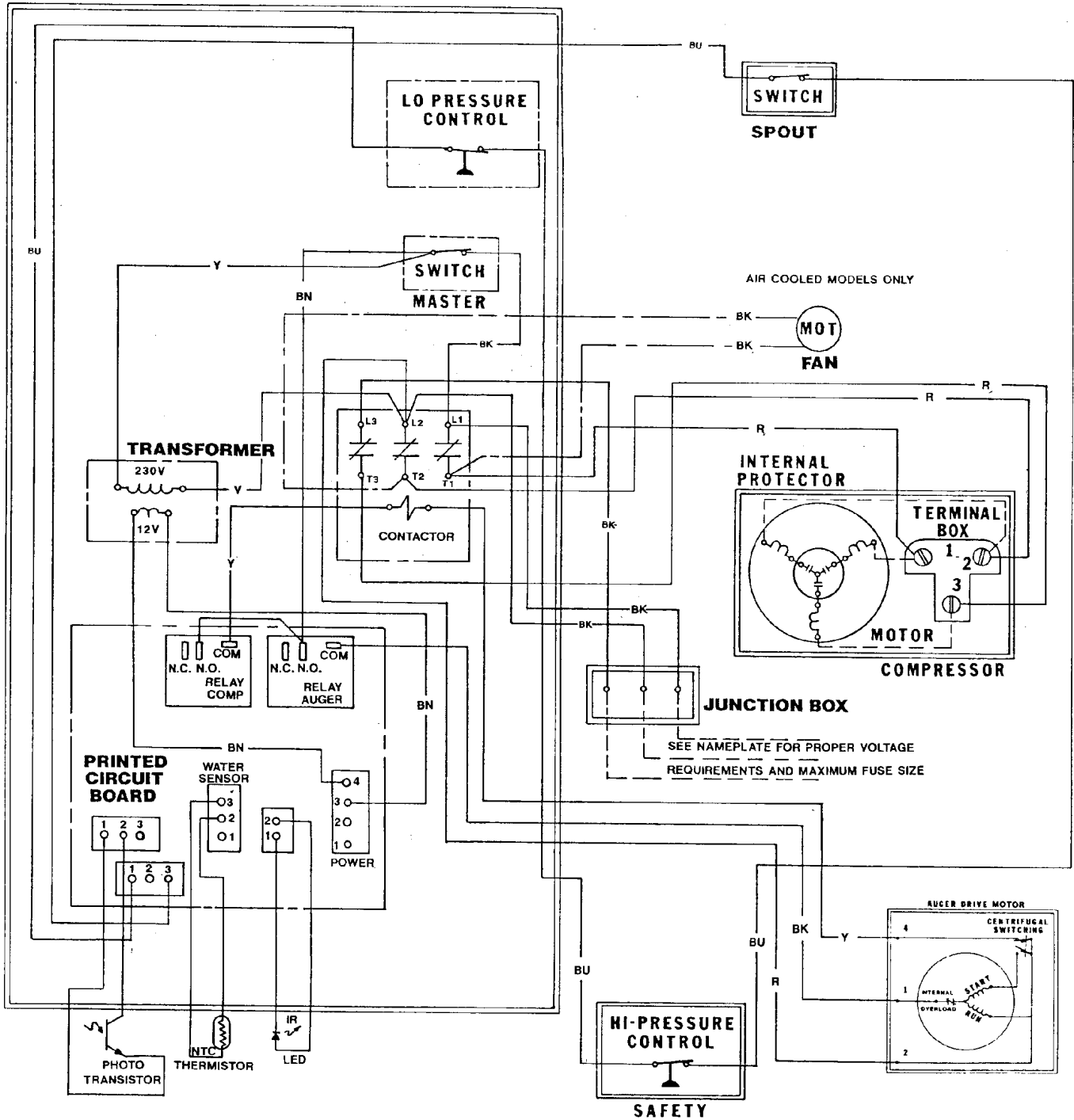

**A34418-003**

# NM1250 SERVICE PARTS

AIR AND WATER COOLED, 208-230/60/3

