

# NM952R SERVICE PARTS

This parts list contains the service parts and wiring diagrams for this model. Check the model number in question to be sure that it is applicable to this parts list.

## TABLE OF CONTENTS

Cabinet .....	2
Refrigeration .....	3
Water .....	4
Gearmotor.....	5
Evaporator .....	6
Control Box.....	7
Remote Condenser .....	8
Wiring Diagrams.....	9

# NM952R SERVICE PARTS

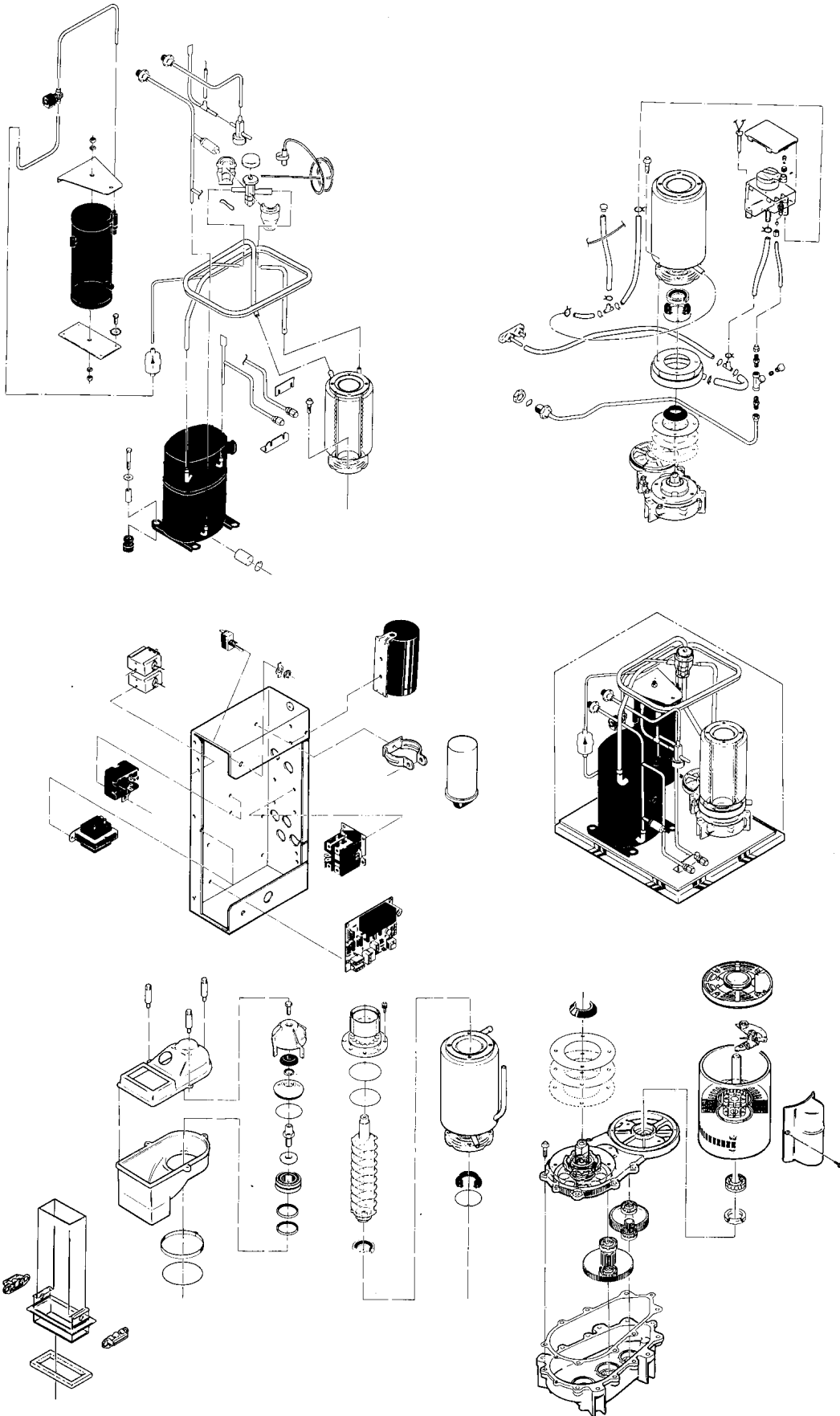

# NM952R SERVICE PARTS

## Cabinet Assembly

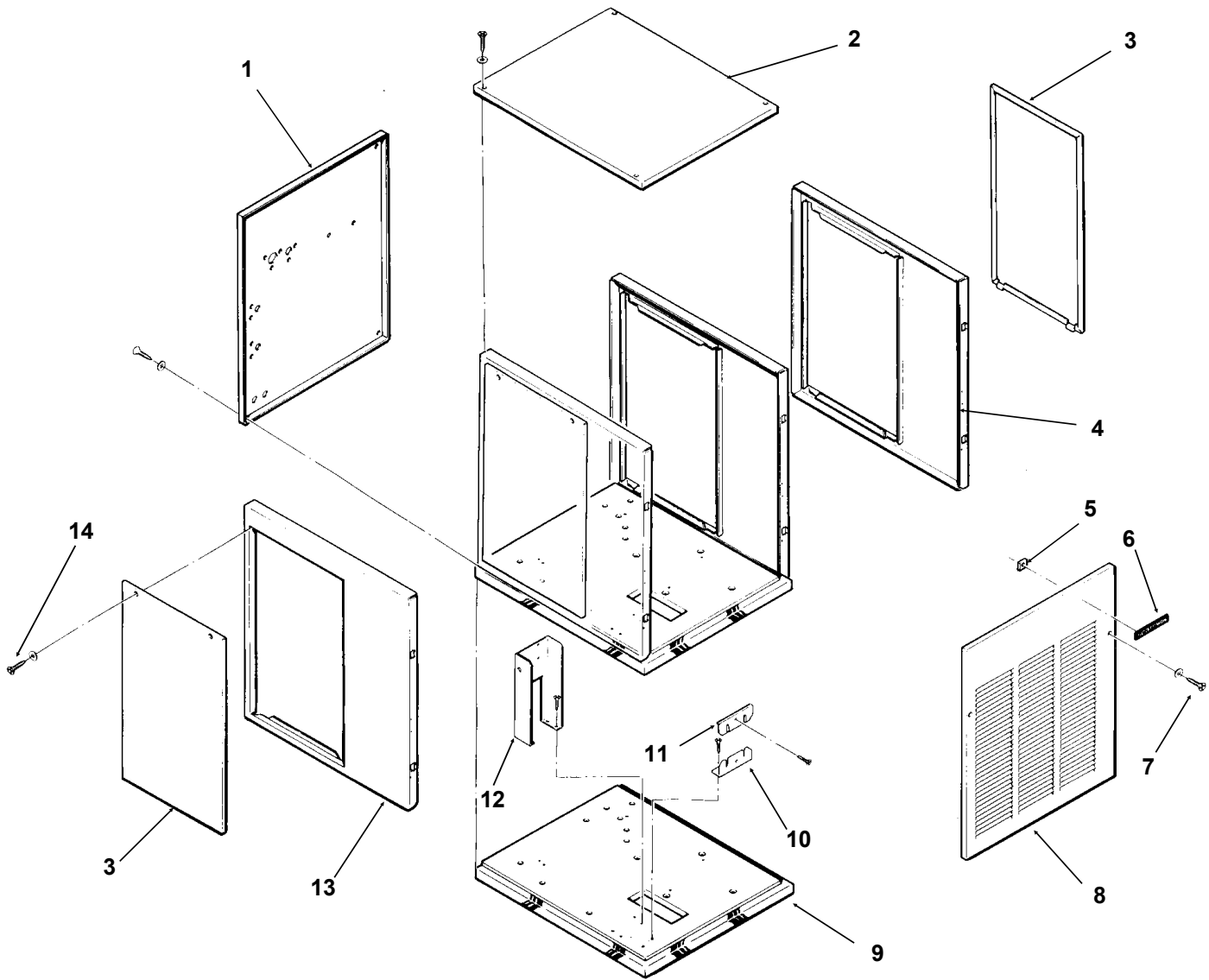

ITEM NUMBER	PART NUMBER	DESCRIPTION	ITEM NUMBER	PART NUMBER	DESCRIPTION
1	A33252-001	Back Panel, Painted	8	A33255-001	Front Panel, Painted
2	A33256-001	Top Panel, Painted		A33255-002	Front Panel, S.S.
	A33256-002	Top Panel, S.S.	9	A34042-001	Base Assembly
3	A34038-001	Service Panel, Painted	10	A31462-001	Tube Bracket
	A34038-002	Service Panel, S.S.	11	A31461-001	Tube Bracket
4	A33292-001	Right Side Panel, Painted	12	A34039-001	Control Box Support
	A33292-002	Right Side Panel, S.S.	13	A32435-001	Left Side Panel, Painted
5	03-0271-00	Speed Clip		A32435-002	Left Side Panel, S.S.
6	15-0711-01	Emblem	14	03-1404-12	Screw
7	03-1419-08	Screw			

# NM952R SERVICE PARTS

## Refrigeration System

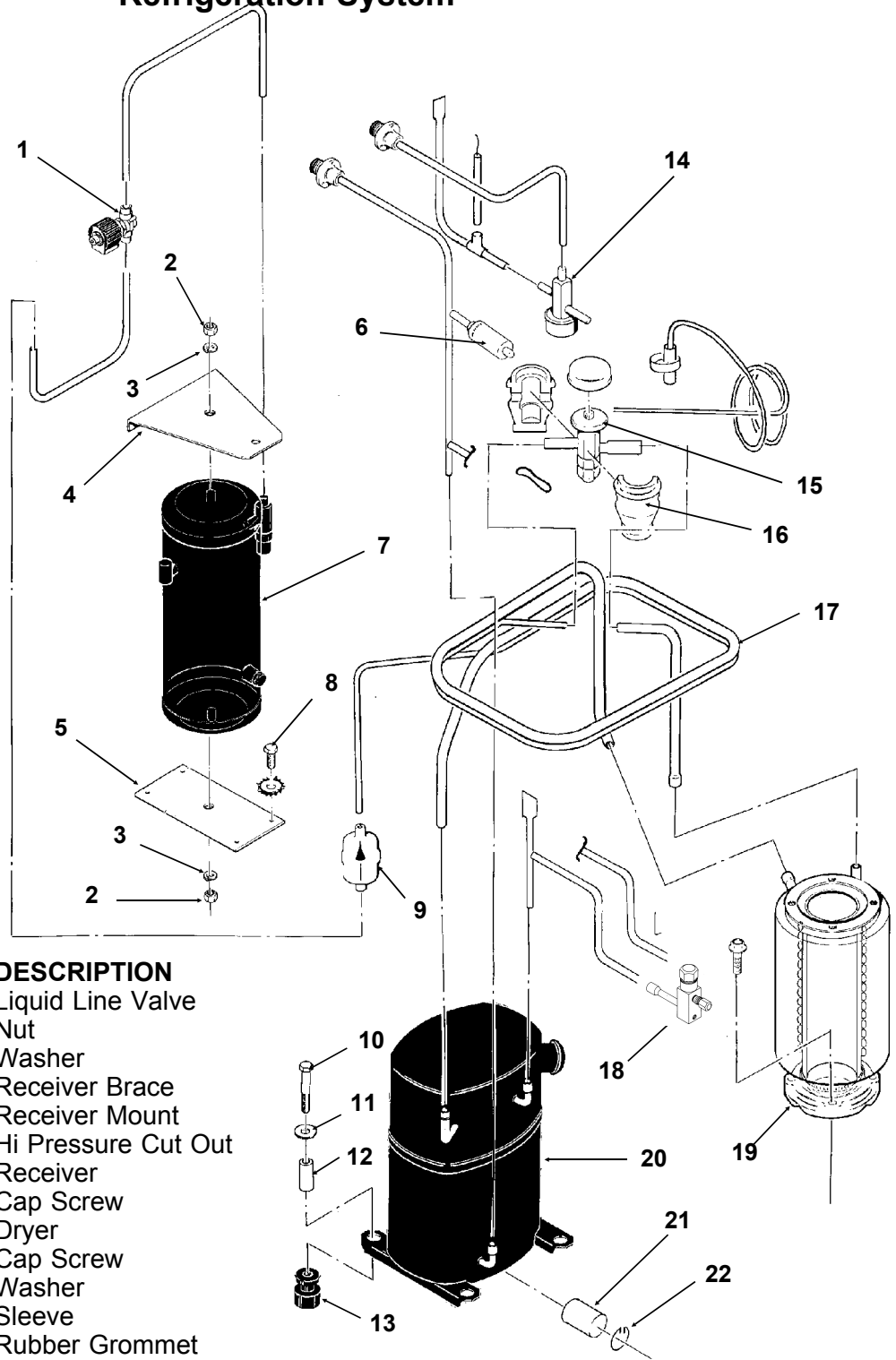

**NOTE: Compressors have internal overloads.**

ITEM NUMBER	PART NUMBER	DESCRIPTION
1	12-2257-21	Liquid Line Valve
2	03-1406-13	Nut
3	03-1410-06	Washer
4	A32968-001	Receiver Brace
5	A31801-002	Receiver Mount
6	11-0446-27	Hi Pressure Cut Out
7	16-0761-01	Receiver
8	03-1645-01	Cap Screw
9	02-3319-02	Dryer
10	03-1405-20	Cap Screw
11	03-1407-07	Washer
12	18-2300-27	Sleeve
13	18-6800-01	Rubber Grommet
14	11-0422-22	Head Pressure Valve
15	11-0477-21	Thermo Expansion Valve
16	A32961-020	Insulation Kit for TXV
17	A35566-001	Suction Line
18a	16-0832-02	Stem cap
18b	16-0832-03	Core cap
19	A32890-020	Evaporator

ITEM NUMBER	PART NUMBER	DESCRIPTION
20	18-8716-23	Compressor 208-230/60/1
21	18-8716-25	Compressor 200-230/60/3
22	18-2308-01	Crankcase Heater
23	18-2309-01	Clip
24	16-0850-03	Male half, 3/8"
	16-0850-01	Male half, 1/2"

# NM952R SERVICE PARTS

## Water System, Water Seal

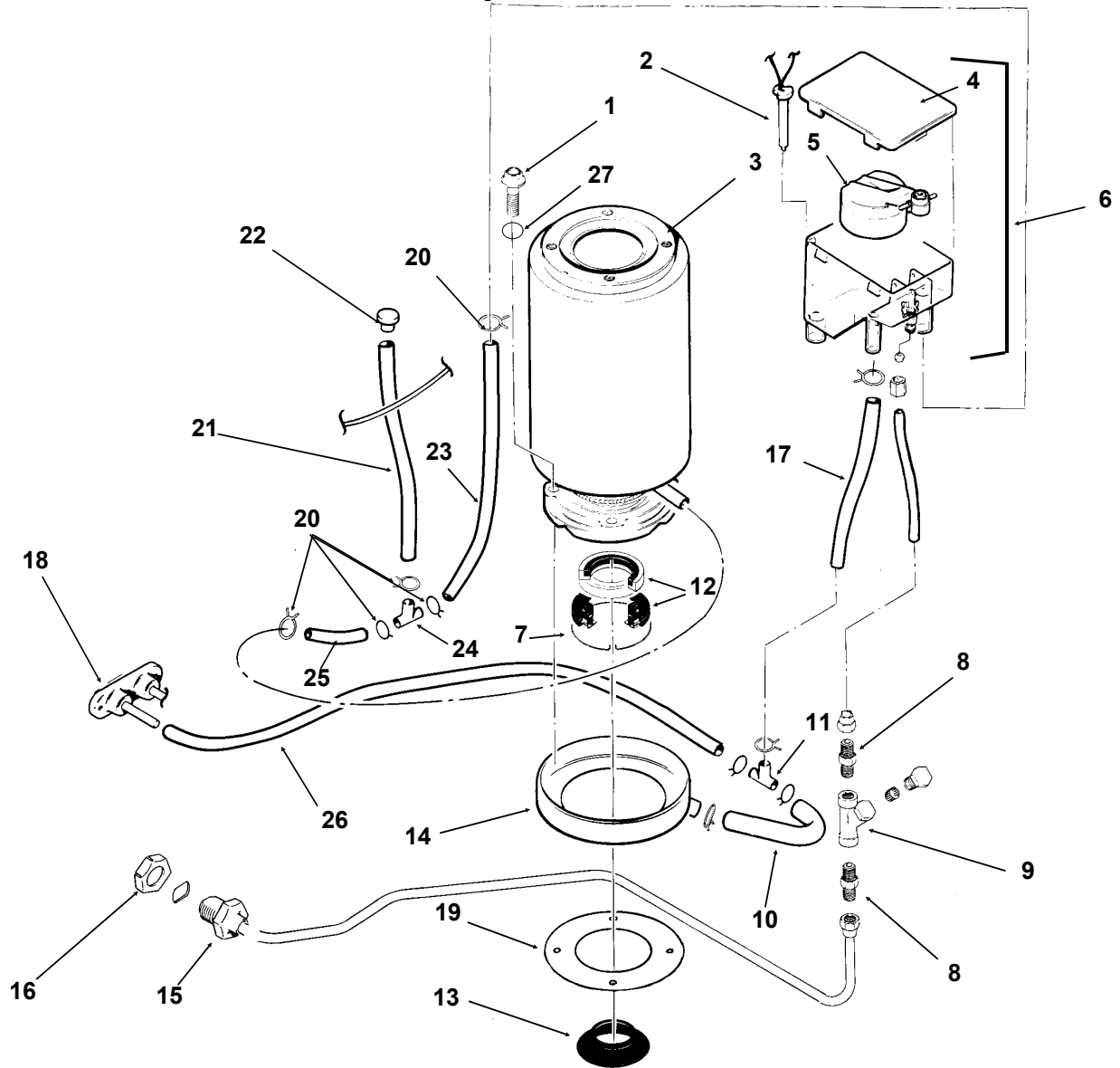

ITEM NUMBER	PART NUMBER	DESCRIPTION	ITEM NUMBER	PART NUMBER	DESCRIPTION
1	03-1420-03	Cap Screw	14	A32050-001	Drip Pan
2	A33101-022	Water Level Sensor	15	A27318-001	Water Inlet Fitting
3	A32890-020	Evaporator	16	03-1394-01	Pal Nut
4	02-2936-01	Res. Cover	17	13-0079-03	Res. Overflow, 8" req.
5	A32922-020	Float Assembly with pin, housing seal, rubber seat, insert & float	18	A34045-001	Drain Casting
	02-3190-01	Rubber seat	19	13-0704-00	Gasket
6	A32929-020	Reservoir Assembly	20	02-2814-08	Clamps
7	A32777-001	Retaining Ring for Seal	21	13-0674-06	Evap. Drain, 14" req.
8	16-0791-01	Half Union	22	13-0840-01	Plug
9	16-0162-00	Strainer	23	13-0674-06	Evap. Inlet Tube, 5" req.
10	13-0079-03	Tube, 3.2" req.	24	16-0670-01	Tee
11	16-0670-02	Tee	25	A33203-001	Tube, Preformed
12	02-0929-23	Water Seal	26	13-0079-03	Drain Tube, 24" req.
13	13-0868-01	Water Shed	27	03-1417-13	Lockwasher

# NM952R SERVICE PARTS

## Gearmotor

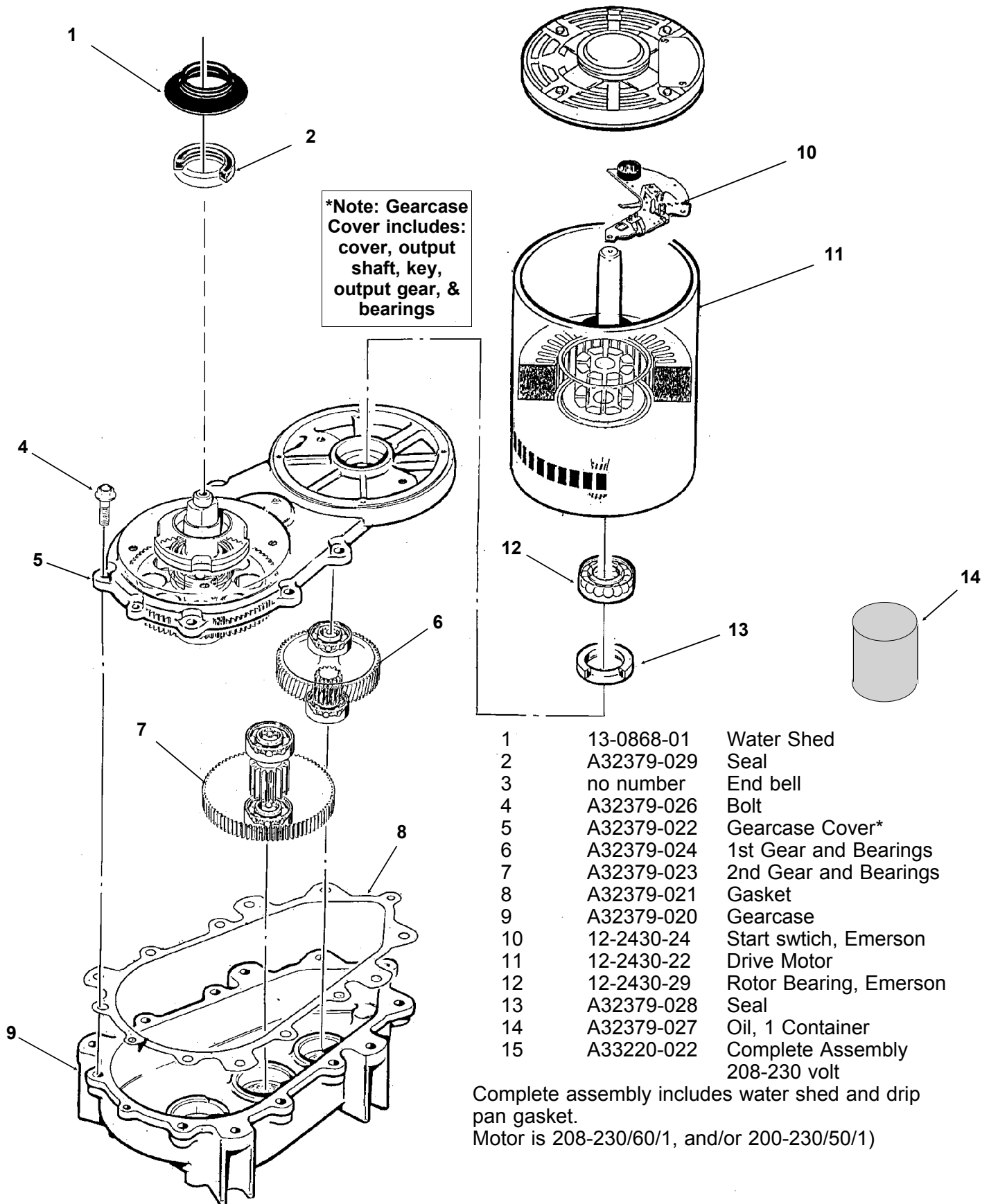

- |    |            |                                   |
|----|------------|-----------------------------------|
| 1  | 13-0868-01 | Water Shed                        |
| 2  | A32379-029 | Seal                              |
| 3  | no number  | End bell                          |
| 4  | A32379-026 | Bolt                              |
| 5  | A32379-022 | Gearcase Cover*                   |
| 6  | A32379-024 | 1st Gear and Bearings             |
| 7  | A32379-023 | 2nd Gear and Bearings             |
| 8  | A32379-021 | Gasket                            |
| 9  | A32379-020 | Gearcase                          |
| 10 | 12-2430-24 | Start switch, Emerson             |
| 11 | 12-2430-22 | Drive Motor                       |
| 12 | 12-2430-29 | Rotor Bearing, Emerson            |
| 13 | A32379-028 | Seal                              |
| 14 | A32379-027 | Oil, 1 Container                  |
| 15 | A33220-022 | Complete Assembly<br>208-230 volt |

Complete assembly includes water shed and drip pan gasket.

Motor is 208-230/60/1, and/or 200-230/50/1)

# NM952R SERVICE PARTS

## Evaporator, Bin Controls

Spanner Wrench:  
Part Number: A34773-001

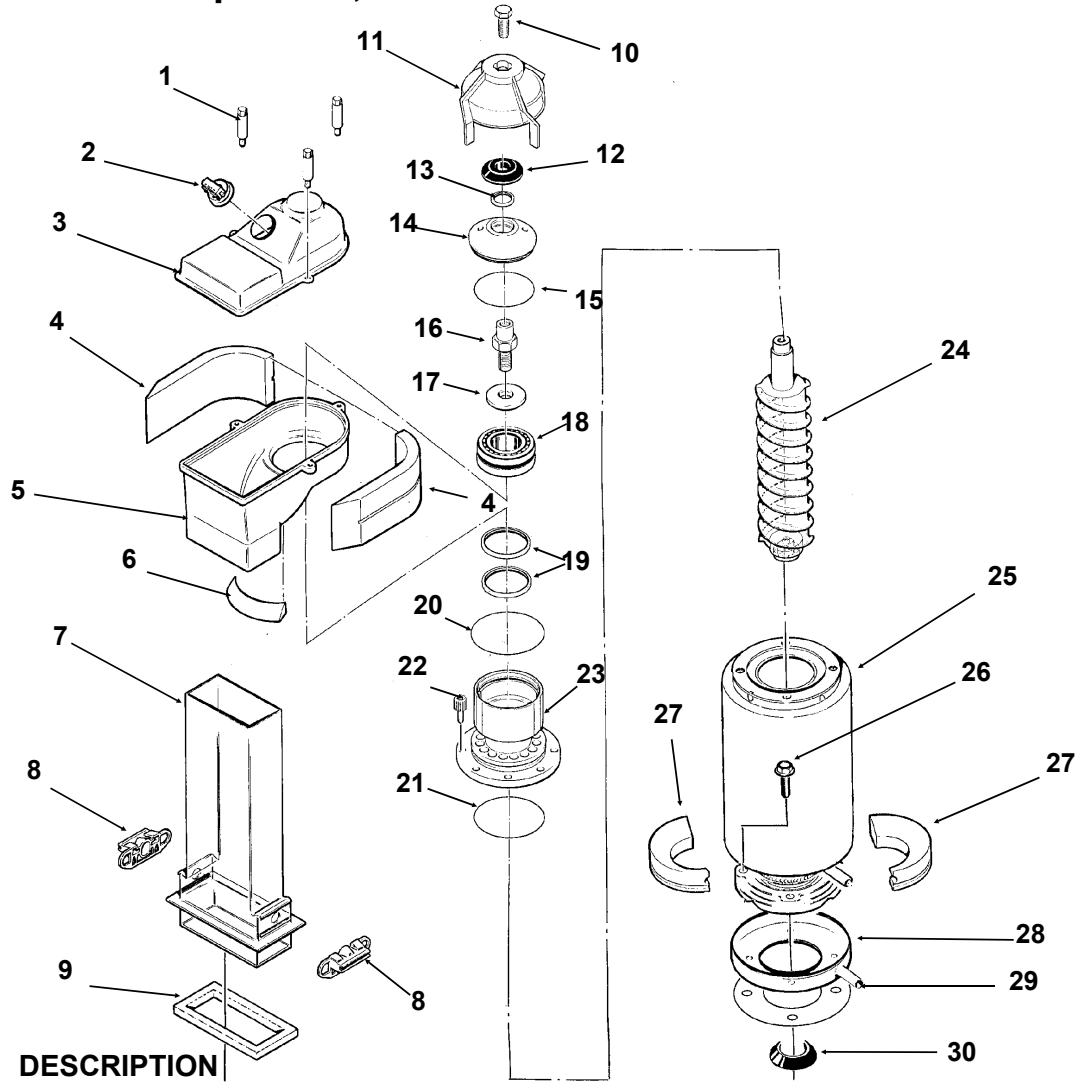

ITEM NUMBER	PART NUMBER	DESCRIPTION
1.	02-2933-01	Hex Stud
2.	A32891-020	Man. switch & hsng assy
	12-2398-01	Manual reset switch only
	12-2329-01	Auto reset switch only
	13-0617-53	O-Ring for above
3.	02-2930-01	Ice Chute Cover
4.	A32963-001	Insulation Top (half)
5.	02-2926-01	Ice Chute Body
	A32905-001	Clamp, chute to breaker
6.	A33102-001	Insulation Collar Inside
	A33210-001	Rubber Band
7.	02-2929-02	Ice Chute Lower
8.	A37708-021	Bin Controls
9.	A32930-001	Chute Gasket
10.	03-1405-52	Hex Cap Screw
11.	02-3001-01	Ice Sweep
12.	13-0871-01	Water Shed
13.	02-2978-01	Lip Seal
14.	02-3128-20	Breaker Cover
15.	13-0617-54	O-Ring
16.	08-0660-01	Auger Stud & Washer
17.	no number	part of item 16
18.	A34559-020	Bearing
19.	02-2977-01	Lip Seal
20.	13-0617-52	O-Ring
21.	13-0617-45	O-Ring
22.	03-1544-08	Soc. Head Screw
23.	A32900-020	Breaker
		(includes 13,14,15,18, 19 & 21)
24.	A38071-022	Auger
25.	A32890-020	Evaporator
26.	03-1405-41	Cap Screw
27.	A32962-001	Insulation Bot. (half)
	A32962-002	Insulation half
28.	A32050-001	Drip Pan
29.	13-0704-00	Drip Pan Gasket
30.	13-0868-01	Water Shed

# NM952R SERVICE PARTS

## Control Box

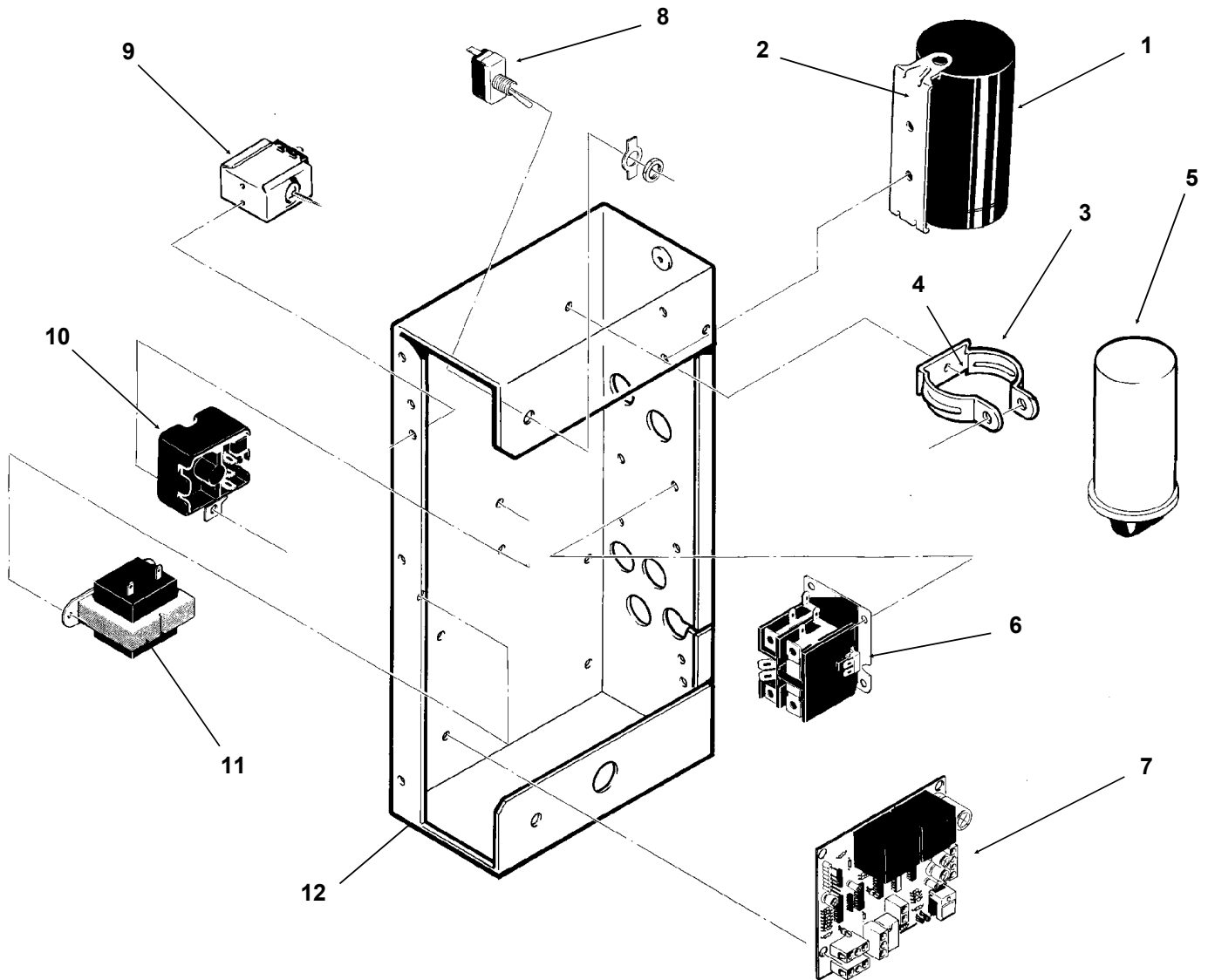

ITEM NUMBER	PART NUMBER	DESCRIPTION	ITEM NUMBER	PART NUMBER	DESCRIPTION
1	18-1901-48	Start Capacitor	7	A37750-021	Circuit Board
	18-4300-50	Start Capacitor Cap.	8.	12-0426-01	Master Switch
2.	18-2200-39	Start Capacitor Bracket	9.	11-0420-23	Pump Down Control
	03-1638-04	Screw	10	18-1903-46	Potential Relay
	03-1417-15	Lockwasher	11.	12-2285-22	Transformer
3.	A32872-001	Run Cap Bracket	12	no number	Control Box Assy
	03-1652-02	Bolt	NOT ILLUSTRATED		
	03-0255-04	Wing Nut	13.	12-2337-02	3 Pin Plug Assy (Safety Circuit to Circuit Board)
4.	03-1638-03	Screw	14.	12-2340-01	4 Pin Plug Assy (Transformer to Circuit Board)
5.	18-1902-45	Run Capacitor	15.	A34055-001	Control box cover
6.	12-2469-03	Single Phase Contactor			
	12-0739-02	Three Phase Contactor			



# NM952R SERVICE PARTS

## Remote Condenser

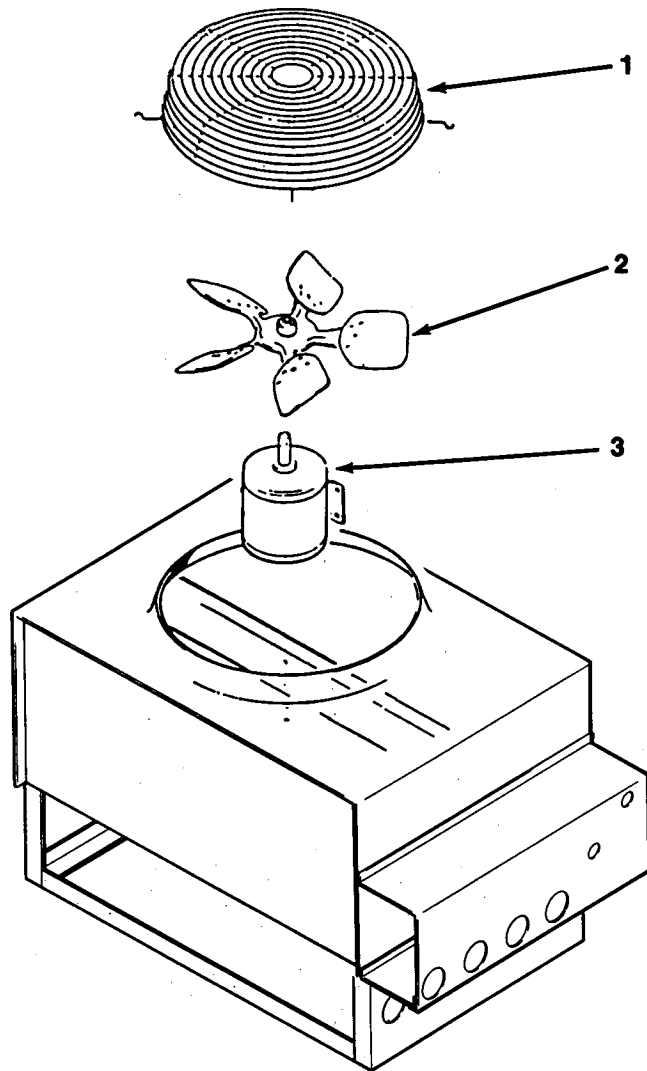

RC1022-32A or RC1222-32A

ITEM NUMBER	PART NUMBER	DESCRIPTION
1.	02-2628-01	Fan Guard
2.	18-6304-01	Fan Blade
3.	18-5301-01	Fan Motor
4.	16-1057-01	Line connection, female half, 3/8"
5.	16-1057-02	Line connection, female half, 1/2"

# NM952R SERVICE PARTS

## Component Layout Diagram, 208-230/60/1

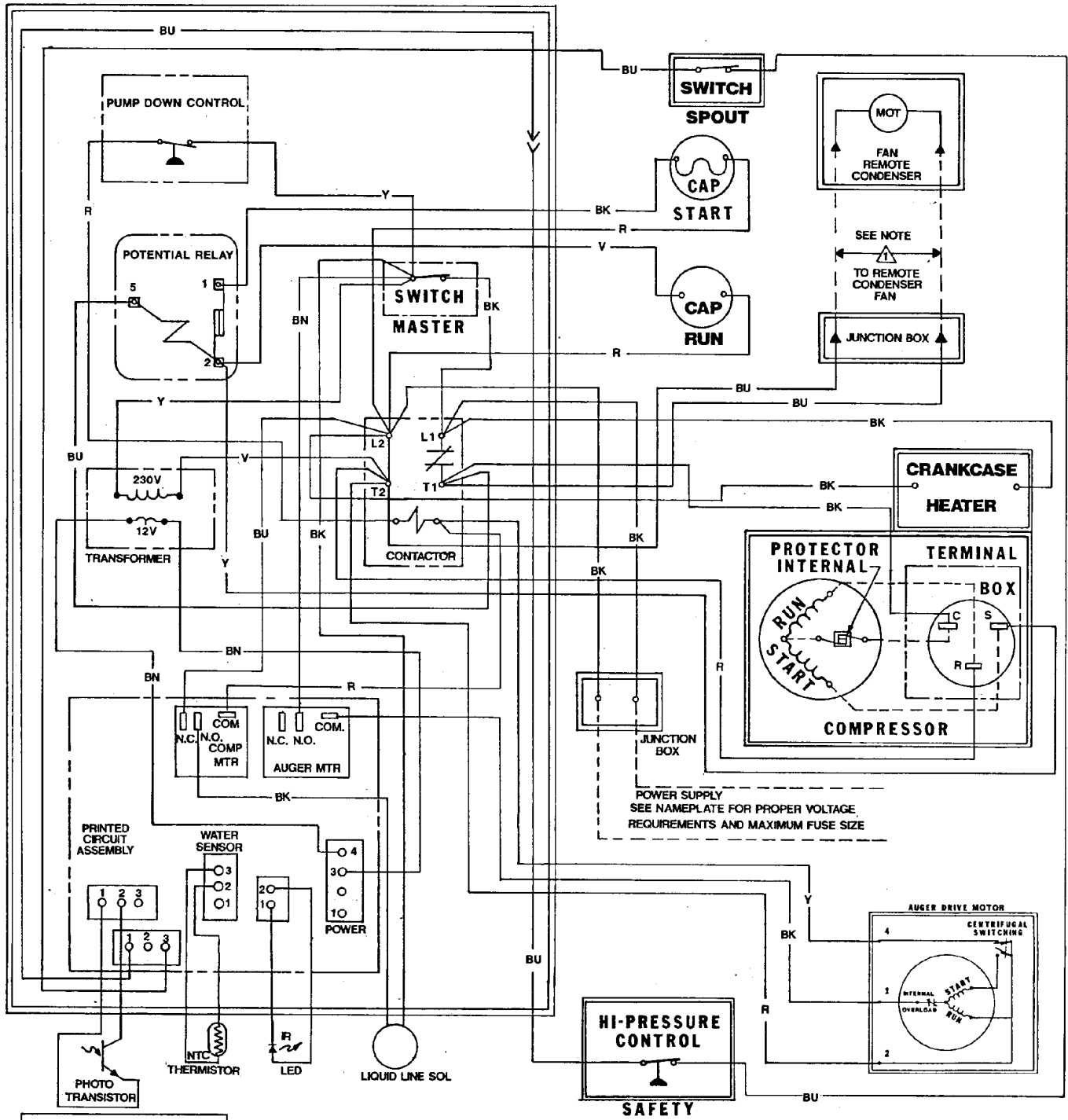

**A34492-032**

# NM952R SERVICE PARTS

## Schematic Diagram, 208-230/60/1

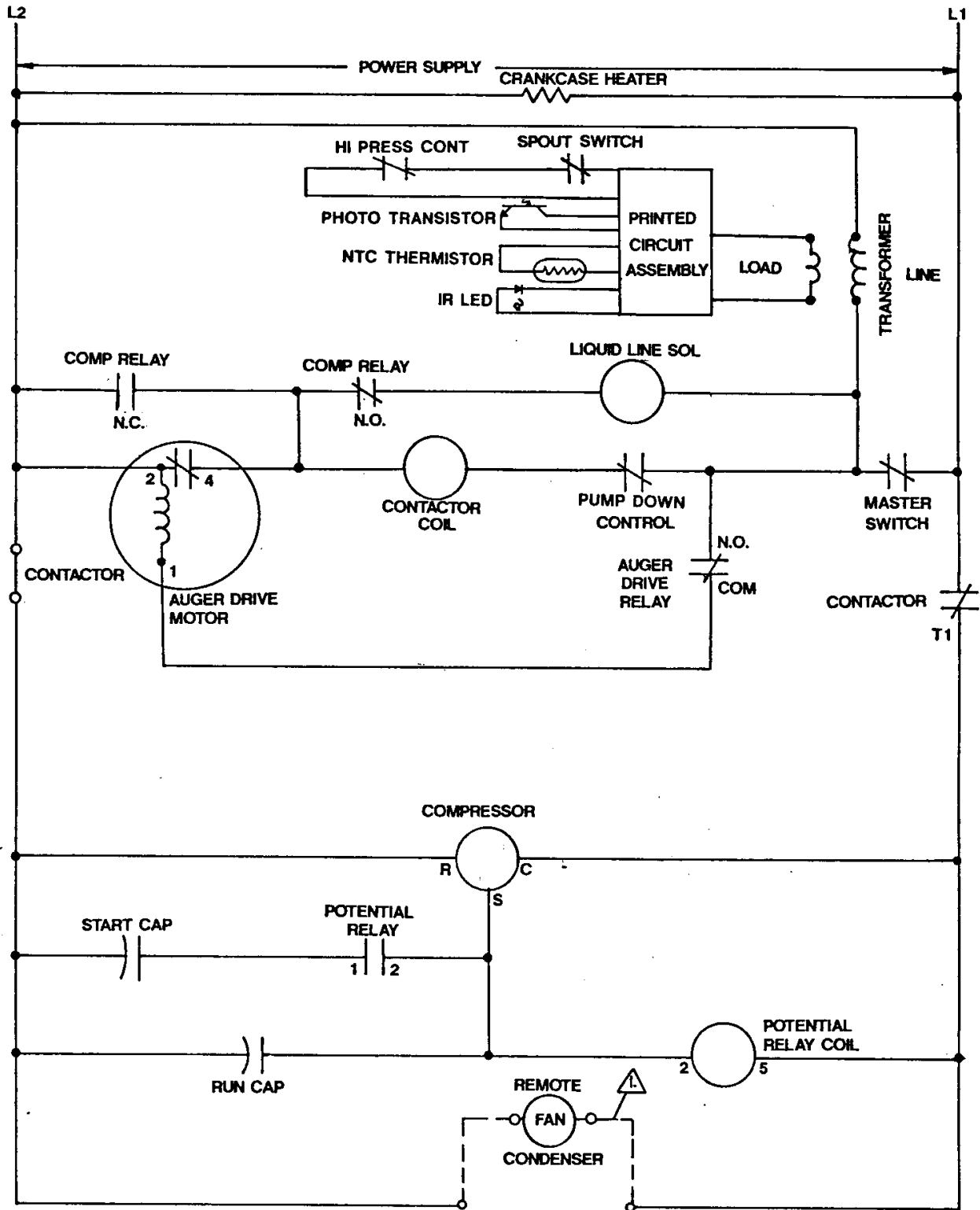

**USE COPPER CONDUCTORS ONLY THIS UNIT MUST BE GROUNDED**

All Controls Shown in Normal Ice Making Mode.

Note: Dashed lines indicate field wiring which must be installed in accordance with the National Electric Code Using a Minimum of 14 ga. awg. wire.

# NM952R SERVICE PARTS

## Component Layout Diagram, 208-230/60/3

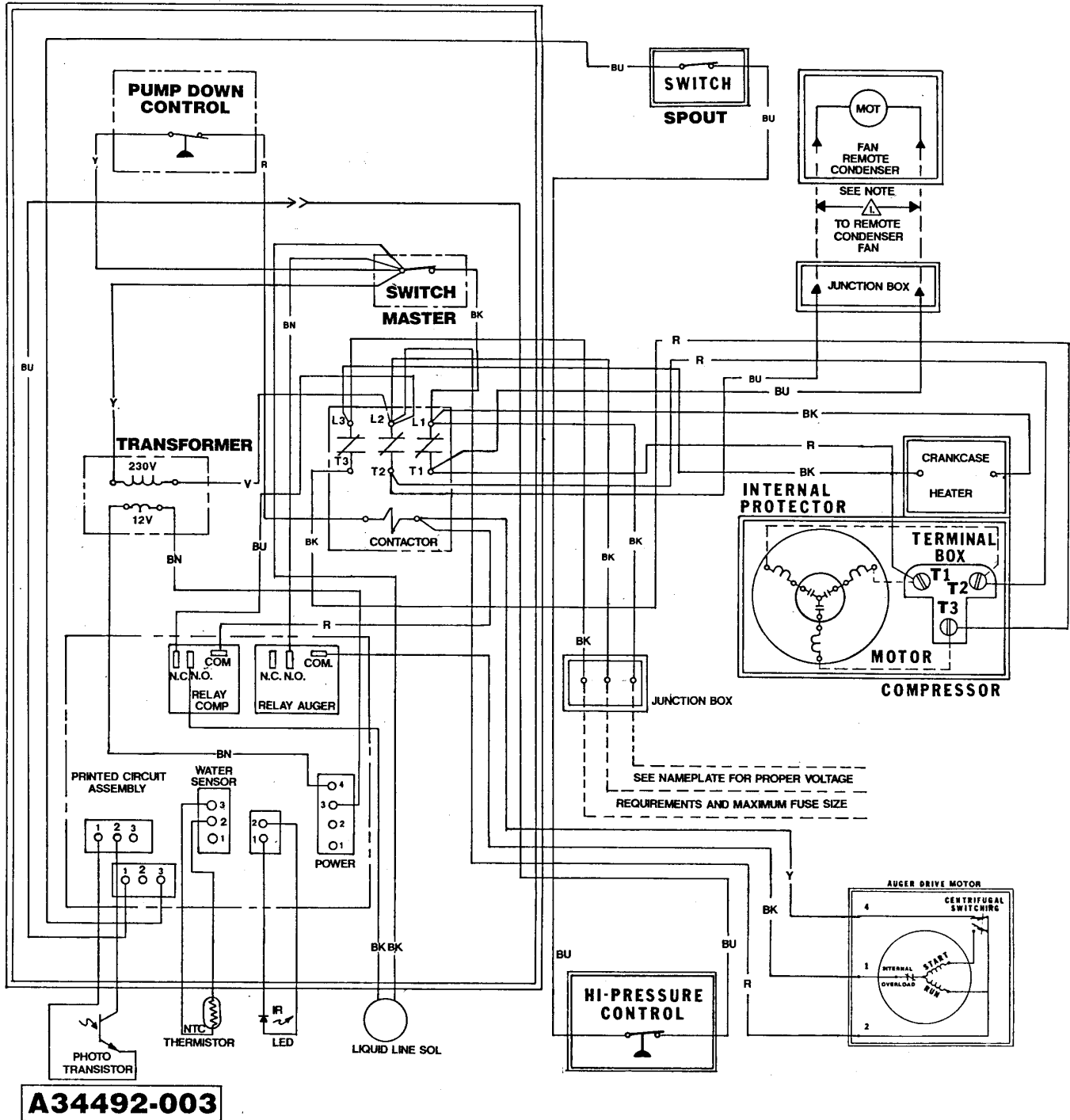

# NM952R SERVICE PARTS

## Schematic Diagram, 208-230/60/3

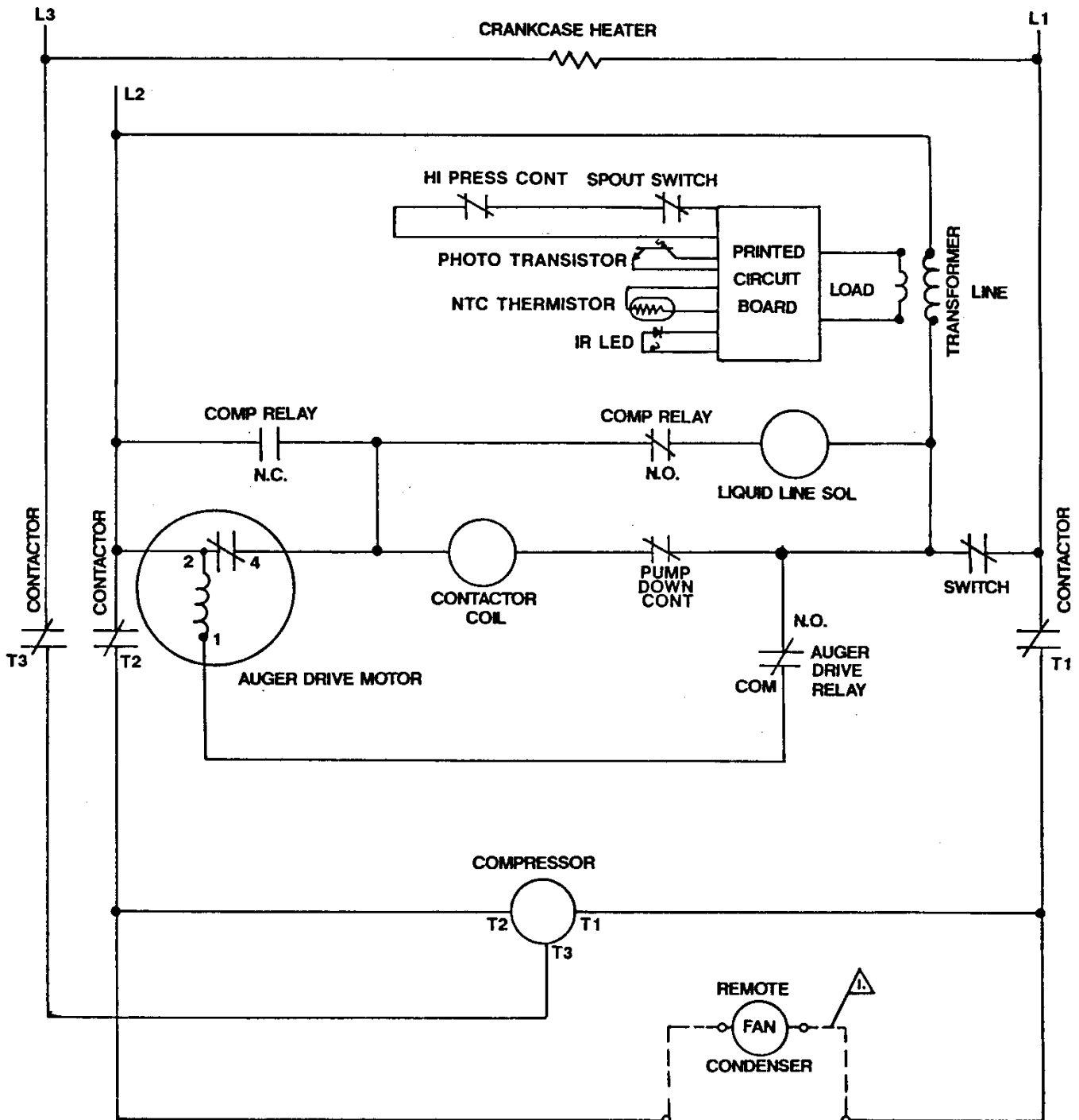

**USE COPPER CONDUCTORS ONLY THIS UNIT MUST BE GROUNDED**

All Controls Shown in Normal Ice Making Mode.

Note: Dashed lines indicate field wiring which must be installed in accordance with the National Electric Code Using a Minimum of 14 ga. awg. wire.