

# NME1254 and FME1504 SERVICE PARTS

This parts list contains the part numbers and descriptions of the service parts for the NME1254 and FME1504 air and water cooled. The water cooled condenser changed between the A and B series. Be sure to check the complete model number before selecting the condenser part number.

## Table of Contents

PANELS . . . . .	2
AIR COOLED REFRIGERATION . . . . .	3
WATER COOLED REFRIGERATION . . . . .	4
NME EVAPORATOR . . . . .	5
FME EVAPORATOR . . . . .	6
CONTROL BOX . . . . .	7
GEARMOTOR . . . . .	8
RESERVOIR, DRAINS, ICE CHUTE, ICE LEVEL SENSORS . . . . .	9
WIRING DIAGRAMS . . . . .	10

# NME1254 and FME1504 SERVICE PARTS PANELS

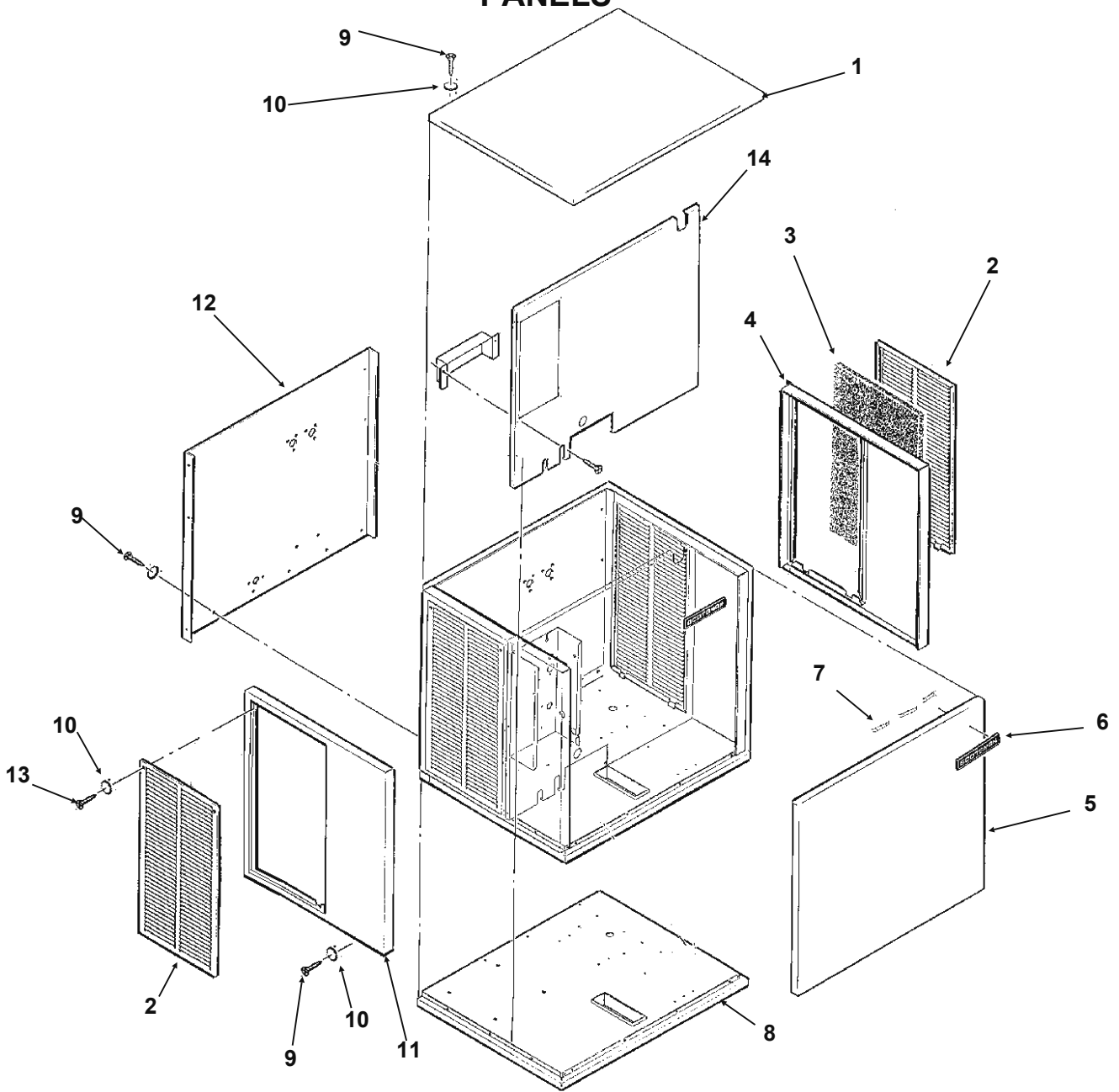

ITEM NUMBER	PART NUMBER	DESCRIPTION	ITEM NUMBER	PART NUMBER	DESCRIPTION
1.	A32159-002	Top Panel Stainless	6.	15-0808-01	Emblem
2.	A33946-002	Service Panel for S.S.	7.	03-0271-00	Clip For Emblem (3)
3.	A32975-001	Filter (air cooled only)	8.	A35955-001	Base Assembly
4.	A32162-002	Right End Panel S.S.	9.	03-1531-01	Screw
5.	A32160-002	Front Panel S.S.	10.	03-1417-27	Washer
			11.	A32163-002	Left End Panel S.S.
			12.	A32202-0003	Back panel
			13.	03-1404-12	Screw
			14.	A35828-015	Retainer

# NME1254 and FME1504 SERVICE PARTS

## AIR COOLED REFRIGERATION

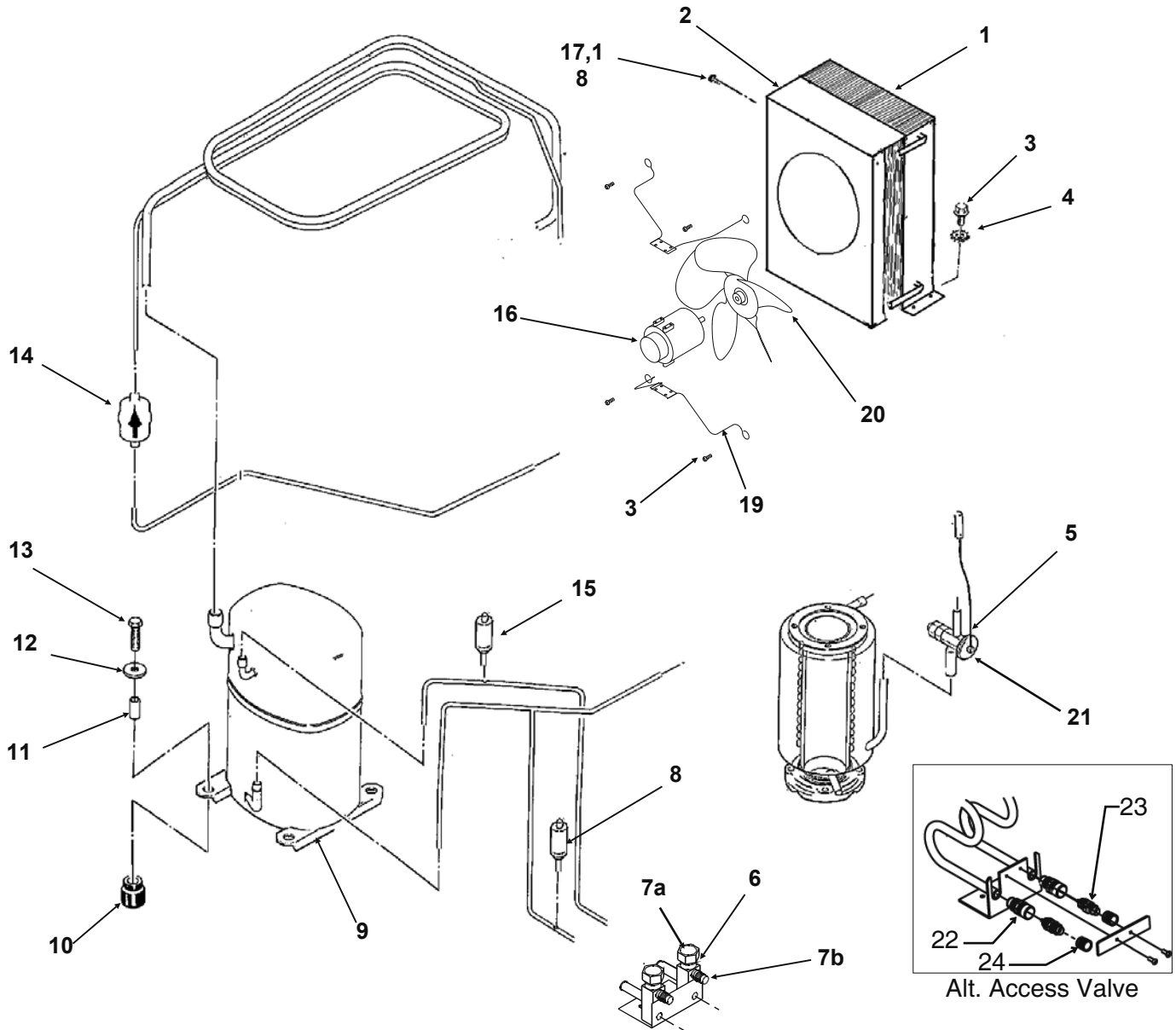

ITEM NUMBER	PART NUMBER	DESCRIPTION
1.	18-8733-01	Air Cooled Conden.
2.	A35717-001	Shroud
3.	03-1645-01	Bolt
4.	03-1417-09	Washer
5.	11-0482-21	Expansion Valve
6.	16-0832-20	Access valve
7a.	16-0832-02	Stem cap
7b.	16-0832-03	Core cap
8.	11-0501-22	Hi Pressure Control
9.	18-8726-23	208-230/60/1 Comp. w/drier
This compressor has an internal overload.		
10.	18-2200-28	Grommet
11.	18-2200-27	Sleeve

ITEM NUMBER	PART NUMBER	DESCRIPTION
12.	03-1407-07	Washer
13.	03-1405-20	Bolt
14.	02-3319-02	Drier
15.	11-0502-21	L. P. Control
16.	18-5105-02	Fan Motor
	03-1531-08	Screws, motor to bracket
17.	03-1404-03	Screw
18.	03-1417-27	Washer
19.	02-3333-01	Fan Motor Bracket
20.	18-3732-01	Fan Blade
21.	A32961-020	Insulation for TXV
22.	16-1137-01	Access valve body
23.	16-1139-01	Core
24.	16-1140-01	Cap

# NME1254 and FME1504 SERVICE PARTS WATER COOLED REFRIGERATION

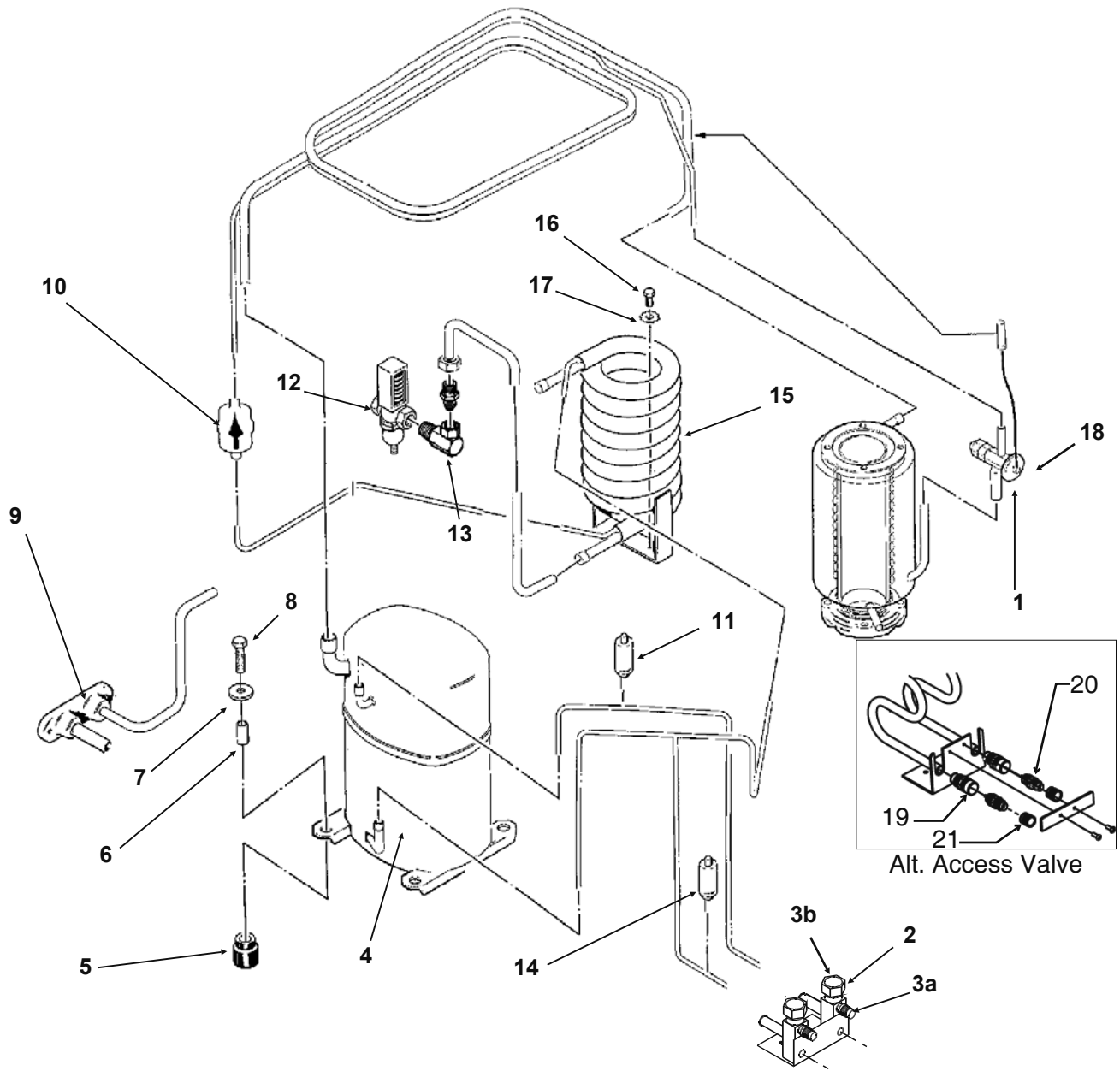

ITEM NUMBER	PART NUMBER	DESCRIPTION	ITEM NUMBER	PART NUMBER	DESCRIPTION
1.	11-0482-21	Expansion Valve	11.	11-0502-21	Lo Press. Control
2.	16-0832-20	Access valve	12.	11-0478-01	Water Reg. Valve
3a.	16-0832-03	Core cap	13.	16-0401-02	Elbow
3b.	16-0832-02	Stem cap	14.	11-0501-22	Hi Pressure Control
4.	18-8726-23	Compressor 208-230/60/1 Includes drier, Overload is internal	15.	18-6900-25	A series WC Condenser
5.	18-2200-28	Grommet		18-8874-21	B series WC condenser
6.	18-2200-27	Sleeve	16.	03-1645-01	Screw
7.	03-1407-07	Washer	17.	03-1417-09	Washer
8.	03-1405-20	Bolt	18.	A32961-020	Insulation for TXV
9.	A31878-004	Drain	19.	16-1137-01	Access valve body
10.	02-3319-02	Drier	20.	16-1139-01	Core
			21.	16-1140-01	Cap

# NME1254 and FME1504 SERVICE PARTS NME EVAPORATOR

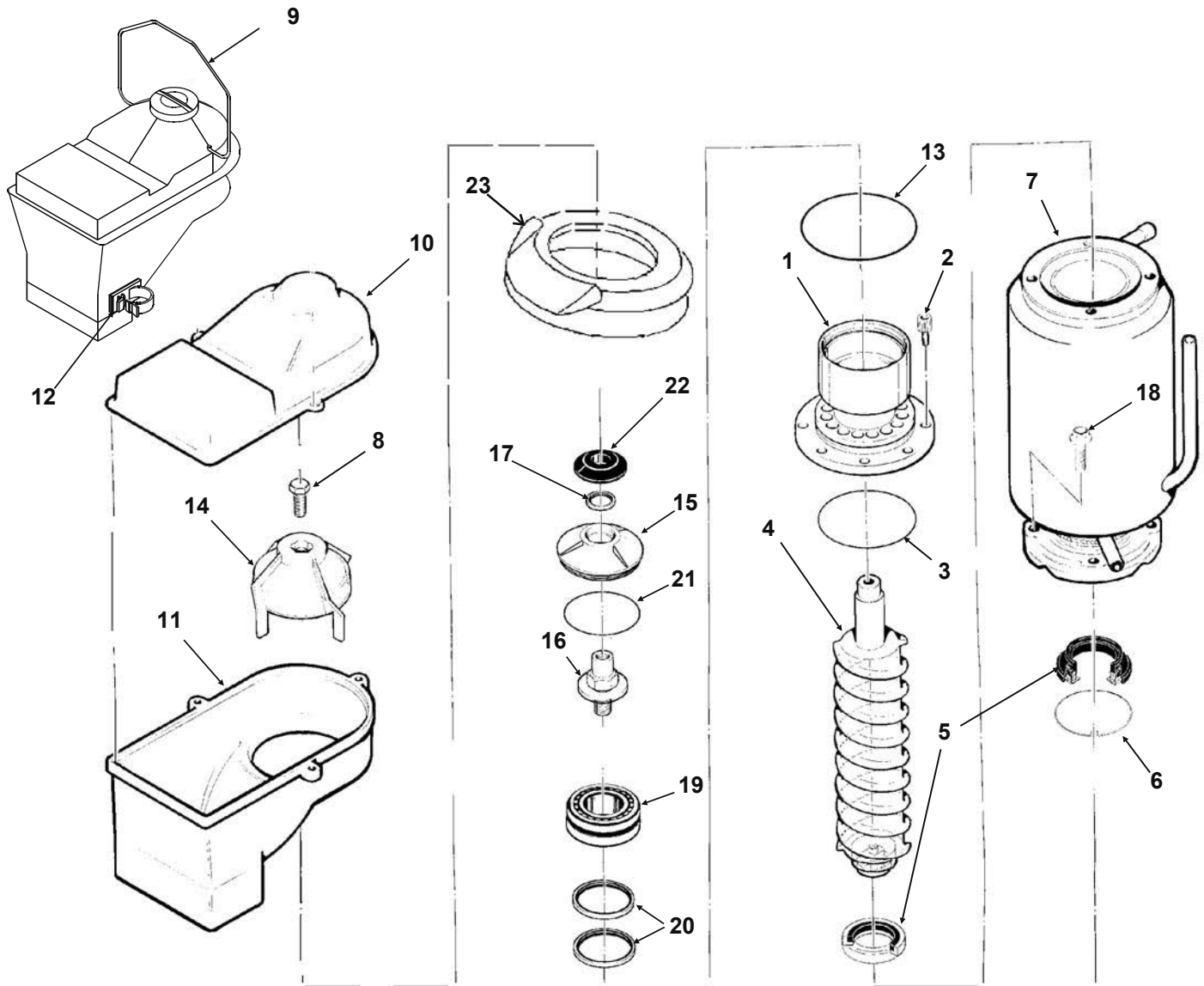

ITEM NUMBER	PART NUMBER	DESCRIPTION	ITEM NUMBER	PART NUMBER	DESCRIPTION
1.	A32900-020	Breaker Includes Items 19 & 20	10.	02-2930-04	Ice Chute Cover
2.	03-1544-08	Soc. head Screw	11.	02-3841-01	Ice Chute Body w/ins.
3.	13-0617-45	O-ring	12.	02-3268-01	Drain hose clip
4.	A38071-022	Auger	13.	13-0617-52	O-ring
5.	02-0929-23	Water Seal	14.	02-3001-01	Ice Sweep
6.	A32777-001	Ring, Water Seal	15.	02-3128-20	Breaker Cover
7.	A32890-020	Evaporator	16.	08-0660-01	Auger Stud
8.	03-1405-52	Hex Cap Screw	17.	02-2978-01	Lip Seal
9.	A34969-001	Bail clamp	18.	03-1405-41	Cap screw
			19.	A34559-020	Bearing
			20.	02-2977-01	Lip Seal
			21.	13-0617-54	O-Ring
			22.	13-0871-01	Water Shed
			23.	13-0929-02	Insulation donut

**Note:** Evaporator is not available assembled with internal parts.

# NME1254 and FME1504 SERVICE PARTS FME EVAPORATOR

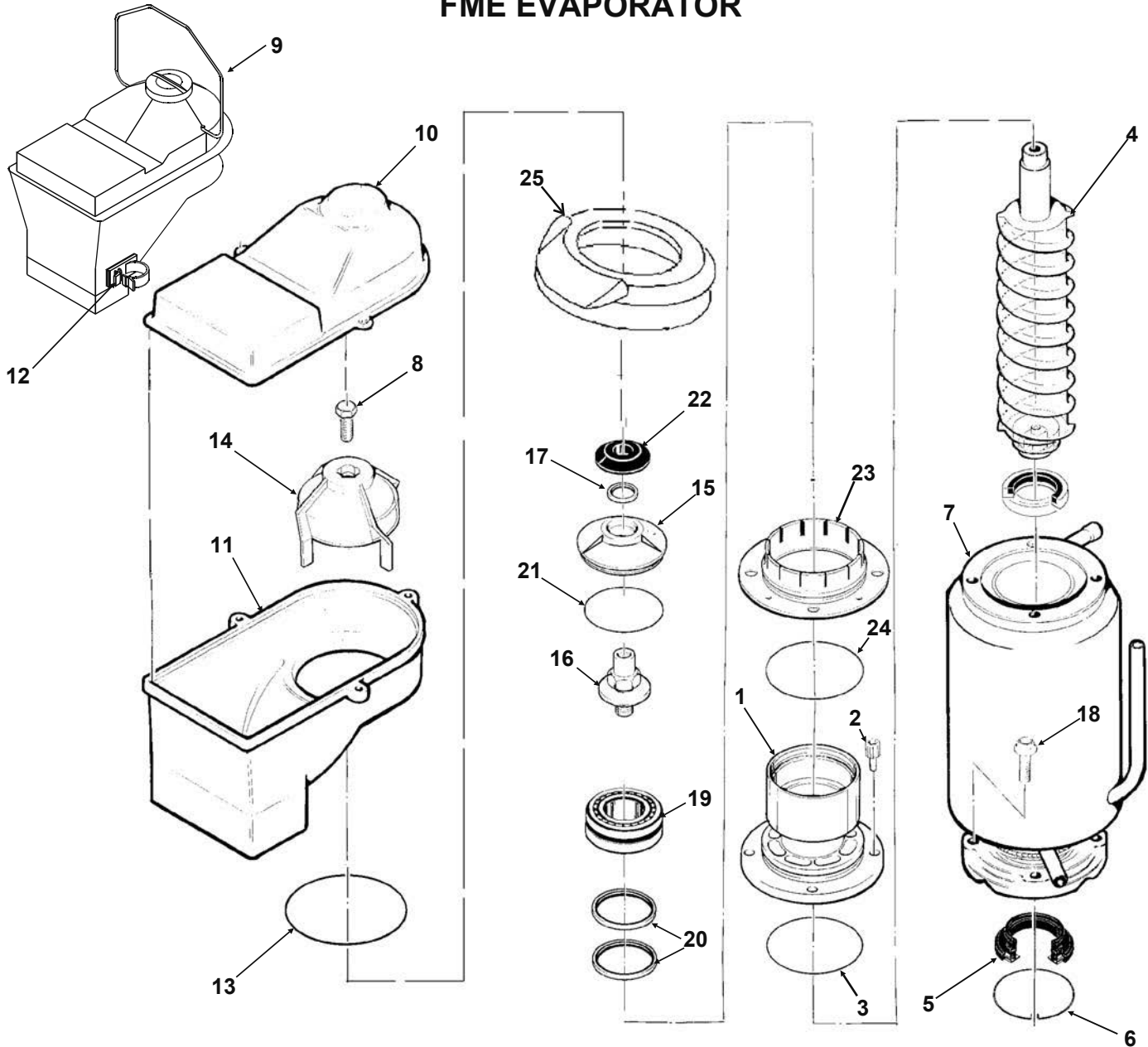

ITEM NUMBER	PART NUMBER	DESCRIPTION
1.	A34505-020	Breaker Includes Items 19 & 20
2.	03-1544-08	Soc. head Screw
3.	13-0617-45	O-ring
4.	A38071-022	Auger
5.	02-0929-23	Water Seal
6.	A32777-001	Ring, Water Seal
7.	A32890-020	Evaporator
8.	03-1405-52	Hex Cap Screw
9.	A34969-001	Bail clamp
10.	02-2930-04	Ice Chute Cover
11.	02-3841-01	Ice Chute Body w/ins.

**Note:** Evaporator is not available assembled with internal parts.

ITEM NUMBER	PART NUMBER	DESCRIPTION
12.	02-3268-01	Drain hose clip
13.	13-0617-52	O-ring
14.	02-3001-01	Ice Sweep
15.	02-3128-20	Breaker Cover
16.	08-0660-01	Auger Stud
17.	02-2978-01	Lip Seal
18.	03-1405-41	Cap screw
19.	A34559-020	Bearing
20.	02-2977-01	Lip Seal
21.	13-0617-54	O-Ring
22.	13-0871-01	Water Shed
23.	02-2916-01	Slotted collar
24.	13-0617-49	O-ring
25.	13-0929-01	Insulation donut

# NME1254 and FME1504 SERVICE PARTS CONTROL BOX

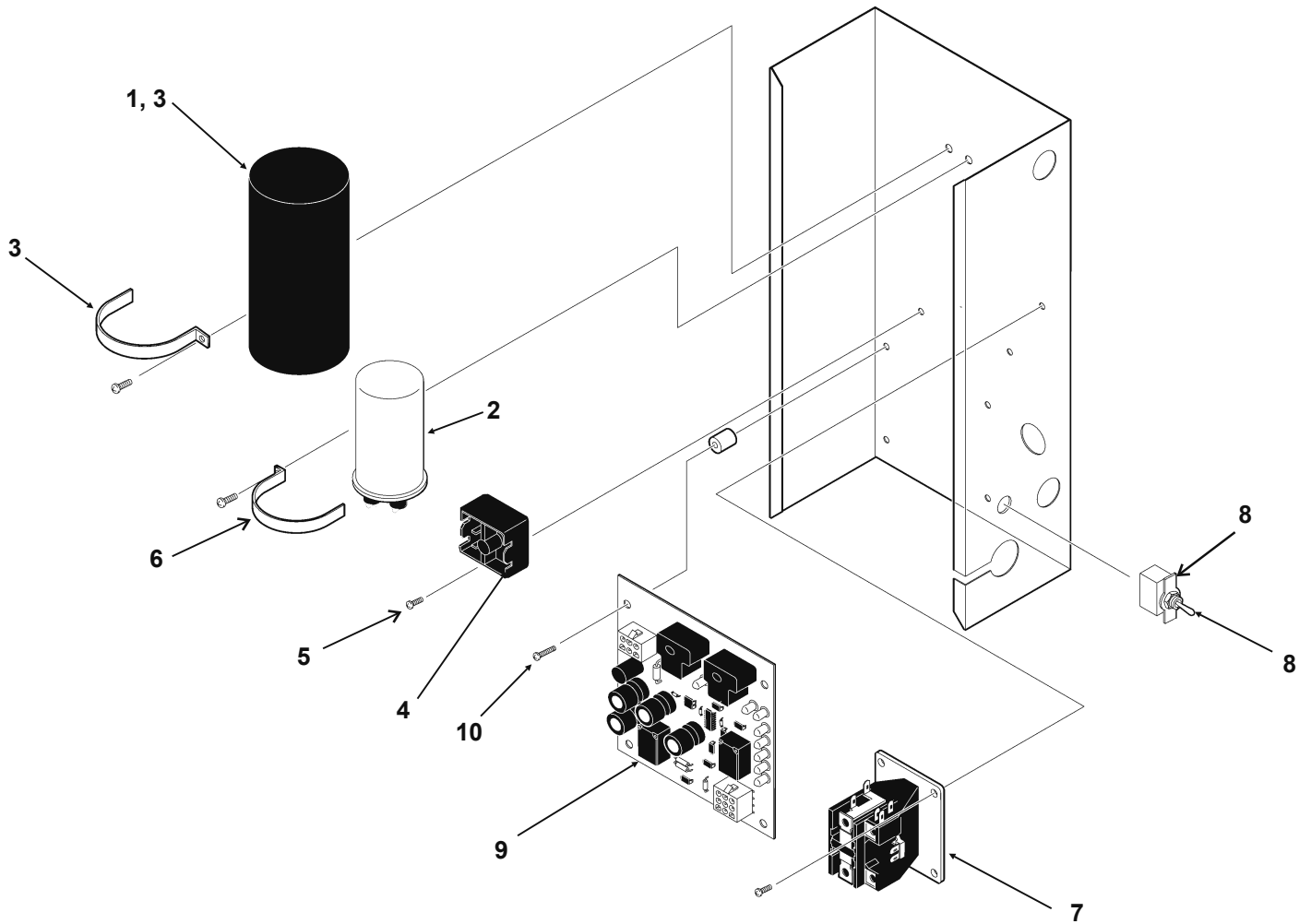

ITEM NUMBER	PART NUMBER	DESCRIPTION
1.	18-1901-15	Start Capacitor
2.	18-1902-53	Run Capacitor
3.	A33971-002	Start Cap. Bracket
4.	18-1903-33	Relay
5.	03-1638-03	Screw
6.	A32872-001	Run Cap. Bracket
7.	12-2469-02	1 Phase Contactor
8.	12-0426-01	Mode Switch

ITEM NUMBER	PART NUMBER	DESCRIPTION
9.	12-2835-22	Circuit Board
10.	12-2350-01	Stand off
11.	No Number	Control Box
12.	A32896-001	Cont. Box Cover

Not shown:

13	12-2745-01	Low voltage harness, 9 pin
14	12-2747-01	High voltage harness, 6 pin

# NME1254 and FME1504 SERVICE PARTS GEARMOTOR

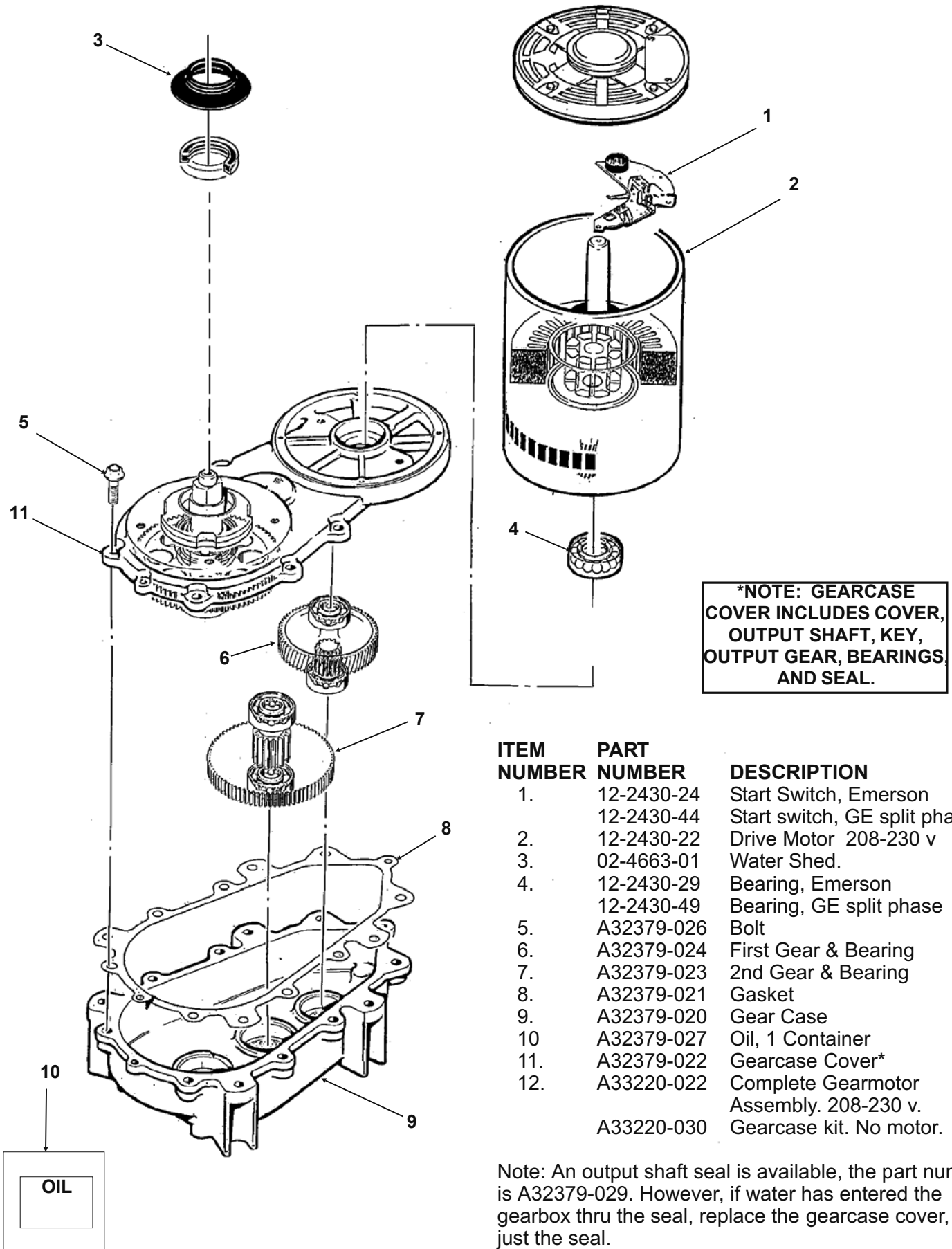

\*NOTE: GEARCASE COVER INCLUDES COVER, OUTPUT SHAFT, KEY, OUTPUT GEAR, BEARINGS AND SEAL.

ITEM NUMBER	PART NUMBER	DESCRIPTION
1.	12-2430-24	Start Switch, Emerson
	12-2430-44	Start switch, GE split phase
2.	12-2430-22	Drive Motor 208-230 v
3.	02-4663-01	Water Shed.
4.	12-2430-29	Bearing, Emerson
	12-2430-49	Bearing, GE split phase
5.	A32379-026	Bolt
6.	A32379-024	First Gear & Bearing
7.	A32379-023	2nd Gear & Bearing
8.	A32379-021	Gasket
9.	A32379-020	Gear Case
10.	A32379-027	Oil, 1 Container
11.	A32379-022	Gearcase Cover*
12.	A33220-022	Complete Gearmotor Assembly. 208-230 v.
	A33220-030	Gearcase kit. No motor.

Note: An output shaft seal is available, the part number is A32379-029. However, if water has entered the gearbox thru the seal, replace the gearcase cover, not just the seal.



# NME1254 and FME1504 SERVICE PARTS

## RESERVOIR, DRAINS, ICE CHUTE, ICE LEVEL SENSORS

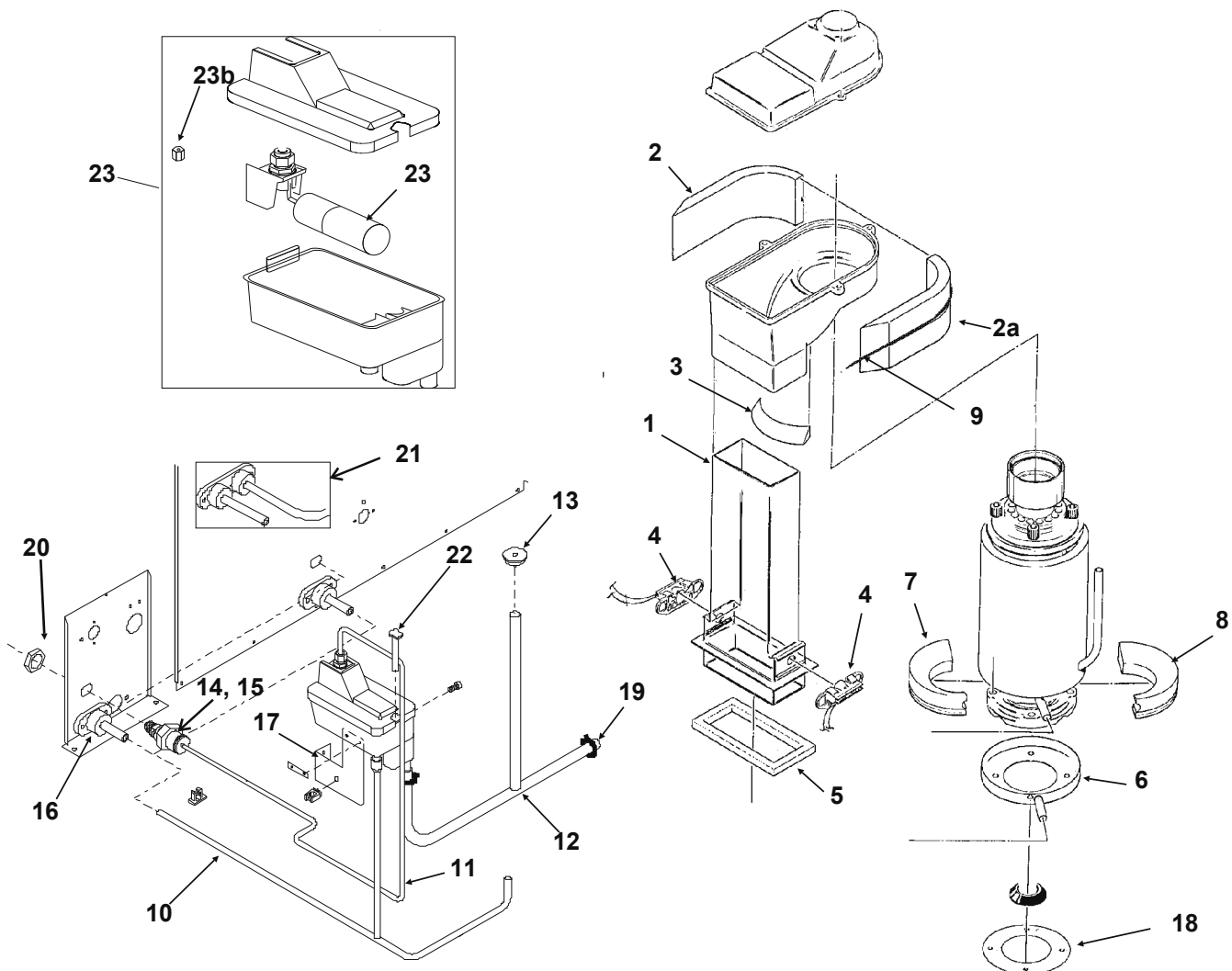

ITEM NUMBER	PART NUMBER	DESCRIPTION
1.	02-2929-04	Ice Chute Lower
2.	A32963-002	Insulation collar top*
2a	A32963-001	Insulation collar, top*
3.	A33102-001	Insulation Collar Inside*
4.	A37708-021	Ice level sensor set
5.	A32930-001	Chute Gasket
6.	02-3837-01	Drip Pan
7.	02-4358-01	Insulation Collar
8.	same as item 7,	use one per unit.
9	A35419-020	Strap kit
10.	02-3836-01	Drain hose
11.	13-0895-01	Inlet tube, 4 ft req.
12.	A36154-002	Preformed Hose
13.	13-0840-01	Plug
14.	16-0835-01	Water inlet fitting
15.	16-1039-01	Male connector

ITEM NUMBER	PART NUMBER	DESCRIPTION
16.	02-3692-22	Drain fitting
17.	A35956-015	Reservoir bracket
18.	13-0704-00	Drip pan gasket
19.	02-1338-00	Hose clamp
20.	03-1394-01	Pal Nut
21.	A31878-004	Drain - Water Cooled
22.	12-2760-21	Water level sensor
23.	02-3266-01	Float & Reservoir complete
23a	02-3266-02	Float valve
23b	02-3266-03	Plunger

\* items 2, 2a and 3 no longer used after Oct. 2000. Insulation part of ice chute body & donut. See pages 5 and 6.

# NME1254 and FME1504 SERVICE PARTS

## AIR AND WATER COOLED, 208-230/60/1

17-2678-01

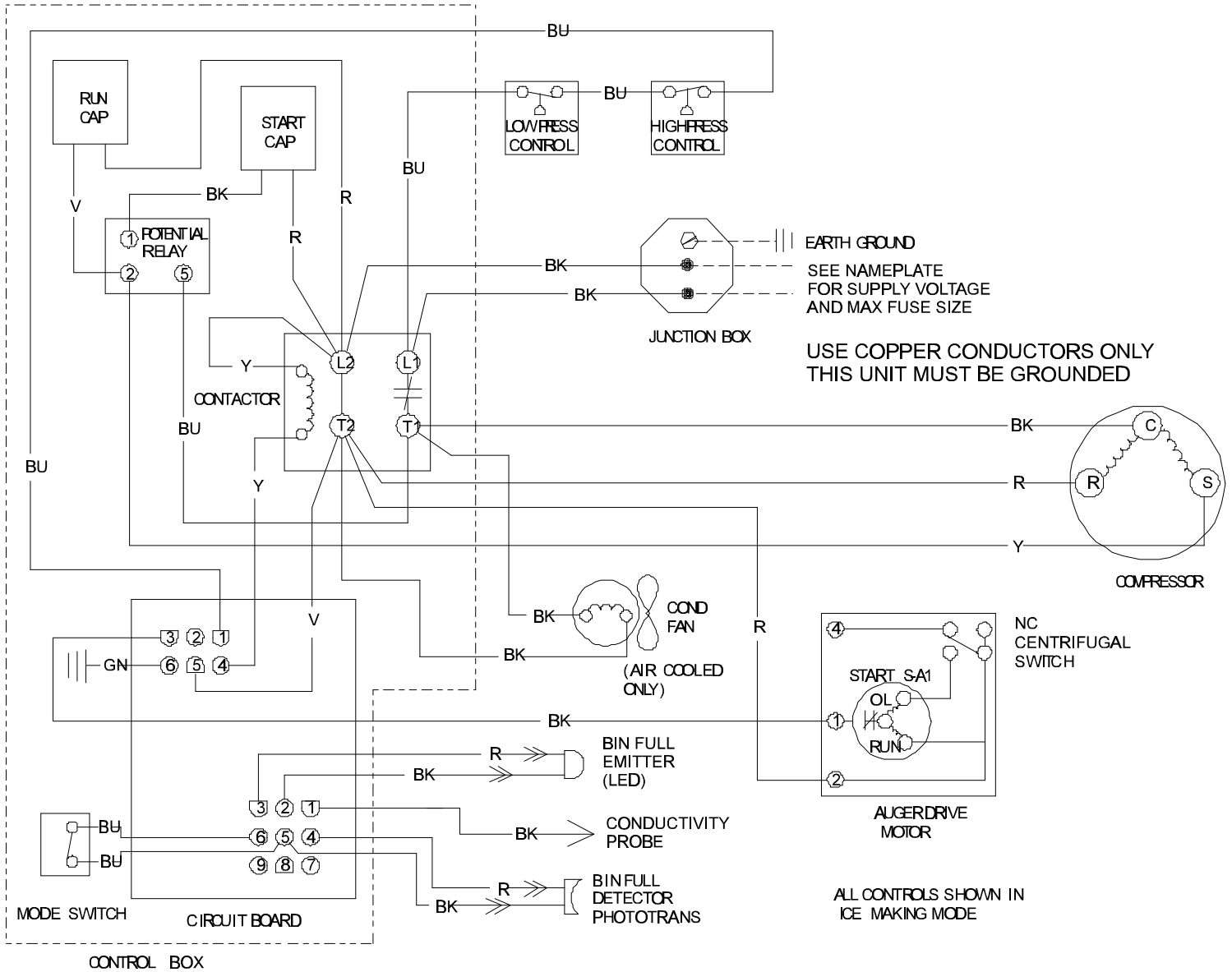

# NME1254 and FME1504 SERVICE PARTS

## AIR AND WATER COOLED, 208-230/60/1

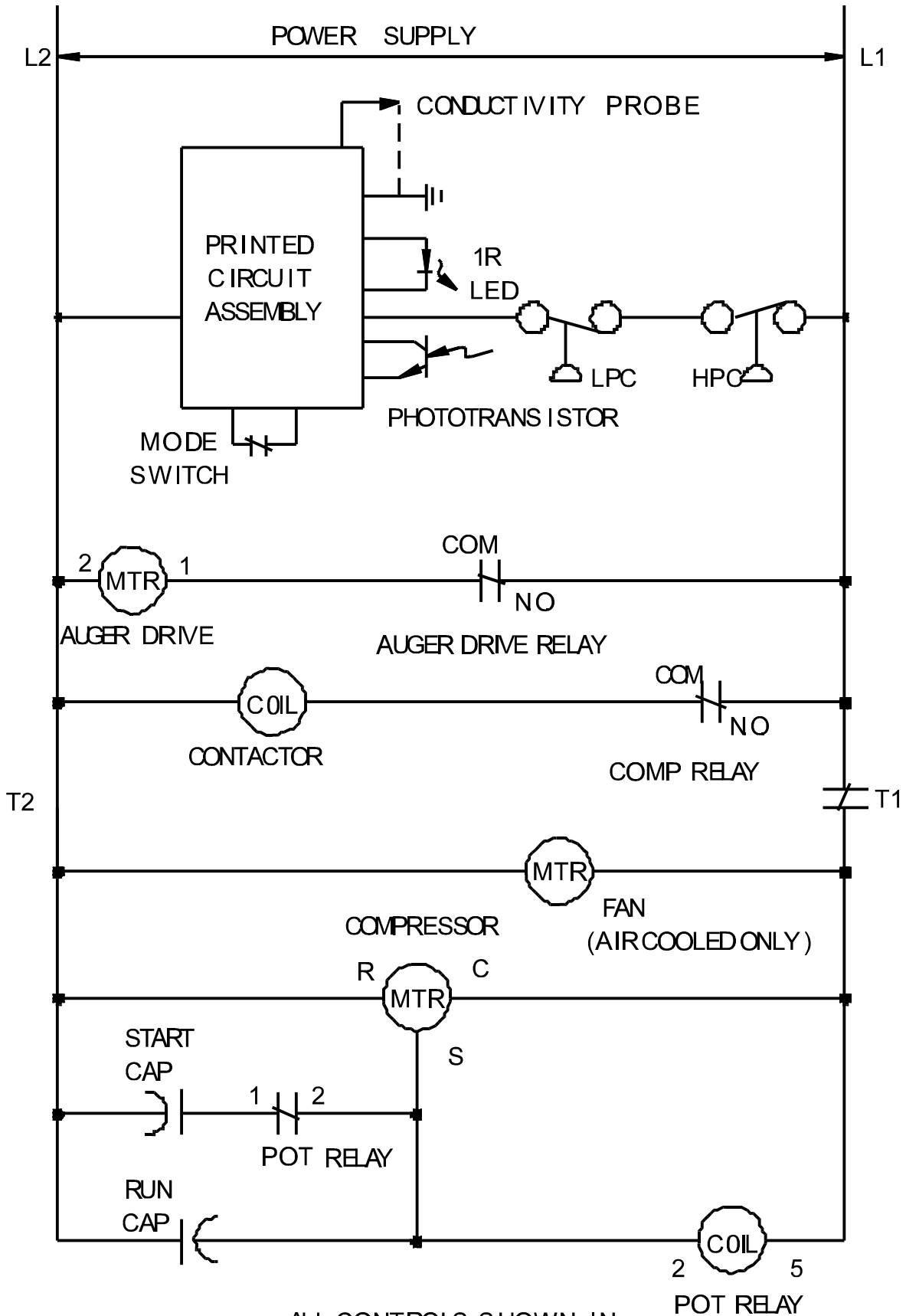

ALL CONTROLS SHOWN IN  
ICE MAKING MODE

**SCOTSMAN**®

Bulletin Number: PS-14-96

Bulletin Date: September 1996

# SERVICE BULLETIN

## Subject: NME, FME, NSE, NDE and TDE550/650 Top Bearing Lubrication

Two parts have been made available as helpful aids to use when lubricating the top bearing.

1. **02-3559-01** is a needle that snaps onto a standard grease gun fitting. Use it to insert and deeply pack the proper lubricant into the top bearing.
2. **A36808-001** is a tube of the proper lubricant, also designed to fit a standard grease gun.

Both numbers are in the parts price list.

Needle, shown inserted into bearing

