

INTRODUCTION

To the owner or user: The service manual you are reading is intended to provide you, and the maintenance or service technician, with the information needed to install, start up, clean, maintain, and service this ice system.

This is a modular ice system that fits a variety of Scotsman ice storage bins.

Its features include: front service for the freezer, gearmotor, control box, water reservoir, and bin control; an electronic control (AutoSentry™) for monitoring ice level, water level and drive motor current; a thermostatic expansion valve; and R-404A as the refrigerant.

Table of Contents

FOR THE INSTALLER	Page 2
SAMPLE BIN AND MACHINE COMBINATIONS	Page 3
FOR THE INSTALLER	Page 4
FOR THE INSTALLER: Location	Page 5
FOR THE PLUMBER	Page 6
FOR THE ELECTRICIAN	Page 7
FOR THE INSTALLER	Page 8
INITIAL START UP	Page 9
COMPONENT DESCRIPTION	Page 10
COMPONENT DESCRIPTION	Page 11
CONTROL BOX COMPONENTS	Page 12
ELECTRICAL SEQUENCE:	Page 13
OPERATION: Water	Page 14
OPERATION: Refrigeration	Page 15
OPERATION: Performance	Page 16
CLEANING & SANITIZING	Page 17
SENSOR MAINTENANCE	Page 18
AIR COOLED MAINTENANCE	Page 19
BEARING MAINTENANCE	Page 20
AUGER MAINTENANCE	Page 21
SERVICE DIAGNOSIS	Page 22
SERVICE DIAGNOSIS	Page 23
CONTROL SYSTEM DIAGNOSTICS	Page 24
REMOVAL AND REPLACEMENT: Bin Controls	Page 25
REMOVAL AND REPLACEMENT: Bearing And Breaker	Page 26
REMOVAL AND REPLACEMENT: Auger	Page 27
REMOVAL AND REPLACEMENT: Water Seal	Page 28
REMOVAL AND REPLACEMENT: Evaporator	Page 29
REMOVAL AND REPLACEMENT: Gear Reducer and Motor	Page 30
REFRIGERATION SYSTEM SERVICE	Page 31
WHAT TO DO BEFORE CALLING FOR SERVICE	Page 32

Note this symbol when it appears.



NME454, 654 & FME504, 804 FOR THE INSTALLER

These machines fit the following Scotsman products, check sales literature for other possible combinations:

- SB480 and extensions (with bin top KBT18)
- B530 using bin top KBT14 or KBT20
- B842 using bin top KBT28
- B948 using bin top KBT24

NME654 Dispenser Applications

The NME654 can be placed on and used with certain ice and ice-beverage dispensers. Kits are required for proper operation, see the following list:

- ID150, use adapter KBT42 and KNUGDIV
- ID200 or ID250, use adapter KBT46 and KDIL-N-ID2
- Cornelius ED/DF200 beverage dispensers, use KBT46 and KDIL-N-200
- Cornelius ED/DF250 beverage dispensers, use KBT46 and KDIL-N-250
- Lancer nugget ice & beverage dispenser, use KDIL-N-L and Lancer kit #82-3491.

Installation Limitations:

This ice system is designed to be installed indoors, in a controlled environment:

	Min.	Max.
Air Temperature	50°F	100°F
Water Temperature	40°F	100°F
Water Pressure	20 PSI	80 PSI
Voltage (for 115v model)	104	126

(Compared to the nameplate)

Operating the machine outside of the limitations is misuse and can void the warranty.

SPECIFICATIONS: ICE MACHINE

Model Number	Model Series	Dimensions	Basic Electrical	Ice Type	Condenser Type	Minimum Circuit Ampacity	Max. Fuse Size	Refrigerant Charge: R-404A
FME504AS-1	A	27" x 21" x 24"	115/60/1	Flake	Air	15.75	20	22 ounces
FME504WS-1	A	same	same	Flake	Water	14.35	20	18 ounces
FME804AS-1	A or B	same	same	Flake	Air	19.5	30	24 ounces
FME804WS-1	A	same	same	same	Water	18.3	30	20 ounces
FME804WS-1	B	same	same	same	Water	18.3	30	19 ounces
FME804AS-6	A or B	same	230/50/1	same	Air	10.1	15	24 ounces
FME804WS-6	A	same	same	same	Water	9.5	15	20 ounces
FME804WS-6	B	same	same	same	Water	9.5	15	19 ounces
FME804AS-32	B	same	208-230/60/1	Flake	Air	10.2	15	20 ounces
FME804WS-32	B	same	same	Flake	Water	10.2	15	19 ounces
NME454AS-1	A	same	115/60/1	Nugget	Air	15.75	20	22 ounces
NME454WS-1	A	same	115/60/1	same	Water	14.35	20	18 ounces
NME654AS-1	A or B	same	same	same	Air	19.5	30	24 ounces
NME654WS-1	A	same	same	same	Water	18.3	30	20 ounces
NME654WS-1	B	same	same	same	Water	18.3	30	19 ounces
NME654AS-6	A or B	same	230/50/1	same	Air	10.1	15	24 ounces
NME654WS-6	A	same	same	same	Water	9.5	15	20 ounces
NME654WS-6	B	same	same	same	Water	9.5	15	20 ounces

Note: Minimum Circuit Ampacity is used to determine wire size and type per national electric code.

NME454, 654 & FME504, 804

SAMPLE BIN AND MACHINE COMBINATIONS

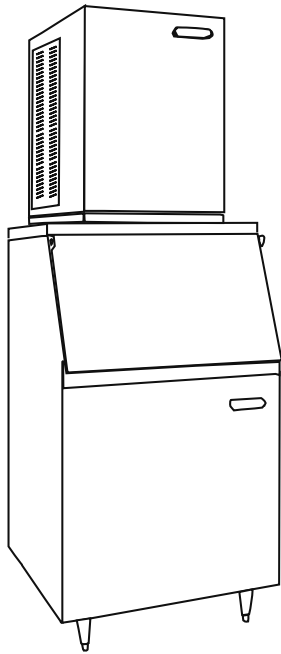

FME804 ON BH550*

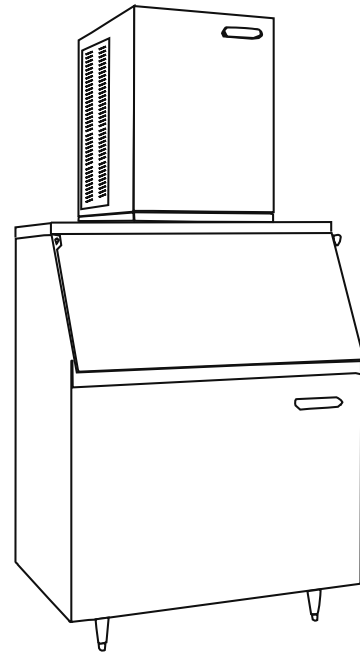

NME654 ON BH801*

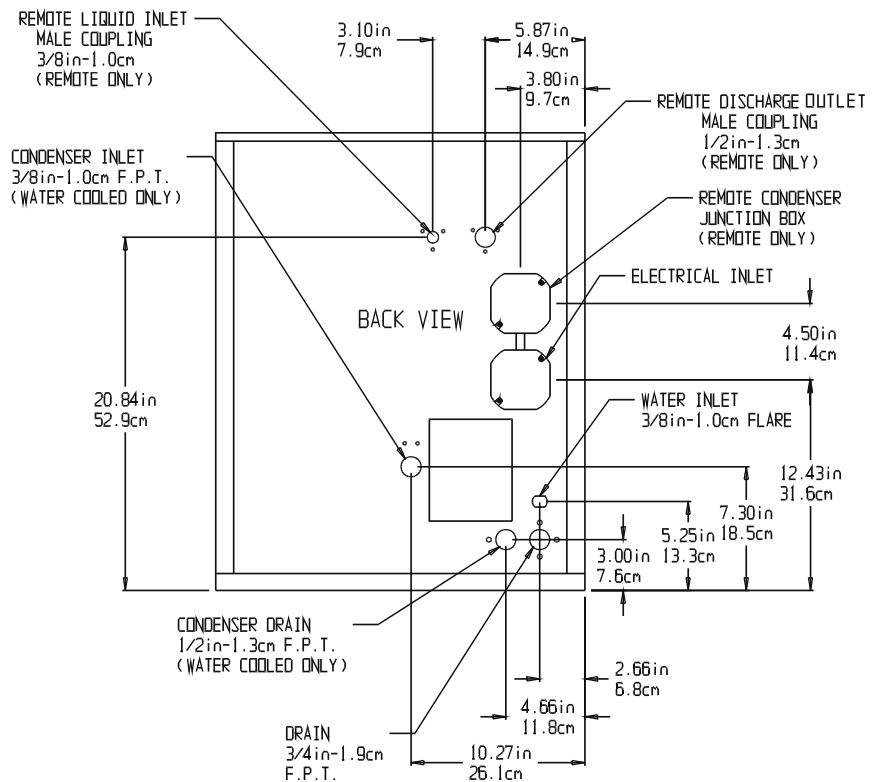

The Nameplate is located on the back of the machine.

A Serial Number Plate is located inside the cabinet, behind the front panel.

*Bin Top Kit Required

NME454, 654 & FME504, 804 FOR THE INSTALLER

Location:

Install the machine be installed in a location where it has enough space around it to be accessible for service. A minimum of 6" must be allowed at the back and sides for air circulation on air cooled models. Try to avoid hot, dirty and crowded locations. Be sure that the location for the machine is within the environmental limitations.

Storage Bin:

Tip the storage bin on its back, using parts of the carton to protect the exterior finish. Install the legs into the threaded holes in the bottom of the bin. Turn the leg levelers all the way in preparation for leveling later. Return the bin to the upright position, remove paper covering the bin gasket.

Note: Do not push bin into position, but lift it there. Pushing a bin, especially one with ice in it, can cause damage to the legs and the leg mounts.

Install the appropriate bin top on the bin, according to the instructions for the bin top.

Ice Machine:

The machine is heavy, so the use of a mechanical lift is recommended for lifting the machine high enough to install on top of the bin. After the unit is placed on the bin, line it up so it is even with the back side. Secure the machine to the bin with the hardware provided with the machine.

Remove the front panel and remove any shipping blocks.

Note: When placing 2 of these machines on a BH801 without the bin top, removal of the 2 service panels facing each other will make future service easier:

1. Remove the 2 top panel screws that will face each other.
2. Remove the 2 service panels that will face each other.
3. Add a strip of gasket, such as Scotsman part number 19-0503-04, to the 2 base edges that will face each other and around service panel space on the 2 panels that will face each other.

When the 2 machines are placed on the bin, the gaskets will seal the bin top area and the space between the machines.

Water Limitations:

An ice machine is a food manufacturing plant: it takes a raw material, water, and transforms it into a food product, ice. The purity of the water is very important in obtaining pure ice and in maximizing product life. This section is not intended as a complete resource for water related questions, but it does offer these general recommendations:

1. Check with a water treatment specialist for a water test, and recommendations regarding filters and treatment.
2. In most cases, the water used to make ice should be filtered or treated, depending upon the water. *There is no one type of water filter that is effective in all situations.* That is why a water test is important.

RO Water Limitation: Water conductivity must be no less than 35 microSiemens/cm.

Note:

Scotsman Ice Systems are designed and manufactured with the highest regard for safety and performance. They meet or exceed the standards of UL, NSF, and CUL.

Scotsman assumes no liability or responsibility of any kind for products manufactured by Scotsman that have been altered in any way, including the use of any part and/or other components not specifically approved by Scotsman.

Scotsman reserves the right to make design changes and/or improvements at any time. Specifications and design are subject to change without notice.

NME454, 654 & FME504, 804

FOR THE INSTALLER: Location

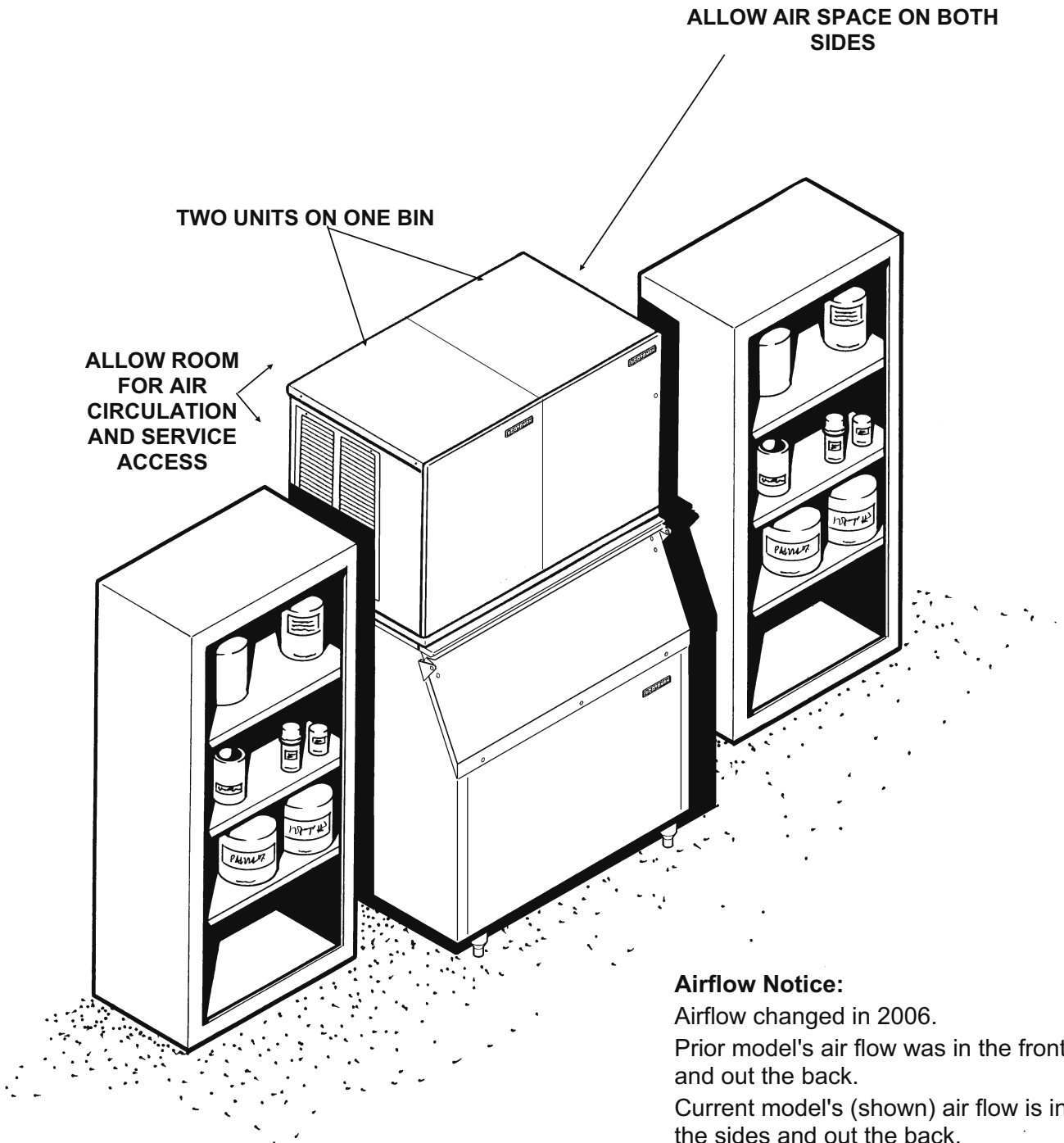

Airflow Notice:

Airflow changed in 2006.

Prior model's air flow was in the front and out the back.

Current model's (shown) air flow is in the sides and out the back.

NME454, 654 & FME504, 804 FOR THE PLUMBER

CONFORM TO ALL APPLICABLE CODES

Water Inlet

Air Cooled Models: Use $\frac{3}{8}$ " O.D. copper tubing to connect cold potable water to the $\frac{3}{8}$ " male flare fitting at the back of the cabinet. Install a hand valve near the machine to control the water supply.

Water Treatment: In most areas, a water filter of some type will be useful. In areas where the water is highly concentrated with minerals the water should be tested by a water treatment specialist, and the recommendations of the specialist regarding filtration and/or treatment should be followed.

Water Cooled Models: Connect a separate $\frac{3}{8}$ " O.D. copper line, with a separate hand valve, to the $\frac{3}{8}$ " FPT condenser inlet at the back of the cabinet. The water pressure to all lines must always be above 20 PSIG, and below 80 PSIG.

Drains

Air Cooled Models: Connect a drain tube to the $\frac{3}{4}$ " FPT drain at the back of the cabinet, the drain line is of the gravity type, and $\frac{1}{4}$ inch per foot fall is an acceptable pitch for the drain tubing. There should be a vent at the highest point of the drain line, and the ideal drain receptacle would be a trapped and vented floor drain.

Use only $\frac{3}{4}$ " rigid tubing.

Water Cooled Models: In addition to the above mentioned drain, a separate condenser drain must be installed. Connect it to the $\frac{1}{2}$ " condenser drain connection at the back of the cabinet.

Storage Bin: Install a separate gravity type drain, similar to the air cooled drain. Insulation of this drain line is recommended.

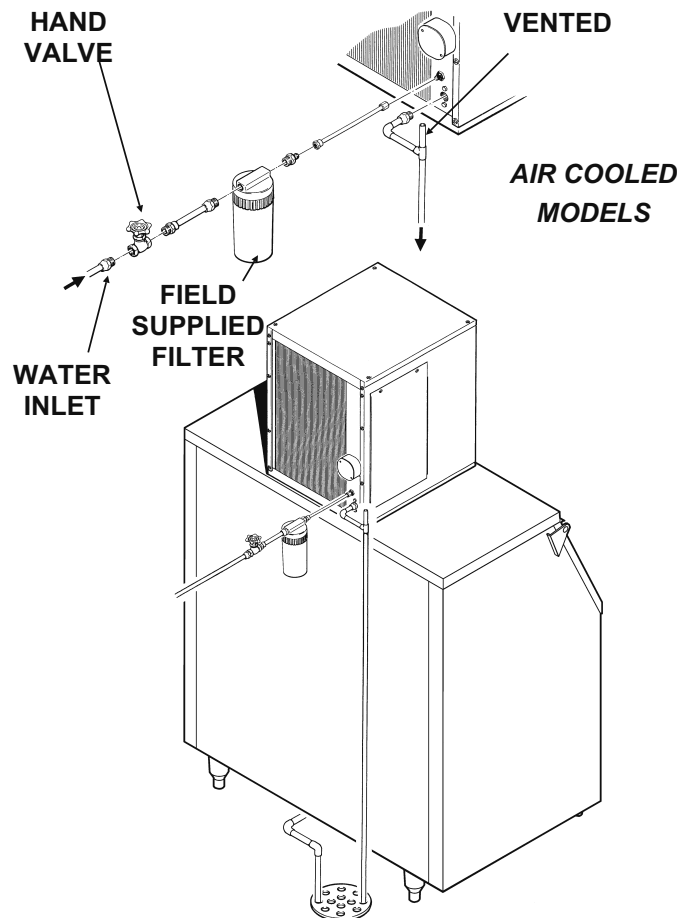
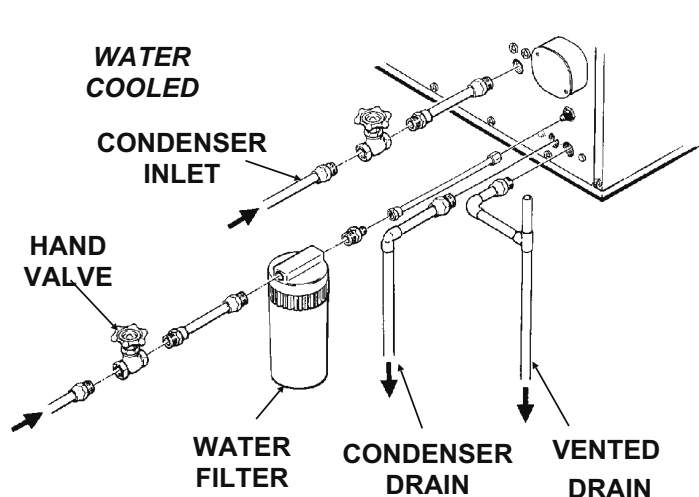

FOR THE ELECTRICIAN

CONFORM TO ALL APPLICABLE CODES

Connect the electrical power to the machine to the wires in the junction box at the rear of the machine. Check the nameplate (located on the back panel) for the voltage requirements, and for the minimum circuit ampacity. The machine requires a solid chassis to earth ground wire.

The ice machine should be connected to its own electrical circuit so it would be individually fused. Voltage variation must remain within design limitations, even under starting conditions.

All external wiring must conform to national, state, and local electrical codes. The use of a licensed electrician is required to perform the electrical installation.

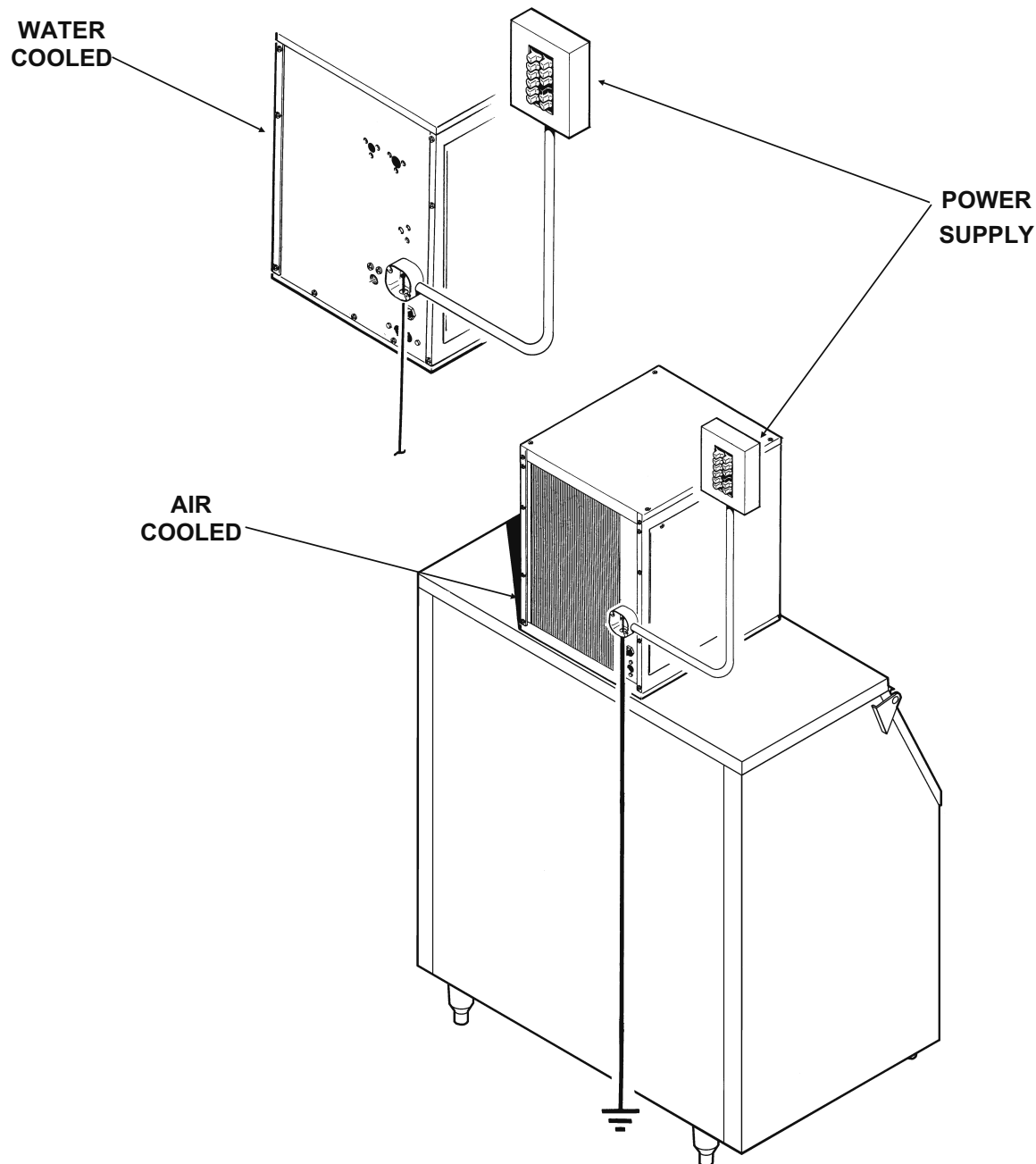

NME454, 654 & FME504, 804 FOR THE INSTALLER

Final Check List

1. Is the ice system installed indoors in a location where the air and water temperatures are controlled, and where they do not exceed the design limitations?
2. Is there an electrical service disconnect within sight of the installed machine? Has the voltage been checked, and compared to nameplate requirements?
3. Have all the plumbing connections been made and checked for leaks?
4. Has the machine and bin been leveled?
5. Is there a minimum of 6" clearance at the back of the machine for proper service access and air circulation?
6. Is the water pressure a minimum of 20 PSIG?
7. Has the machine been secured to the bin?
8. Is there clearance over the top of the machine for service access?
9. Is there a water shut off valve installed near the machine?
10. Have all of the shipping blocks been removed?

INITIAL START UP

Pre-Start Inspection

1. Remove the front and side service panels. are rubbing each other. Check that the fan blade turns freely (air cooled).
2. Check that any shipping blocks have been removed.
3. Inspect the interior of the machine for loose screws or wires. Check that no refrigerant lines
4. Check that the unit is installed correctly according to the final check list (page 8).

Start Up

1. Go through the prestart inspection.
 2. Open the hand valve, observe that water enters the water reservoir, fills the tube from the reservoir to the evaporator, and then shuts off. Check for leaks.
 3. Switch the master switch on. There will be a short delay before the gearmotor and compressor will start.
 4. On air cooled models, the condenser will begin to discharge warm air, on water cooled models, the water regulating valve will open, and warm water will be discharged into the drain.
 5. The unit should soon be making ice, if desired, the low side pressure can be checked: it should be 34 PSIG + or - 4 PSIG.
The suction line temperature at the compressor is normally very cold, nearly to the point of frost up to the compressor body, but not on it.
 6. **THERE ARE NO ADJUSTMENTS TO MAKE**, so replace the panels.
 7. Clean and/or sanitize the storage bin interior, wipe off the exterior with a clean, damp cloth.
 8. Give the owner/user the service manual, instruct him/her in the operation of the unit, and make sure they know who to call for service.
 9. Fill out the manufacturer's registration and mail it to Scotsman.
- The air cooled discharge pressure will depend upon air and water temperatures, but should be between 220 PSIG and 300 PSIG.
 - The water cooled discharge pressure should be constant at about 245 PSIG.
- The above numbers are for new, clean machines, you can expect to see some values higher, and some lower between different units.

NME454, 654 & FME504, 804

COMPONENT DESCRIPTION

Control Box: Contains the electrical controls that operate the machine.

High Pressure Cut Out Switch: An automatic reset switch sensing the high side refrigeration pressure. It is set to shut the machine off if the discharge pressure should ever exceed 450 PSIG.

Low Pressure Cut Out Switch

An automatic reset control that shuts off the ice machine when the low side pressure drops below a preset point, 15 PSIG.

Compressor: The refrigerant vapor pump.

Reservoir: Float operated, it maintains the water level in the evaporator at a constant level, it also contains the water level sensor.

Water Level Sensor: Senses if there is water in the reservoir to make ice out of. Will shut the machine off if there is no water.

Ice Discharge Chute:

Directs the ice produced by the evaporator into the storage bin.

Ice Level Sensor: An electronic "eye", it senses the presence of ice in the bottom of the ice discharge chute. Operates to turn the ice machine on and off

automatically as the level of ice in the bin changes.

Gear Motor: An oil filled, speed reduction gearbox, driving the auger.

Condenser: Air or water cooled, where the heat removed in ice making is discharged.

Expansion valve: The refrigerant metering device.

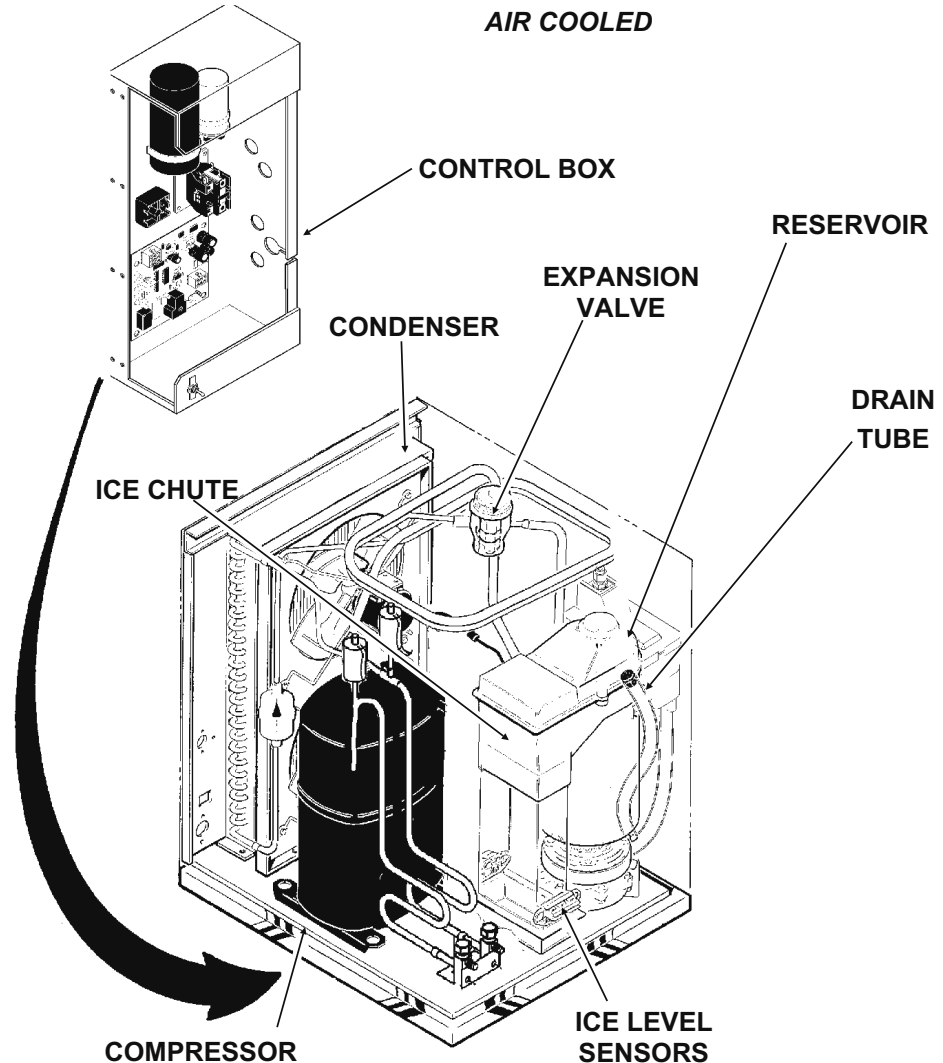

COMPONENT DESCRIPTION

Evaporator: A refrigerated vertical tube filled with water and containing a water seal and auger.

Auger: A solid stainless steel double spiral auger, it pushes the ice crystals up to the top of the evaporator.

Water Seal: A two part "face" seal, the top half rotating with the auger, the bottom half stationary, the sealing action being where the two seal "faces" meet.

Ice Sweep: A plastic cap with "fingers". It revolves with the auger to "sweep" the ice into the ice chute.

Breaker: Where the ice is compressed and much of the extra water is squeezed out of it before it is discharged into the bin.

Motor: The motor that drives the gear reducer and auger.

Thrust Bearing: As the ice is pushed up the evaporator, the auger is thrust down, and pressure from the auger thrust is taken up by this bearing.

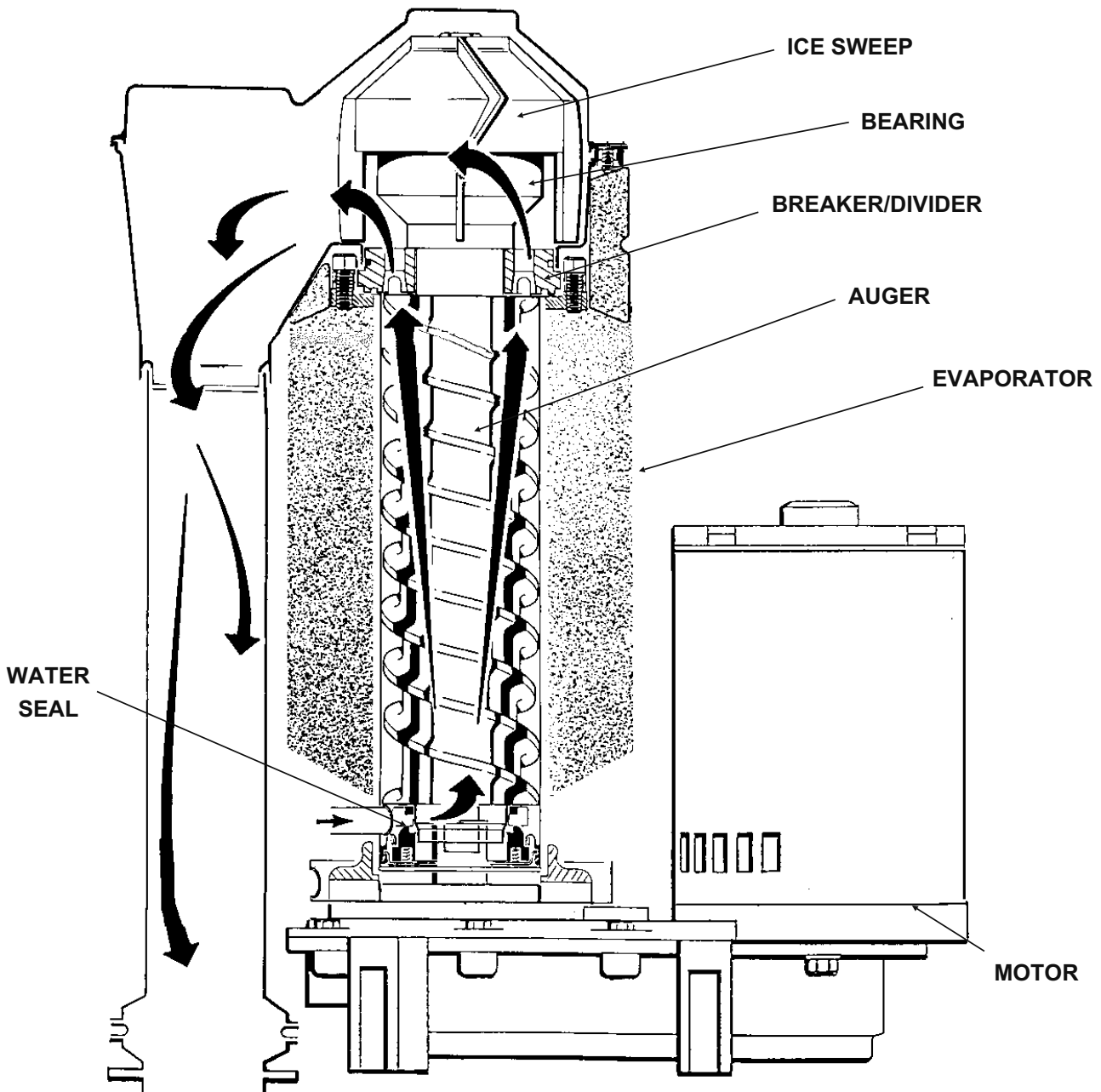

NME454, 654 & FME504, 804 CONTROL BOX COMPONENTS

Contactor: A definite purpose contactor connecting the compressor to the power supply.

AutoSentry™ Control Board

The control board receives input signals from several sensors and translates them to control the electrical power supply to the various loads.

The sensors include:

- Electric eyes to check the ice level in the bin.
- Conductivity probe to determine if there is water in the reservoir.
- Current meter to measure the amp draw of the auger drive motor.

The loads include:

- Compressor contactor
- Auger drive motor

The control board also includes several indicator lights.

Potential Relay: The compressor start relay.

On/Off (mode) Switch: Manual control for the machine.

Control Board

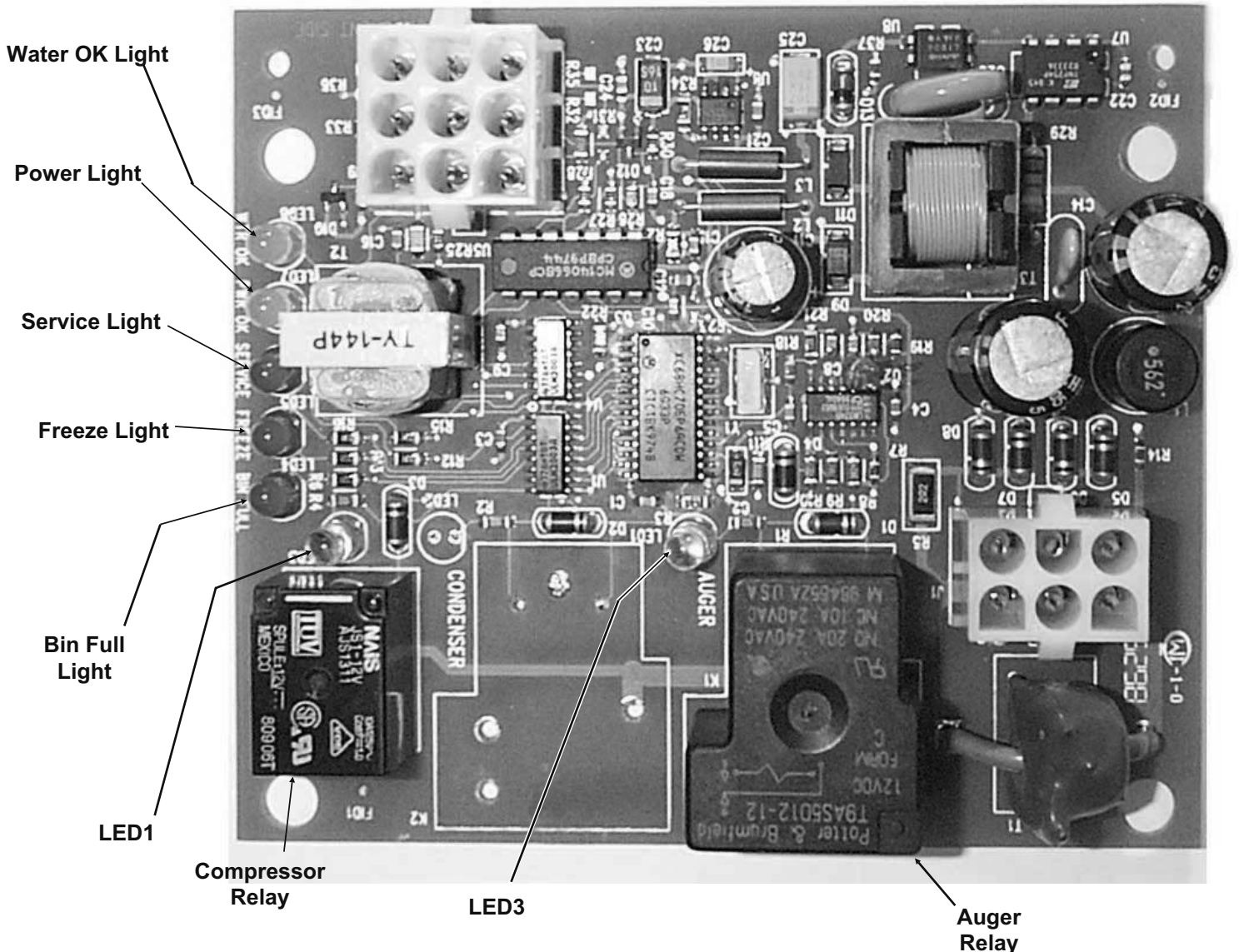

ELECTRICAL SEQUENCE:

There are 7 indicator lights on the control board:

- **WTR-OK** (Water OK). *Green*. **Normal = Glowing. Glows when there is water in the reservoir.**
- **PWR-OK** (Power OK). *Green*. **Normal = Glowing. Glows when the control board has power and is functional.**
- **Service**. *Red*. Normally Off.
- **Freeze**. *Red*. Normally glowing when making ice.
- **Bin Full**. *Red*. Normally Off when making ice.
- **LED1**. *White*. Located next to the board's Compressor Relay. Normally Glowing when making ice.
- **LED3**. *White*. Located next to the board's Auger Motor Relay. Normally Glowing when making ice.

If the machine is switched off at the mode switch, but is otherwise ready to go, switching the mode switch to ON does the following:

- The PWR-OK light glows.
- If there is water in the reservoir the WTR-OK light glows.
- After 10 seconds the Freeze, LED1 and LED3 lights glow and the machine starts up.

Start Up:

- The compressor relay and auger motor relay become energized, connecting power to the windings of the auger motor and contactor coil.
- The contactor is energized, connecting power to the compressor, and the compressor starts.
- As ice is made it passes between the ice level sensors but because it is not a continuous stream it only interrupts the sensor's infrared beam momentarily. The bin full light remains off and the machine stays on until ice builds up in the bin and blocks the path between the sensors for 6 seconds or longer. When that occurs the bin full light glows and the machine shuts down.

Shut Down:

- The compressor relay opens, LED1 goes out.
- The compressor contactor opens
- The compressor stops
- The auger motor stays on for 1 more minute, clearing out ice in the evaporator, and then
- The auger motor relay opens, LED3 goes out and the auger motor stops.

The compressor will not restart until 2 minutes or more have passed after the last shut down.

If the path between the ice level sensors remains clear for more than 10 seconds the ice machine will restart.

Control Board Protection Devices

- When the water level in the reservoir falls below the water level sensor's tip, the WTR-OK light goes out and the machine shuts down. When water refills the reservoir the WTR-OK light glows and the machine starts up again.
- If the auger drive motor current becomes excessive the compressor and auger drive motor will be switched Off and the Service light will blink. The control board will restart the auger drive motor in 4 minutes. If during the first 60 seconds after restart the auger motor current stays within limits, the compressor is restarted and the machine returns to normal operation. If the auger motor's current is excessive within 60 seconds after the restart, the process will be repeated once more. If during that try the current is still excessive the machine shuts down and must be manually reset. The service light will then be glowing continuously.

To Reset: Disconnect and reconnect electrical power to the ice machine.

Other Protection Devices:

- If the **high pressure** cut out switch opens the machine will stop immediately. It will automatically reset when the pressure falls below its cut in point.
- If the **low pressure** cut out switch opens the machine will stop immediately. It will automatically reset when the pressure rises above its cut in point.
- The **mode (on - off)** switch is the manual control for the complete machine, but it is not a service disconnect.

NME454, 654 & FME504, 804

OPERATION: Water

Water enters the machine through the 3/8" male flare at the rear of the cabinet, goes to the water reservoir which it enters through the float valve. The water then goes out the bottom of the reservoir tank to the bottom of the evaporator. Reservoir overflow or evaporator condensation is routed to the drain. Water cooled models have a separate water circuit for the cooling water: it enters the fitting at the rear, goes to the water regulating valve, then to the water cooled condenser and down the drain.

Water Level: The correct water level should be checked when the machine is making ice. Check the water level in the reservoir and compare it to the horizontal line molded into the side of the reservoir. The correct level should be between $\frac{1}{8}$ " above and $\frac{1}{4}$ " below the line. If needed, bend the float arm up or down to adjust the water level.

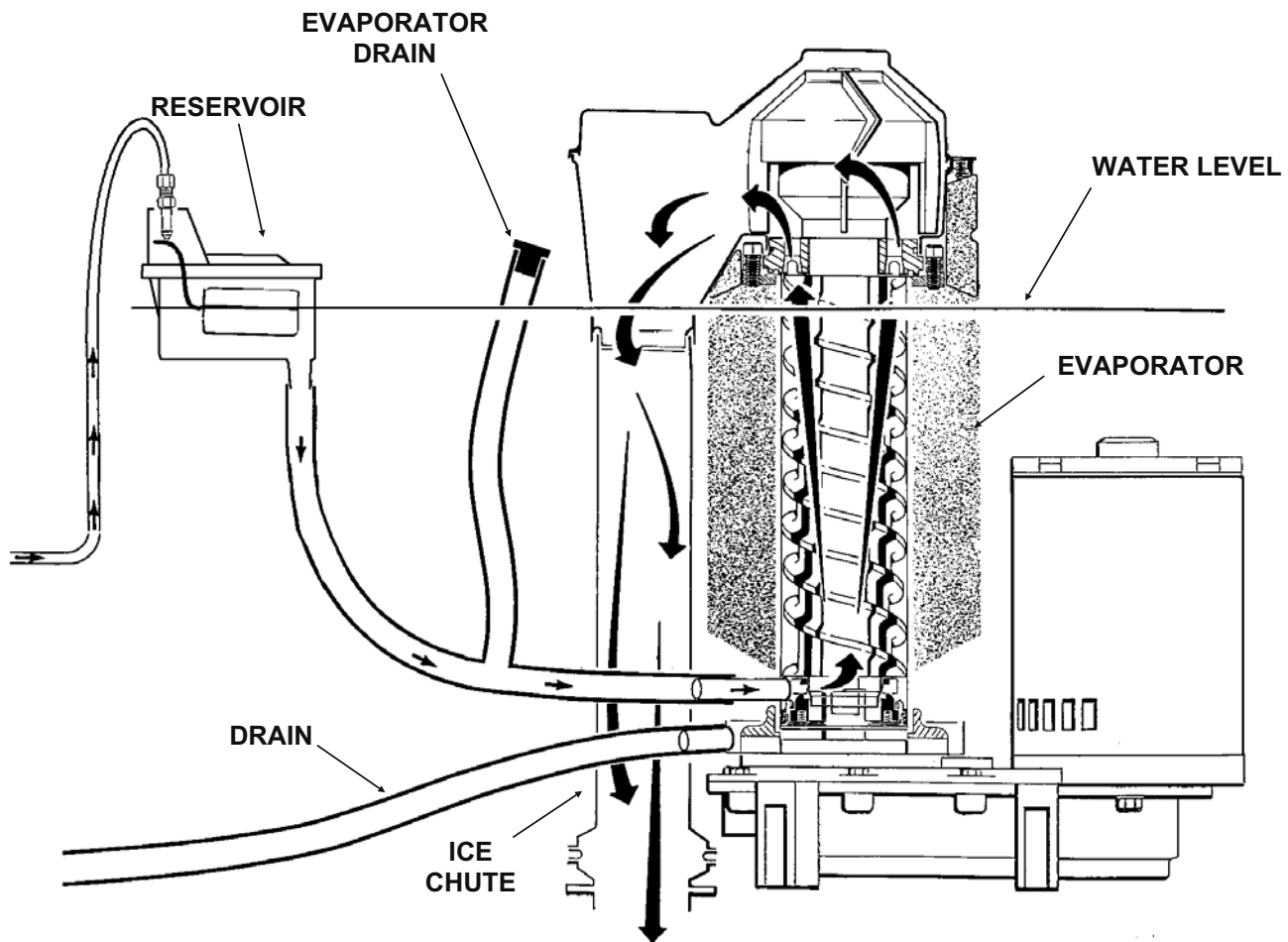

WATER SCHEMATIC

OPERATION: Refrigeration

Beginning at the compressor, the refrigerant is compressed into a high temperature gas. The discharge line directs this gas to the condenser. At the condenser (air or water cooled) the gas is cooled by either air or water and it then condenses into a liquid. This high pressure liquid then goes through the liquid line to the expansion valve. The thermostatic expansion valve meters liquid refrigerant into the evaporator, the volume of liquid refrigerant depending upon the temperature of the evaporator.

At the evaporator, the refrigerant enters an area of relatively low pressure, where it can easily "boil off" or evaporate. As it evaporates, it absorbs heat from the evaporator and whatever is in contact with it (such as the water inside it). After the evaporator, the refrigerant, now a low pressure vapor, goes through the suction line back to compressor, where the cycle is repeated.

Refrigeration Schematic

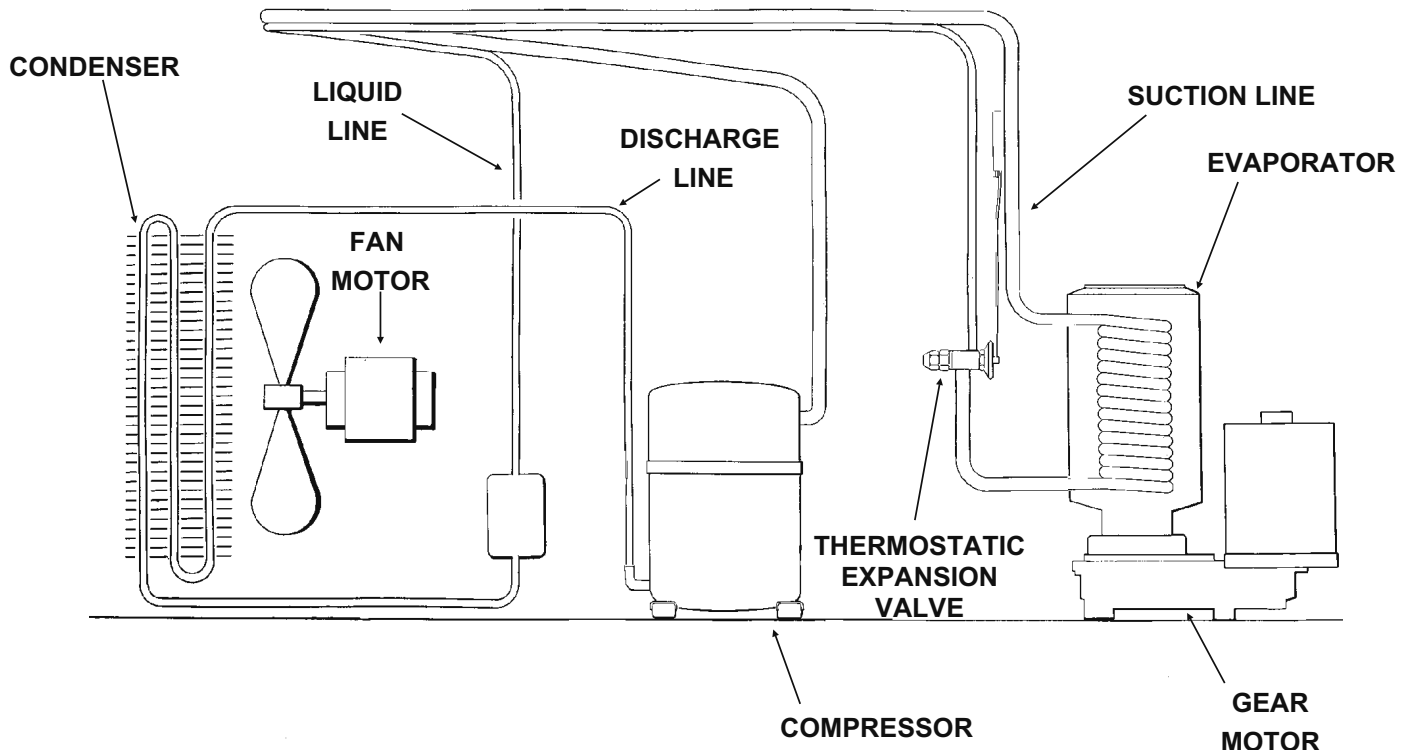

NME454, 654 & FME504, 804

OPERATION: Performance

Typical Low Side Pressure

- Air Cooled: 34 - 38 PSIG
- Water Cooled: 32 PSIG

Typical Discharge Pressure

- Air Cooled: 220 - 300 PSIG
- Water Cooled: 245 PSIG

Typical Compressor Amp Draw

- 8 - 9

Typical Auger Drive Motor Amp Draw (115 volt)

- 3.1 to 3.5 - Emerson
- 4 to 4.5 - GE

Superheat

- 5 - 7 degrees

High Pressure Cut Out - automatic reset

- 450 PSIG

Low Pressure Cut Out - automatic reset

- 15 PSIG

Fan Motor Watts

- 35 Watt

CLEANING & SANITIZING

A Scotsman Ice System represents a sizable investment of time and money in any company's business. In order to receive the best return for that investment, it MUST receive periodic maintenance.

It is the USER'S RESPONSIBILITY to see that the unit is properly maintained. It is always preferable, and less costly in the long run, to avoid possible down time by keeping it clean; adjusting it as needed; and by replacing worn parts before they can cause failure. The following is a list of recommended maintenance that will help keep the machine running with a minimum of problems.

Maintenance and Cleaning should be scheduled at a **minimum of twice per year.**

Note: Electrical power will be ON when doing in place cleaning.

ICE MAKING SYSTEM: In place cleaning

1. Check and clean any water treatment devices, if any are installed.
2. Remove screws and the front and top panels.
3. Move the ON-OFF switch to OFF.
4. Remove all the ice from the storage bin.
5. Remove the cover to the water reservoir and block the float up.
6. Drain the water reservoir and freezer assembly using the drain tube attached to the freezer water inlet. Return the drain tube to its normal upright position and replace the end cap.
7. Prepare the cleaning solution: Mix eight ounces of Scotsman Ice Machine Cleaner with three quarts of hot water. The water should be between 90-115 degrees F.

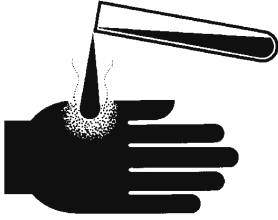
⚠ WARNING	Scotsman Ice Machine Cleaner contains acids. These compounds may cause burns.
	If swallowed, DO NOT induce vomiting. Give large amounts of water or milk. Call Physician immediately. In case of external contact, flush with water. KEEP OUT OF THE REACH OF CHILDREN.

8. Slowly pour the cleaning solution into the water reservoir until it is full. Wait 15 minutes, then switch the master switch to ON.
9. As the ice maker begins to use water from the reservoir, continue to add more cleaning solution to maintain a full reservoir.

10. After all of the cleaning solution has been added to the reservoir, and the reservoir is nearly empty, switch the master switch to OFF.

11. Drain the water reservoir and freezer assembly using the drain tube attached to the freezer water inlet. Return the drain tube to its normal upright position and replace the end cap. Wash and rinse the water reservoir.

Sanitizing:

To sanitize, use an approved sanitizing solution or mix one ounce of household bleach to 2 gallons of warm (95°F.-115°F.) water. Repeat steps 8-11 using the sanitizer solution in place of the cleaning solution.

12. Remove the block from the float in the water reservoir.

13. Switch the master switch to ON

14. Continue ice making for at least 15 minutes, to flush out any cleaning solution.

DO NOT USE any ice produced from the cleaning solution.

Be sure no ice remains in the bin.

15. Remove all ice from the storage bin.

16. Add warm water to the ice storage bin and thoroughly wash and rinse all surfaces within the bin.

17. Sanitize the bin interior with an approved sanitizer using the directions for that sanitizer.

18. Replace the panels.

NME454, 654 & FME504, 804

SENSOR MAINTENANCE

1. The bin control is a device that senses light, therefore it must be kept clean so it can “see”. At least twice a year, remove the bin control sensors from the base of the ice chute, and wipe the inside clean, as illustrated.

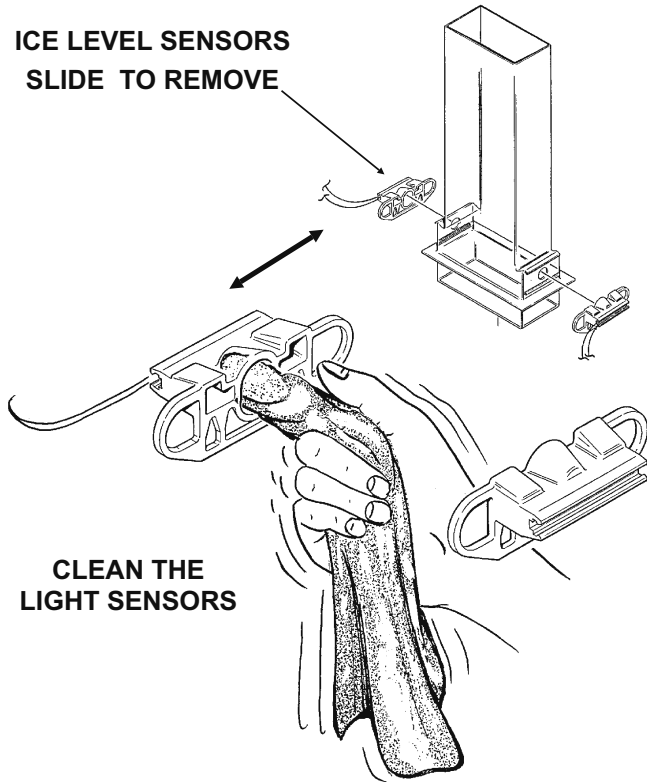

2. The ice machine senses water level by a probe located in the water reservoir. At least twice a year, the probe should be removed from the reservoir, and the tip wiped clean of mineral build-up.

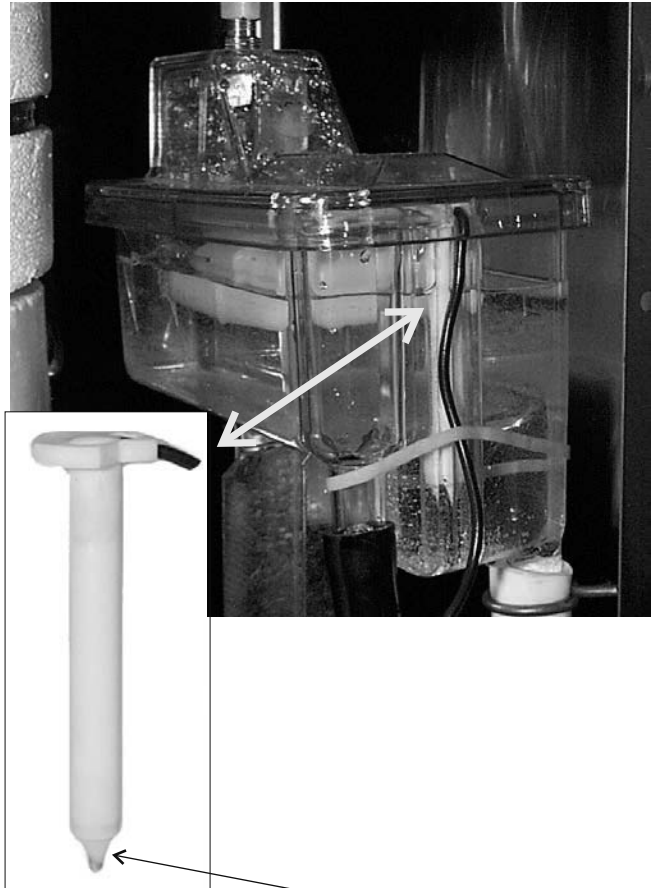

Clean the Probe's Tip with ice machine cleaner and a clean, soft cloth.

AIR COOLED MAINTENANCE

	⚠ WARNING
	Hazardous Moving Parts. Moving fan blade can cause personal injury. Disconnect electrical power before beginning.

Clean the air cooled condenser.

The air flow on this model is from front to back, so the inside of the machine will have to be available to clean the air cooled condenser. Use a vacuum cleaner or coil cleaner if needed. Do NOT use a wire brush.

- A. Disconnect electrical power, and remove the filter. The filter may be cleaned or replaced.
- B. Clean the condenser: the condenser may appear to be clean on the surface, but it can still be clogged internally. Check with a flash light from the front to see if light can be seen through the condenser fins. Reverse to reassemble.

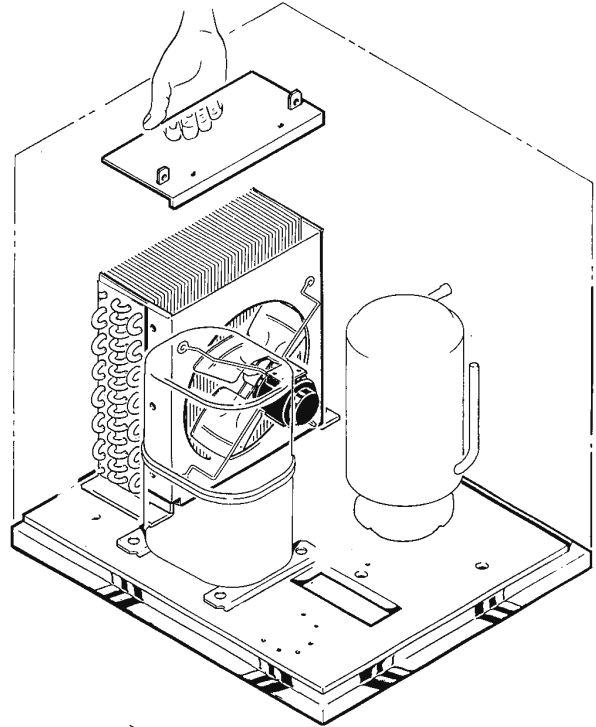

Step 2: Remove the top portion of the fan shroud.

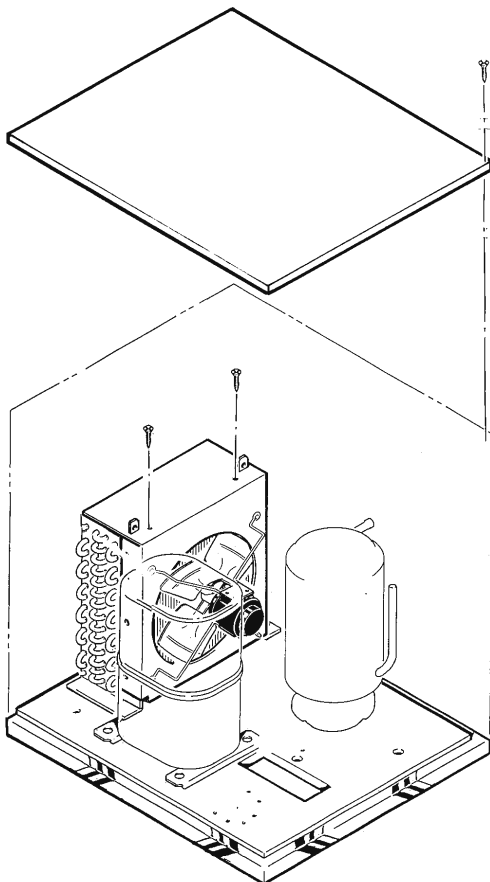

Step 1: Remove the top panel.

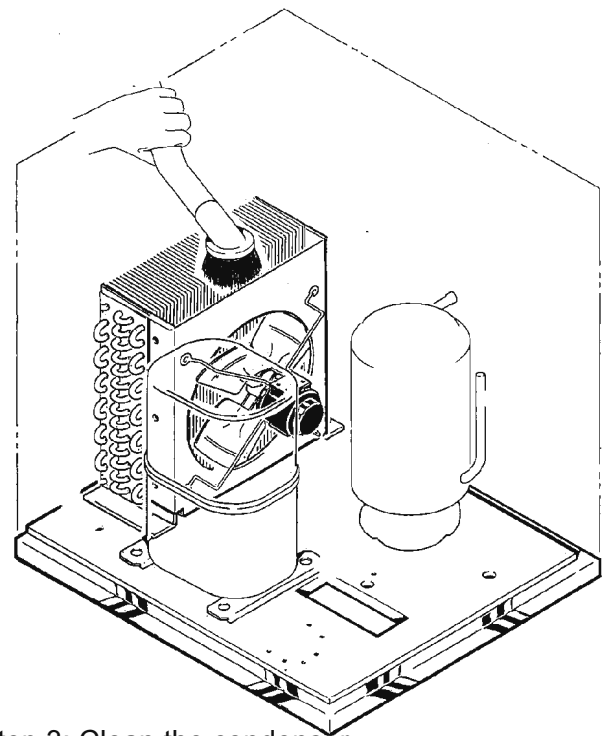

Step 3: Clean the condenser.

NME454, 654 & FME504, 804 BEARING MAINTENANCE

The bearing in the breaker should also be checked at least **two times per year**.

A. Check the bearing by:

- removing the ice chute cover

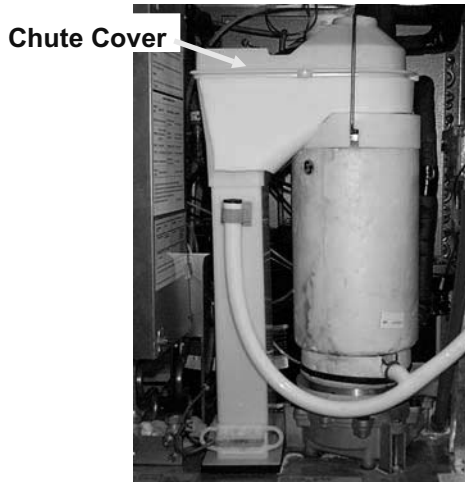

- unscrewing the ice sweep



- removing the water shed & unscrewing the breaker cover (left hand threads).

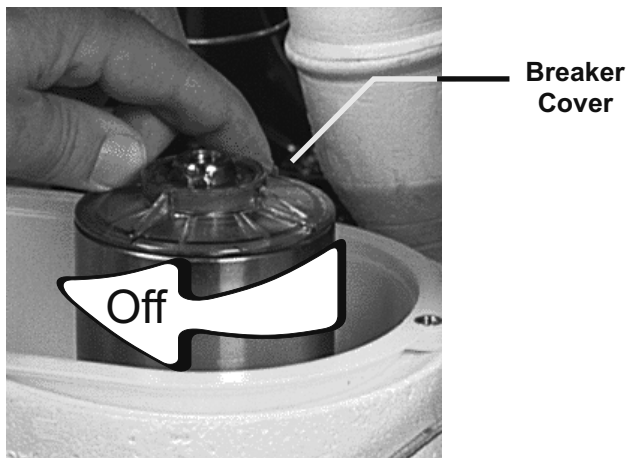

- unscrewing the auger stud

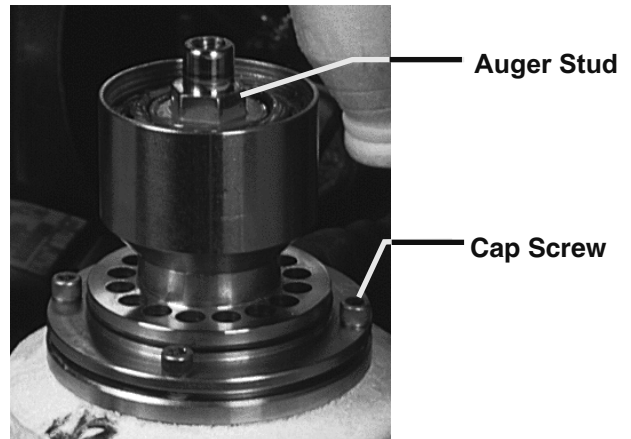

Inspect the bearing. There should be plenty of grease in sight. If grease is needed the bearing and breaker should be removed to check the action of the bearing. It should rotate smoothly.

To remove the breaker remove the lower ice chute then take out all four allen head cap screws and pull the breaker off the auger and evaporator.

If the bearing only needs grease, inject grease into the bearing using Scotsman grease needle pn 02-3559-01 and Scotsman bearing grease cartridge, pn A36808-001. Be sure to inject grease evenly and thoroughly.

See Removal and Replacement section to replace bearing or seals.

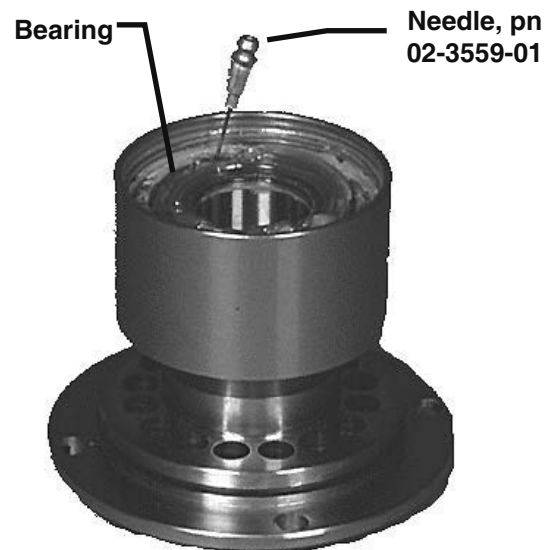

Reverse to reassemble.

AUGER MAINTENANCE

In some areas, the water supply to the ice maker will contain a high concentration of minerals, and that will result in an evaporator and auger becoming coated with these minerals, requiring a more frequent removal than twice per year. If in doubt about the condition of the evaporator and auger, the auger can be removed so the parts can be inspected.

Note: Water filters can filter out suspended solids, but not dissolved solids. "Soft" water may not be the complete answer. Check with a water treatment specialist regarding water treatment.

For more information on removal of these parts, see REMOVAL AND REPLACEMENT.

1. To remove the auger, remove the front and top panels.
2. Push bail clamp back from the top of the chute cover.
3. Unscrew and remove ice sweep.

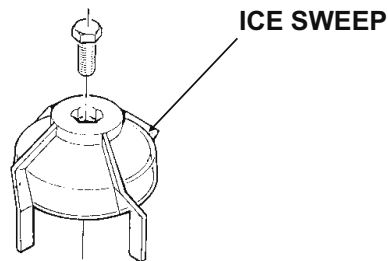

FME Components Shown, NME similar.

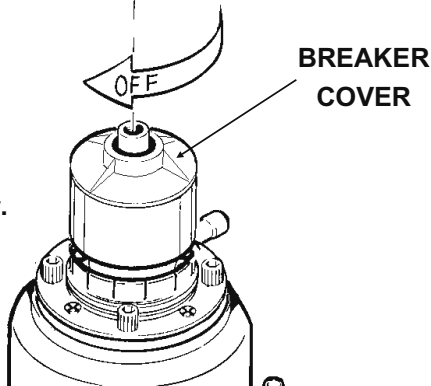

4. Remove 4 allen screws holding breaker to evaporator.

5. Pull up to remove auger.

After the auger has been removed, allow the auger to dry: if the auger is not bright and shiny, it must be cleaned.

Clean the auger and evaporator as required. DO NOT HONE THE EVAPORATOR.

FME Components Shown, NME similar.

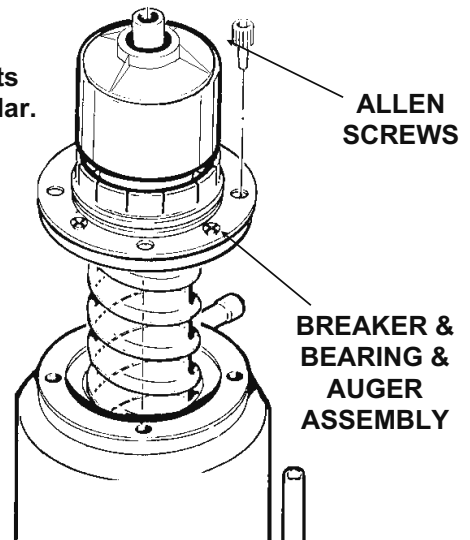

7. Replace the water seal.

8. Reverse to reassemble.

NME454, 654 & FME504, 804

SERVICE DIAGNOSIS

Symptom	Possible Cause	Probable Correction	
No ice is made, nothing operates	Unit off due to no power	Restore Power	
	Unit off due to master switch in OFF position.	Switch master switch to ON.	
	Unit off due to low water level.	Check water supply, filter, strainer, float valve. Correct water supply.	
	Unit off due to ice level sensors (photo-electric eyes) blocked.	Check/clean ice level sensors.	
	Unit off due to scale on water level sensor.	Clean water level sensor.	
	Unit off due to high pressure control open.	Check for water interruption (water cooled) or fan motor failure (air cool).	
	Auger motor hums but does not turn.	Auger can't turn. Circuit board has not yet shut unit down.	
	Unit is shut down	Circuit board has shut ice machine down due to high auger motor amp draw. Check for cause of high amp draw, including bearings, gearmotor condition and scale on auger and in evaporator.	
	Low pressure control open		Auger not turning due to: motor failure; auger relay failure on circuit board; or gears stripped. Check drive train.
			TXV restricted or not metering. Check bulb temperature.
			Lack of refrigerant. Check for leak. Check for a restricted system
	No power to circuit board.		Check harness
			Hi or low pressure cut outs open
	Circuit Board gear motor relay will not close		Check, replace board
Water level or ice level sensor failed.		Check, replace sensor	
No ice, auger motor is turning	Compressor contactor coil is open	Check/replace contactor	
	Compressor will not start	Check start capacitor.	
		Check start relay	
		Check compressor windings	
Circuit board compressor relay will not close.		Check, replace board	
Unit makes ice, but very slowly.	High discharge pressure because of a dirty condenser	Clean the air filter and condenser.	
	Low capacity because the auger and evaporator are coated with mineral scale	Clean the water system	
	Low suction pressure due to low refrigerant charge	Locate leak. Recover refrigerant, repair leak, replace dryer, evacuate and weigh in the nameplate charge	

SERVICE DIAGNOSIS

Symptom	Possible Cause	Probable Correction
Water Leak	Drain plugged up	Clean out drain
	Tubing cracked	Replace tubing
	Condensation on drain tubing	Insulate tubing
	Hose off	Reattach hose
	Reservoir cover off	Return cover to reservoir
	Reservoir cracked	Replace reservoir
	Evaporator water seal leaks	Check base of evaporator & drip pan. If the seal leaks, shut off the water, remove the auger, replace the water seal. Check gear motor for water infiltration.
Excessive water use	Water cooled model, water regulating valve not adjusted properly.	Adjust to 245 PSIG discharge pressure
	Reservoir float valve leaks thru	Replace float valve or seat
	Water cooled model, overcharged with refrigerant	Recover and weigh refrigerant. Weigh in correct charge.
	Water cooled model, condenser coated with minerals	Acid clean water cooled condenser.
Excessive ice meltage	Bin drain clogged	Clean out bin drain.
	Improper installation of drains, they are connected.	Drains must be separate.
	Poor fit between bin door and door frame	Adjust or replace
Machine makes too much noise	Evaporator coated internally with minerals	Clean with Scotsman Ice Machine Cleaner
	Motor bearings dry	Oil or replace motor

NME454, 654 & FME504, 804

CONTROL SYSTEM DIAGNOSTICS

The control system consists of:

- Control Board
- Water Sensor
- Ice Sensors
- High Pressure Cut Out
- Low Pressure Cut Out

If the unit is OFF, check the **control board**:

1. Is the Power OK light on? If not check power to the unit. If it has power, and the Power OK light is NOT on, check the high pressure and low pressure cut outs. If they are both closed, replace the board. If the Power OK light is ON, go to the next step.

2. Is the Water OK light on? If it is, go to the next step. If not, check the water level in the reservoir. If there is water in the reservoir, check that the water sensor is plugged in. To check the **water sensor**:

A. Unplug water sensor.

B. Pull water sensor from reservoir.

C. Place one ohmmeter lead on the sensor's plug and the other on the sensor's tip. The meter should show nearly zero resistance. If it reads infinite resistance, check the tip for corrosion. If it is clean and still reads open, replace the sensor.

OR connect a copper wire to the wire where the water sensor plugs into and place the other end in the water. The water OK light should go ON. If it does not, replace the control board.

3. **Ice sensor check.** Is the Bin Full light Off? If it is OFF and the Service light is Off, and the unit is not running, replace the control board.

If it is OFF and the auger motor is running but the compressor is not, check the compressor contactor coil.

If it is on, the ice sensors may be blocked. Remove them and check for mineral scale. Scotsman's test

box can also be used to determine if the ice sensors or board are defective.

Using the tester:

A. Disconnect the ice sensors at the connection by the ice chute. Connect the LED and PHOTO TRANS wires to the control board's wires.

B. With the On - Off (mode) switch in either position, move the Bin Full switch on the tester to Bin Full - the tester's light will blink and after a few seconds the bin full light on the control board will come on. If not, replace the board.

Move the Bin switch on the tester to Bin Empty. The light on the tester will go out, and after a few seconds the Bin Full light on the board will go out. If master switch is ON, the unit should start.

4. **High pressure** cut out check.

Disconnect electrical power.

Pull the wires off the high pressure cut out.

Use an ohmmeter to determine if the switch is OPEN, If it is, check the discharge pressure. If the discharge pressure is less than 300 PSIG, replace the high pressure cut out.

If the high pressure cut out is open and the system has high discharge pressure, check for the cause.

5. **Low pressure** cut out check.

Disconnect electrical power.

Pull the wires off the low pressure cut out.

Use an ohmmeter to determine if the switch is OPEN, If it is, check the suction pressure. If the suction pressure is greater than 20 PSIG, replace the low pressure cut out.

If the low pressure cut out is open and the system has low suction pressure, check for the cause.

REMOVAL AND REPLACEMENT: Bin Controls

BIN CONTROLS (Ice Level Sensors)

1. Disconnect electrical power.
2. Remove front panel.
3. Remove control box cover.
4. Locate ice chute, at the base of the chute, in front of and behind it are two plastic bin control mounts.
5. Slide each bin control to the left, and in the control box, disconnect the electrical leads connecting the bin control to the circuit board.
6. Reverse to reassemble, be certain that the bin controls are aligned so that the ice level sensors are visible (centered) through the holes in the ice chute.

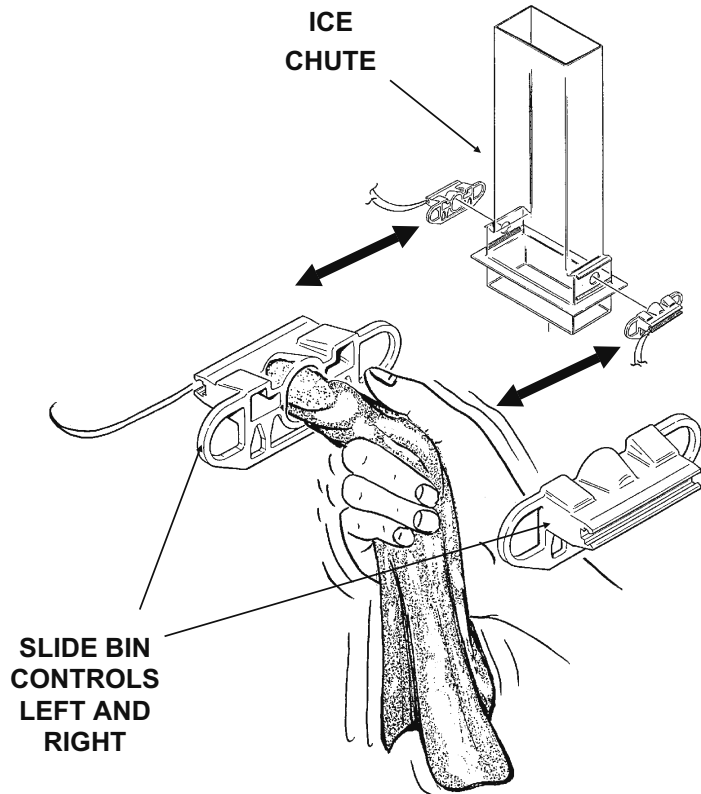

RESERVOIR

1. Shut off water supply.
 2. Remove front panel.
 3. Remove reservoir cover.
 4. Disconnect water inlet tube from reservoir inlet fitting.
 5. To remove float valve, push in on "Locking Tab" as shown and pull valve up.
- Note: The plunger/seat is available as a separate part.
6. To remove reservoir, pull up and remove water sensor.
 7. Disconnect water outlet tubes.
 8. Remove the two screws holding reservoir to bracket.
 9. Remove reservoir from ice machine.
 10. Reverse steps 1-9 to reassemble.

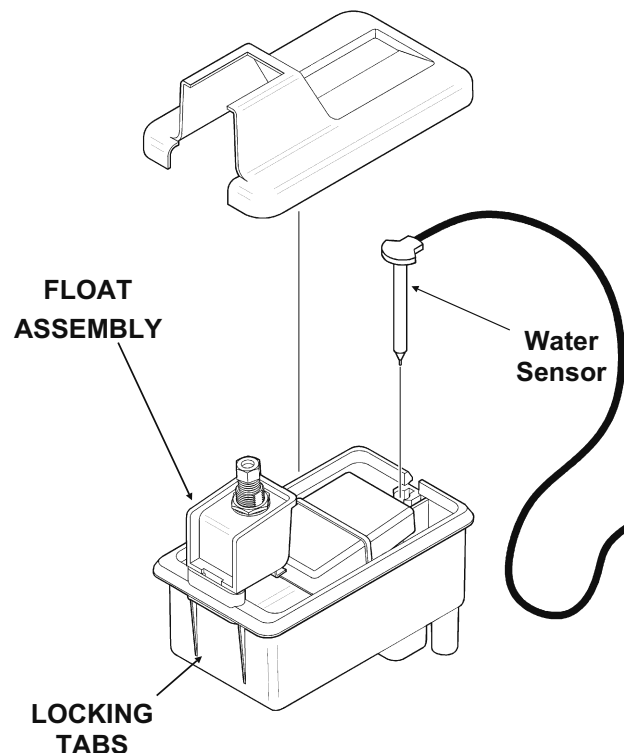

NME454, 654 & FME504, 804

REMOVAL AND REPLACEMENT: Bearing And Breaker

	⚠ WARNING
	Hazardous Moving Parts. Moving auger can cause personal injury. Disconnect electrical power before beginning.

Note: Removal of the auger, water seal, evaporator and gear reducer must begin at the top of the assembly.

To Remove the Breaker Bearing Assembly:

1. Remove panels and disconnect electrical power.
2. Pull the bail clamp off of the chute cover.
3. Unscrew and remove ice sweep.
4. Lift up and remove ice chute.
5. The breaker may be removed from the auger and evaporator without disturbing the auger.
 - a. Unscrew breaker cover from breaker (left hand threads)
 - b. Unscrew auger stud from top of auger.
 - c. Unscrew 4 allen head cap screws holding breaker to evaporator.
 - d. Lift up, and remove breaker/bearing assembly from auger & evaporator.

FME Components Shown, NME similar.

6. Service the bearing. Check for rust, rough spots and damage.

a. The bearing is pressed into the breaker, to remove the bearing and replace it an arbor press is needed.

b. Replace lower seals before installing new bearing in breaker.

Note: seals must be pressed in with a tool pushing against the outer edge only, they will not install by hand.

Replace parts as required. Re-grease bearing with Scotsman part no. A36808-001 bearing grease. Replace top seal, and check the o-rings, replace if cut or torn.

7. Reverse to reassemble: specific tools and materials are required to install properly.

a. Add food grade grease such as Scotsman part number 19-0569-01 to the seal area before installing on the auger.

b. Check the seal to shaft areas for cuts, or rough spots: none are permitted.

Step 5-a

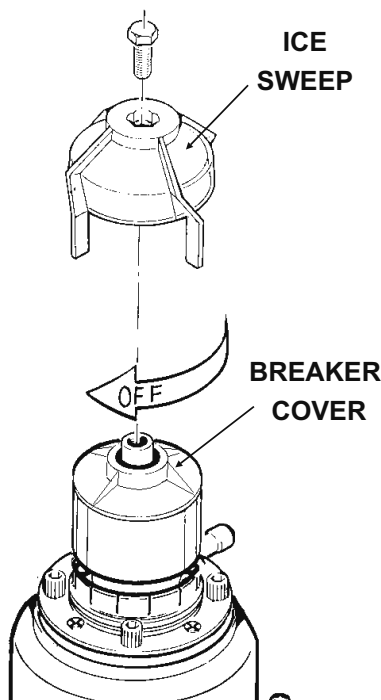

Step 5-b

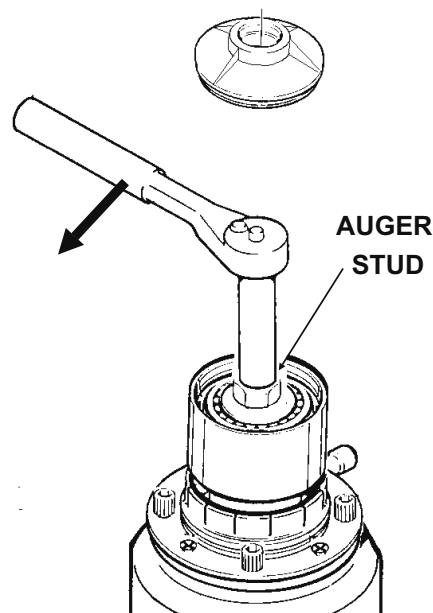

Step 5-c and Step 6

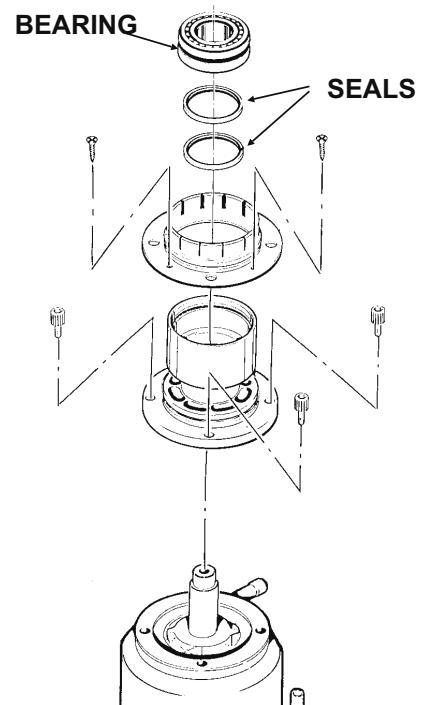

REMOVAL AND REPLACEMENT: Auger

	<h3>⚠ WARNING</h3>
	<p>Hazardous Moving Parts.</p> <p>Moving auger can cause personal injury.</p> <p>Disconnect electrical power before beginning.</p>

To Remove the Auger:

Turn off the water to the machine, and unclip the evaporator drain hose, pull it down and drain the evaporator into the bin or a container.

1. The top panel must be removed.
2. Remove bail clip and remove ice chute cover.
3. Unscrew ice sweep.
4. Remove ice chute body.
5. The auger and breaker/bearing may now be removed as an assembly.

- a. Unscrew 4 allen head cap screws holding breaker to evaporator.

- b. Lift up on breaker and remove auger from evaporator.

Note: If the auger is stuck, the breaker must be removed from the auger.

The breaker may be removed from the auger and evaporator without disturbing the auger.

- a. Unscrew breaker cover from breaker (left hand threads)
- b. Unscrew auger stud from top of auger.
- c. Unscrew 4 allen head cap screws holding breaker to evaporator.
- d. Lift up & remove breaker from evaporator.

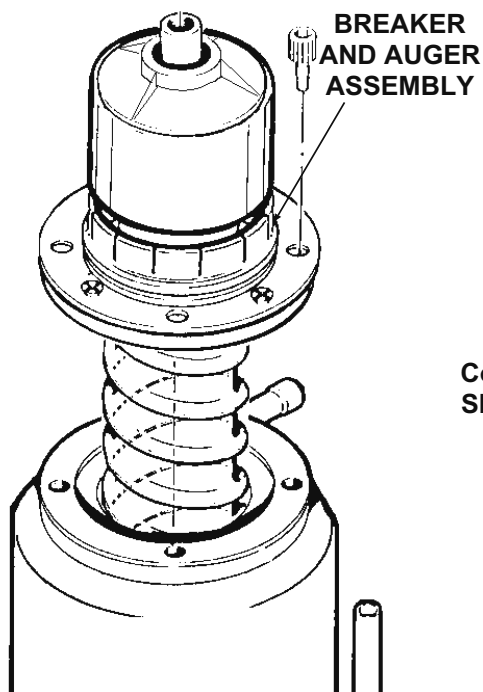

e. If the auger is stuck use a slide hammer type puller to pull on the auger at the threaded hole. The size of that hole is 5/8"-18.

Inspect the auger, the critical areas of the auger are:

1. The auger body. It should be clean and shining. Sometimes an auger will appear clean when wet, but after it is dry it will be seen to be stained. Scrub the auger with ice machine cleaner and hot water.

Ice machine cleaner is an acid. Handle it with extreme care, keep out of the reach of children.

2. The water seal area. Because the auger has been removed, the water seal will have to be replaced. Remove the water seal top half from the auger, and inspect the auger for minerals clean as required.

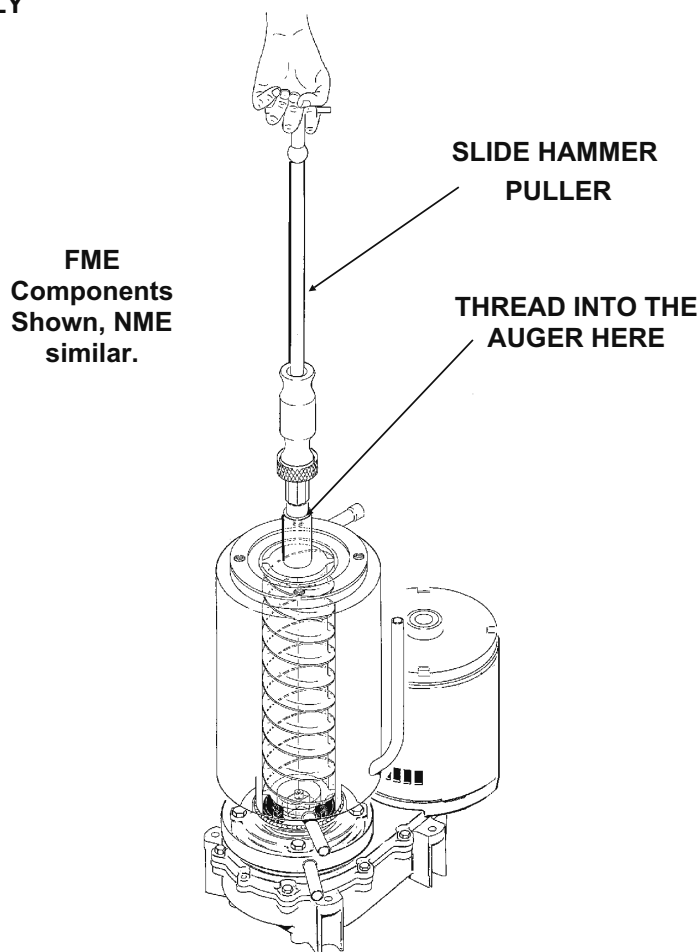

NME454, 654 & FME504, 804

REMOVAL AND REPLACEMENT: Water Seal

To Remove the Water Seal:

(Assuming all steps to remove the auger have been performed.)

1. The gearmotor/evaporator assembly will have to be exposed.
2. Remove the 4 hex head cap screws holding the evaporator to the gearmotor assembly. Lift the evaporator up and off of the gearmotor.
3. Remove the snap ring or wire retainer from the groove under the water seal.
4. Pull or drive out the lower half of the water seal.

REMOVAL OF THE WATER SEAL

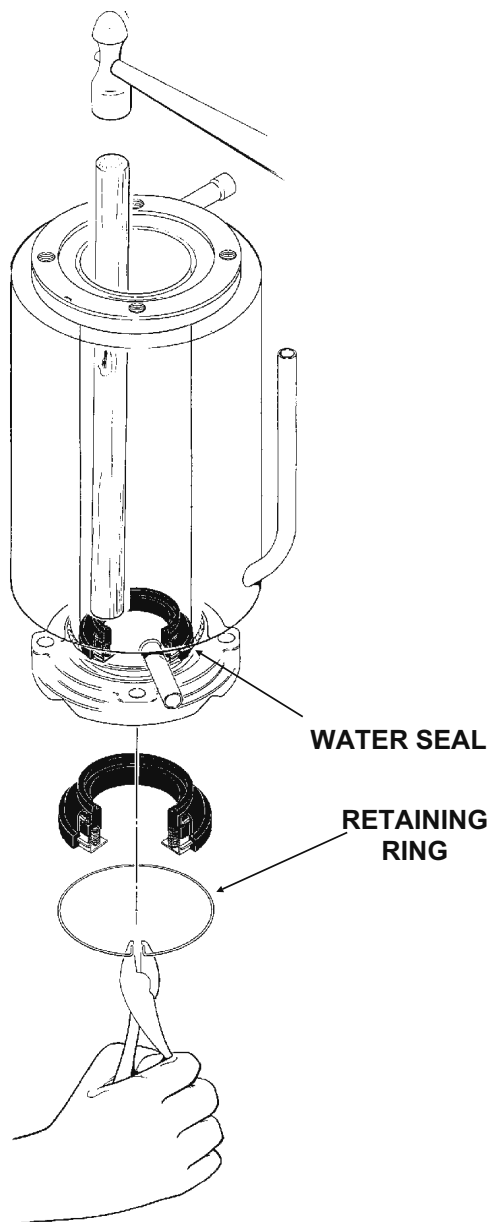

To Replace the Water Seal:

1. Lubricate the water seal with water, and push the water seal into the bottom of the evaporator slightly past the groove for the snap ring.
2. Replace the snap ring and pull the water seal down against it.
3. The part of the water seal that rotates with the auger must also be replaced. Remove the old part from the auger and clean the mounting area.
4. Place a small bead of food grade silastic sealant (such as 732 RTV or Scotsman part number 19-0529-01) on the area of the auger where the water seal is to be mounted.

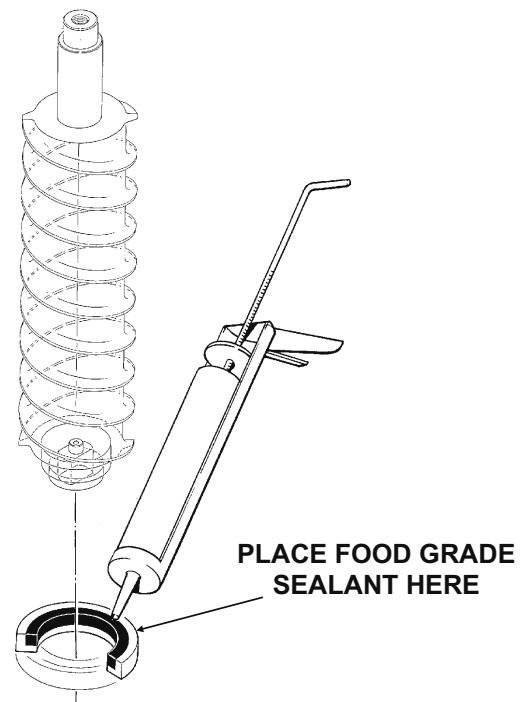

5. Carefully push the water seal (rubber side against the auger shoulder and the silastic.)

Do not get any sealant onto the face of the seal.

6. Allow the auger and seal to air dry until the silastic is dry on the surface.
7. If the original water seal was leaking, it would be a good idea to inspect the interior of the gearmotor.

NME454, 654 & FME504, 804

REMOVAL AND REPLACEMENT: Evaporator

To Replace the Evaporator:

(Assuming all the steps for removal of the thrust bearing, breaker, auger, and water seal have been performed.)

1. Recover the refrigerant from the ice maker.
2. Unswear the refrigerant connections:
 - a) At the thermostatic expansion valve outlet.

Heat sink the TXV body when unswearing or resweating the adjacent tubing.

b) At the suction line at the joint about 3" from the evaporator.

3. Remove the evaporator.
4. Unswear the drier from the liquid line.
5. After installing a new water seal in the new evaporator (see "To Replace the Water Seal") sweat in the new evaporator at the old tubing connections.
6. Install a new drier in the liquid line.
7. Evacuate the system until dehydrated, then weigh in the nameplate charge. Check for leaks.

8. Install auger, breaker, breaker bearing assembly, and ice discharge chute in reverse order of disassembly. See "To Reassemble Evaporator and Auger"

To Reassemble the Evaporator and Auger

1. After the gearmotor has been inspected, fasten the evaporator to the gear motor, be sure that the number of shims indicated on the gear case cover is in place between the gearcase cover and the drip pan gasket. Torque the bolts to 110 inch pounds.
2. Lower the auger into the evaporator barrel, slightly turning it to match up with the drive end. Do Not Drop Into the Evaporator.
3. Complete the reassembly by reversing the disassembly for the breaker & thrust bearing assembly.

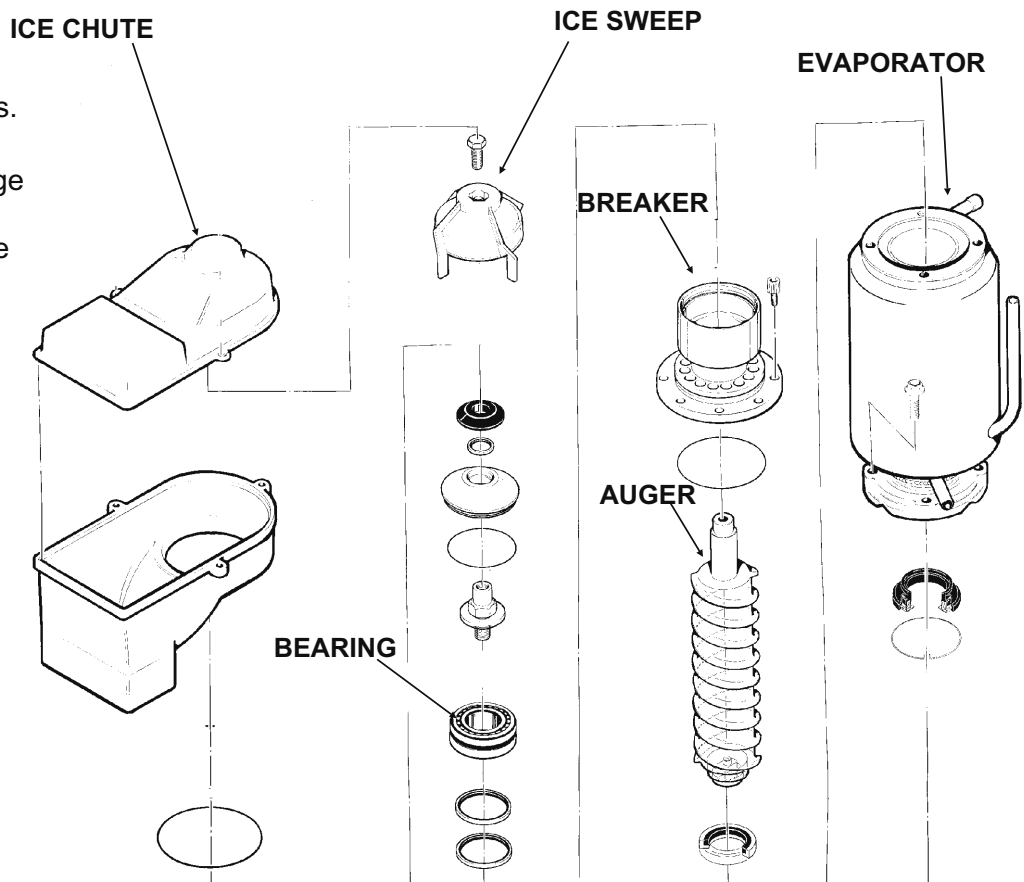

NME Components
Shown, FME similar.

NME454, 654 & FME504, 804

REMOVAL AND REPLACEMENT: Gear Reducer and Motor



⚠ WARNING

Electrical Shock Hazard.
Electrical shock can cause personal injury.
Disconnect electrical power before beginning.

To Check the Motor:

1. Remove wires from terminals 1 and 2.
2. Use an ohmmeter to check for continuity. If there is none, replace the motor only. If there is continuity, but the motor will not start, check the motor's start switch.
3. Remove motor end bell or motor stator. With ohmmeter wires attached to 1 and 2, move centrifugal switch actuator up and down to simulate motor speed. If the ohmmeter does not show any change, replace the switch or motor. If the ohmmeter shows an open circuit, replace the switch or motor.

To Remove and Repair the Gear and Motor Assembly:

(Assuming that the procedures through removal of the water seal have been performed.)

1. Remove the electrical wires from the gear drive motor.
2. Unscrew the 4 cap screws holding the gearmotor to the base of the machine.
3. Remove the gearmotor from the unit.
Bench test the gearmotor, check for oil leaks, noise, and amp draw.

To Inspect the gearmotor.

- A) Remove the cap screws holding the gearmotor case halves together and pry the two cases apart.
- B) To lift off the cover, lift up until you can feel internal contact, then pull the cover towards the output gear end, and then lift the cover (with drive motor attached) up and away from the gear motor case.

Note: The gear case cover, output gear, bearings and output shaft are a pressed together assembly. Replace as a unit.

- C) Inspect the oil, gears, and bearings. If the oil level and condition is acceptable, quickly check the

gears and bearings. They are likely to be fine if the oil is.

If there is evidence of water in the oil (rusty bearings and gears; the oil having a creamy white appearance; oil level too high) carefully inspect the bearings and gears. If in doubt about the condition of a part, replace it. The oil quantity is 14 fluid ounces, do not overfill.

Note: The gears and bearings are available only as pressed together sets.

D) After replacing parts as required, (if any) reassemble the gearcase. The two smaller gears and the oil should be in the lower case, the output gear will be with the cover. As you lower the cover onto the lower case, the cover will have to be moved closer to the

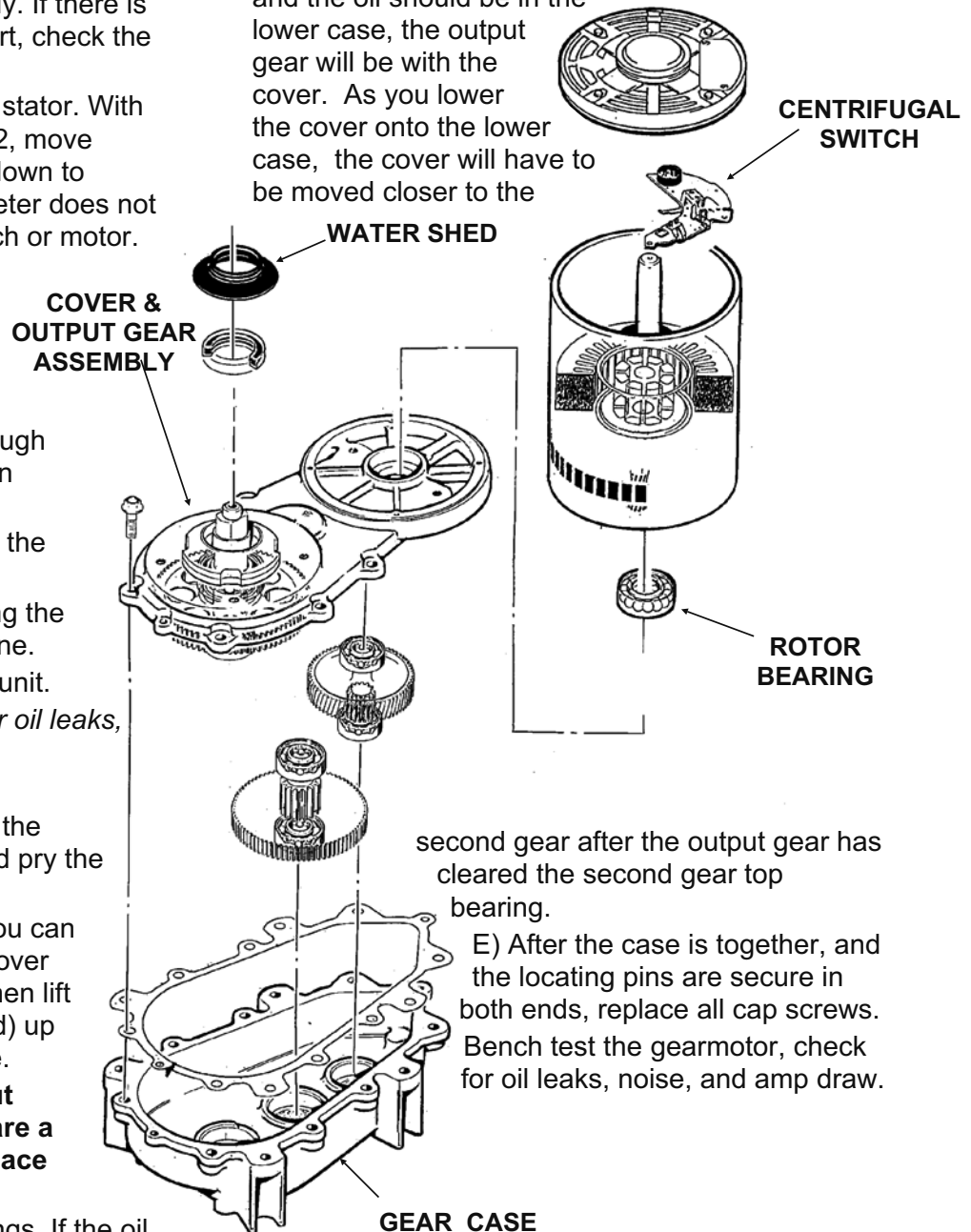

second gear after the output gear has cleared the second gear top bearing.

E) After the case is together, and the locating pins are secure in both ends, replace all cap screws. Bench test the gearmotor, check for oil leaks, noise, and amp draw.

REFRIGERATION SYSTEM SERVICE

General: This ice machine uses R-404A refrigerant and polyolester oil. Do NOT use mineral oil in this refrigeration system.

- When the system is serviced, a special liquid line drier is required. It is included with replacement compressors.
- R-404A is not compatible with mineral oil so these ice machines use Polyolester oil. Polyolester oil absorbs water very easily. A system opened for service must be re-sealed as soon as possible (15 minutes maximum).
- Special leak detection equipment is required to locate small refrigerant leaks. Usually a leak detector capable of detecting a Halogenated refrigerant or HFC-134a will work. Check with the leak detector manufacturer if in doubt.
- Evacuate to 300 microns.
- Liquid charge the system

Access Valves: To use the access valves:

- Remove the cap from the stem, use a 3/16" allen wrench to check that the valve is CLOSED. The remove the core cap.
- Close the valve and replace the caps when done. The valve must be closed and the caps must be on or the valve will

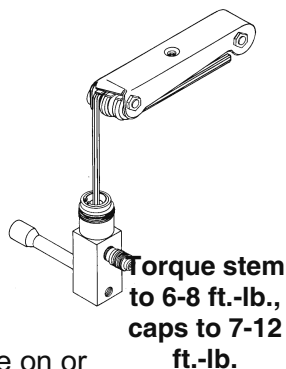

Instructions for Liquid Charging R-404A

In preparation for charging, the low side hose should have a sight glass, and/or a restricting device (such as a "Charge Faster") installed in it for metering liquid into the low side of the system.

1. After a thorough evacuation shut off the manifold valves and switch off the vacuum pump.
2. Place a drum of R-404A onto an electronic scale.
3. Attach the charging hose to the drum.
4. Open the valve on the drum and purge the charging hose.
5. Zero out the scale.
6. Shut the low side access valve at the ice machine.
7. Open the discharge manifold valve full open.
8. Watch the scale, when the correct charge is shown, shut the manifold valve.

Note: If all of the charge will not "go in" the discharge side:

- A. Shut the discharge access valve at the ice machine.
 - B. Switch the machine on.
 - C. Open the low side access valve at the ice machine.
 - D. Open the low side manifold valve and observe the sight glass to be certain that only gas is flowing into the system.
 - E. When the proper charge is indicated on the scale, shut off the manifold valve(s).
9. Shut off the valve on the refrigerant drum.
 10. Re-open the manifold valves until all liquid has flowed out of the hoses.
 11. Shut the low side access valve on the ice machine.
 12. Remove hoses from ice machine and replace all caps.

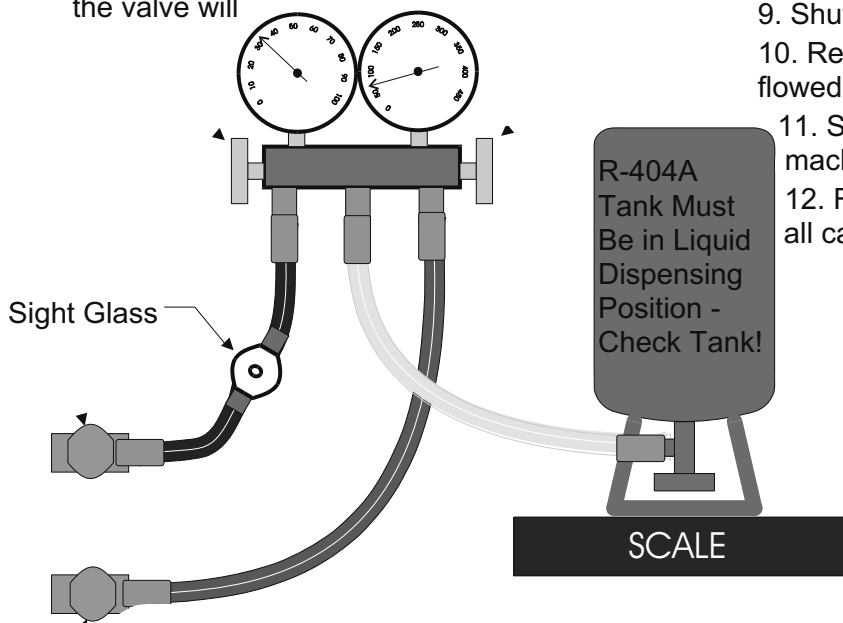

Hose Connection Schematic for Liquid Charging

NME454, 654 & FME504, 804

WHAT TO DO BEFORE CALLING FOR SERVICE

If the machine is off, not making ice:

1. Check the water supply to the ice machine. The machine is designed to shut off if there is no water to it. Check the filters if there are any.
2. Check the power supply to the machine. Reset the breaker if it is tripped.
3. If both water and power have been checked and are available, try switching the power Off and then On. After 2 minutes the machine should restart.

If this procedure restarts the machine, service should be called the next time the machine stops.