

NME954R & FME1204R SERVICE PARTS

This parts list contains the service parts and wiring diagrams for this model. Check the model number in question to be sure that it is applicable to this parts list.

TABLE OF CONTENTS

Cabinet	2
Refrigeration	3
Water	4
Gearmotor	5
NME Evaporator	6
FME Evaporator	7
Control Box	8
Remote Condenser	9
Wiring Diagrams	10

NME954R & FME1204R SERVICE PARTS

Cabinet Assembly

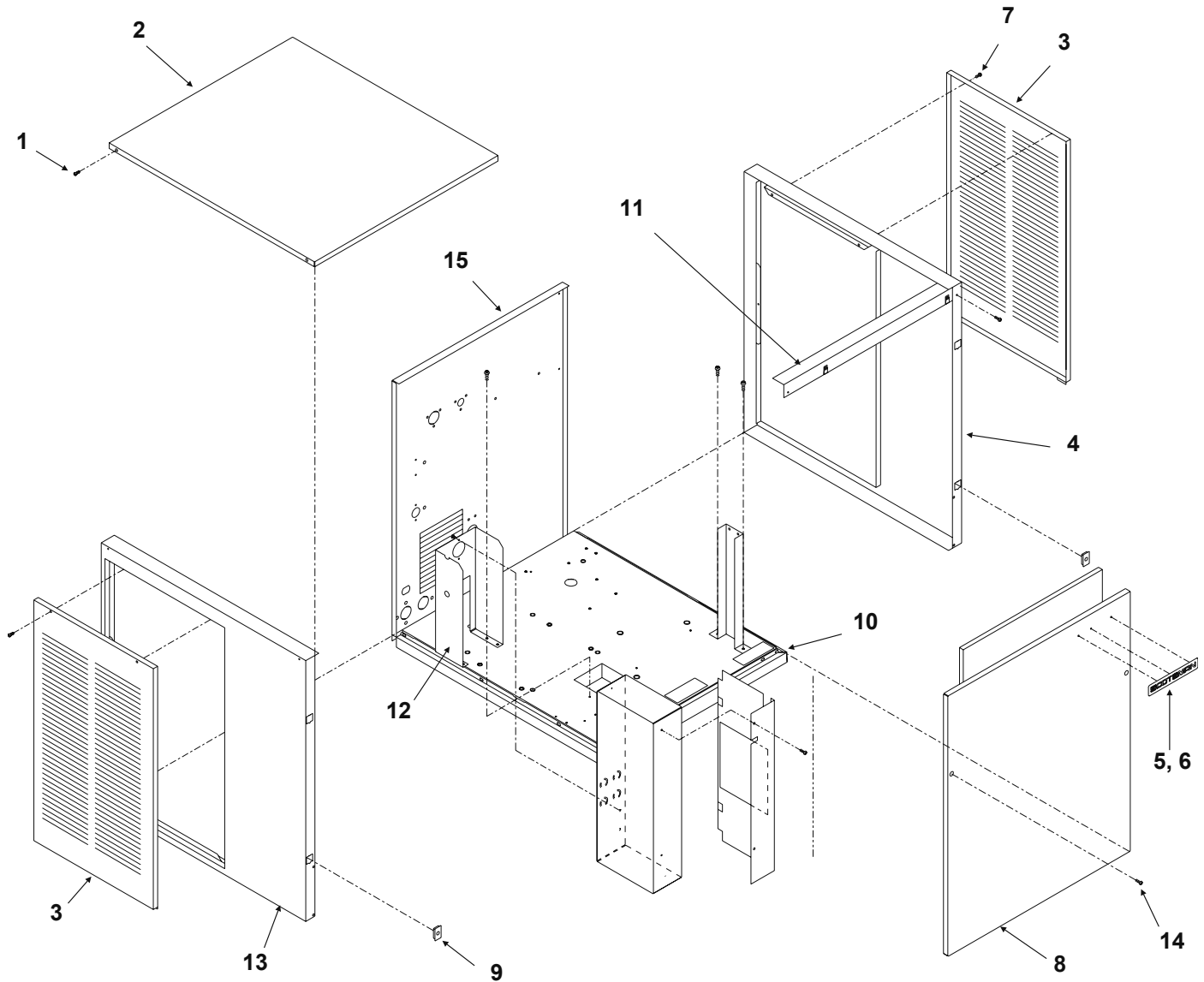

ITEM NUMBER	PART NUMBER	DESCRIPTION	ITEM NUMBER	PART NUMBER	DESCRIPTION
1	03-1531-01	Screw	8	A33255-002	Front panel, louvered
2	A33256-002	Top Panel, S.S.		A39048-001	Front panel, non-louvered
3	A33946-032	Service panel, louvered	9	02-0836-00	Catch
4	A33292-002	Right Side Panel, S.S.		15-0411-00	Strike (on front panel)
5	03-0271-00	Speed Clip	10	A35890-001	Base
6	15-0808-01	Emblem, gray	11	A34348-001	Ft. brace
7	03-1404-12	Screw	12	A34039-001	Control Box Support
			13	A32435-002	Left Side Panel, S.S.
			14	03-1419-22	Screw
			15	A35924-002	Rear panel, stainless

NME954R & FME1204R SERVICE PARTS

Refrigeration System

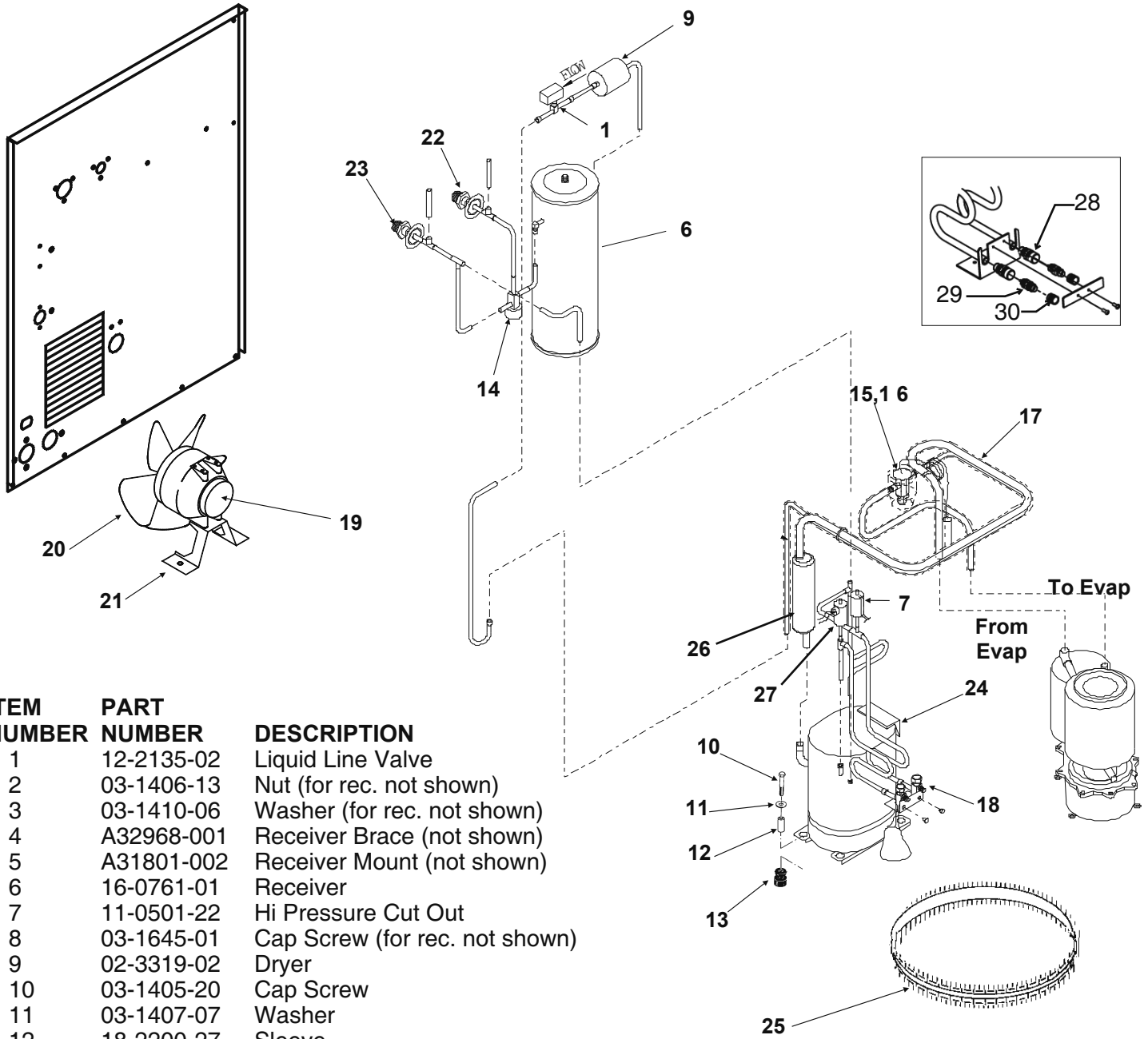

ITEM NUMBER	PART NUMBER	DESCRIPTION
1	12-2135-02	Liquid Line Valve
2	03-1406-13	Nut (for rec. not shown)
3	03-1410-06	Washer (for rec. not shown)
4	A32968-001	Receiver Brace (not shown)
5	A31801-002	Receiver Mount (not shown)
6	16-0761-01	Receiver
7	11-0501-22	Hi Pressure Cut Out
8	03-1645-01	Cap Screw (for rec. not shown)
9	02-3319-02	Dryer
10	03-1405-20	Cap Screw
11	03-1407-07	Washer
12	18-2200-27	Sleeve
13	18-2200-28	Rubber Grommet
14	11-0422-25	Head Pressure Valve
15	11-0488-21	Thermo Expansion Valve
16	A32961-020	Insulation Kit for TXV
17	A36496-001	Suction Line
18	16-0832-20	Access valve
18a	16-0832-02	Stem cap
18b	16-0832-03	Core cap
19	12-1576-02	Fan motor
20	18-8708-01	Fan blade
21	A35246-001	Fan bracket
22	16-0850-03	3/8" Male half
23	16-0850-01	1/2" Male half

ITEM NUMBER	PART NUMBER	DESCRIPTION
24	18-8768-22	Compressor 208-230/60/1 Overload for above is internal
	18-8768-24	Compressor 200-230/60/3 Overload for above is internal
25	12-1868-03	Crankcase Heater
Note: Compressors include a new HFC dryer.		
26.	16-0778-21	Accumulator
27	11-0502-21	Pump down control
28	16-1137-01	Access valve body
29	16-1139-01	Core
30	16-1140-01	cap

NME954R & FME1204R SERVICE PARTS

Water System, Water Seal

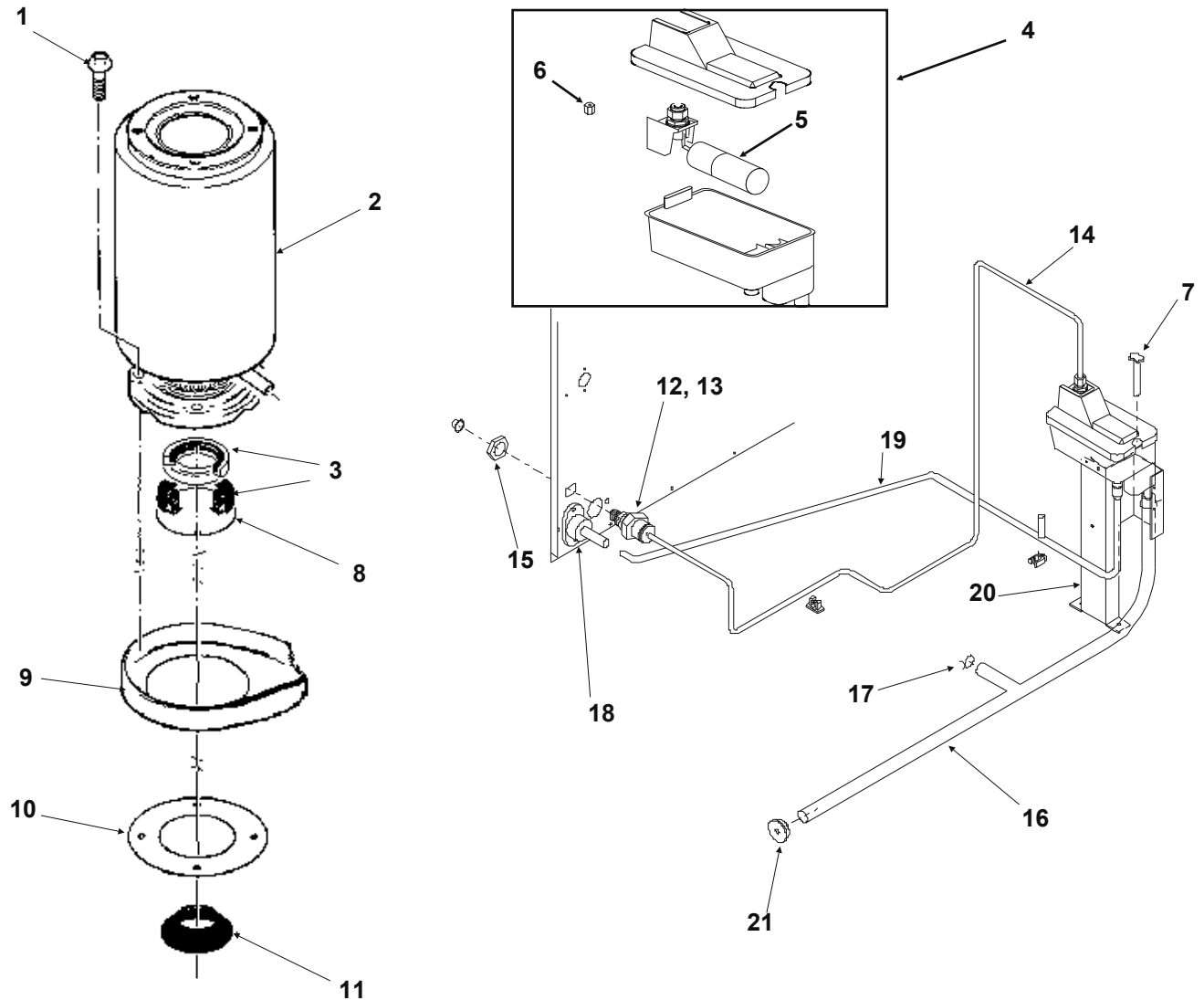

ITEM NUMBER	PART NUMBER	DESCRIPTION
1	03-1405-41	Cap Screw
2	A32890-020	Evaporator
3	02-0929-23	Water Seal
4	02-3266-01	Reservoir & valve
5	02-3266-02	Float valve
6	02-3266-03	Plunger/seat
7	12-2760-21	Water Level Sensor
8	A32777-001	Retaining Ring for Seal
9	02-3837-01	Drip Pan
10	13-0704-00	Gasket
11	02-4663-01	Water Shed

ITEM NUMBER	PART NUMBER	DESCRIPTION
15	03-1394-01	Pal nut
16	A36154-001	Evap. water inlet tube
17	02-1338-00	Hose clamp
18	02-3692-22	Drain fitting
19	02-3826-01	Res. overflow hose
20	A37482-001	Reservoir bracket
21	13-0840-01	Rubber cap

NME954R & FME1204R SERVICE PARTS

Gearmotor

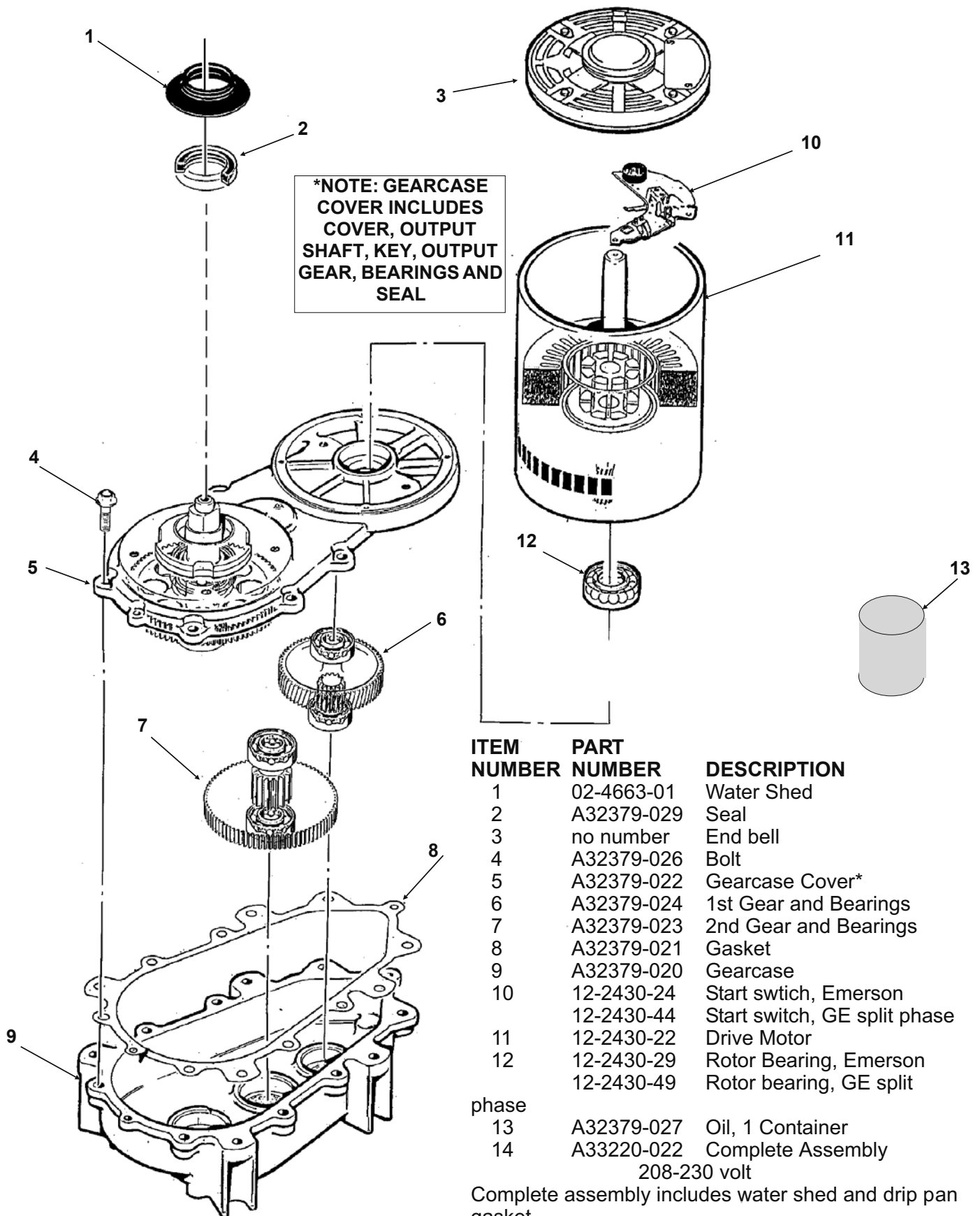

ITEM NUMBER	PART NUMBER	DESCRIPTION
1	02-4663-01	Water Shed
2	A32379-029	Seal
3	no number	End bell
4	A32379-026	Bolt
5	A32379-022	Gearcase Cover*
6	A32379-024	1st Gear and Bearings
7	A32379-023	2nd Gear and Bearings
8	A32379-021	Gasket
9	A32379-020	Gearcase
10	12-2430-24	Start switch, Emerson
	12-2430-44	Start switch, GE split phase
11	12-2430-22	Drive Motor
12	12-2430-29	Rotor Bearing, Emerson
	12-2430-49	Rotor bearing, GE split phase
13	A32379-027	Oil, 1 Container
14	A33220-022	Complete Assembly 208-230 volt
Complete assembly includes water shed and drip pan gasket.		
15	A33220-030	Gear case kit, no motor

NME954R & FME1204R SERVICE PARTS

NME Evaporator, Bin Controls

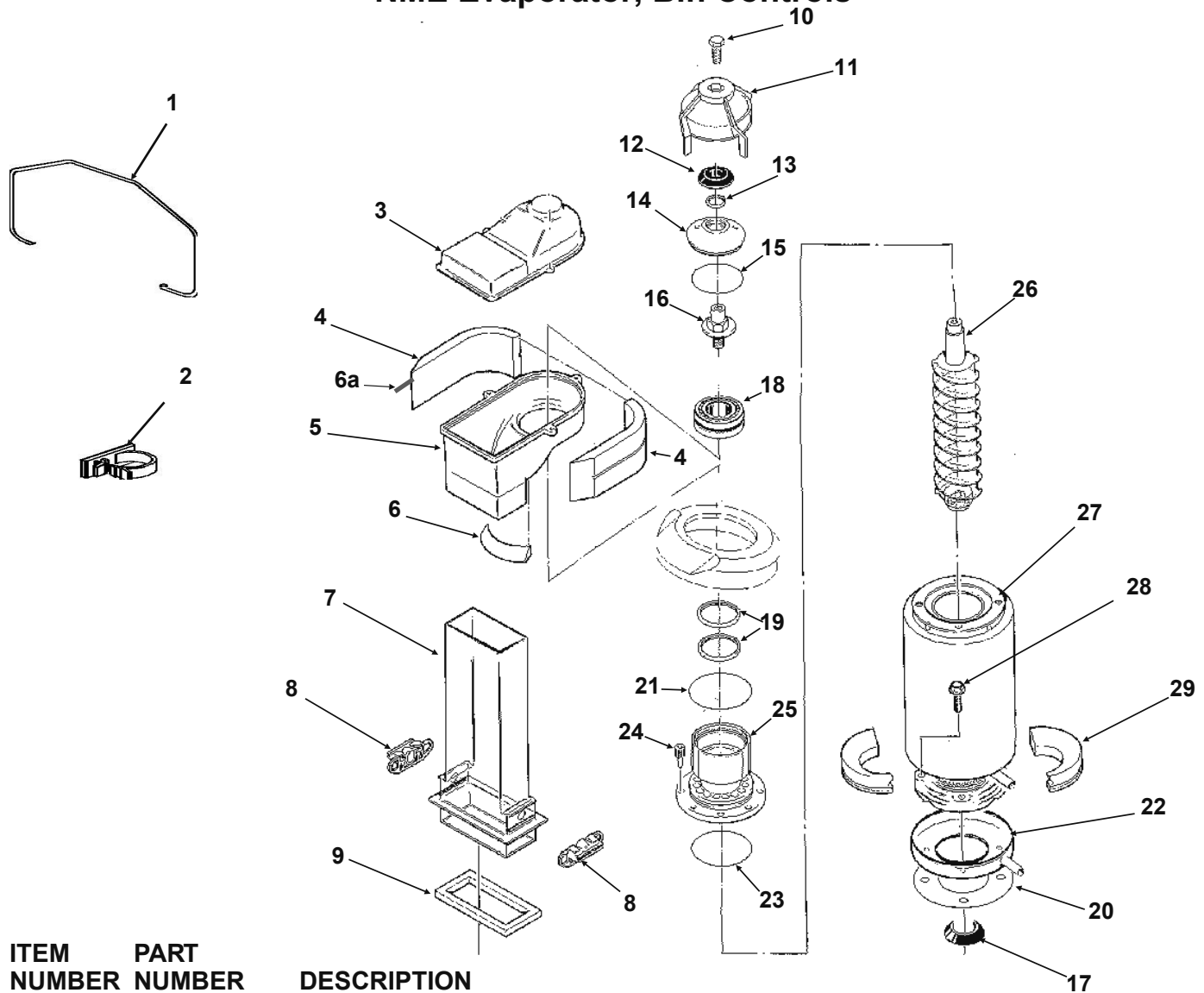

ITEM NUMBER	PART NUMBER	DESCRIPTION
1.	A34969-001	Bail clip
2.	02-3268-01	Drain tube holder
3.	02-2930-04	Ice Chute Cover
4.	A32963-001	Insulation Top (half)*
5.	02-3841-01	Ice Chute Body*
6.	A33102-001	Insulation Collar Inside*
6a	A35419-020	Strap kit*
7.	02-2929-04	Ice Chute Lower
8.	A37708-021	Bin Controls Assy. (set of 2)
9.	A32930-001	Chute Gasket
10.	03-1405-52	Hex Cap Screw
11.	02-3001-01	Ice Sweep
12.	13-0871-01	Water Shed
13.	02-2978-01	Lip Seal
14.	02-3128-20	Breaker Cover
15.	13-0617-52	O-Ring
16.	08-0660-01	Auger Stud & washer
17.	02-4663-01	Water Shed
18.	A34559-020	Bearing
19.	02-2977-01	Lip Seal
20.	13-0704-00	Drip Pan Gasket
21.	13-0617-54	O-Ring
22.	02-3837-01	Drip Pan
23.	13-0617-45	O-Ring
24.	03-1544-08	Soc. Head Screw
25.	A32900-020	Breaker (includes 18 & 19)
26.	A38071-022	Auger
27.	A32890-020	Evaporator
28.	03-1405-41	Cap Screw
29.	02-4358-01	Insulation
30.	13-0929-02	Insulation donut*

* Insulation changed Oct 2002. Items 4, 6 and 6a no longer used. Item 5 changed. Item 30 added.

NME954R & FME1204R SERVICE PARTS

FME Evaporator, Bin Controls

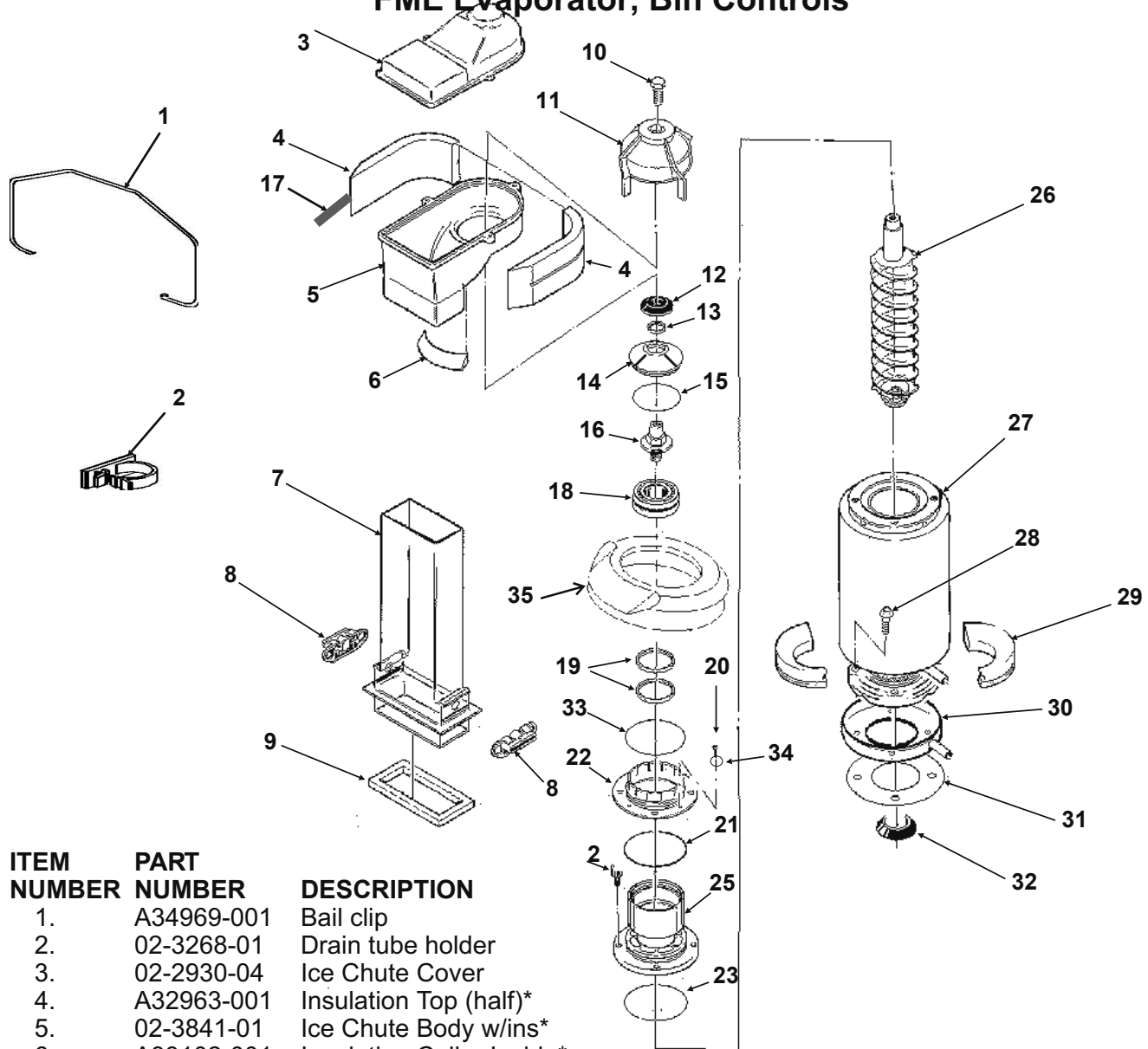

ITEM NUMBER	PART NUMBER	DESCRIPTION
1.	A34969-001	Bail clip
2.	02-3268-01	Drain tube holder
3.	02-2930-04	Ice Chute Cover
4.	A32963-001	Insulation Top (half)*
5.	02-3841-01	Ice Chute Body w/ins*
6.	A33102-001	Insulation Collar Inside*
7.	02-2929-04	Ice Chute Lower
8.	A37708-021	Bin Controls Assy.
9.	A32930-001	Chute Gasket
10.	03-1405-52	Hex Cap Screw
11.	02-3001-01	Ice Sweep
12.	13-0871-01	Water Shed
13.	02-2978-01	Lip Seal
14.	02-3128-20	Breaker Cover
15.	13-0617-54	O-Ring
16.	08-0660-01	Auger Stud
17.	A35419-020	Strap kit*
18.	A34559-020	Bearing
19.	02-2977-01	Lip Seal
20.	03-1405-27	Screw
21.	13-0617-52	O-Ring
22.	02-2916-01	Slotted Collar
23.	13-0617-45	O-Ring
24.	03-1544-08	Soc. Head Screw
25.	A34505-020	Breaker (Divider) (includes 18 & 19)
26.	A38071-022	Auger
27.	A32890-020	Evaporator
28.	03-1405-21	Cap Screw
29.	02-4358-01	Insulation
30.	02-3837-01	Drip Pan
31.	13-0704-00	Drip Pan Gasket
32.	02-4663-01	Water Shed
33.	13-0617-49	O-Ring
34.	03-1408-36	Washer
35.	13-0929-01	Insulation donut*

* Insulation changed Oct. 2000. Items 4, 6 and 17 no longer used. Item 35 added. item 5 changed.

NME954R & FME1204R SERVICE PARTS

Control Box

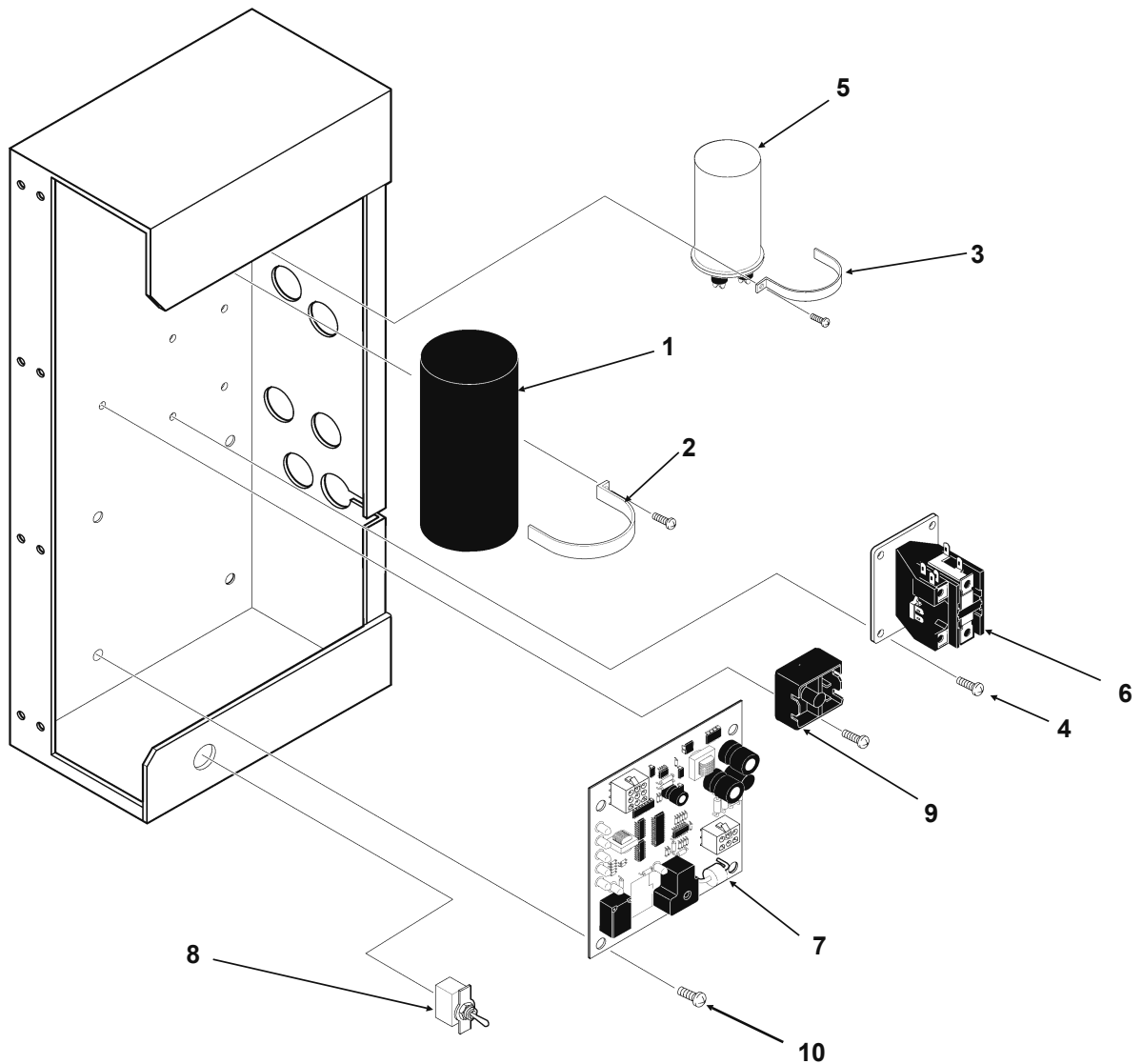

ITEM NUMBER	PART NUMBER	DESCRIPTION
1	18-1901-54	Start Capacitor
2.	A35971-001	Start Capacitor Bracket
3.	A35971-002	Run Cap Bracket
4.	03-1638-03	Screw
5.	18-1902-45	Run Capacitor
6.	12-2469-02	Single Phase Contactor
	12-2533-02	Three Phase Contactor

ITEM NUMBER	PART NUMBER	DESCRIPTION
7	12-2835-22	Circuit Board
8.	12-0426-02	Mode Switch
9.	18-1903-33	Potential Relay
10	12-2350-01	Spacer/screw

NOT ILLUSTRATED		
11	A37861-001	Control box cover



NME954R & FME1204R SERVICE PARTS REMOTE CONDENSER

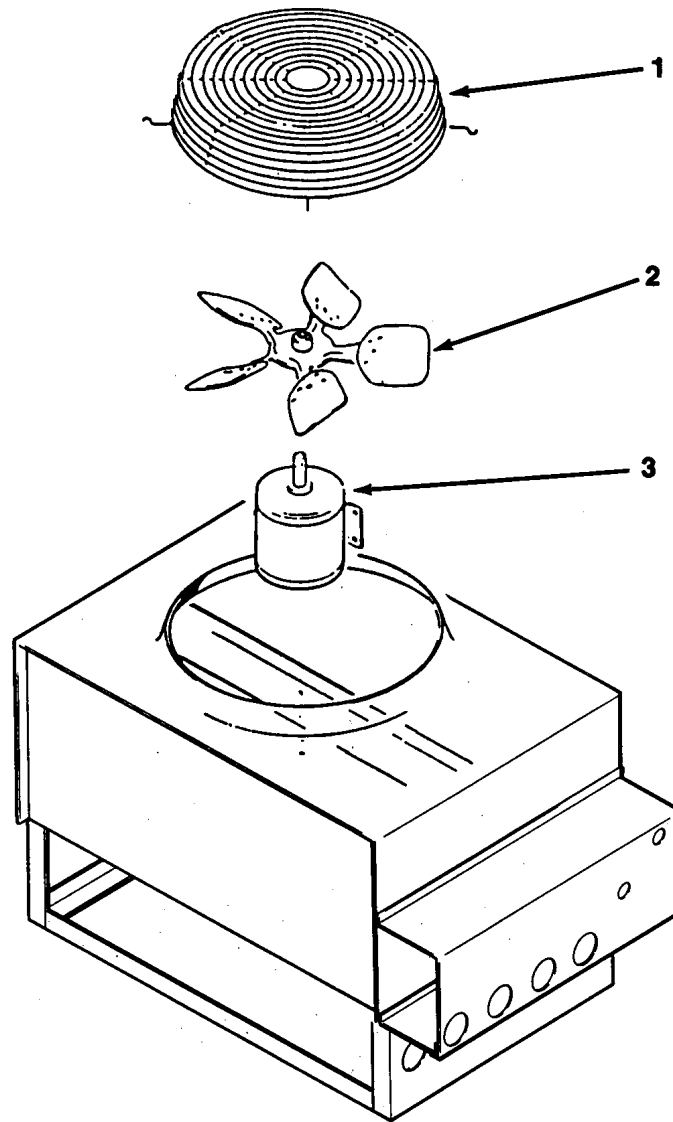

ERC151-32 or ERC302-32

ITEM NUMBER	PART NUMBER	DESCRIPTION
1	02-3575-01	Fan guard
2	18-8800-01	Fan blade
3	18-8796-32	Fan motor

NME954R & FME1204R SERVICE PARTS

Wiring Diagram, 208-230/60/1

17-2683-01

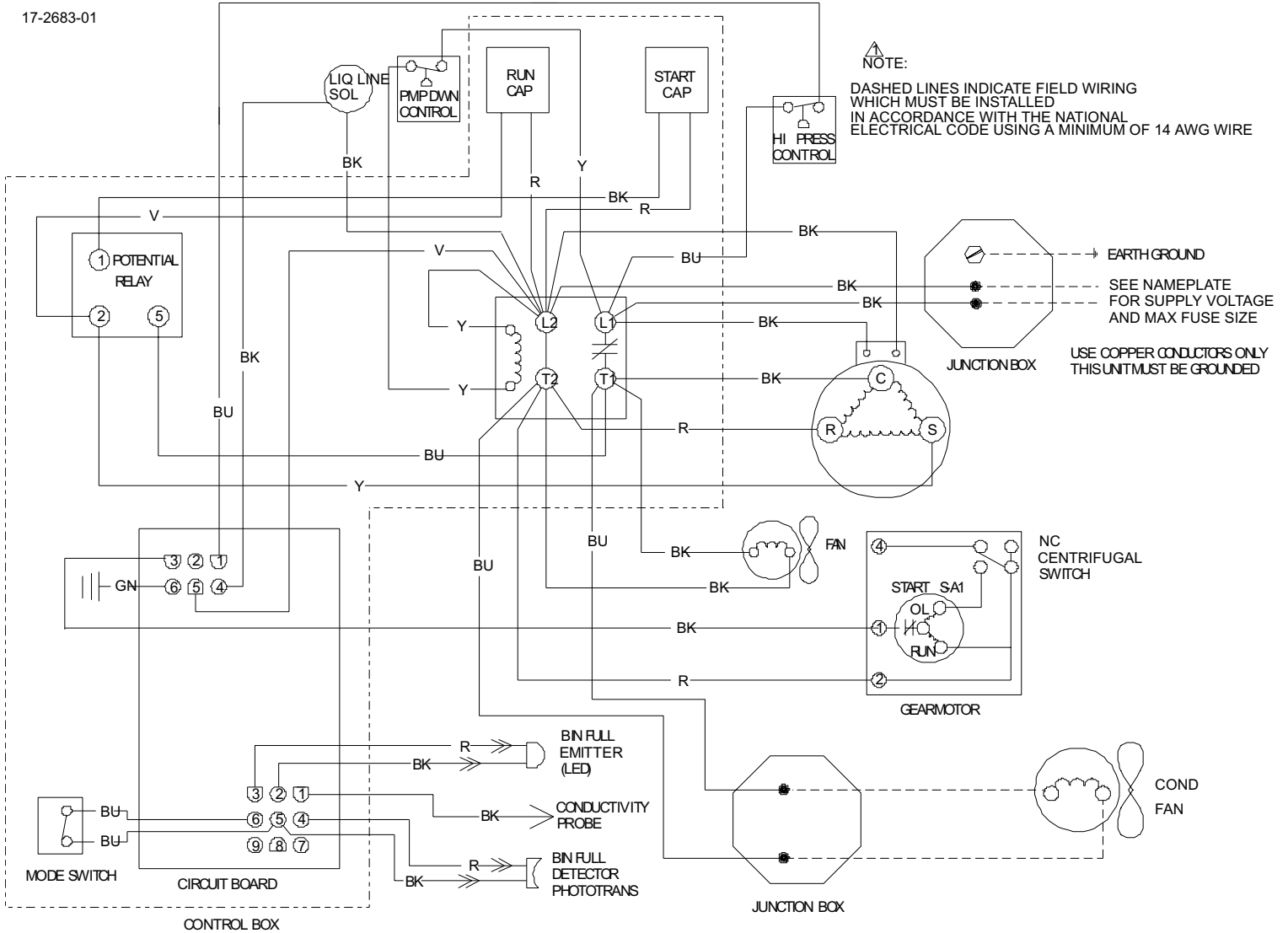

NME954R & FME1204R SERVICE PARTS

Schematic Diagram, 208-230/60/1

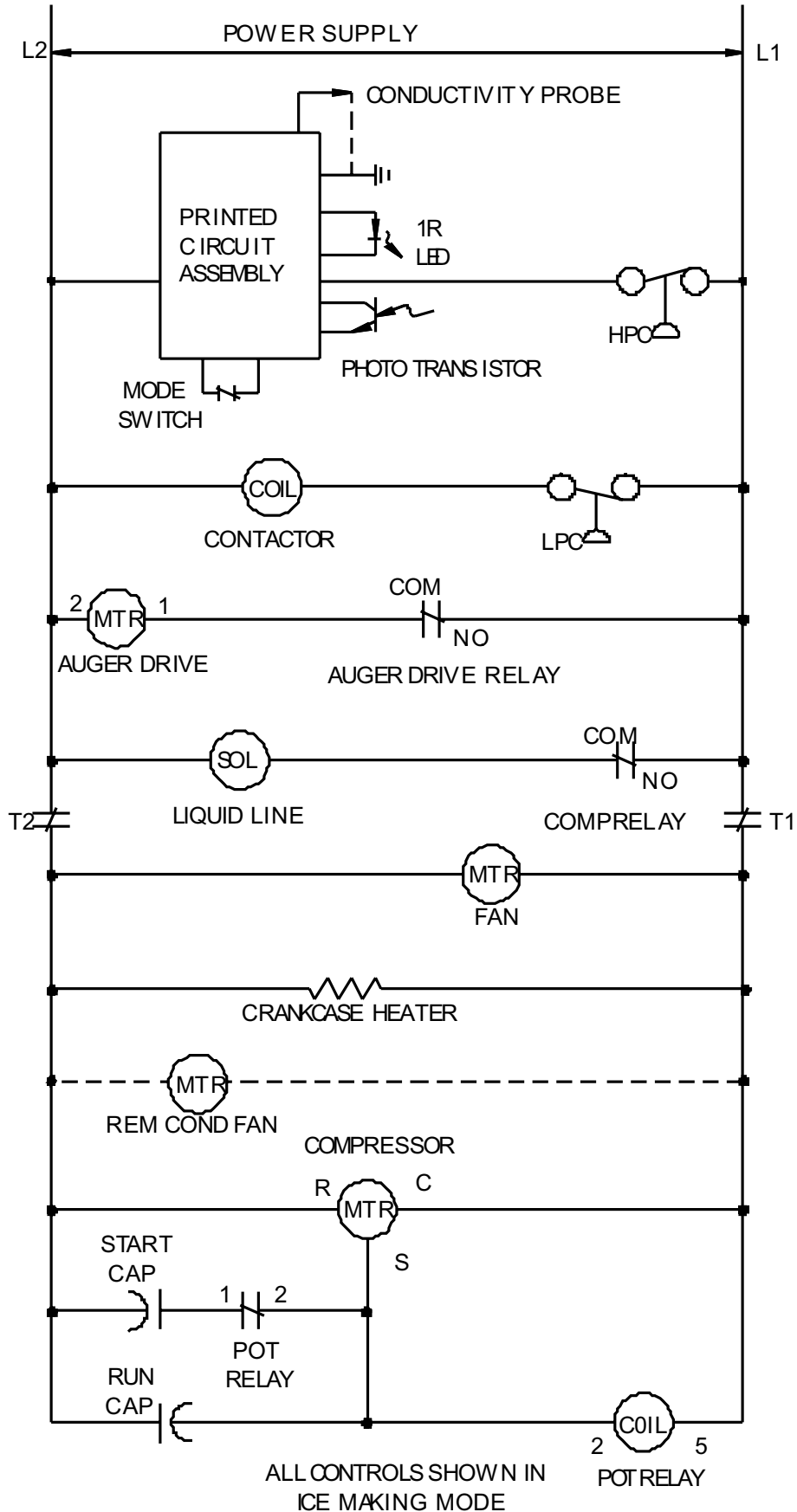

NME954R & FME1204R SERVICE PARTS

Wiring Diagram, 208-230/60/3

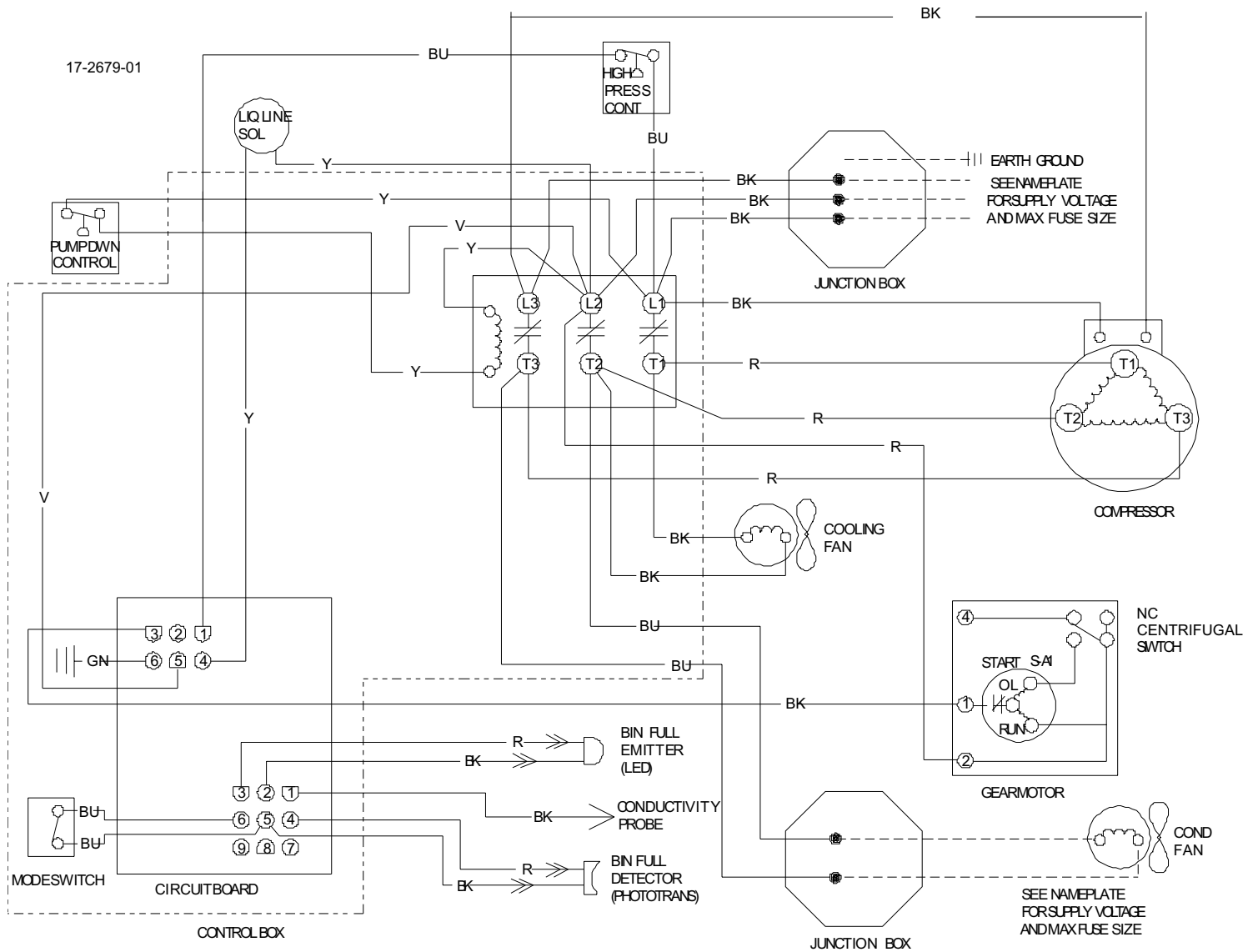

NME954R & FME1204R SERVICE PARTS

Schematic Diagram, 208-230/60/3

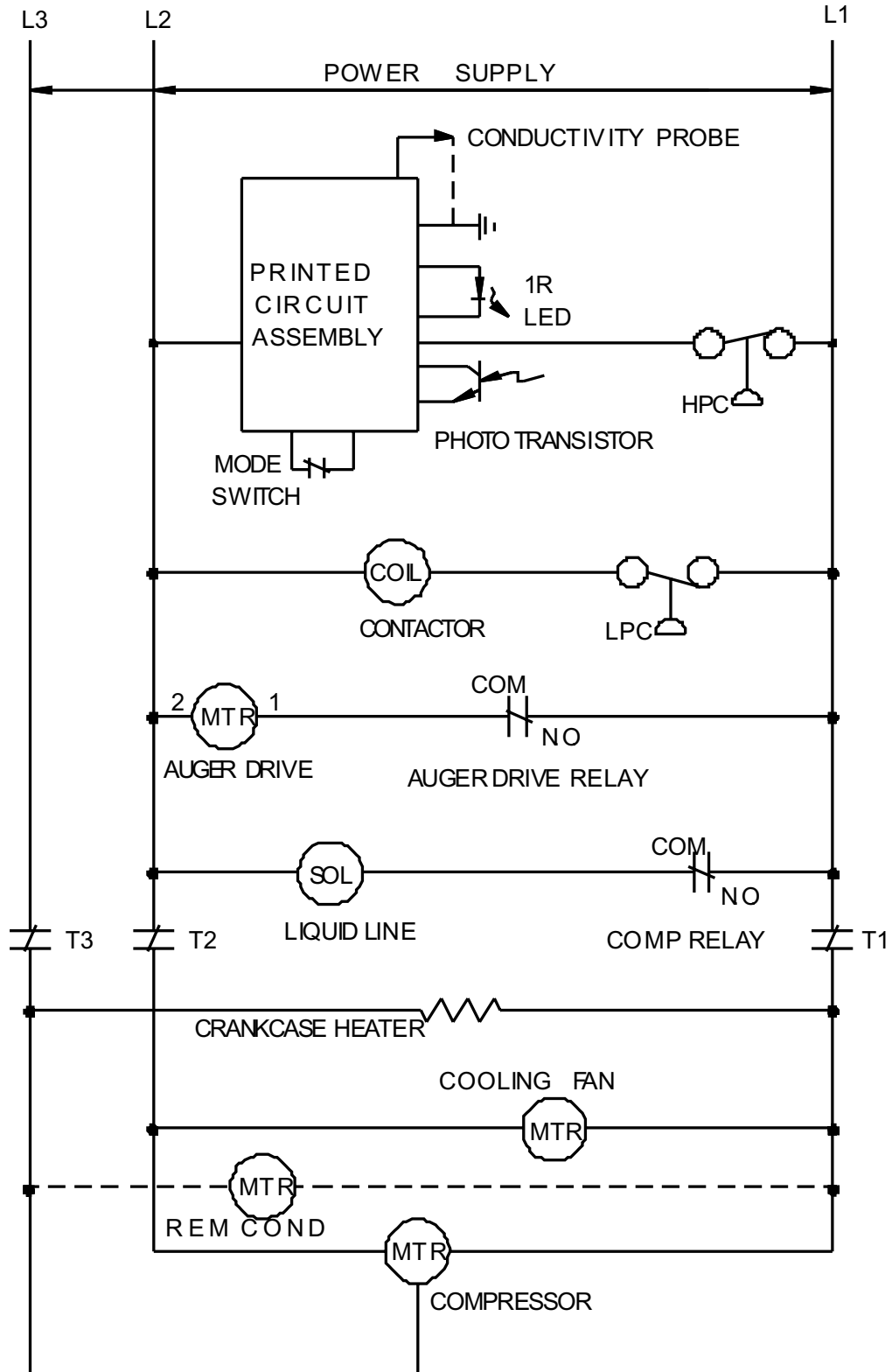

NOTE:
 DASHED LINES INDICATE FIELD WIRING
 WHICH MUST BE INSTALLED
 IN ACCORDANCE WITH THE NATIONAL
 ELECTRICAL CODE USING A MINIMUM OF 14 AWG WIRE

SCOTSMAN®

Bulletin Number: PS-14-96

Bulletin Date: September 1996

SERVICE BULLETIN

Subject: NME, FME, NSE, NDE and TDE550/650 Top Bearing Lubrication

Two parts have been made available as helpful aids to use when lubricating the top bearing.

1. **02-3559-01** is a needle that snaps onto a standard grease gun fitting. Use it to insert and deeply pack the proper lubricant into the top bearing.
2. **A36808-001** is a tube of the proper lubricant, also designed to fit a standard grease gun.

Both numbers are in the parts price list.

Needle, shown inserted into bearing

