

NSE654 SERVICE PARTS

This parts list contains the service part numbers and wiring diagrams for this model. Check the model number of the unit being serviced to be sure that this list is the correct one.

The water cooled B series has a different water cooled condenser than the A series. Be sure to check the complete model number when ordering a water cooled condenser.

TABLE OF CONTENTS

Cabinet	Page 2
Refrigeration	Page 3
Water System	Page 4
Evaporator	Page 5
Gearmotor	Page 6
Ice Level Sensor	Page 7
Control Box	Page 8
Wiring Diagrams	Page 9

NSE654 SERVICE PARTS

Cabinet

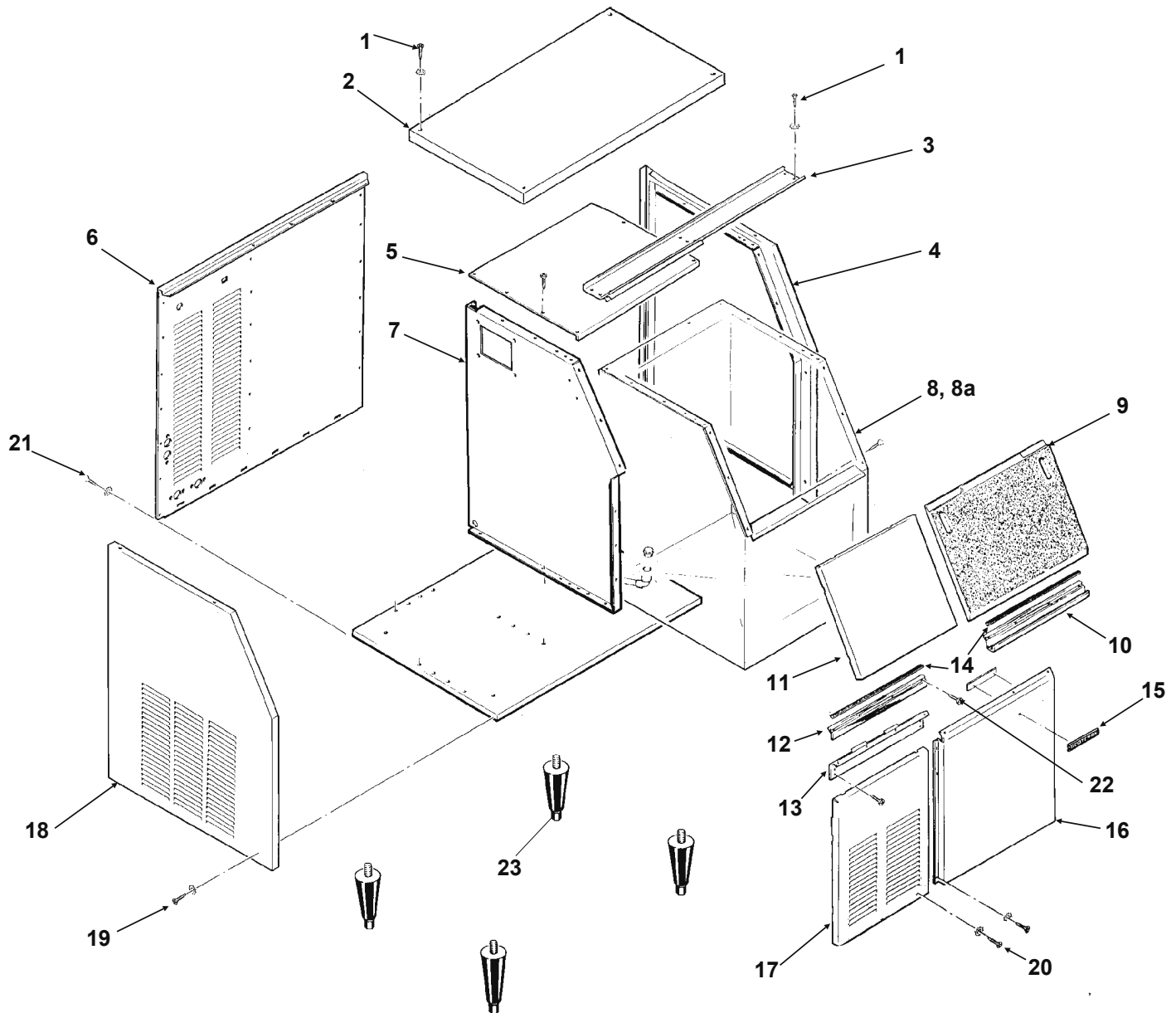

ITEM NUMBER	PART NUMBER	DESCRIPTION
1	03-1419-19	Screw
2	A30494-002	Top Panel, Stainless
3	A37397-001	Door Track Assembly
4	A24800-002	Rt. Side Panel, Stainless
5	A34422-001	Bin Cover
6	A35913-002	Back Panel
7	A33952-015	Retainer
8	A34421-001	Ice Storage Bin
8a	A29923-001	Trim strip
9	02-2130-34	Door, Gray
10	15-0620-01	Moulding Right
11	A30497-002	Upper front panel, stainless
12	15-0706-01	Moulding, left
13	A33958-001	Bracket
14	15-0324-00	Black insert 37"
15	15-0808-01	Emblem
16	A24794-002	Rt. Front Panel, stainless
17	A33968-002	Lower left front, stainless
18	A27034-002	Left side panel, stainless
19	03-1531-01	Screw
20	03-1419-16	Screw
21	03-1638-03	Screw
22	03-1419-17	Screw
23	KLP2E	Leg, kit of 4

NSE654 SERVICE PARTS

Refrigeration System

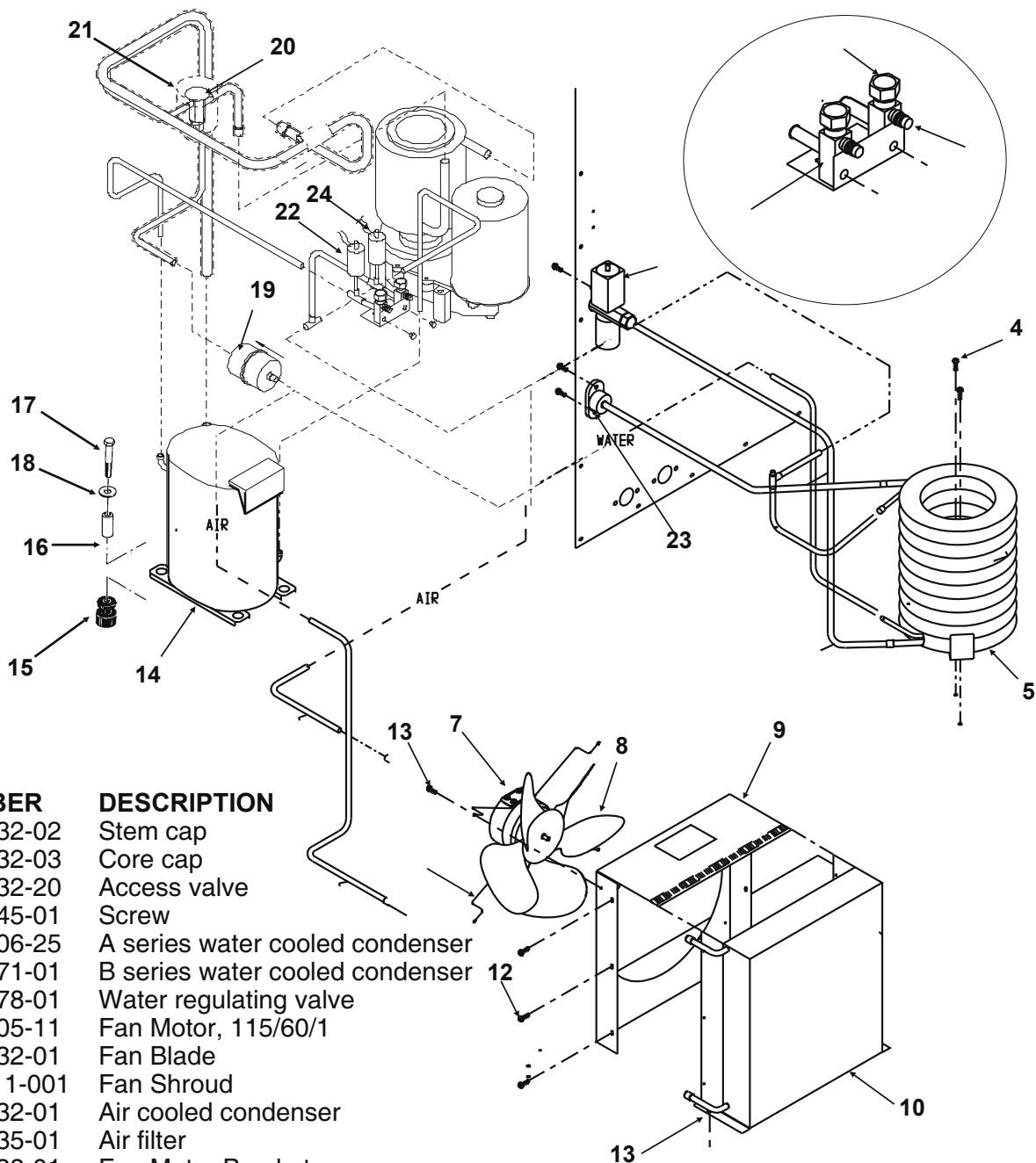

ITEM NUMBER	PART NUMBER	DESCRIPTION
1	16-0832-02	Stem cap
2	16-0832-03	Core cap
3	16-0832-20	Access valve
4	03-1645-01	Screw
5	18-3306-25	A series water cooled condenser
	18-8871-01	B series water cooled condenser
6	11-0478-01	Water regulating valve
7	18-5105-11	Fan Motor, 115/60/1
8	18-3732-01	Fan Blade
9	A35911-001	Fan Shroud
10	18-8732-01	Air cooled condenser
	02-3935-01	Air filter
11	02-3333-01	Fan Motor Bracket
12	03-1404-03	Screw
13	03-1645-01	Screw
14	18-8721-21	Compressor 115/60/1
	18-8711-50	Compressor overload
15	18-2200-28	Grommet
16	18-2200-27	Sleeve
17	03-1405-40	Bolt
18	03-1408-29	Washer
19	02-3319-02	Drier
20	11-0488-21	Thermo Expansion valve
21	A32961-020	Insulation Kit (3 piece)
22	11-0501-22	Hi Pressure Cut Out
23	A31828-002	Drain casting
24	11-0502-21	Low pressure cut out

NSE654 SERVICE PARTS

Water System

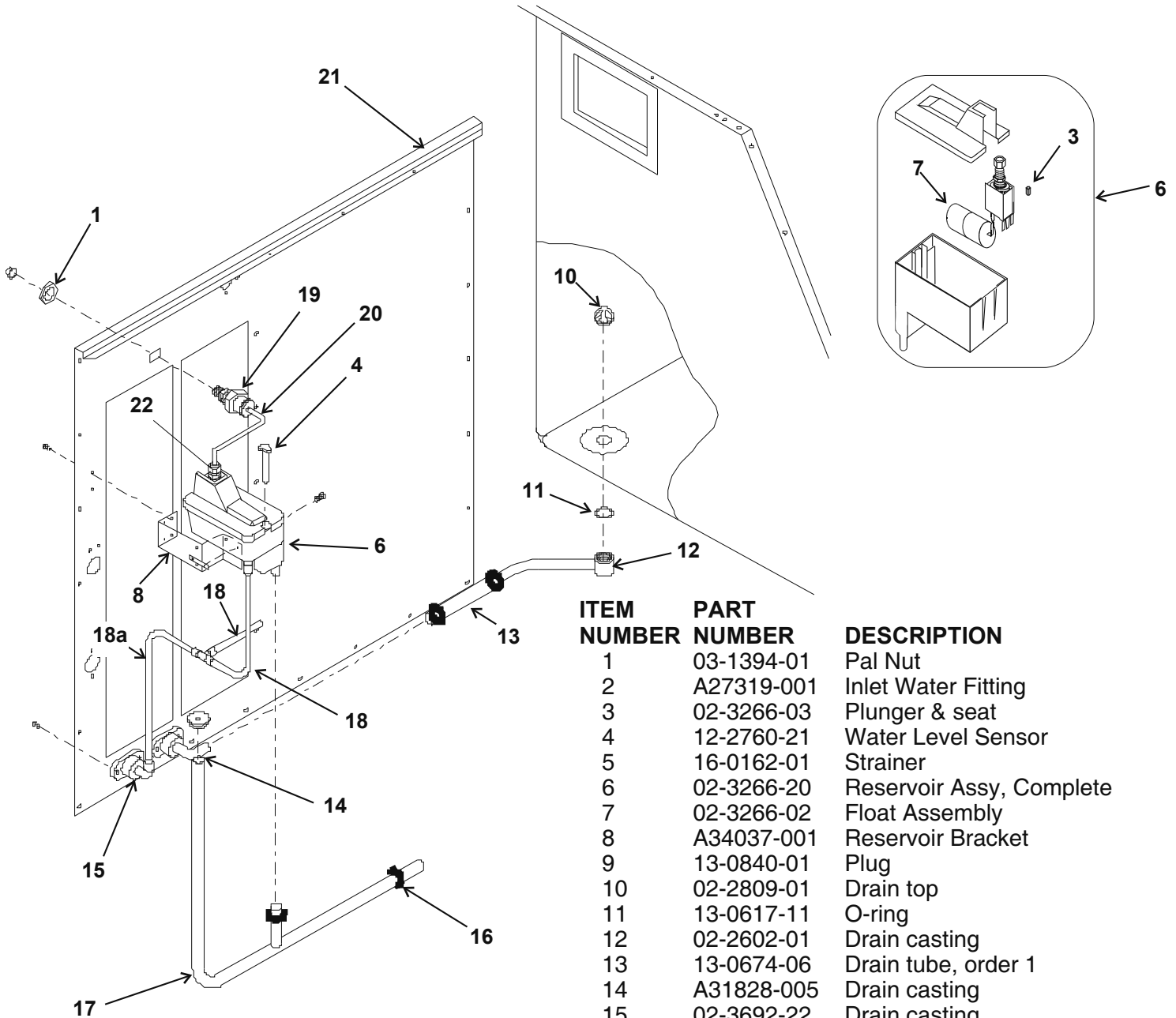

ITEM NUMBER	PART NUMBER	DESCRIPTION
1	03-1394-01	Pal Nut
2	A27319-001	Inlet Water Fitting
3	02-3266-03	Plunger & seat
4	12-2760-21	Water Level Sensor
5	16-0162-01	Strainer
6	02-3266-20	Reservoir Assy, Complete
7	02-3266-02	Float Assembly
8	A34037-001	Reservoir Bracket
9	13-0840-01	Plug
10	02-2809-01	Drain top
11	13-0617-11	O-ring
12	02-2602-01	Drain casting
13	13-0674-06	Drain tube, order 1
14	A31828-005	Drain casting
15	02-3692-22	Drain casting
16	02-1338-00	Hose clamp
17	A36154-003	Inlet hose
18	13-0079-03	Drain hose, 2 ft. req.
18a	13-0079-03	Drain hose, 1 ft. req.
19	16-0835-01	Water inlet fitting
	16-1039-01	Male connector
20	13-0895-01	Water inlet tubing, 1 ft. req.
21	A35913-002	Back panel
22	16-0871-01	Insert

NSE654 SERVICE PARTS

Evaporator

ITEM NUMBER	PART NUMBER	DESCRIPTION
1	03-1405-41	Cap Screw
	03-1417-13	Lockwasher
2	A33194-020	Evaporator
3	A32962-001	Insulation Half
4	A32962-002	Insulation Half
5	02-0929-23	Water Seal
6	A32777-001	Retaining ring for seal
7	02-3837-01	Drip Pan

ITEM NUMBER	PART NUMBER	DESCRIPTION
8	13-0704-00	Gasket
9	13-0868-01	Water Shed
10	02-2977-01	Lip Seal
11	13-0617-54	O-Ring
12	A32900-020	Breaker (includes 10 & 14)
13	03-1544-08	Soc. head screw
14	13-0617-45	O-Ring
15	03-1405-52	Hex Cap Screw
16	02-3001-01	Ice Sweep
17	13-0871-01	Water Shed
18	02-2978-01	Lip Seal
19	02-3128-20	Breaker cover
20	13-0617-52	O-Ring
21	08-0660-01	Auger Stud
22	A34559-020	Bearing
23	A38071-021	Auger

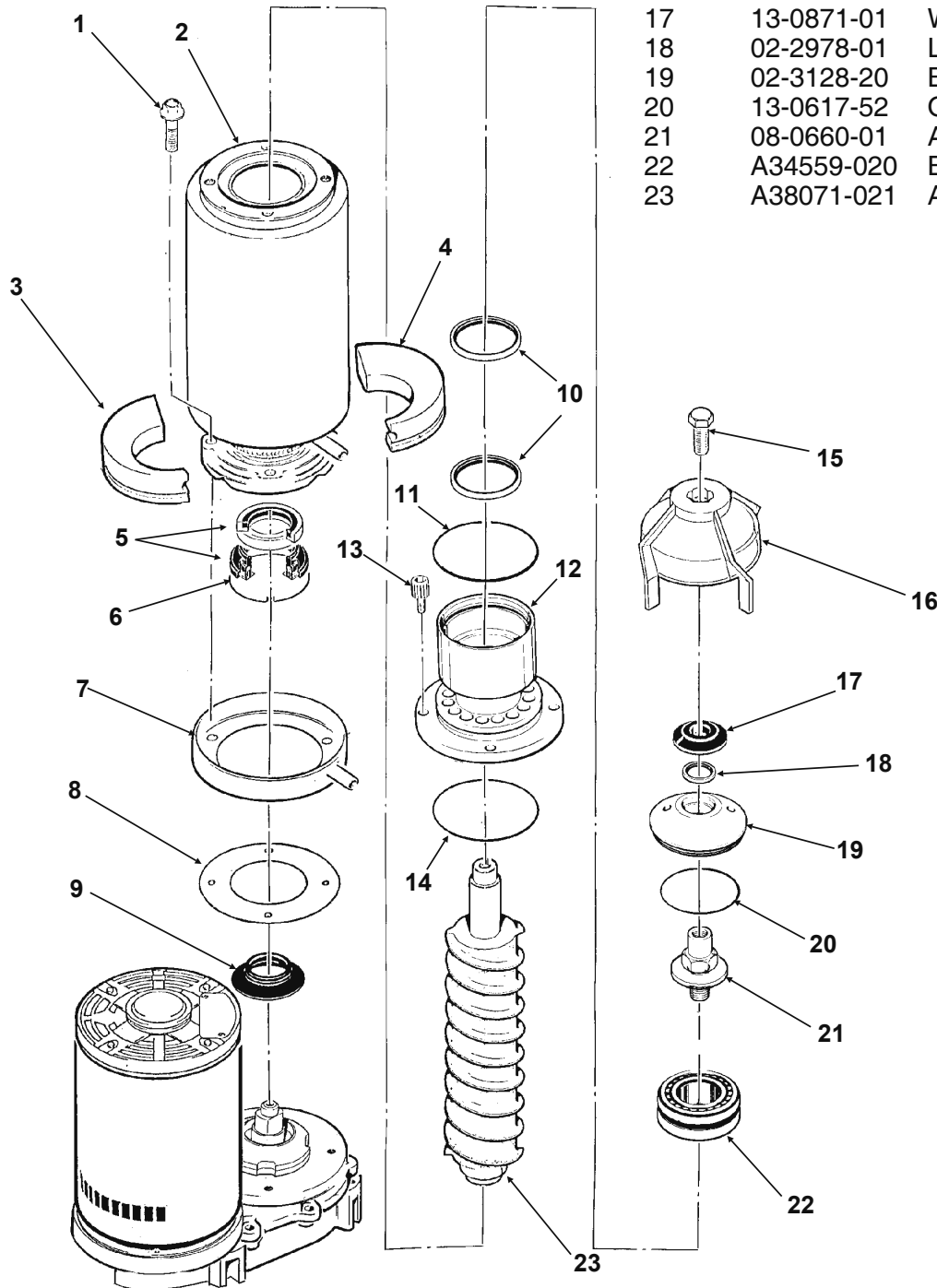

NSE654 SERVICE PARTS

Gearmotor Assembly

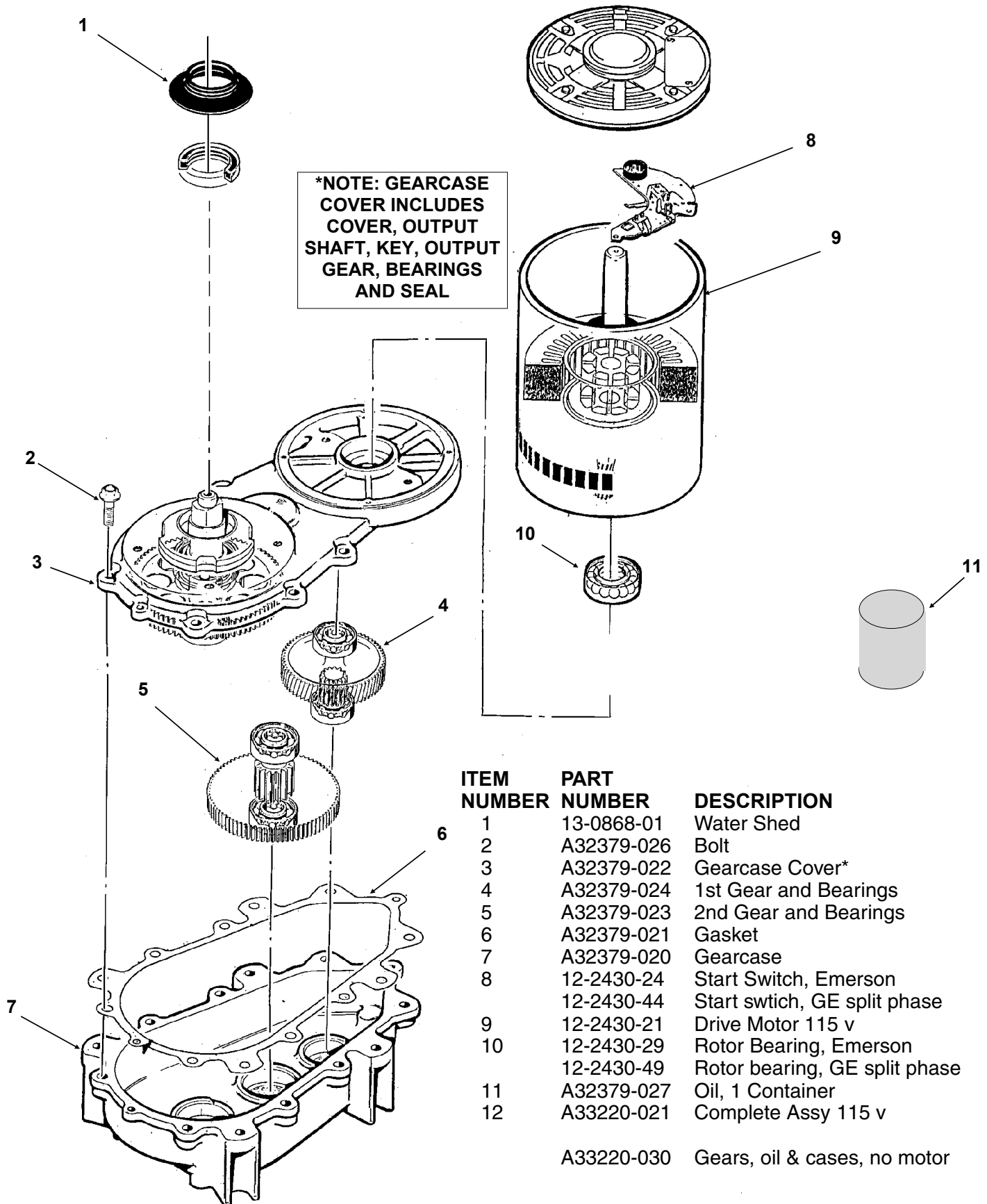

***NOTE: GEARCASE COVER INCLUDES COVER, OUTPUT SHAFT, KEY, OUTPUT GEAR, BEARINGS AND SEAL**

ITEM NUMBER	PART NUMBER	DESCRIPTION
1	13-0868-01	Water Shed
2	A32379-026	Bolt
3	A32379-022	Gearcase Cover*
4	A32379-024	1st Gear and Bearings
5	A32379-023	2nd Gear and Bearings
6	A32379-021	Gasket
7	A32379-020	Gearcase
8	12-2430-24	Start Switch, Emerson
	12-2430-44	Start swtich, GE split phase
9	12-2430-21	Drive Motor 115 v
10	12-2430-29	Rotor Bearing, Emerson
	12-2430-49	Rotor bearing, GE split phase
11	A32379-027	Oil, 1 Container
12	A33220-021	Complete Assy 115 v
	A33220-030	Gears, oil & cases, no motor

NSE654 SERVICE PARTS

Ice Level Sensors and Ice Chute

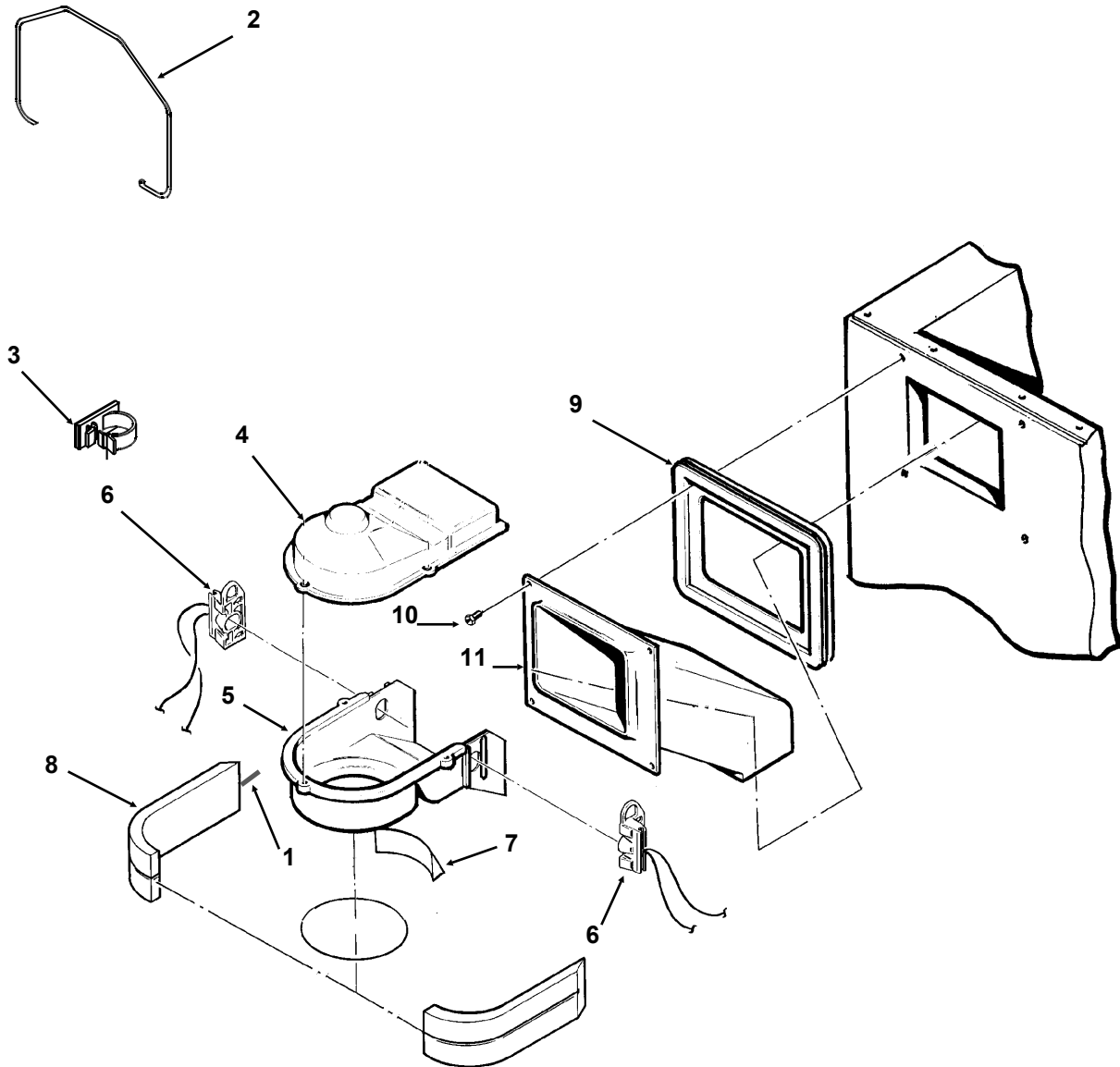

ITEM NUMBER	PART NUMBER	DESCRIPTION
1	A35419-020	Strap kit
2	A34969-001	Bail clamp
3	02-3268-01	Drain tube clip holder
4	02-2957-02	Ice chute cover
5	02-2958-01	Ice chute body
6	A37711-021	Ice level sensors
7	A33102-001	Insulation
8	A32963-001	Insulation half
9	13-0867-01	Grommet
10	03-1531-01	Screw
11	02-2973-01	Chute extension

NSE654 SERVICE PARTS

Control Box

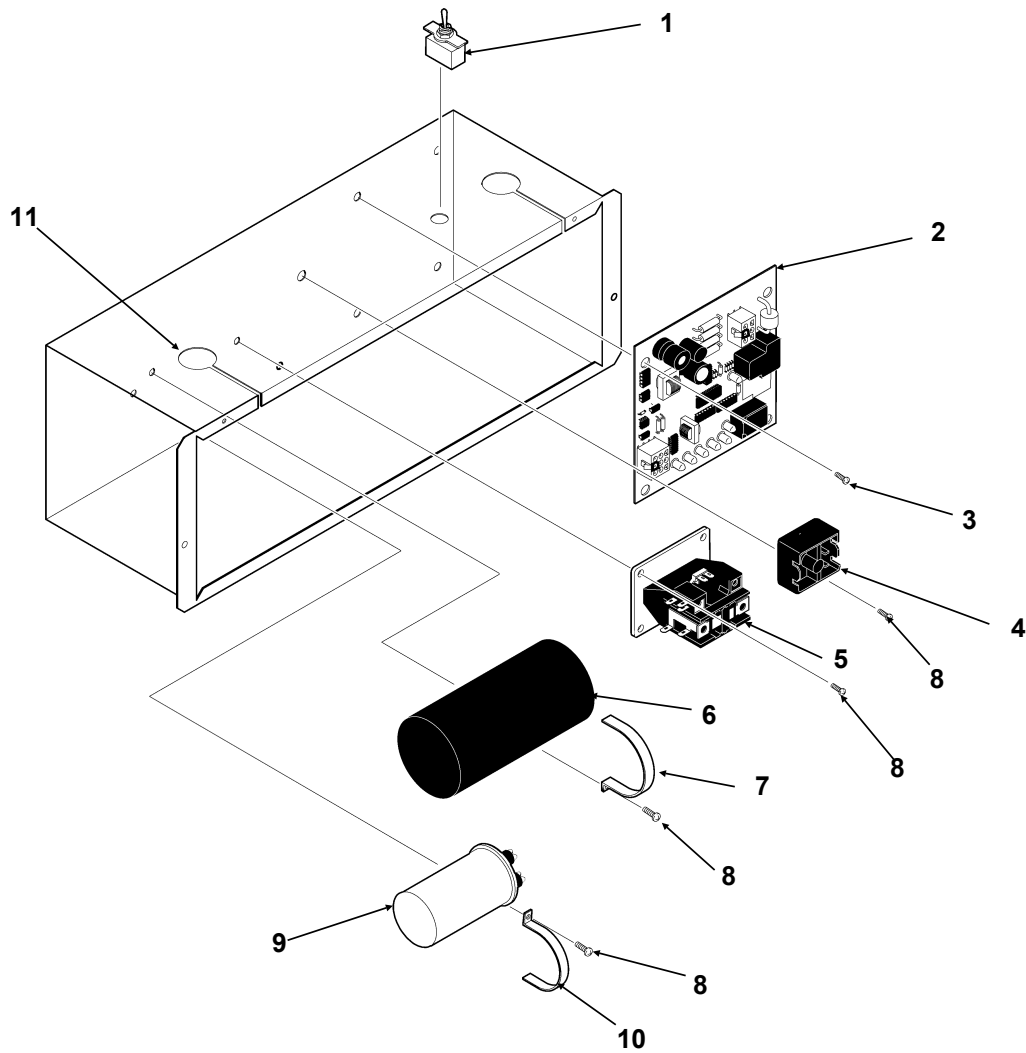

ITEM NUMBER	PART NUMBER	DESCRIPTION
1	12-0426-01	Mode Switch
2	12-2835-21	Control Board
3	12-2350-01	Stand off
4	18-1903-50	Potential Relay
5	12-2469-03	Contactor
6	18-1901-03	Start Capacitor
7	A35971-002	Start Capacitor Bracket
8	03-1531-01	Screw
9	18-1902-45	Run capacitor
10	A35971-001	Run capacitor bracket
11	12-1213-11	Bushing

NSE654 SERVICE PARTS Component Layout Diagram

17-2701-01

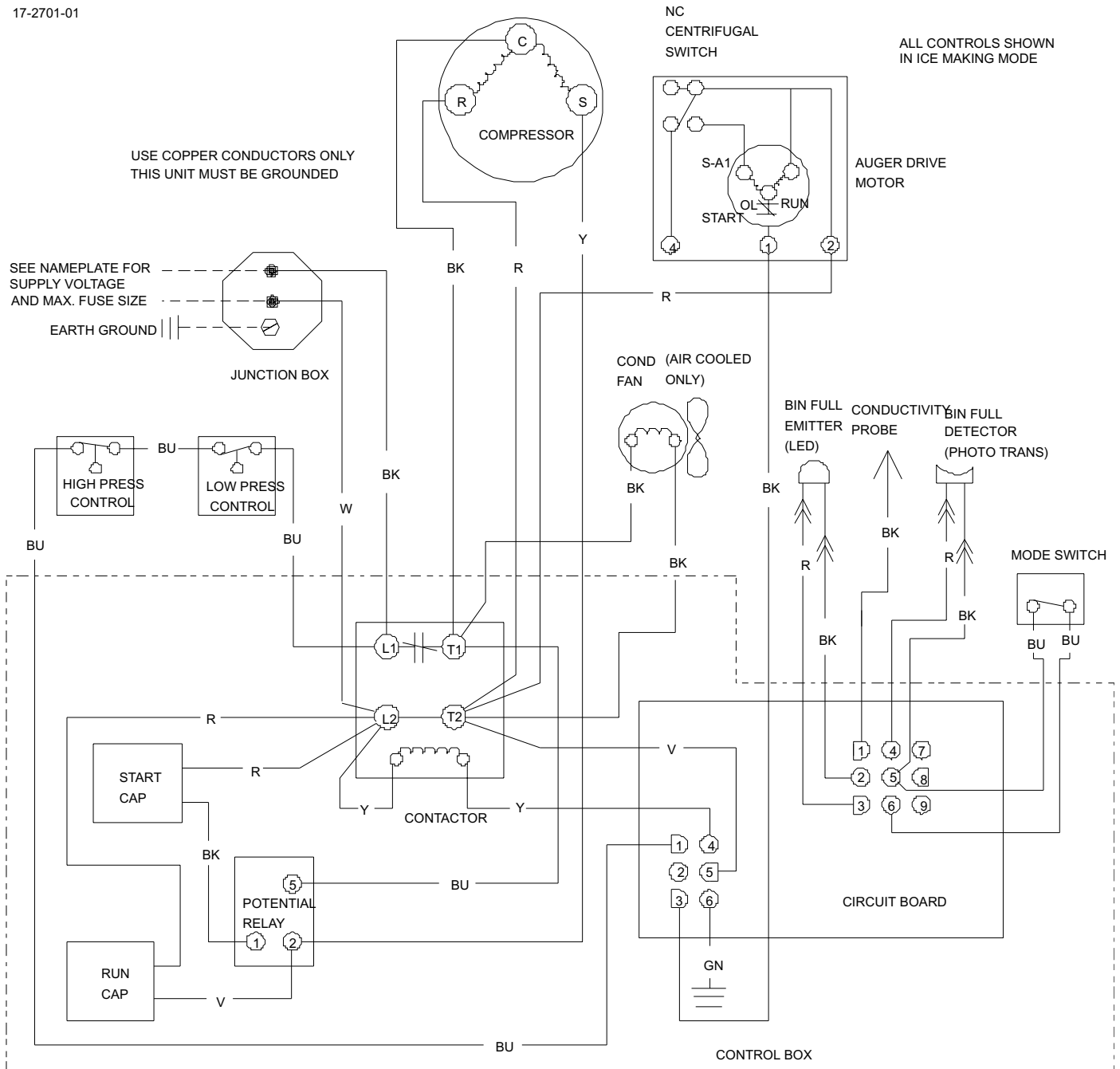

NSE654 SERVICE PARTS Schematic Diagram

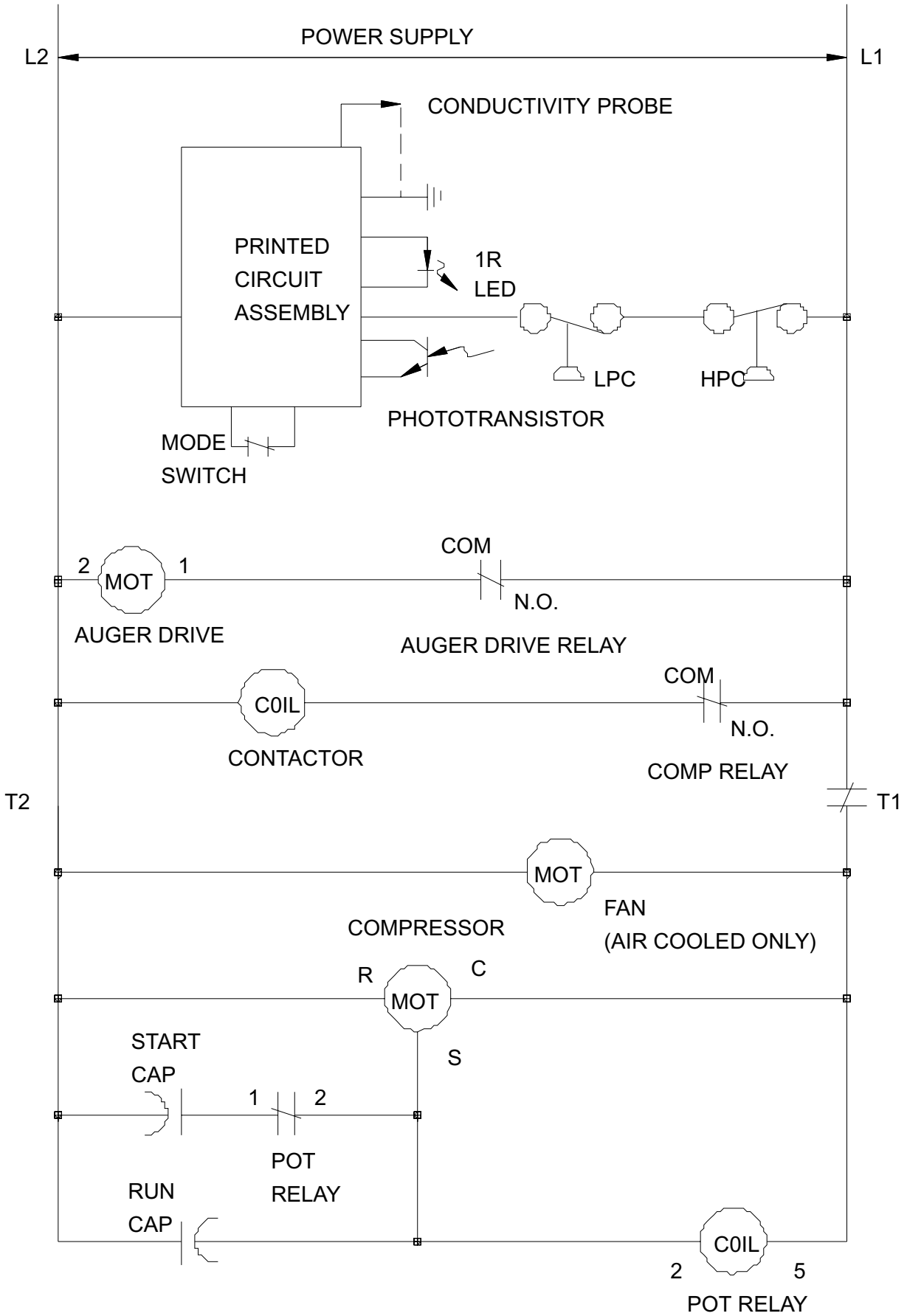

SCOTSMAN®

Bulletin Number: PS-14-96

Bulletin Date: September 1996

SERVICE BULLETIN

Subject: NME, FME, NSE, NDE and TDE550/650 Top Bearing Lubrication

Two parts have been made available as helpful aids to use when lubricating the top bearing.

1. **02-3559-01** is a needle that snaps onto a standard grease gun fitting. Use it to insert and deeply pack the proper lubricant into the top bearing.
2. **A36808-001** is a tube of the proper lubricant, also designed to fit a standard grease gun.

Both numbers are in the parts price list.

Needle, shown inserted into bearing

