

PO760 Parts List

Table of Contents

Cabinet I

Cabinet II

Air Cooled

Water Cooled

Water System

Evaporator

Spout

Gear Motor

Compressor

Valve Tower

Control Box - Air Cooled

Control Box - Water Cooled

Carbonator Tank

Carbonator Control

Wiring Diagrams

PO760 THE PARTS ILLUSTRATIONS AND PARTS LISTS

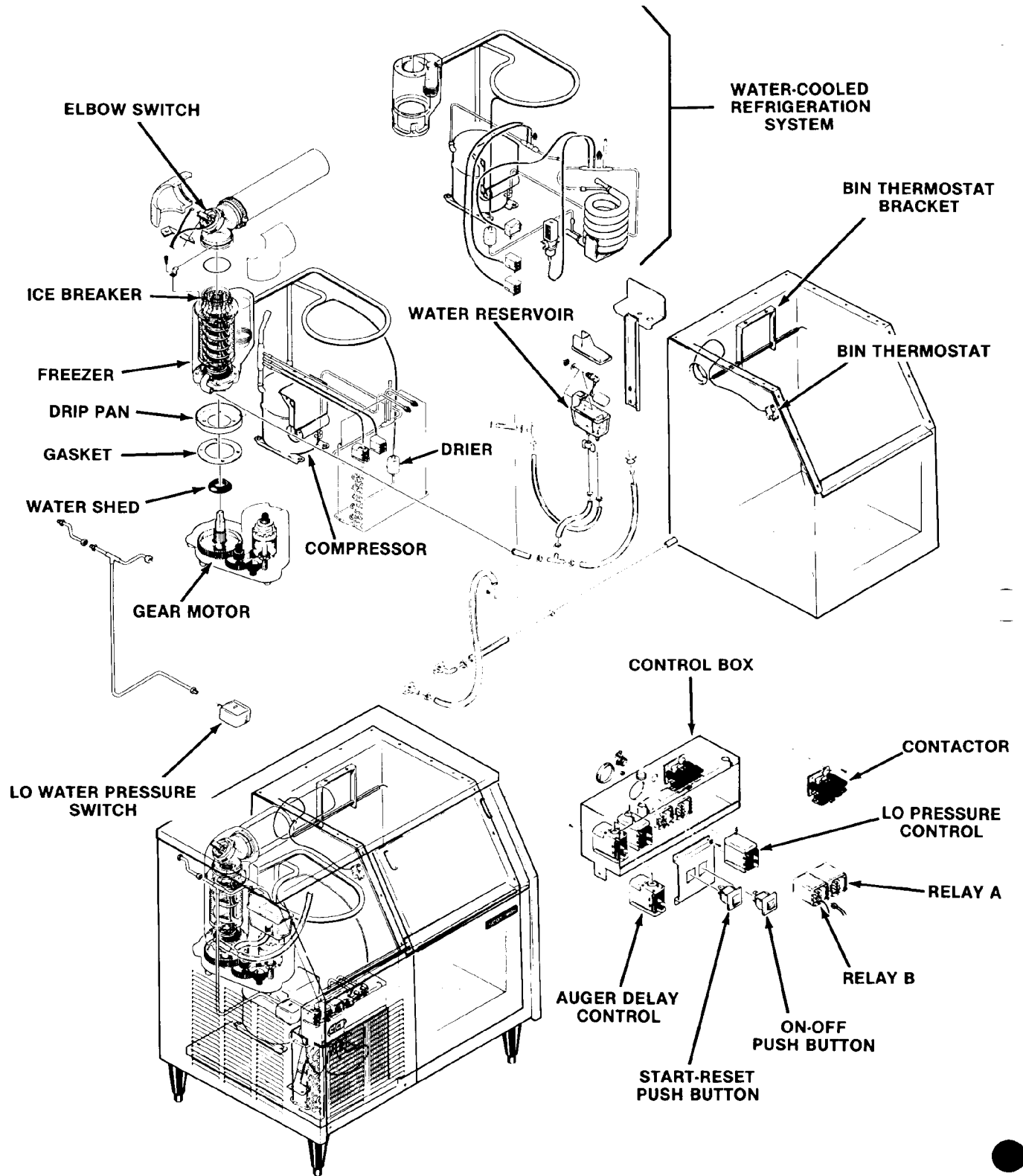

PO760 THE PARTS ILLUSTRATIONS AND PARTS LISTS

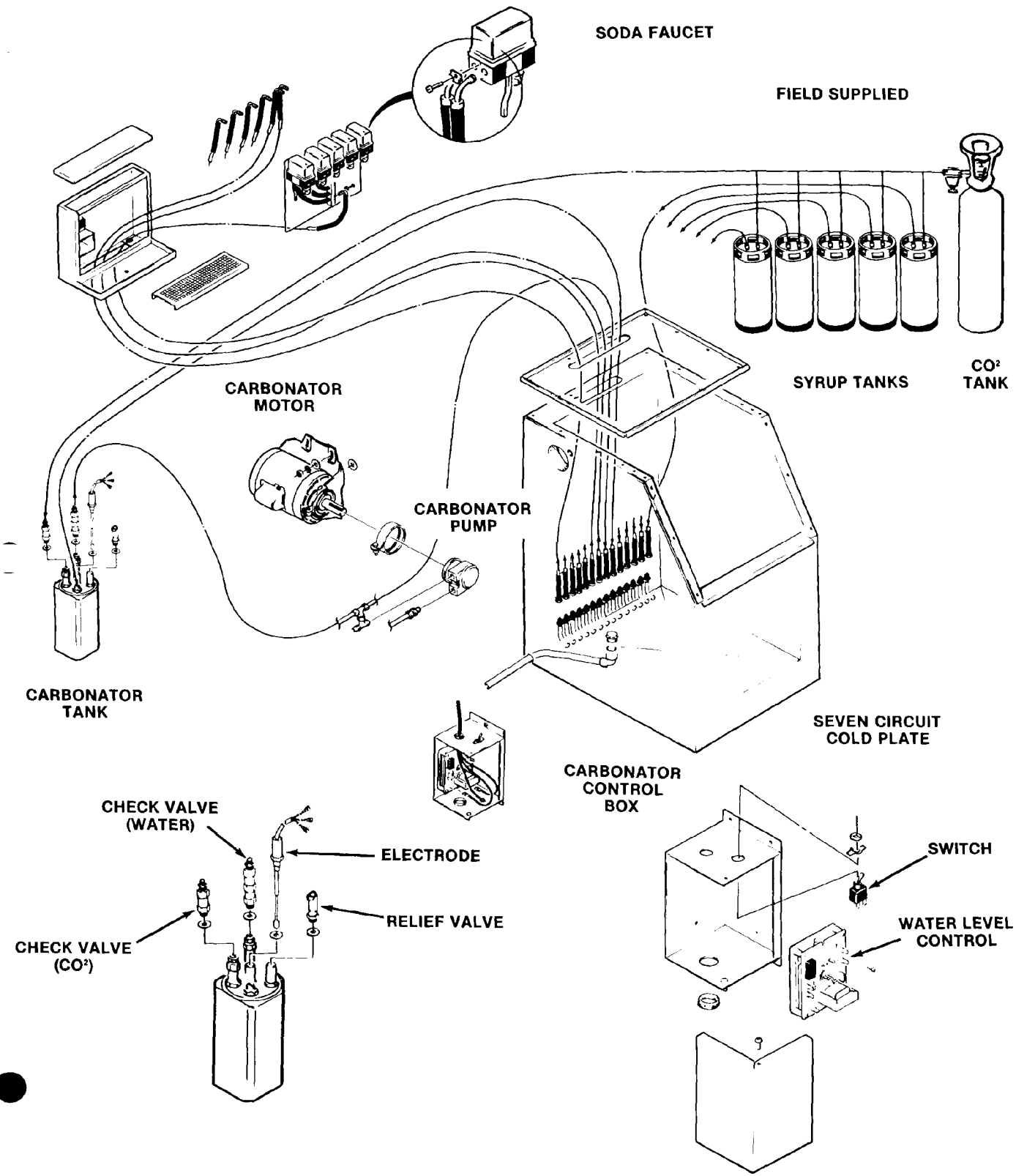

PO760 THE PARTS ILLUSTRATIONS AND PARTS LISTS

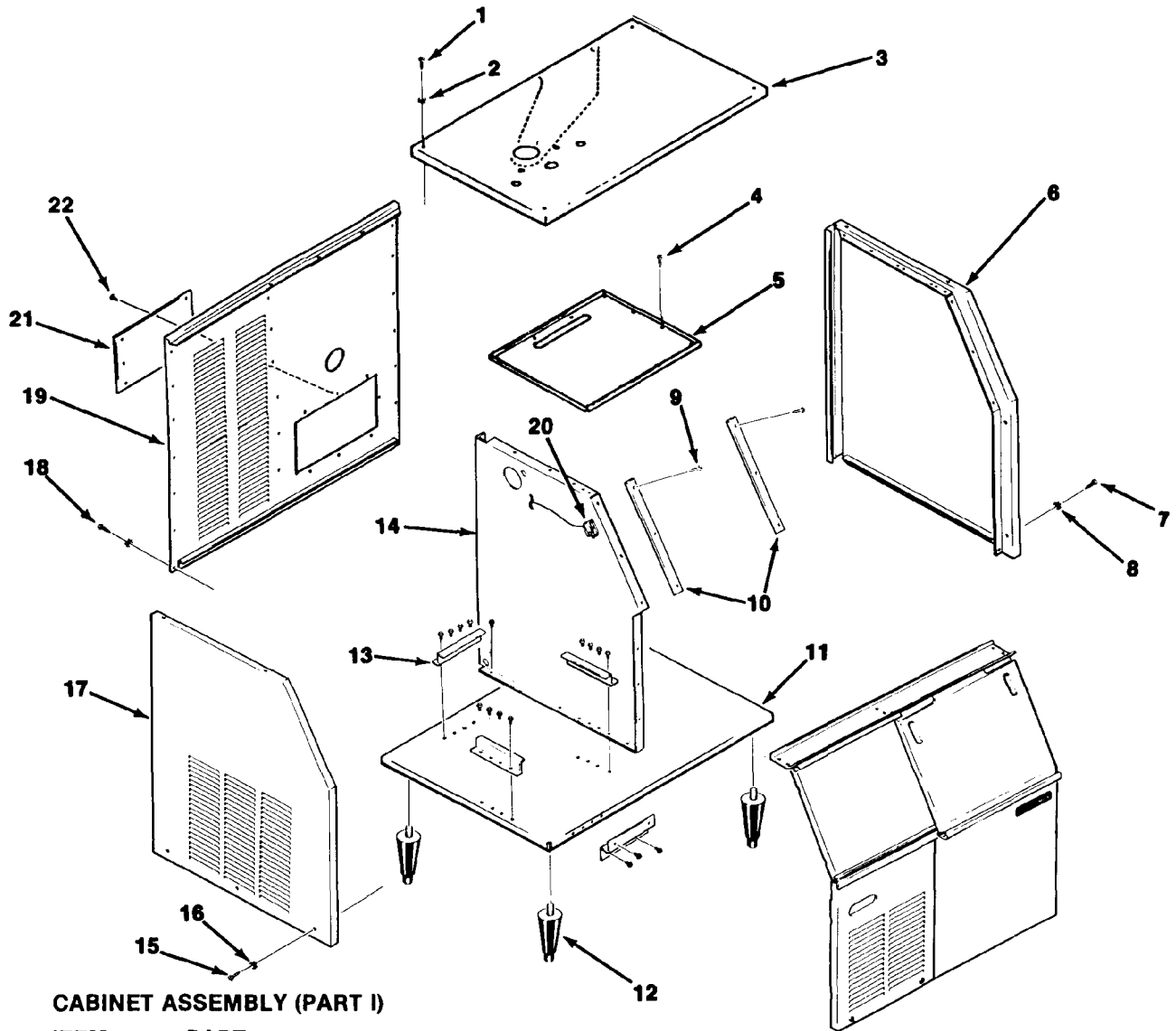

CABINET ASSEMBLY (PART I)

ITEM NUMBER	PART NUMBER	DESCRIPTION
1	03-1419-19	Screw, #8 x 1-3/4
2	03-1417-15	Lockwasher, #8
3	A30512-002	Top Panel, S.S. Only
4	03-1404-09	Screw, #8 x 1/2
5	A30722-001	Cover, Bin
6	A24800-007	Panel, Right Side
	A24800-002	Panel, Right Side S.S.
7	03-1404-09	Screw, #8 x 1/2
8	03-1417-03	Lockwasher, #8
9	03-1404-10	Screw
10	A30503-001	Support Strip, Right
	A30503-002	Support Strip, Left
	11	No Number Unit Base
	12	No Number Legs, Enamel (KLP2E)
		No Number Legs, S.S. (KLP2S)
	13	No Number Chassis Stop
	14	A27032-002 Insulation Retainer
	15	03-1404-09 Screw, #8 x 1/2
	16	03-1417-03 Lockwasher, #8
	17	A27034-007 Panel, Left Side Enamel
		A27034-002 Panel, Left Side S.S.
	18	03-1404-09 Screw
	19	A32322-002 Back Panel
	20	11-0354-00 Bin Thermostat
	21	A30507-001 Rear Cover Plate
	22	03-1531-03 Screw

PO760 THE PARTS ILLUSTRATIONS AND PARTS LISTS

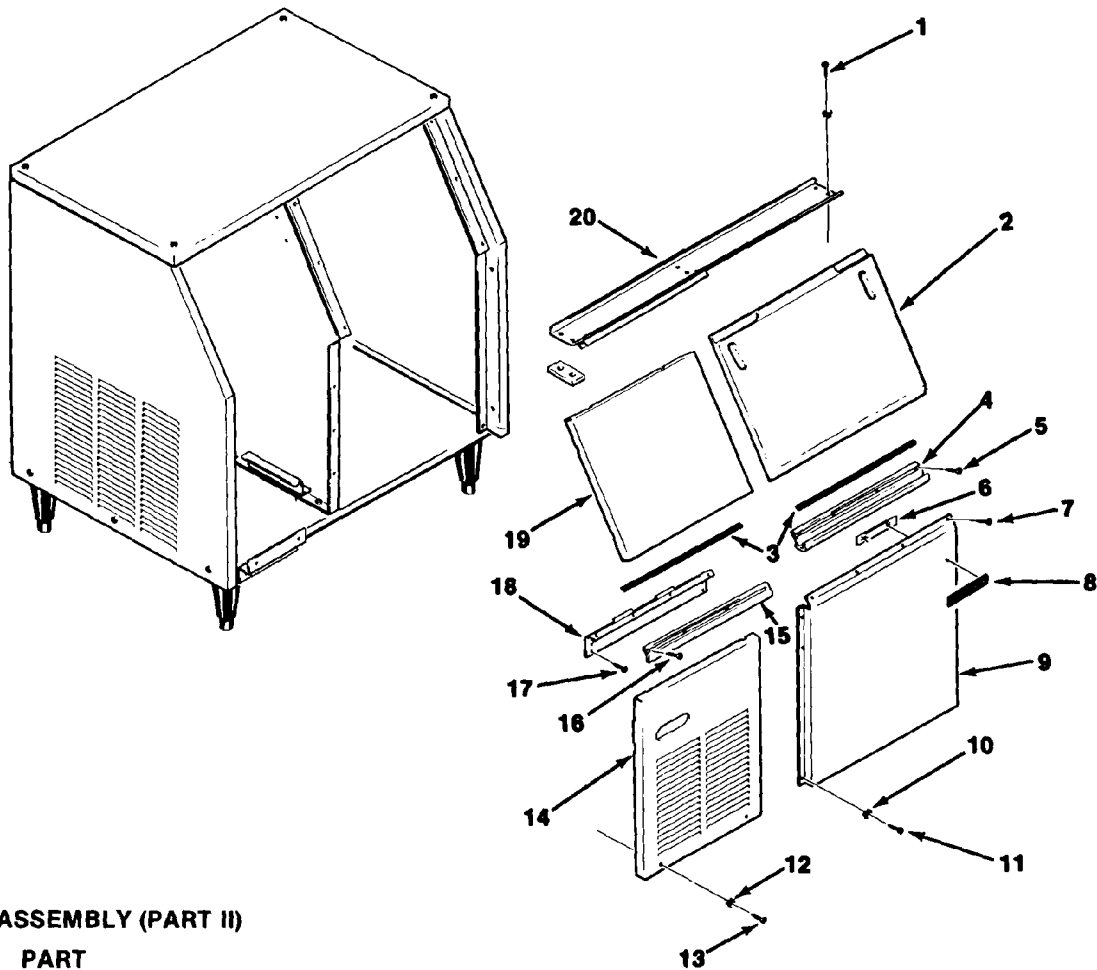

CABINET ASSEMBLY (PART II)

ITEM NUMBER	PART NUMBER	DESCRIPTION
1	03-1404-09	Screw, #8 x 1/2
2	02-2130-01	Ice Access Door, Enamel Units (orange plastic)
	02-2130-02	Ice Access Door, S.S. (grey plastic)
3	15-0324-00	Plastic Insert (36.5")
4	15-0620-01	Moulding Strip
5	03-1419-05	Screw, #8 x 5/8
6	03-0271-00	Speed Clip
7	03-1419-05	Screw, #8 x 1-1/2
8	15-0711-01	Scotsman Emblem
9	A24794-007	Panel, Right Front Enamel
	A24794-002	Panel, Right Front S.S.
10	03-1417-03	Lockwasher
	11	03-1404-09 Screw, #8 x 1/2
	12	03-1417-15 Lockwasher, #8
	13	03-1419-16 Screw, #8 x 1/2
	14	A30496-004 Panel, Lower Left Front, Enamel
	A30496-002	Panel, Lower Left Front, S.S.
	15	15-0706-01 Moulding Strip
	16	03-1419-05 Screw
	17	03-1404-09 Screw, #8 x 1/2
	18	A30502-001 Bracket, Left Front
	19	A30497-005 Panel, Upper Left Front, Enamel
	A30497-002	Panel, Upper Left Front, S.S.
	20	A30539-001 Door Track Assembly

PO760 THE PARTS ILLUSTRATIONS AND PARTS LISTS

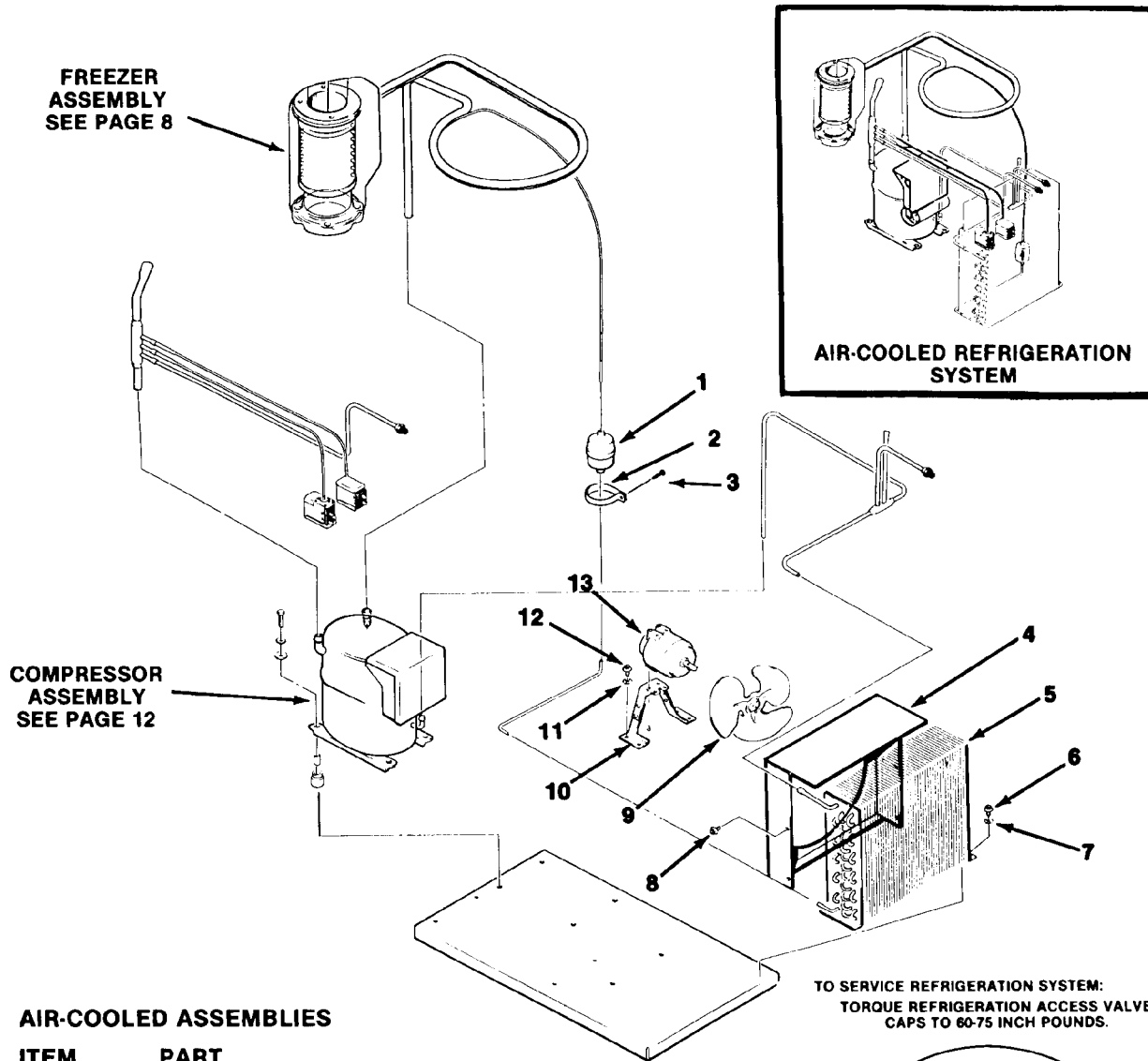

AIR-COOLED ASSEMBLIES

ITEM NUMBER	PART NUMBER	DESCRIPTION
1	02-0544-01	Drier
2	A09388-001	Drier Brace
3	03-1531-01	Screw, #8 x 7/8
4	A30003-001	Shroud
5	18-0396-01	Condenser
6	03-0571-00	Screw, 1/4 - 20 x 1/2
7	03-1417-09	Lockwasher, 1/4
8	03-1404-03	Screw, #6 x 1/4
9	18-0625-00	Fan Blade
10	A25548-001	Fan Mounting Bracket
11	03-1417-09	Lockwasher, 1/4
12	03-0571-00	Screw, 1/4 - 20 x 1/2
13	18-0559-01	Fan Motor 115/60/1

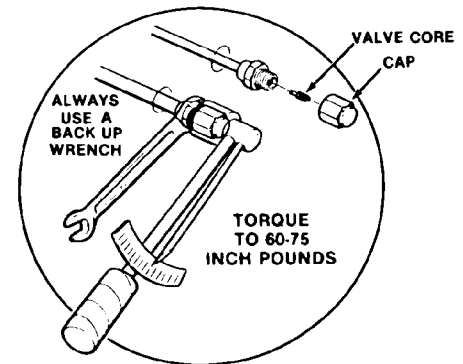

ALWAYS USE A BACK-UP WRENCH TO AVOID DAMAGE TO THE REFRIGERANT TUBING.

PO760 THE PARTS ILLUSTRATIONS AND PARTS LISTS

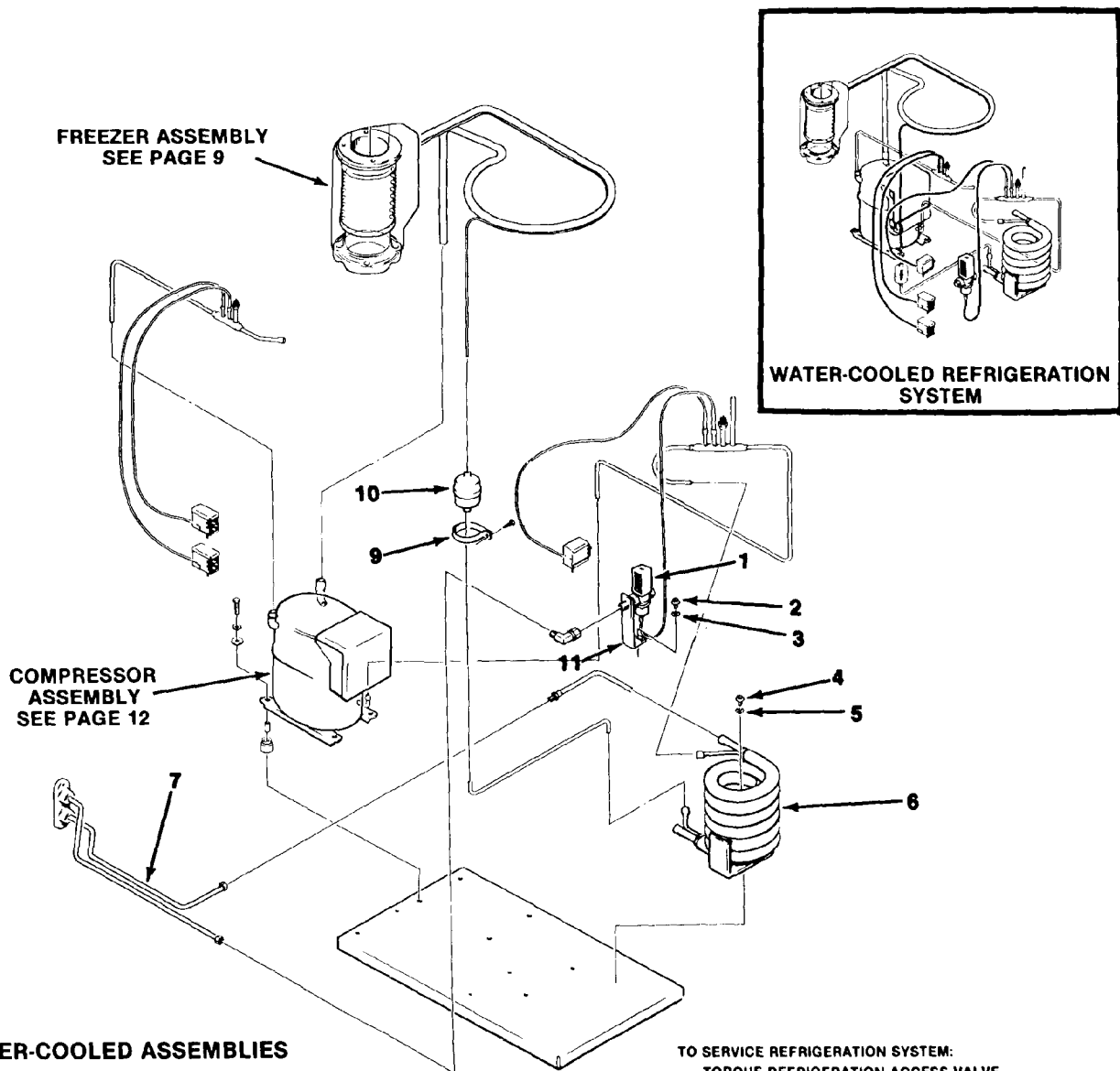

WATER-COOLED ASSEMBLIES

ITEM NUMBER	PART NUMBER	DESCRIPTION
1	11-0198-02	Water Regulator Assembly
2	03-0571-00	Screw, 1/4 - 20 x 1/2
3	03-1417-09	Lockwasher, 1/4
4	03-0571-00	Screw, 1/4 - 20 x 1/2
5	03-1417-09	Lockwasher, 1/4
6	18-3305-02	Condenser
7	A32092-001	Drain Assembly, Water-Cooled
8	03-1531-01	Screw, #8 x 7/8
9	A09388-001	Brace
10	02-0544-01	Drier
11	A15924-000	Bracket

TO SERVICE REFRIGERATION SYSTEM:
TORQUE REFRIGERATION ACCESS VALVE
CAPS TO 60-75 INCH POUNDS.

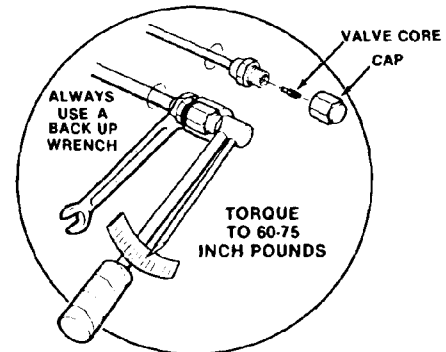

ALWAYS USE A BACK-UP
WRENCH TO AVOID DAMAGE
TO THE REFRIGERANT TUBING.

PO760 THE PARTS ILLUSTRATIONS AND PARTS LISTS

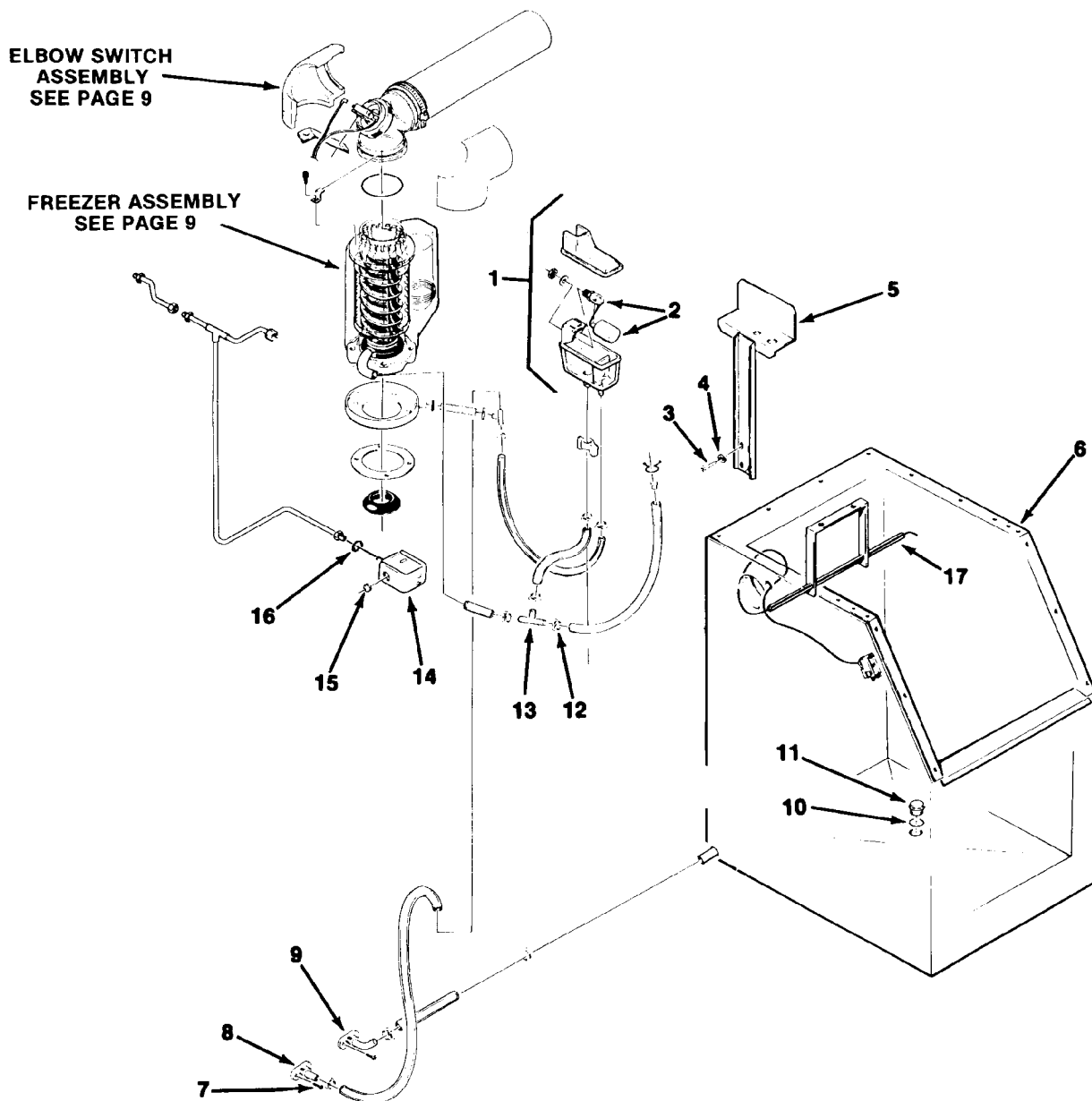

WATER AND DRAINAGE SYSTEM

ITEM NUMBER	PART NUMBER	DESCRIPTION			
1	02-2217-01	Reservoir	9	A32088-001	Drain Assembly
2	02-2217-02	Valve and Float	10	13-0617-11	O-ring
3	03-0571-00	Screw, 1/4 - 20 x 1/2	11	02-2809-01	Drain Top
4	03-1417-09	Lockwasher, 1/4	12	02-0534-00	Hose Clamp
5	A30538-001	Reservoir Bracket	13	16-0670-02	Tee
6	A30464-001	Storage Bin	14	11-0296-00	Lo Water Pressure Control
7	03-1405-03	Screw, 1/4 - 20 x 1/2	15	12-1213-10	Snap Bushing
8	A32091-001	Drain Assembly (Water-Cooled only)	16	No Number	Rubber Washer
			17	A30720-001	Bin Thermostat Bracket

PO760 THE PARTS ILLUSTRATIONS AND PARTS LISTS

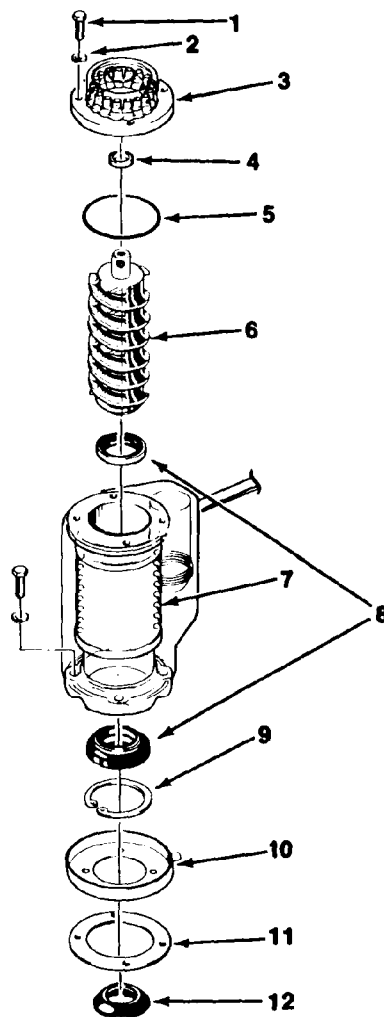
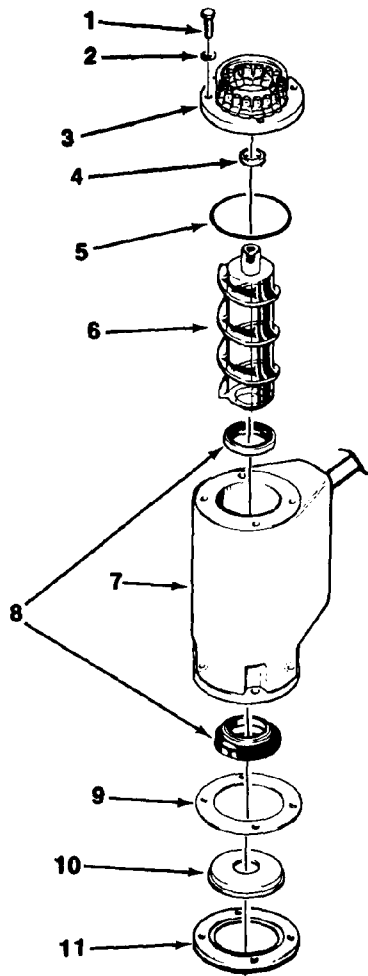

FREEZER ASSEMBLY (A & B MODELS ONLY)

ITEM NUMBER	PART NUMBER	DESCRIPTION
1	03-1405-42	Screw, No. 5/16 - 18 x 7/8 Hex Cap
2	03-1417-13	Lockwasher, No. 5/16 Helical Spring
3	A32571-020	Ice Breaker (Includes Bearing & Seal)
4	02-2853-01	Seal
5	13-0617-46	O-Ring
6	A31839-001	Auger
7	A32098-020	Freezer Assembly
8	02-0929-01	Seal, Water
9	13-0704-00	Gasket
10	A29463-001	Adapter Freezer
11	02-2577-01	Adapter Large

FREEZER ASSEMBLY (C MODEL ONLY)

ITEM NUMBER	PART NUMBER	DESCRIPTION
1	03-1405-42	Screw
2	03-1417-13	Lockwasher
3	A32571-020	Ice Breaker (Includes Bearing & Seal)
4	02-2853-01	Seal
5	13-0617-46	O-Ring
6	A31839-001	Auger
7	A32098-020	Freezer Assembly (Includes 9, 10, 11 & 12)
8	02-0929-01	Water Seal
9	03-1558-05	Snap Ring
10	A32050-001	Drip Pan
11	13-0704-00	Gasket
12	13-0709-02	Water Shed

PO760 THE PARTS ILLUSTRATIONS AND PARTS LISTS

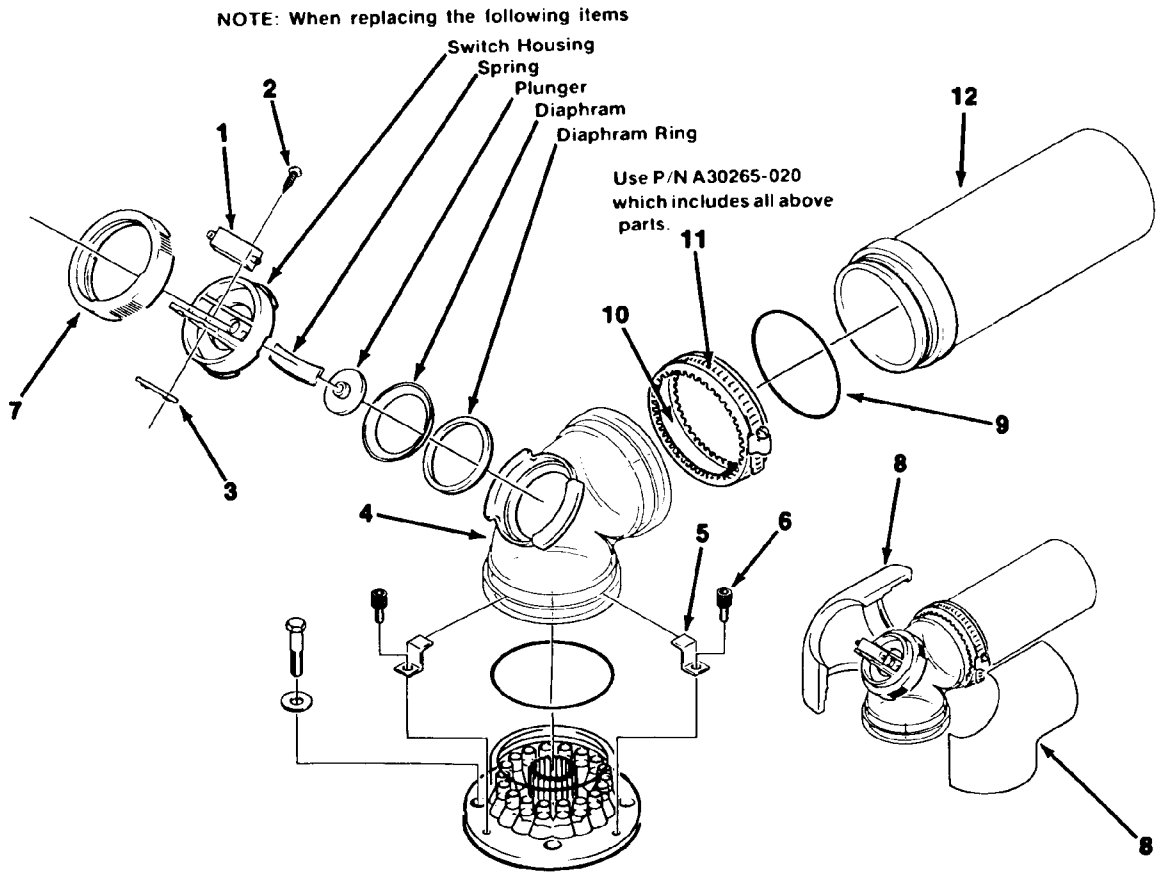

ELBOW AND SWITCH ASSEMBLY

ITEM NUMBER	PART NUMBER	DESCRIPTION
1	12-2202-01	Switch
2	03-1403-08	Screw, No. 6-32 x 7/8
3	03-0886-00	Speednut
4	02-2764-01	Elbow Assembly
5	02-2604-01	Bracket, Spout Retaining
6	03-1544-04	Screw, No. 10-24 x 3/8 S.S. Soc Hd Cap
7	02-2637-01	Retaining Ring
8	A31390-001	Insulation (Includes left & right sides)
9	13-0619-49	O-Ring
10	A30089-001	U-Channel
11	02-0179-03	Clamp
12	A30087-004	Ice Tube

PO760 THE PARTS ILLUSTRATIONS AND PARTS LISTS

DRIVE MOTOR ASSEMBLY

ITEM NUMBER	PART NUMBER	DESCRIPTION
1	02-1606-00	Oil Seal
2	13-0709-02	Water Shed C Model Only
3	02-2853-01	Oil Seal Top - Faces Up
4	03-1251-01	Screw*
5	A31230-001	Gear Case Cover Assembly*
6	02-1681-00	Thrust Race
7	03-1363-00	Retaining Ring
8	02-2541-01	Shaft, Output
9	03-1630-01	Key
10	02-2745-01	Gear, Output
11	02-1604-00	Third Pinion Assembly, Second Gear
12	02-1679-00	Thrust Race
13	A32368-020	Bearing (Includes Items 12, 13, & 14)
14	02-1679-00	Thrust Race
15	A26103-001	"O" Ring
16	A31230-001	Gear Case Assembly Bottom*
17	03-1408-24	Washer
18	02-1603-00	Second Pinion Assembly, First Gear
19	03-1408-24	Washer
20	12-1741-29	Bearing Shaft GE
	12-1741-20	Bearing Shaft Emerson
	12-2314-20	GE P.S.C.
21	A32425-001	Drive Motor
22	12-1741-28	Switch, Start (General Electric) #1
	12-1741-32	Start Switch (General Electric) #2
	12-2314-21	Centrifugal Switch P.S.C.
	12-1741-22	Switch, Start (Emerson)
23	A25835-001	Gearcase Oil (1) Pint
24	A32404-021	Gearmotor Assembly Complete
25	12-2314-22	Capacitor (G.E. PSC Only)

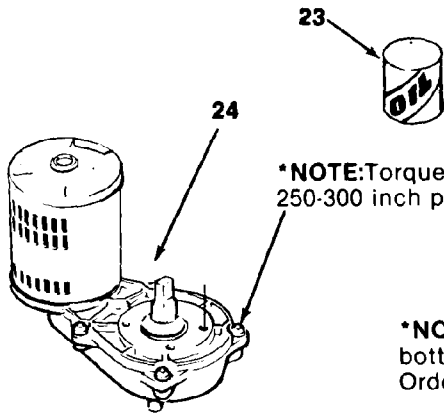
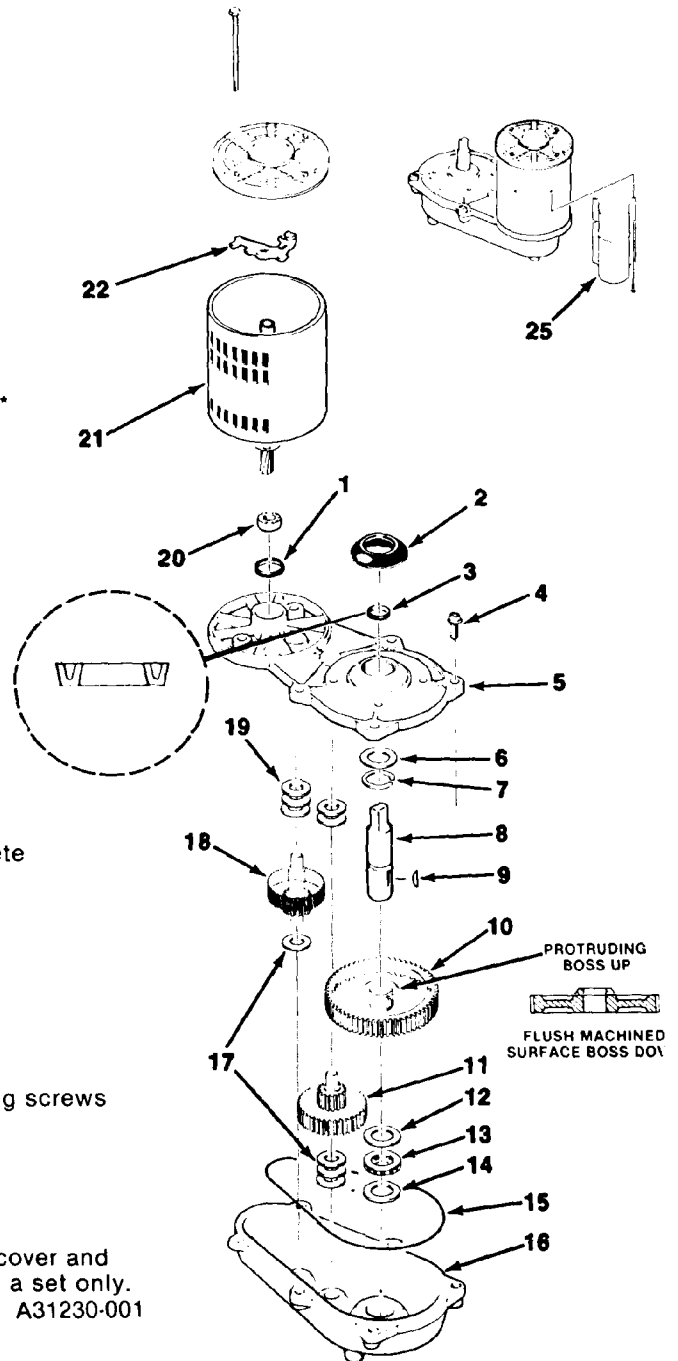

*NOTE: Torque cover mounting screws 250-300 inch pounds.

*NOTE: Gearcase cover and bottom are sold as a set only. Order Part Number A31230-001

PO760 THE PARTS ILLUSTRATIONS AND PARTS LISTS

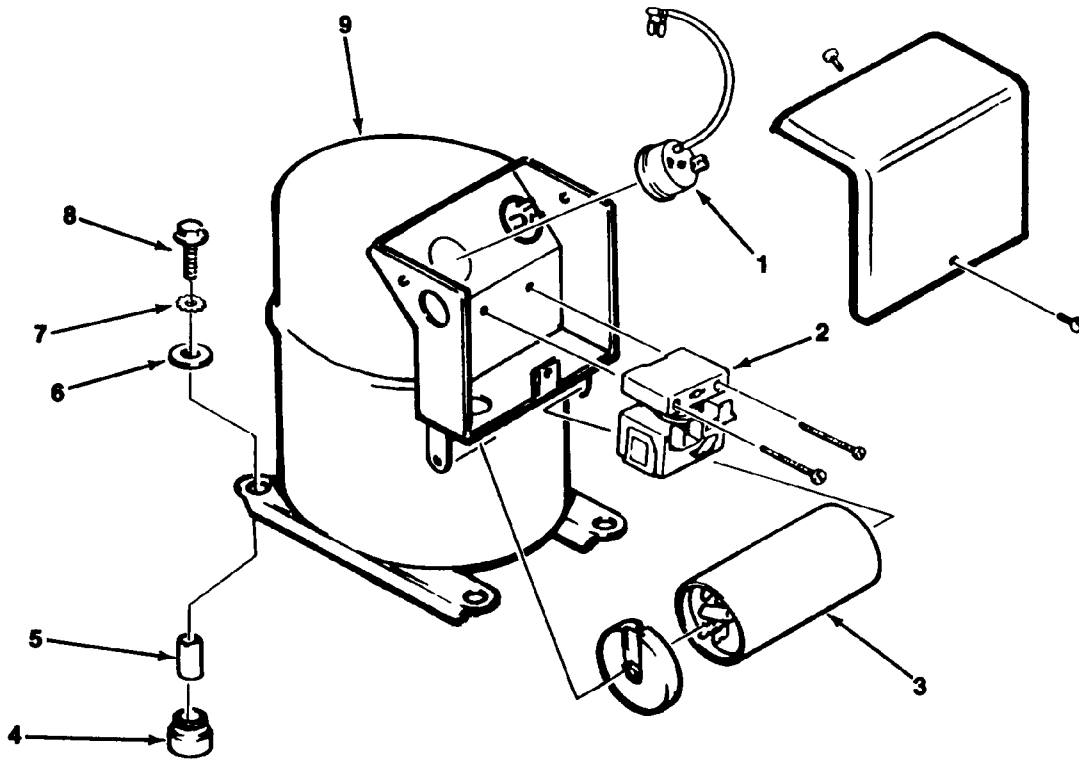

COMPRESSOR ASSEMBLY

ITEM NUMBER	PART NUMBER	DESCRIPTION
1	18-2400-25	Overload (115/60/1)
2	18-2410-00	Relay (115/60/1)
3	18-2420-00	Capacitor with cap, (115/60/1)
4	18-2200-28	Grommet
5	18-2200-27	Sleeve
6	03-1408-29	Washer
7	03-1417-12	Lockwasher
8	03-1405-40	Screw
9	18-3900-01	Compressor Assembly, (115/60/1)

PO760 THE PARTS ILLUSTRATIONS AND PARTS LISTS

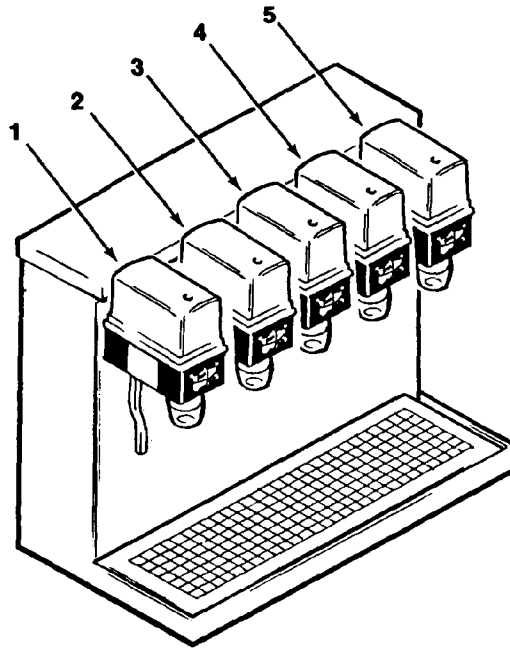

Post-Mix Soda Valves for KDT1 Dispense Tower

Complete Post-Mix Soda Valves are available for the KDT1 Dispense Tower. Refer to the illustration and parts listing below for the correct Part Number.

Valve No.	#1, #2, #3	#4	#5
Scotsman No.	11-0434-01	11-0434-02	11-0434-03
McCann No.	24-1108	12-1208	12-1207

NOTE: Individual Internal Replacement Parts aren't furnished by Scotsman. Parts may be purchased direct from the McCann Factory:

McCann's Engineering & Mfg. Co.
 2570 Colorado Blvd.
 Los Angeles, CA 90039

PO760 THE PARTS ILLUSTRATIONS AND PARTS LISTS

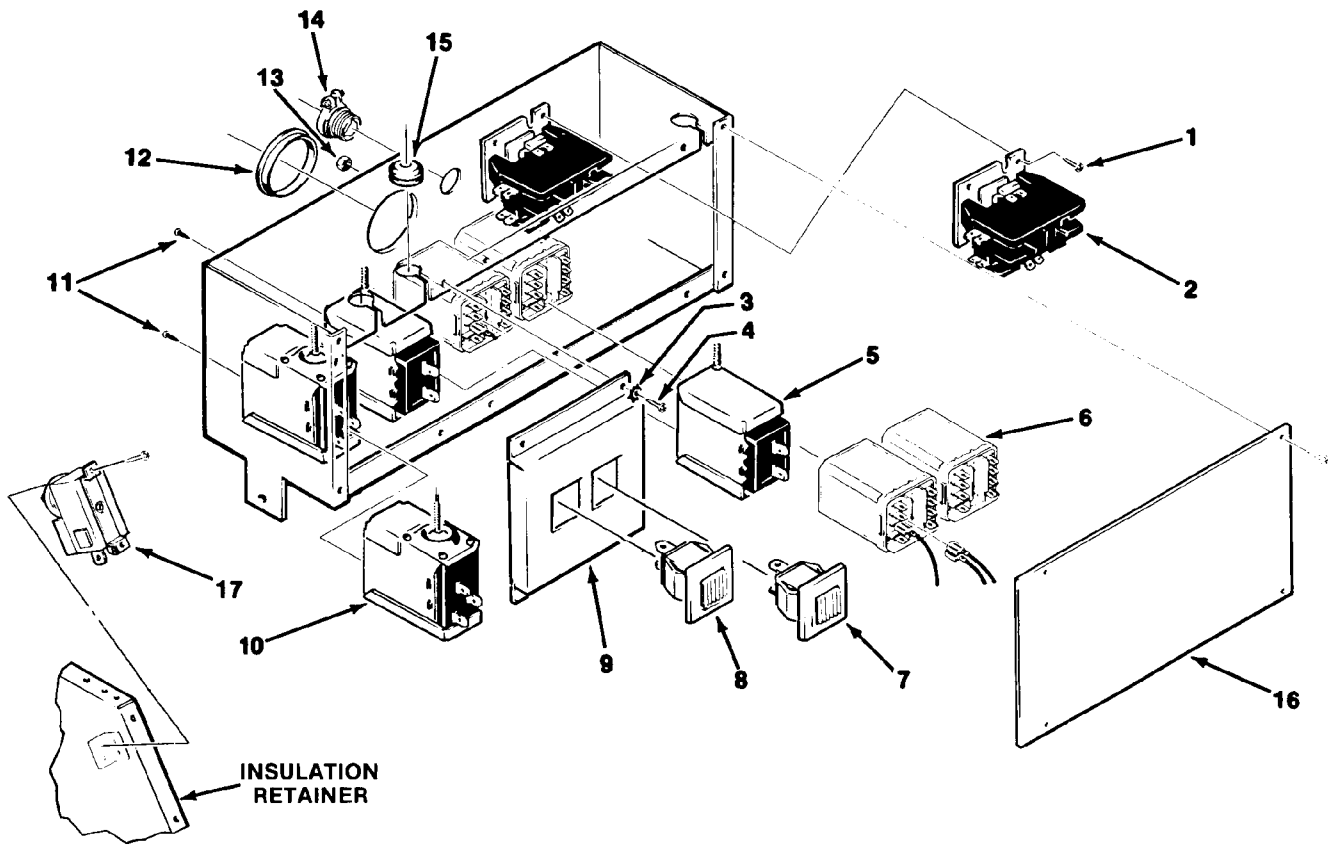

CONTROL BOX ASSEMBLY - AIR-COOLED

ITEM NUMBER	PART NUMBER	DESCRIPTION
1	03-1531-01	Screw, #8 x 3/8
2	12-2048-01	Contactora, (115/60/1)
3	03-1417-03	Lockwasher
4	03-1531-01	Screw, #8 x 3/8
5	11-0402-01	Lo Pressure Control (Auger Delay)
6	12-2090-01	Relay, (115/60/1)
7	12-2200-01	ON-OFF Switch, (115/60/1)
8	12-2199-01	Start-Reset Switch, (115/60/1)
9	A30543-001	Switch Housing
10	11-0420-01	Low Pressure Control
11	03-1403-02	Screw, #6 x 1/4
12	12-1213-12	Snap Bushing
13	03-1406-01	Nut
14	12-0256-00	Straight Connector
15	13-0557-00	Grommet
16	A31654-001	Control Box Cover
17	11-0354-00	Bin Thermostat (Located on Insulation Retainer)

PO760 THE PARTS ILLUSTRATIONS AND PARTS LISTS

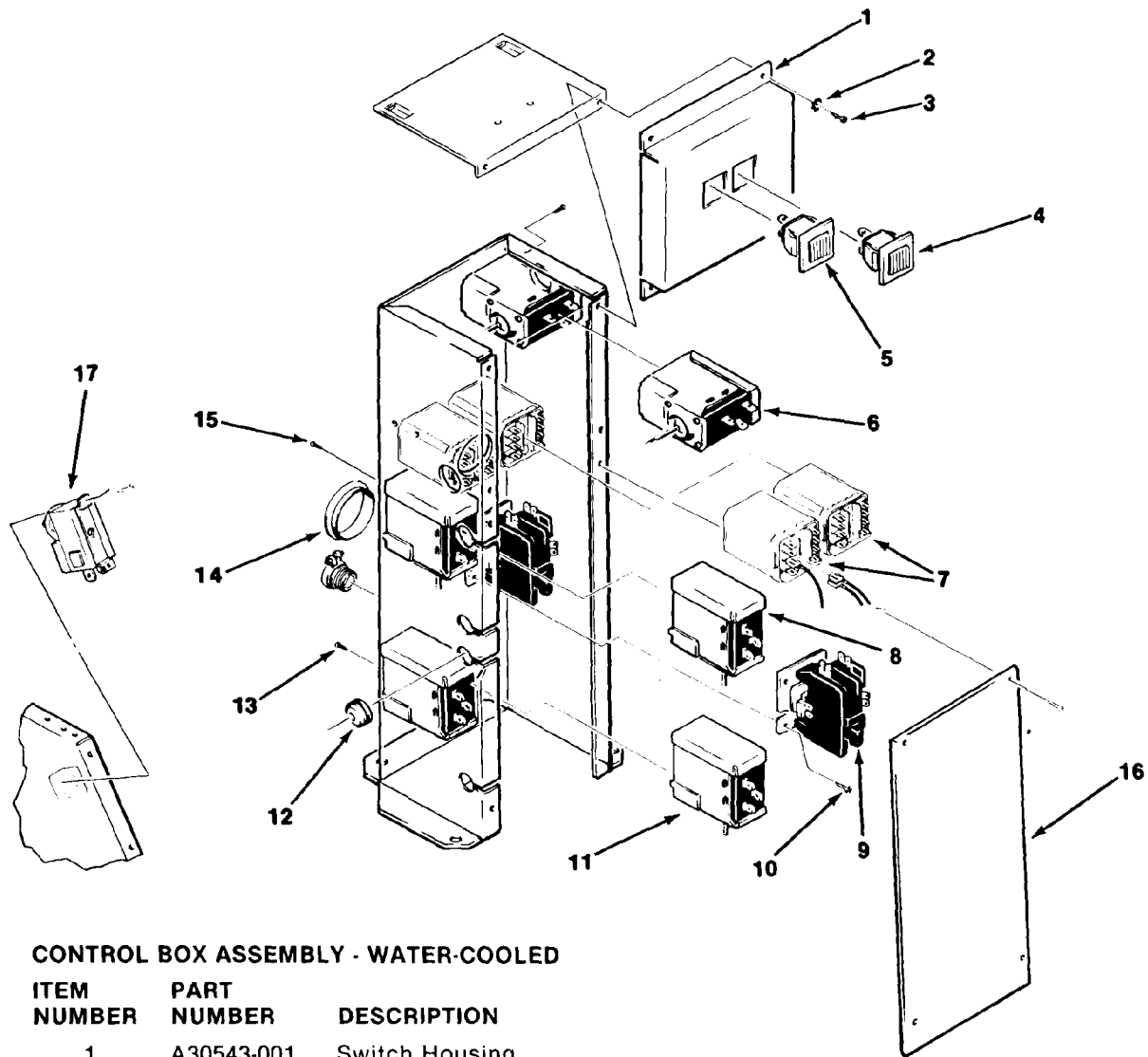

CONTROL BOX ASSEMBLY - WATER-COOLED

ITEM NUMBER	PART NUMBER	DESCRIPTION
1	A30543-001	Switch Housing
2	03-1417-03	Lockwasher
3	03-1531-01	Screw, #8 x 3/8
4	12-2200-01	ON-OFF Switch, (115/60/1)
5	12-2199-01	Start-Reset Switch, (115/60/1)
6	11-0388-02	Hi Pressure Control
7	12-2090-01	Relay, (115/60/1)
8	11-0402-01	Auger Delay - Control
9	12-2048-01	Contactor, (115/60/1)
10	03-1531-01	Screw, #8 x 3/8
11	11-0420-01	Low Pressure Control
12	13-0557-00	Grommet
13	03-1403-02	Screw, #6 x 1/4
14	12-1213-10	Snap Bushing
15	03-1413-02	Screw, #6 x 1/4
16	A30542-001	Control Box Cover
17	11-0354-00	Bin Thermostat (Located on Retainer)

PO760 THE PARTS ILLUSTRATIONS AND PARTS LISTS

CARBONATOR TANK (ORIGINAL)

- A — Carbonated Water Out
 - B — CO² Gas In
 - C — Water In
 - D — Relief Valve
- } FEMALE FITTING

ITEM NUMBER	PART NUMBER	DESCRIPTION
1	02-1916-07	Electrode
2	02-1916-04	Valve Double Check Water
3	02-1916-03	Valve, Relief
4	02-1916-02	Gasket (Used With Items 1, 2, 3 & 5)
5	02-1916-05	Valve, CO ² Check
6	A30694-020	Complete Carb Tank Assy

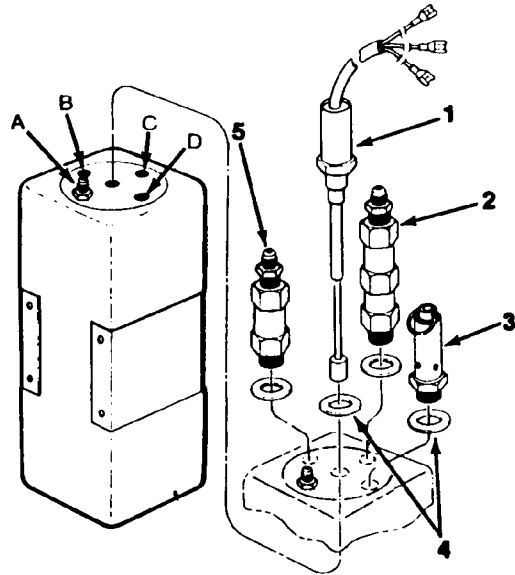

CARBONATOR TANK (NEW DESIGN)

- A — Carbonated Water Out
 - B — CO² Gas In
 - C — Water In
 - D — Relief Valve
- } MALE FITTING

ITEM NUMBER	PART NUMBER	DESCRIPTION
1	02-1916-07	Electrode
2	02-1916-09	Valve, Double Check (Water)
3	02-1916-08	Valve, Relief
4	02-1916-02	Gasket (Used With Items 1, 2, 3 & 5)
5	02-1916-10	Valve, CO ² Check
6	A30694-020	Complete Carb Tank Assy

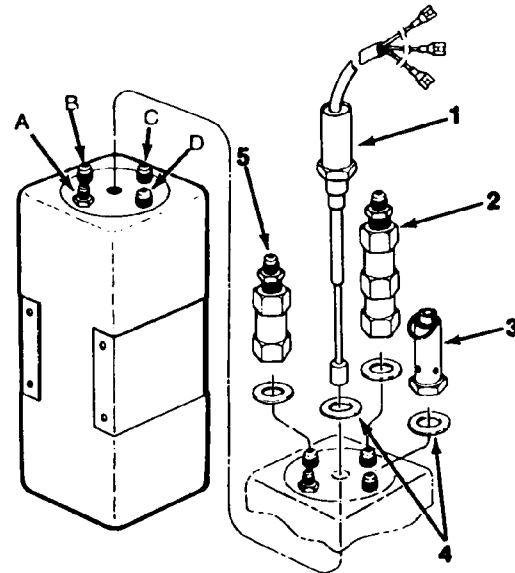

CARBONATOR PUMP ASSEMBLY

ITEM NUMBER	PART NUMBER	DESCRIPTION
1	A30687-001	Pump Plate
2	03-1407-07	Washer
3	03-1410-04	Lockwasher, 5/16
4	03-1406-10	Nut, 5/16-18
5	02-1527-00	Coupling Clamp
6	02-1526-00	Pump
7	No Number	Half Union
8	No Number	Tee
9	12-1339-01	Motor

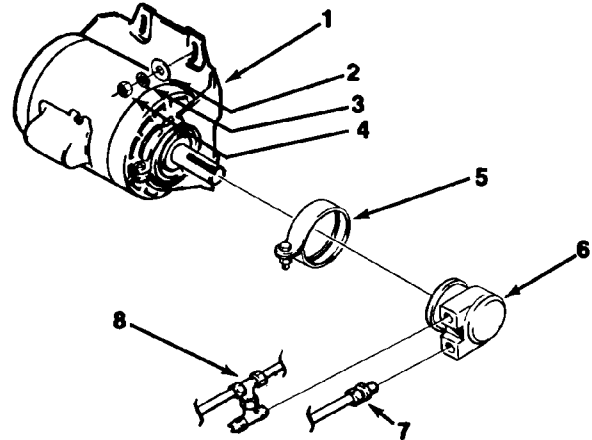

PO760 THE PARTS ILLUSTRATIONS AND PARTS LISTS

CARBONATOR CONTROL BOX ASSEMBLY

ITEM NUMBER	PART NUMBER	DESCRIPTION
1	12-0426-01	Toggle Switch
2	11-0384-01	Water Level Control
3	03-1403-04	Screw 6-32 x 3/8
4	12-1213-17	Snap Bushing
5	03-1578-01	Ground Screw

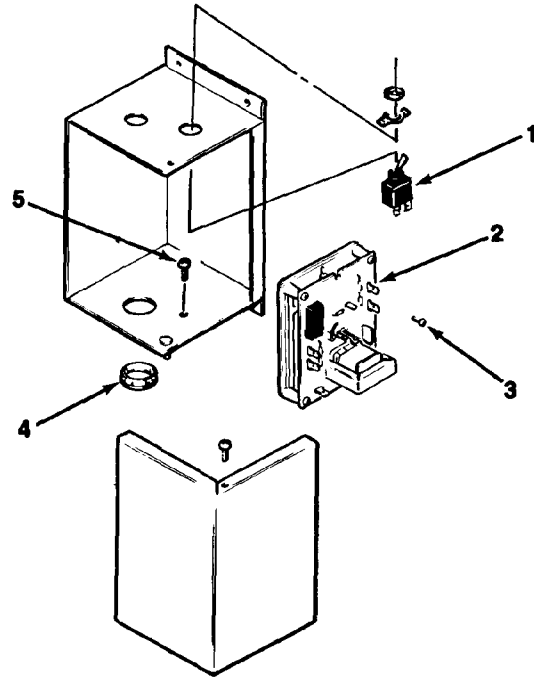

Control Box Assembly — Carbonation System

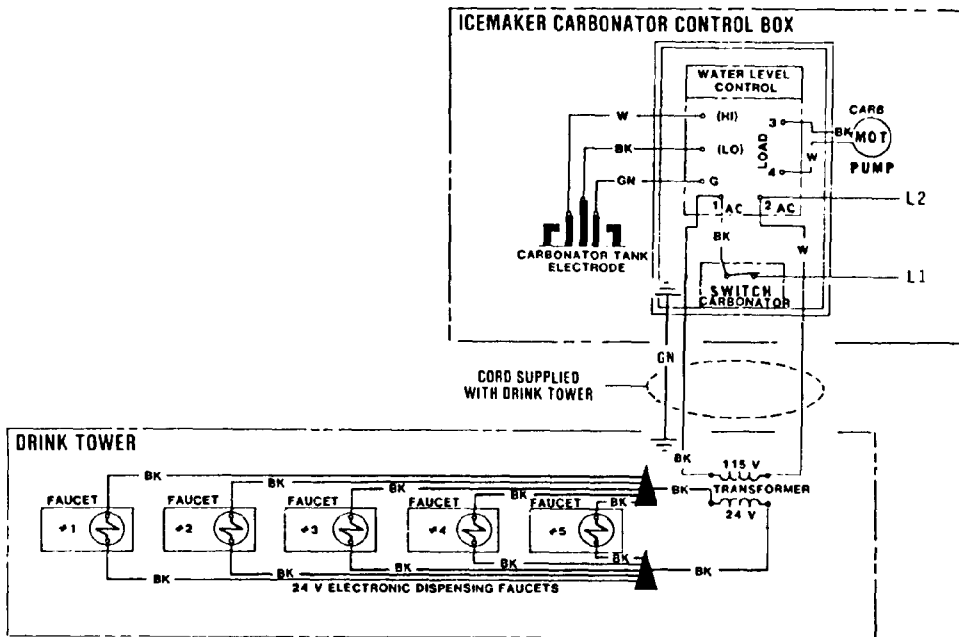

Wiring Diagram — Carbonation System

PO760 WIRING DIAGRAM

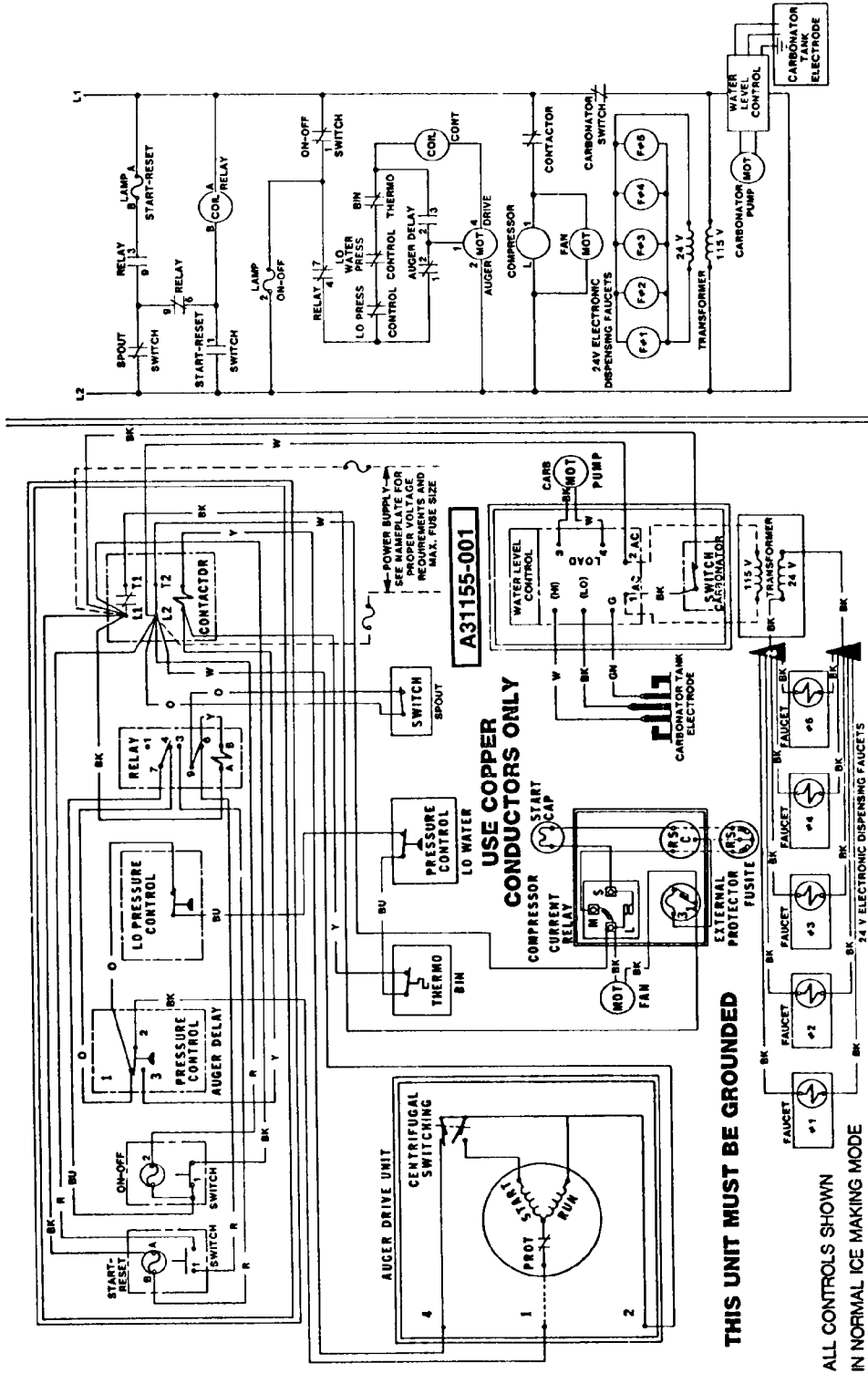

Wiring Diagram PO760AE-1A (115/60/1) Air-Cooled

PO760 WIRING DIAGRAM

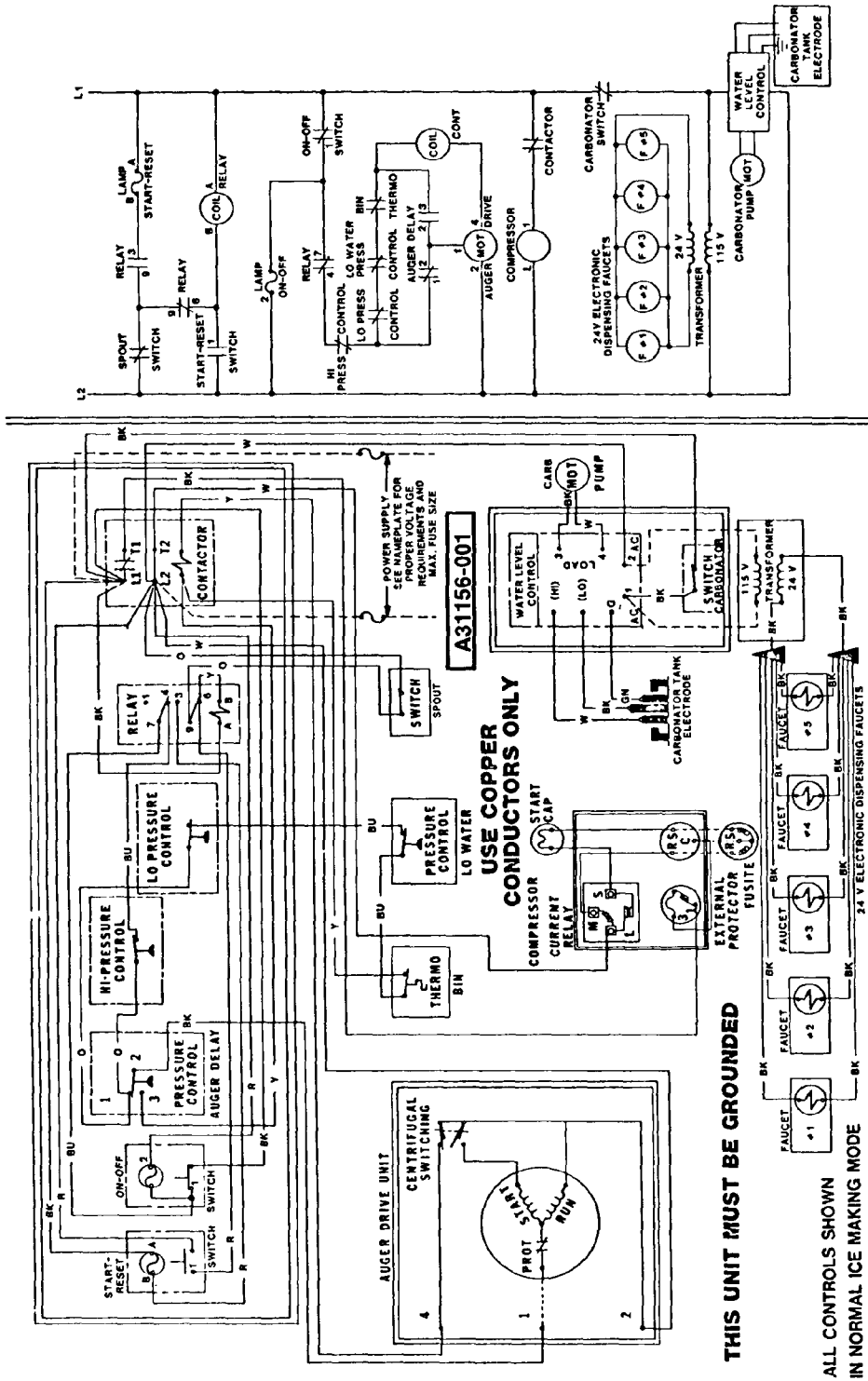

Wiring Diagram PO760WE-1A (115/60/1) Water-Cooled

