

PR760 Parts List

Table of Contents

Cabinet I

Cabinet II

Air Cooled

Water Cooled

Water System

Evaporator

Spout

Gear Motor

Valve Tower

Compressor

Control Box - Air Cooled

Control Box - Water Cooled

Wiring Diagrams

PR760 THE PARTS ILLUSTRATIONS AND PARTS LISTS

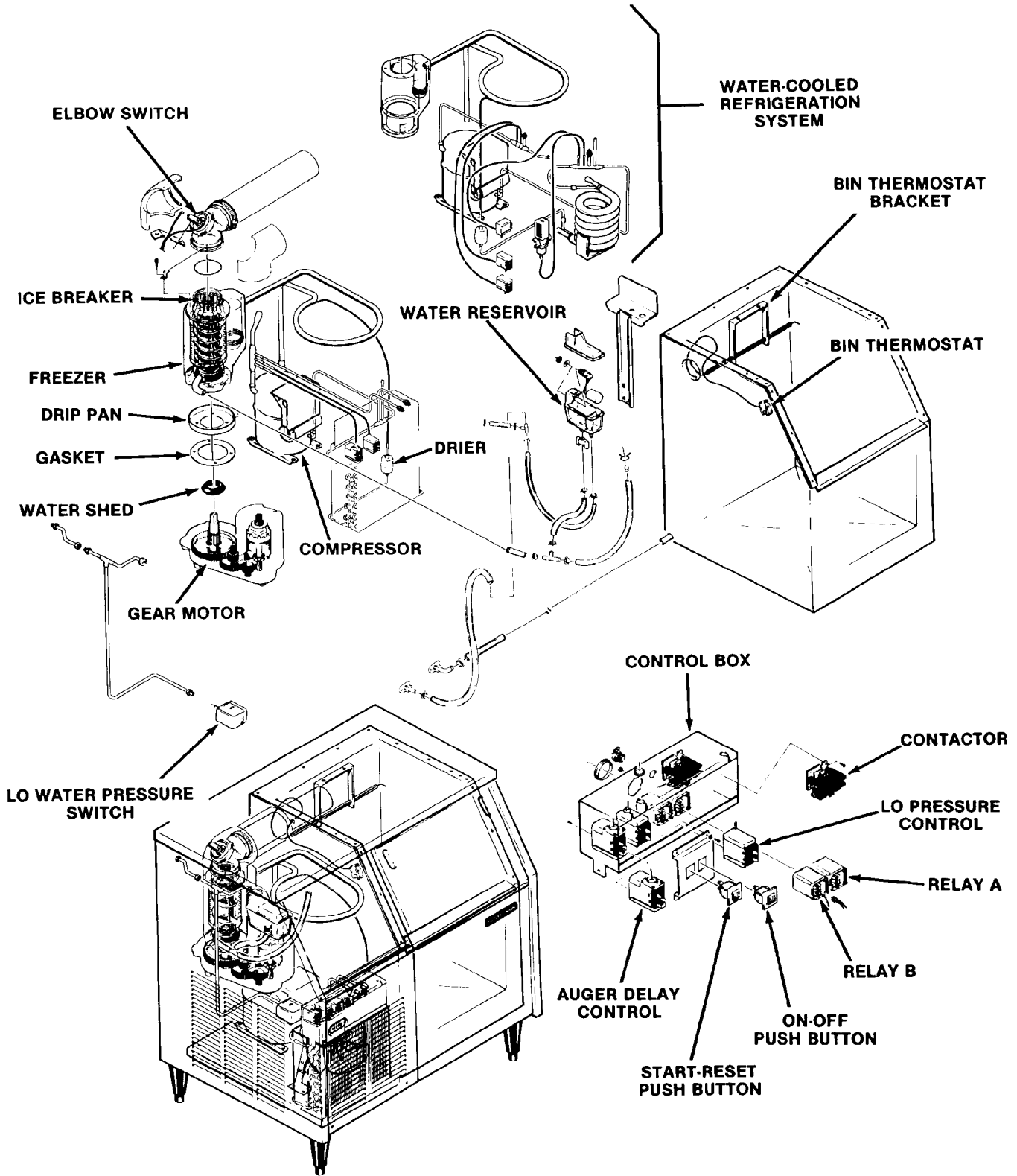

PR760 THE PARTS ILLUSTRATIONS AND PARTS LISTS

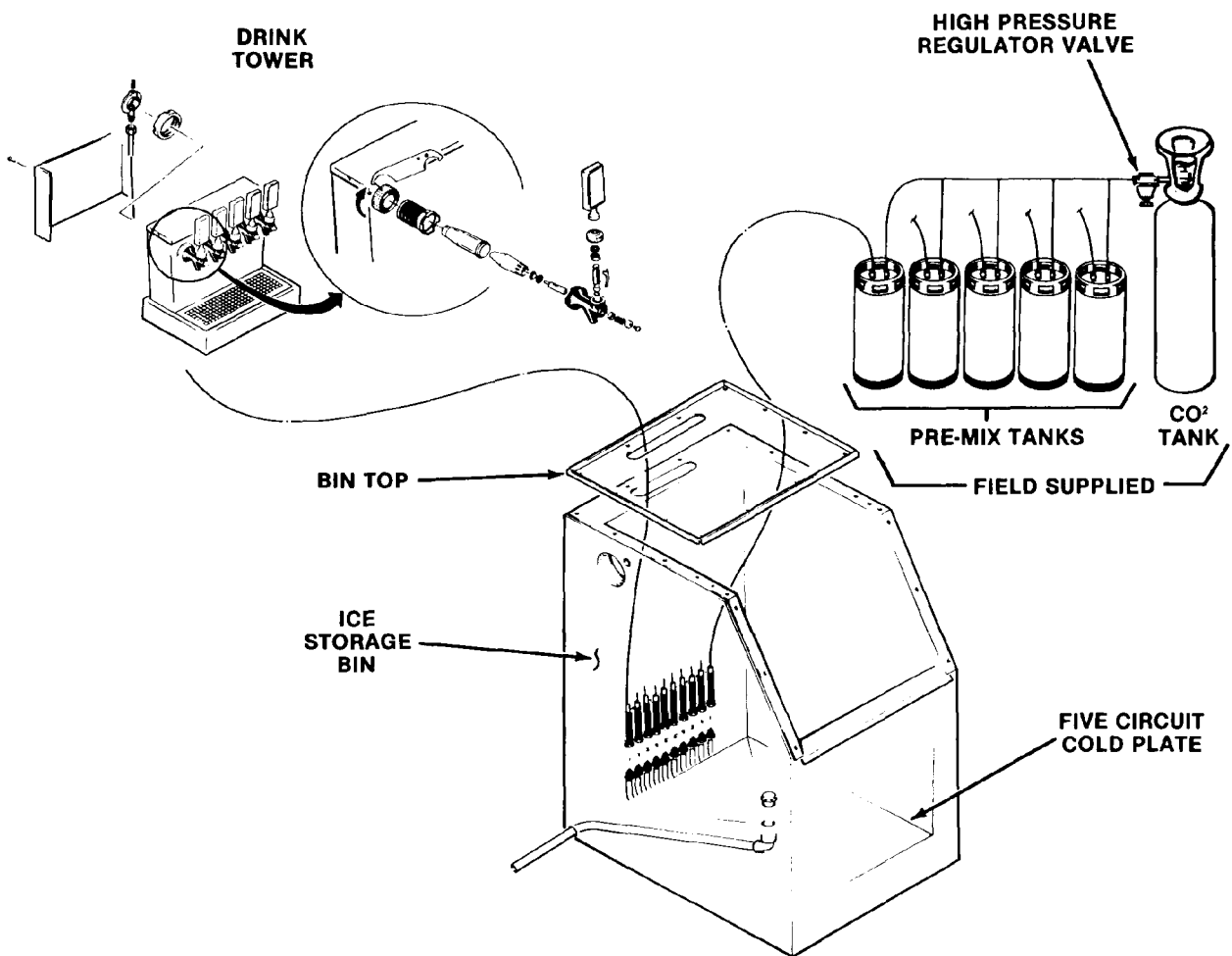

Pre-Mix Drink System

PR760 THE PARTS ILLUSTRATIONS AND PARTS LISTS

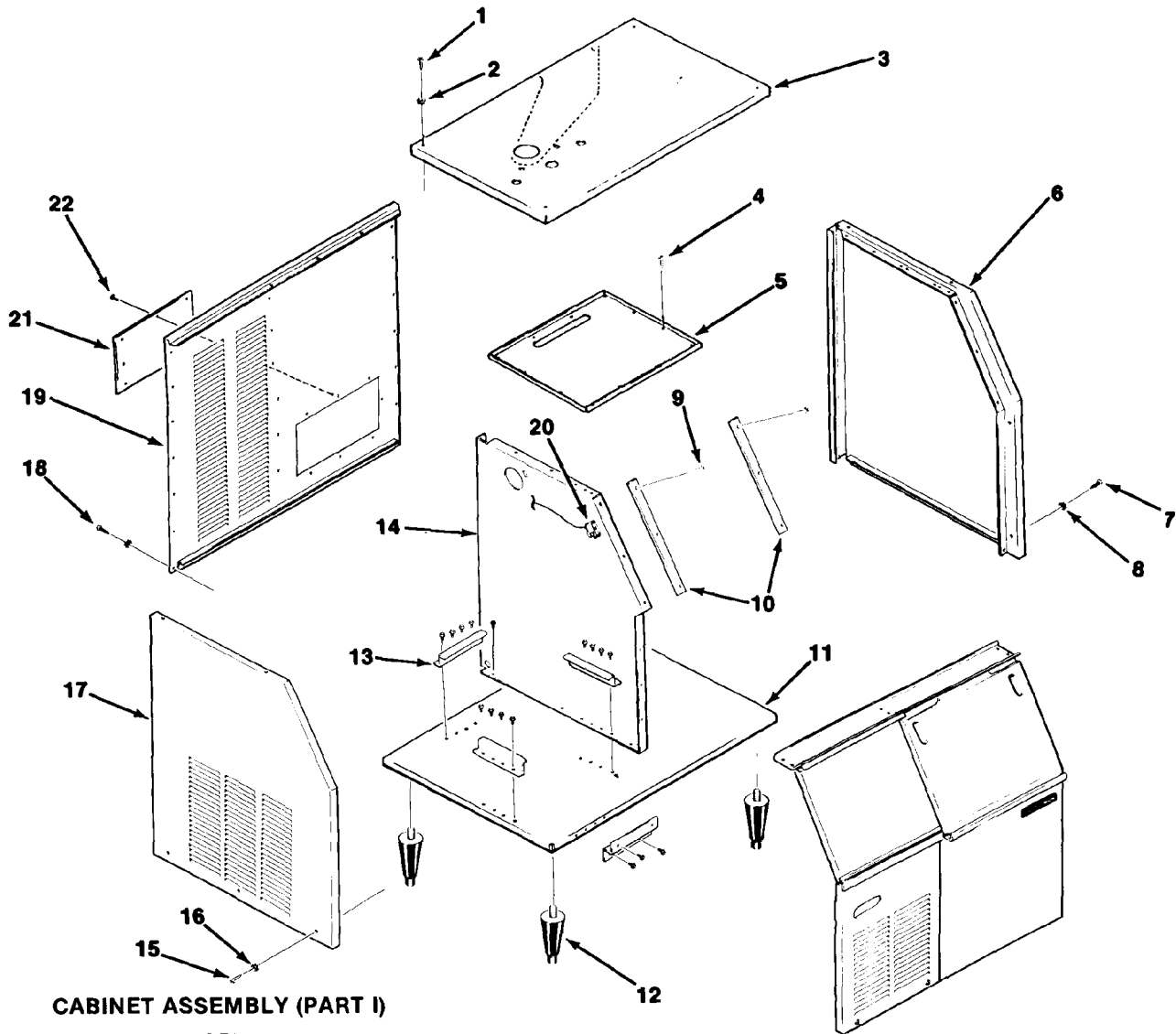

CABINET ASSEMBLY (PART I)

ITEM NUMBER	PART NUMBER	DESCRIPTION
1	03-1419-19	Screw, #8 x 1-3/4
2	03-1417-15	Lockwasher, #8
3	A32212-001	Top Panel, S.S. Only
4	03-1404-09	Screw, #8 x 1/2
5	A30722-001	Cover, Bin
6	A24800-007	Panel, Right Side Enamel
	A24800-002	Panel, Right Side S.S.
7	03-1404-09	Screw, #8 x 1/2
8	03-1417-03	Lockwasher, #8
9	03-1404-10	Screw, #8 x 5/8
10	A30503-001	Support Strip, Right
	A30503-002	Support Strip, Left
11	No Number	Unit Base
12	No Number	Legs, Enamel (KLP2E)
	No Number	Legs, S.S. (KLP2S)
13	No Number	Chassis Stop
14	A27032-002	Insulation Retainer
15	03-1404-09	Screw, #8 x 1/2
16	03-1417-03	Lockwasher, #8
17	A27034-007	Panel, Left Side Enamel
	A27034-002	Panel, Left Side S.S.
18	03-1404-09	Screw, #8 x 1/2
19	A32322-002	Back Panel (C Model)
20	11-0354-00	Bin Thermostat
21	A30507-001	Rear Cover Plate
22	03-1531-03	Screw

PR760 THE PARTS ILLUSTRATIONS AND PARTS LISTS

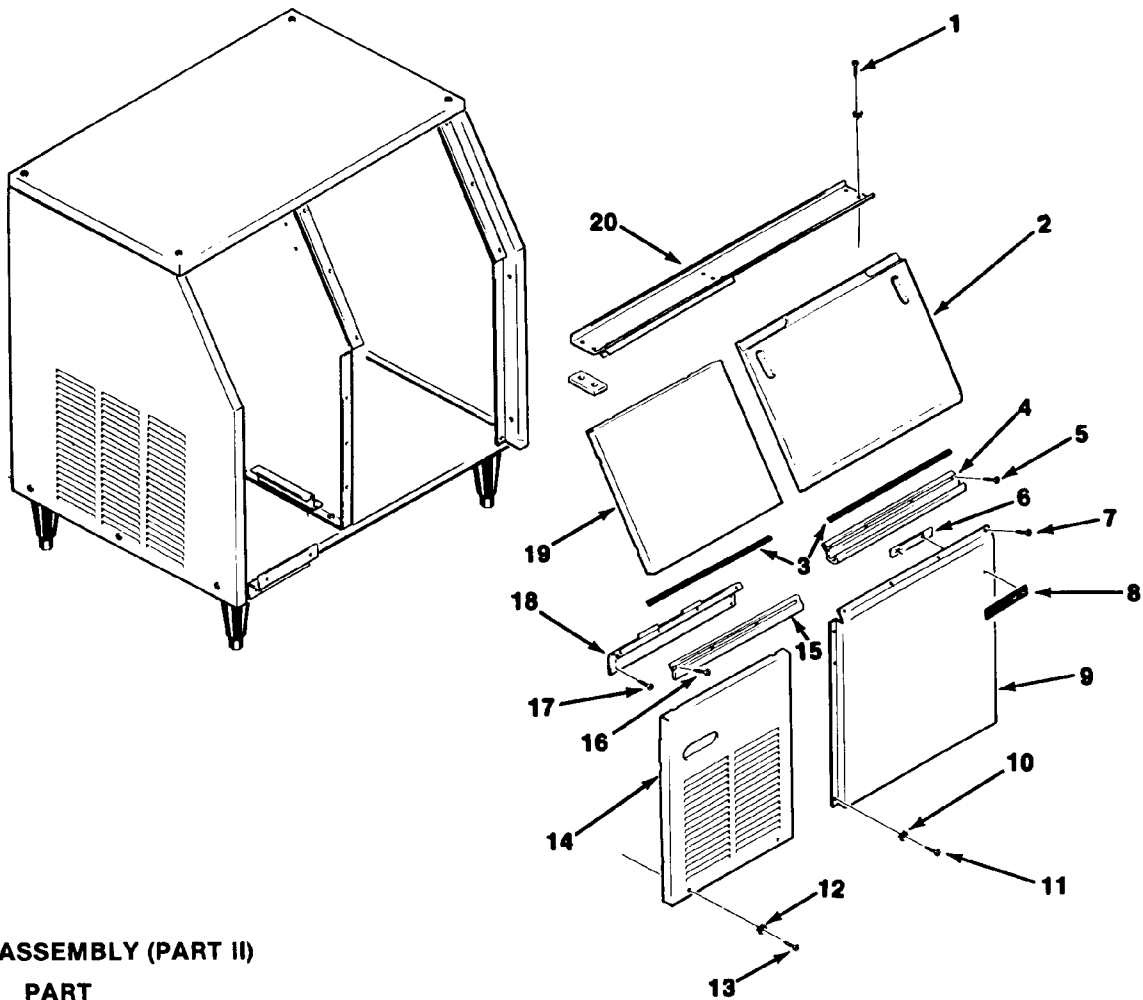

CABINET ASSEMBLY (PART II)

ITEM NUMBER	PART NUMBER	DESCRIPTION
1	03-1404-09	Screw, #8 x 1/2
2	02-2130-01	Ice Access Door, Enamel Units (orange plastic)
	02-2130-02	Ice Access Door, S.S. (grey plastic)
3	15-0324-00	Plastic Insert (36.5")
4	15-0620-01	Moulding Strip
5	03-1419-05	Screw, #8 x 5/8
6	03-0271-00	Speed Clip
7	03-1419-05	Screw, #8 x 1-1/2
8	15-0711-01	Scotsman Emblem
9	A24794-007	Panel, Right Front Enamel
	A24794-002	Panel, Right Front S.S.
10	03-1417-03	Lockwasher, #8
		11 03-1404-09 Screw, #8 x 1/2
		12 03-1417-15 Lockwasher, #8
		13 03-1419-16 Screw, #8 x 1/2
		14 A30496-004 Panel, Lower Left Front, Enamel
		A30496-002 Panel, Lower Left Front, S.S.
		15 15-0706-01 Moulding Strip
		16 03-1419-17 Screw, #8 x 5/8
		17 03-1404-05 Screw, #8 x 1/2
		18 A30502-001 Bracket, Left Front
		19 A30497-005 Panel, Upper Left Front, Enamel
		A30497-002 Panel, Upper Left Front, S.S.
		20 A30539-001 Door Track Assembly

PR760 THE PARTS ILLUSTRATIONS AND PARTS LISTS

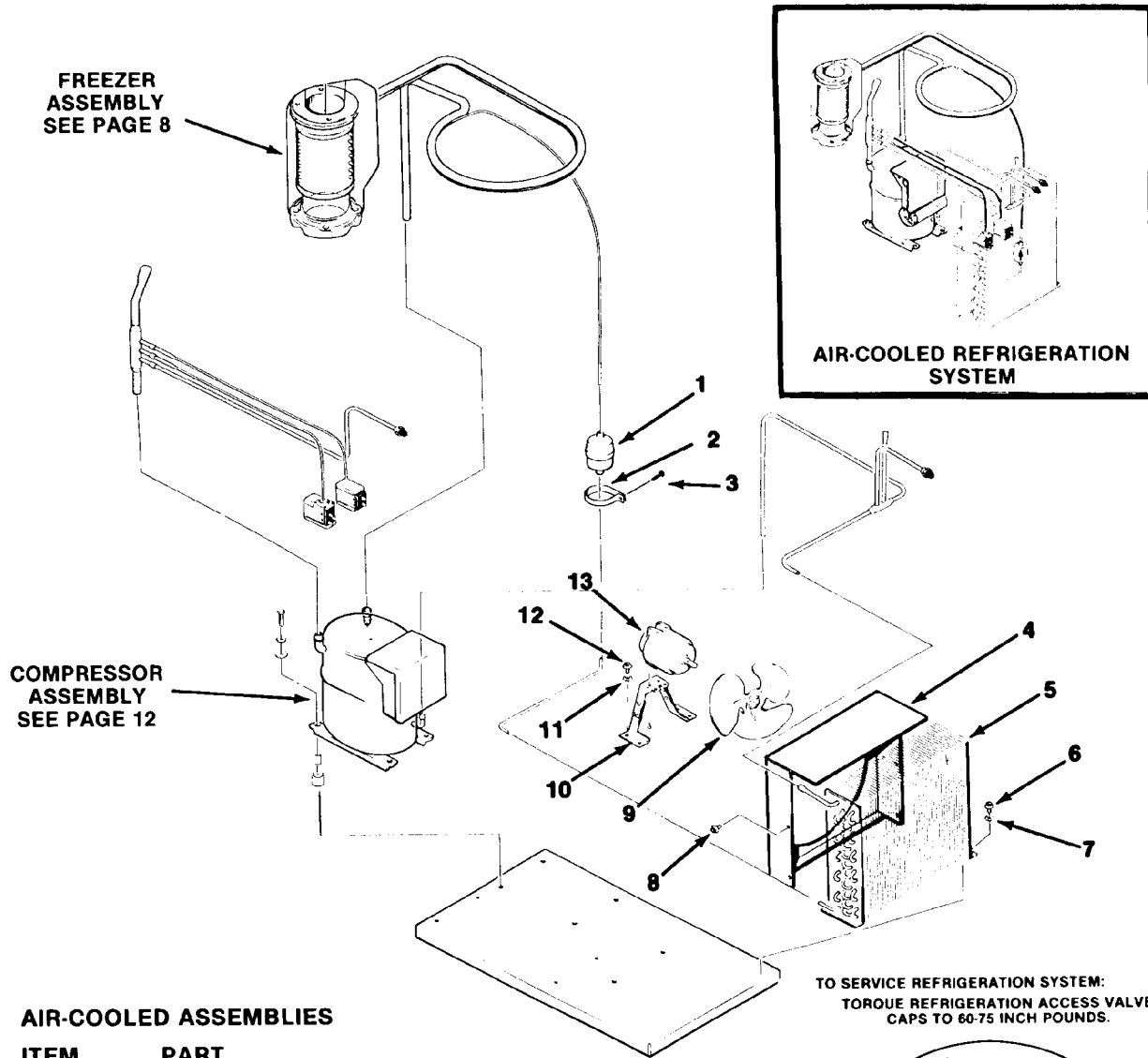

AIR-COOLED ASSEMBLIES

ITEM NUMBER	PART NUMBER	DESCRIPTION
1	02-0544-01	Drier
2	A09388-001	Drier Brace
3	03-1531-01	Screw, #8 x 7/8
4	A30003-001	Shroud
5	18-0396-01	Condenser
6	03-0571-00	Screw, 1/4 - 20 x 1/2
7	03-1417-09	Lockwasher, 1/4
8	03-1404-03	Screw, #6 x 1/4
9	18-0625-00	Fan Blade
10	A25548-001	Fan Mounting Bracket
11	03-1417-09	Lockwasher, 1/4
12	03-0571-00	Screw, 1/4 - 20 x 1/2
13	18-0559-01	Fan Motor 115/60/1

TO SERVICE REFRIGERATION SYSTEM:
TORQUE REFRIGERATION ACCESS VALVE
CAPS TO 60-75 INCH POUNDS.

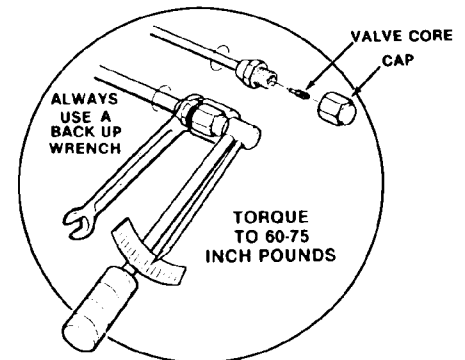

ALWAYS USE A BACK-UP
WRENCH TO AVOID DAMAGE
TO THE REFRIGERANT TUBING.

PR760 THE PARTS ILLUSTRATIONS AND PARTS LISTS

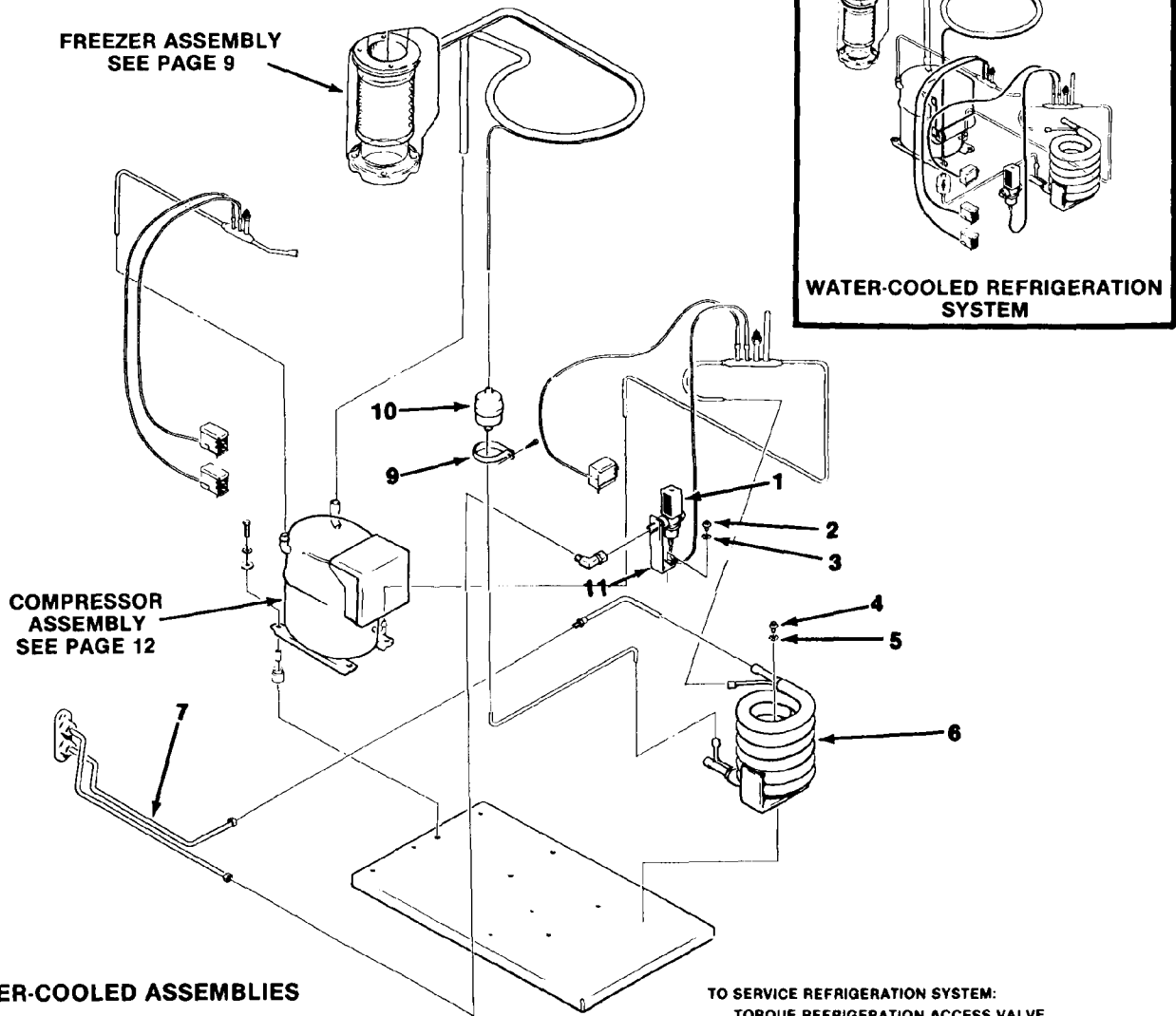

WATER-COOLED REFRIGERATION SYSTEM

WATER-COOLED ASSEMBLIES

ITEM NUMBER	PART NUMBER	DESCRIPTION
1	11-0198-02	Water Regulator Assembly
2	03-0571-00	Screw, 1/4 - 20 x 1/2
3	03-1417-09	Lockwasher, 1/4
4	03-0571-00	Screw, 1/4 - 20 x 1/2
5	03-1417-09	Lockwasher, 1/4
6	18-3305-02	Condenser
7	A32092-001	Drain Assembly, Water-Cooled
8	03-1531-01	Screw, #8 x 7/8
9	A09388-001	Brace
10	02-0544-01	Drier
11	A15924-000	Bracket

TO SERVICE REFRIGERATION SYSTEM:
TORQUE REFRIGERATION ACCESS VALVE
CAPS TO 60-75 INCH POUNDS.

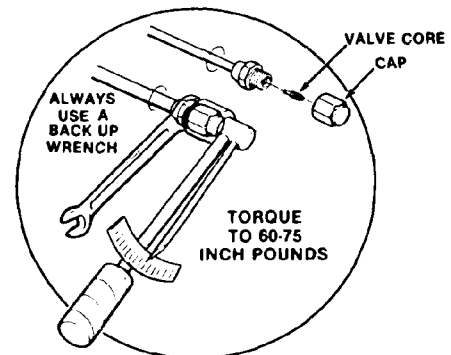

ALWAYS USE A BACK UP
WRENCH TO AVOID DAMAGE
TO THE REFRIGERANT TUBING.

PR760 THE PARTS ILLUSTRATIONS AND PARTS LISTS

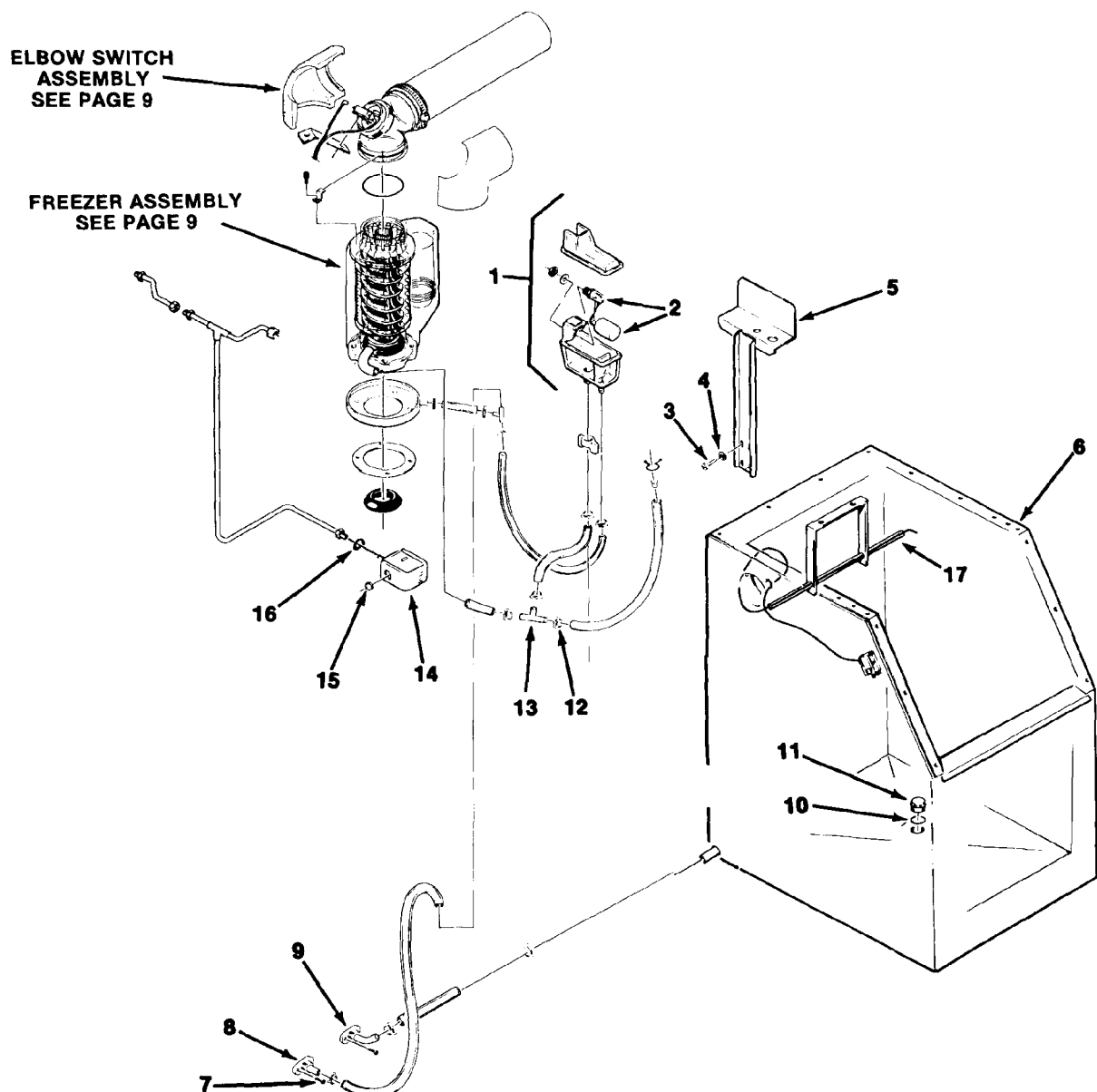

WATER AND DRAINAGE SYSTEM

ITEM NUMBER	PART NUMBER	DESCRIPTION			
1	02-2217-01	Reservoir	9	A32088-001	Drain Assembly
2	02-2217-02	Valve and Float	10	13-0617-11	O-ring
3	03-0571-00	Screw, 1/4 - 20 x 1/2	11	02-1741-00	Drain Top
4	03-1417-09	Lockwasher, 1/4	12	02-0534-00	Hose Clamp
5	A30538-001	Reservoir Bracket	13	16-0670-02	Tee
6	A30464-002	Storage Bin	14	11-0296-00	Lo Water Pressure Control
7	03-1405-03	Screw, 1/4 - 20 x 1/2	15	12-1213-10	Snap Bushing
8	A32091-001	Drain Assembly (Water-Cooled only)	16	No Number	Rubber Washer
			17	A30720-001	Bin Thermostat Bracket

PR760 THE PARTS ILLUSTRATIONS AND PARTS LISTS

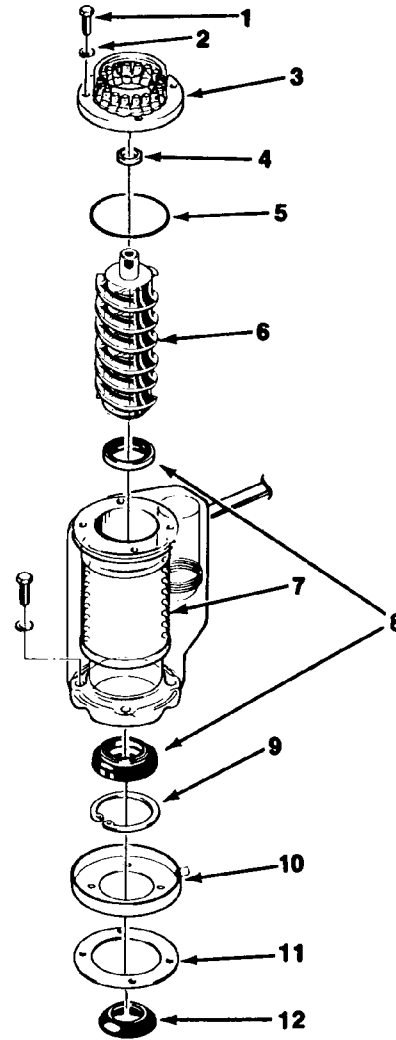
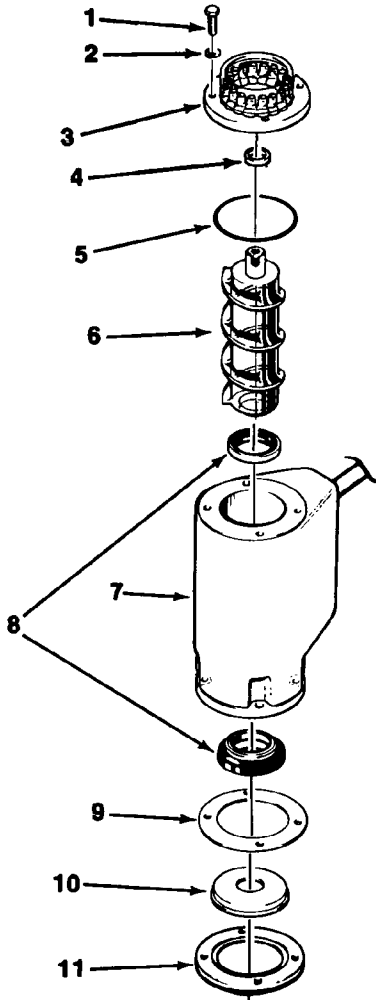

FREEZER ASSEMBLY (A & B MODELS ONLY)

ITEM NUMBER	PART NUMBER	DESCRIPTION
1	03-1405-42	Screw, No. 5/16 - 18 x 7/8 Hex Cap
2	03-1417-13	Lockwasher, No. 5/16 Helical Spring
3	A32571-020	Ice Breaker (Includes Bearing & Seal)
4	02-2853-01	Seal
5	13-0617-46	O-Ring
6	A31839-001	Auger
7	A32098-020	Freezer Assembly
8	02-0929-01	Seal, Water
9	13-0704-00	Gasket
10	A29463-001	Adapter Freezer
11	02-2577-01	Adapter Large

FREEZER ASSEMBLY (C MODEL ONLY)

ITEM NUMBER	PART NUMBER	DESCRIPTION
1	03-1405-42	Screw
2	03-1417-13	Lockwasher
3	A32571-020	Ice Breaker (Includes Bearing & Seal)
4	02-2853-01	Seal
5	13-0617-46	O-Ring
6	A31839-001	Auger
7	A32098-020	Freezer Assembly (Includes 10 & 11)
8	02-0929-01	Water Seal
9	03-1558-05	Snap Ring
10	A32050-001	Drip Pan
11	13-0704-00	Gasket
12	13-0700-02	Water Shed

A31340-001

PR760 THE PARTS ILLUSTRATIONS AND PARTS LISTS

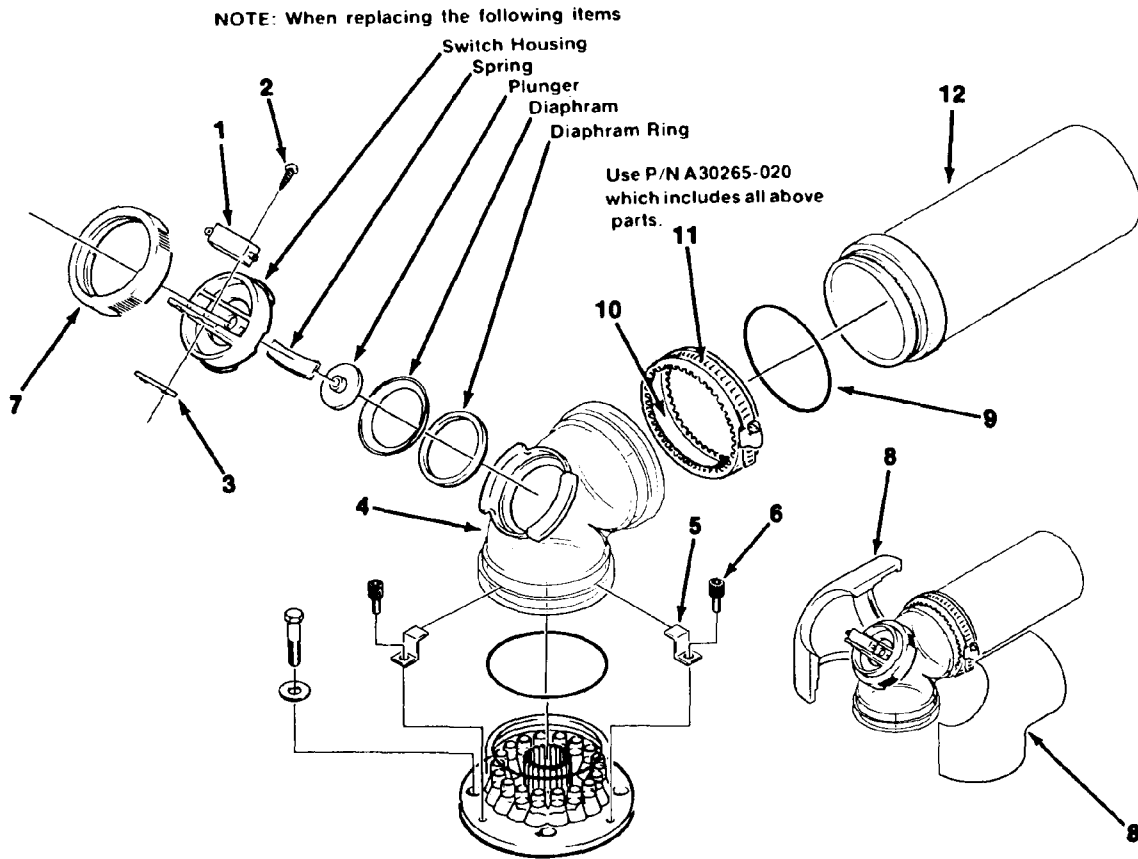

ELBOW AND SWITCH ASSEMBLY

ITEM NUMBER	PART NUMBER	DESCRIPTION
1	12-2202-01	Switch
2	03-1403-08	Screw, No. 6-32 x 7/8
3	03-0886-00	Speednut
4	02-2764-01	Elbow Assembly
5	02-2604-01	Bracket, Spout Retaining
6	03-1544-04	Screw, No. 10-24 x 3/8 S.S. Soc Hd Cap
7	02-2637-01	Retaining Ring
8	A31390-001	Insulation (Includes left & right sides)
9	13-0619-49	O-Ring
10	A30089-001	U-Channel
11	02-0179-03	Clamp
12	A30087-004	Ice Tube

PR760 THE PARTS ILLUSTRATIONS AND PARTS LISTS

DRIVE MOTOR ASSEMBLY

ITEM NUMBER	PART NUMBER	DESCRIPTION
1	02-1606-00	Oil Seal
2	19-0709-02	Water Shed C Model Only <i>A31340-001</i>
3	02-2853-01	Oil Seal Top - Faces Up
4	03-1251-01	Screw*
5	A31230-001	Gear Case Cover Assembly*
6	02-1681-00	Thrust Race
7	03-1363-00	Retaining Ring
8	02-2541-01	Shaft, Output
9	03-1630-01	Key
10	02-2745-01	Gear, Output
11	02-1604-00	Third Pinion Assembly, Second Gear
12	02-1679-00	Thrust Race
13	A32368-020	Bearing (Includes Items 12, 13, & 14)
14	02-1679-00	Thrust Race
15	A26103-001	"O" Ring
16	A31230-001	Gear Case Assembly Bottom*
17	03-1408-24	Washer
18	02-1603-00	Second Pinion Assembly, First Gear
19	03-1408-24	Washer
20	12-1741-29	Bearing Shaft GE
	12-1741-20	Bearing Shaft Emerson
	12-2314-20	GE P.S.C.
21	A32425-001	Drive Motor
22	12-1741-28	Switch, Start (General Electric) #1
	12-1741-32	Start Switch (General Electric) #2
	12-2314-21	Centrifugal Switch P.S.C.
	12-1741-22	Switch, Start (Emerson)
23	A25835-001	Gearcase Oil (1) Pint
24	A32404-021	Gearmotor Assembly Complete
25	12-2314-22	Capacitor (G.E. PSC Only)

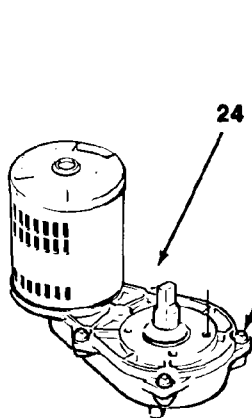
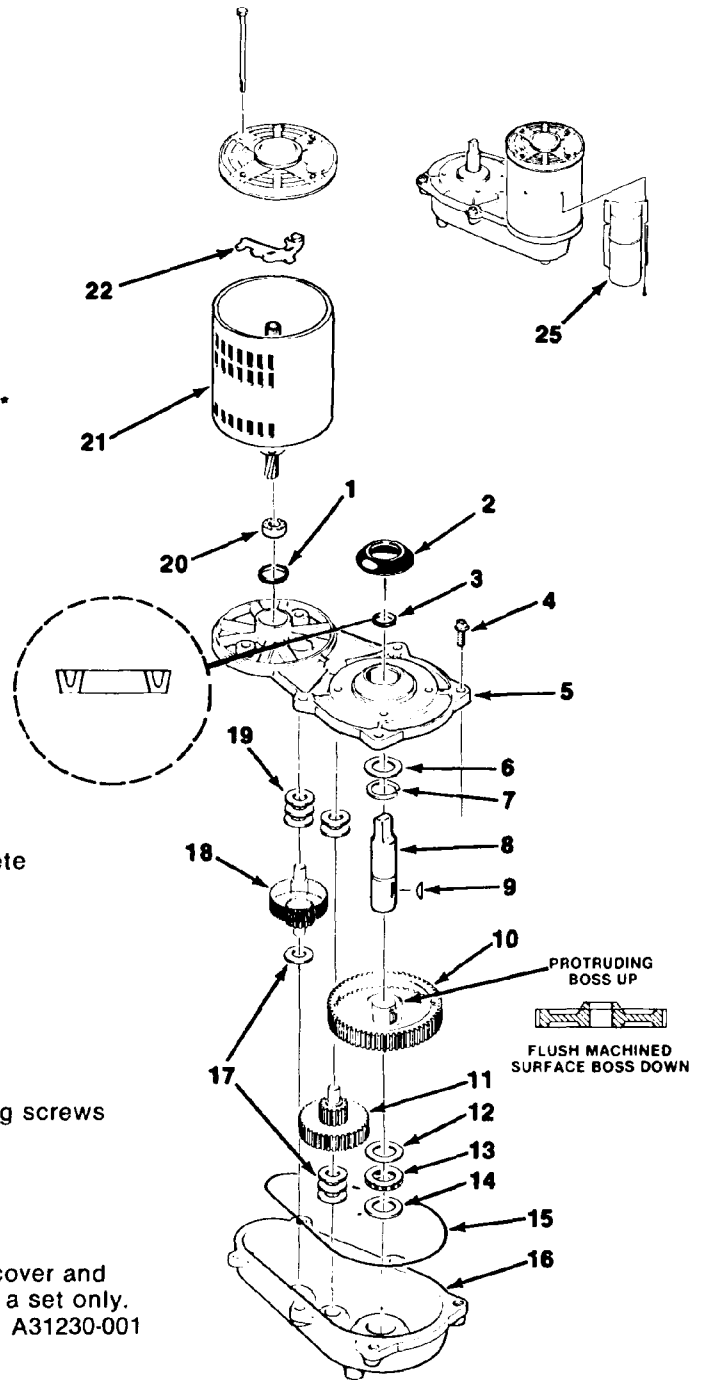

*NOTE: Torque cover mounting screws
250-300 inch pounds.

*NOTE: Gearcase cover and
bottom are sold as a set only.
Order Part Number A31230-001

PR760 THE PARTS ILLUSTRATIONS AND PARTS LISTS

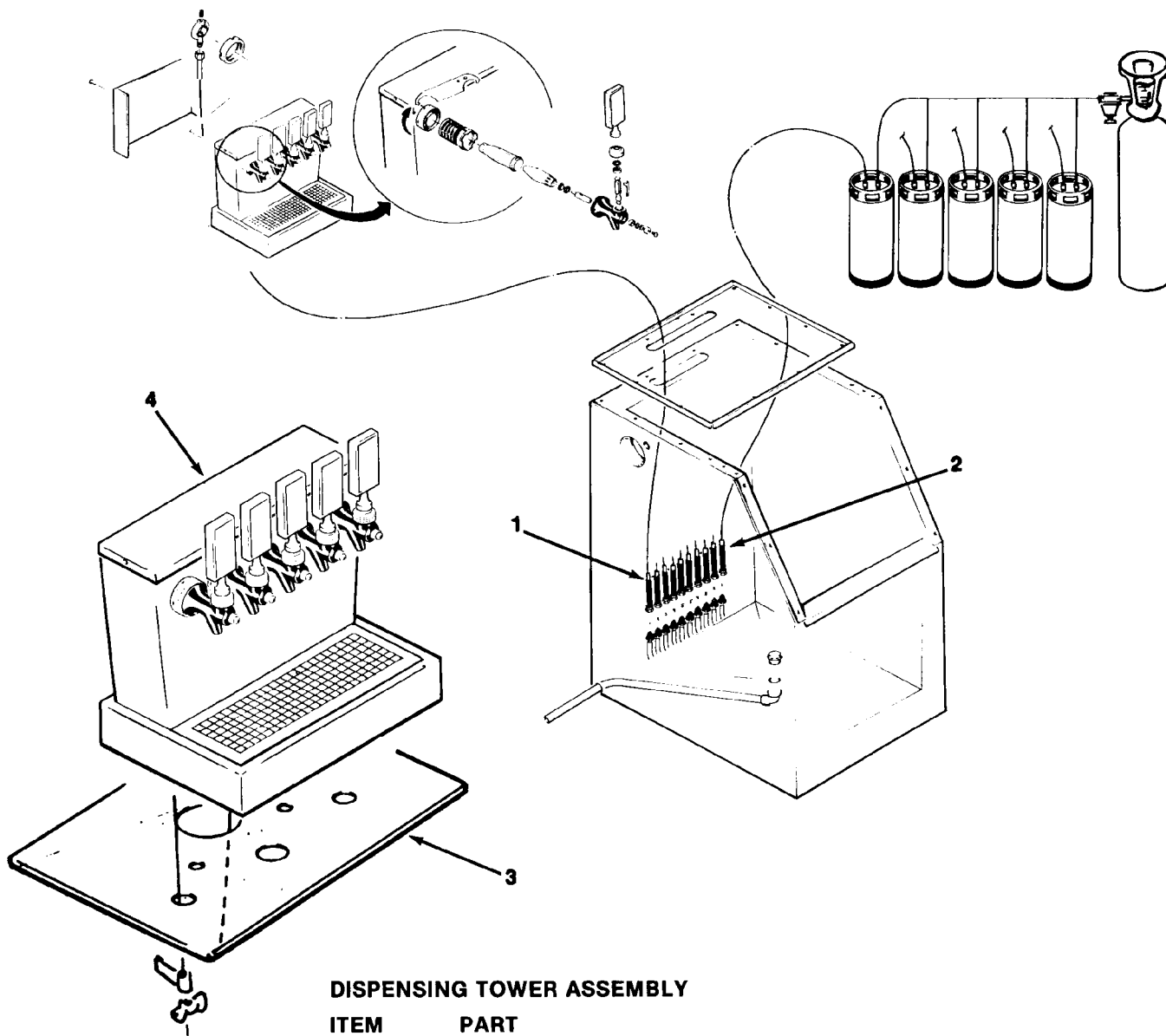

DISPENSING TOWER ASSEMBLY

ITEM NUMBER	PART NUMBER	DESCRIPTION
1	A27737-007	Tube Assembly (cold plate to tower)
2	A30541-001	Tube Assembly (cold plate to pre-mix tank)
3	A30501-001	Mounting Plate
4	No Number	Dispensing Tower

PR760 THE PARTS ILLUSTRATIONS AND PARTS LISTS

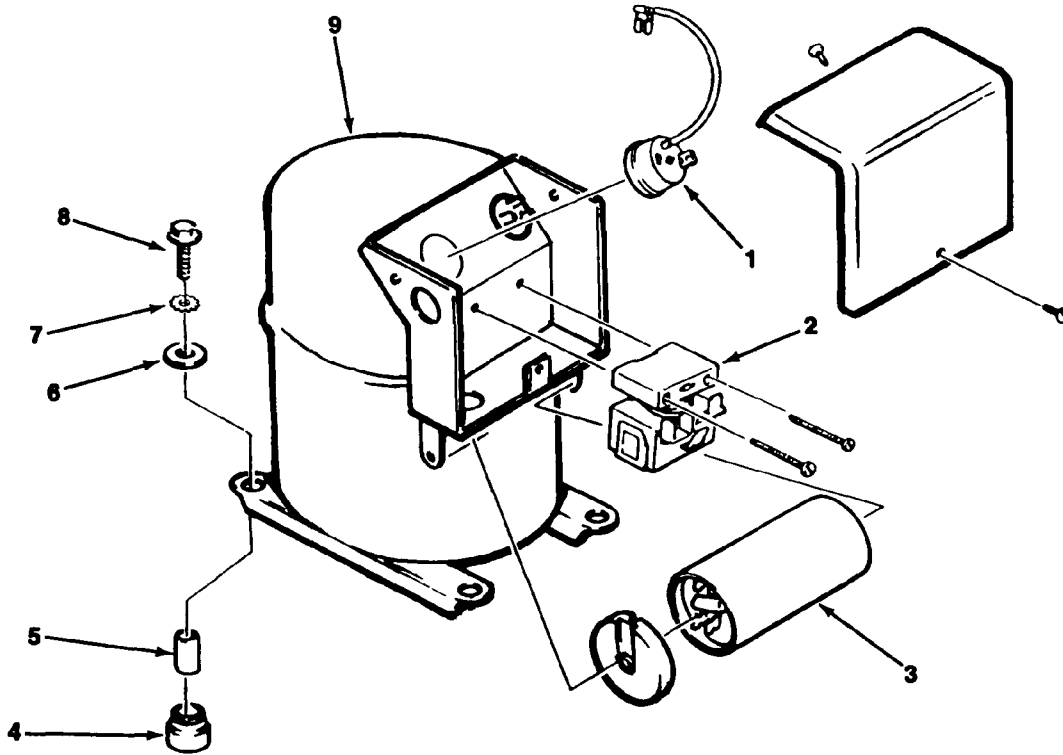

COMPRESSOR ASSEMBLY

ITEM NUMBER	PART NUMBER	DESCRIPTION
1	18-2400-25	Overload (115/60/1)
2	18-2410-00	Relay (115/60/1)
3	18-2420-00	Capacitor with cap, (115/60/1)
4	18-2200-28	Grommet
5	18-2200-27	Sleeve
6	03-1408-29	Washer
7	03-1417-12	Lockwasher
8	03-1405-40	Screw
9	18-3900-01	Compressor Assembly, (115/60/1)

PR760 THE PARTS ILLUSTRATIONS AND PARTS LISTS

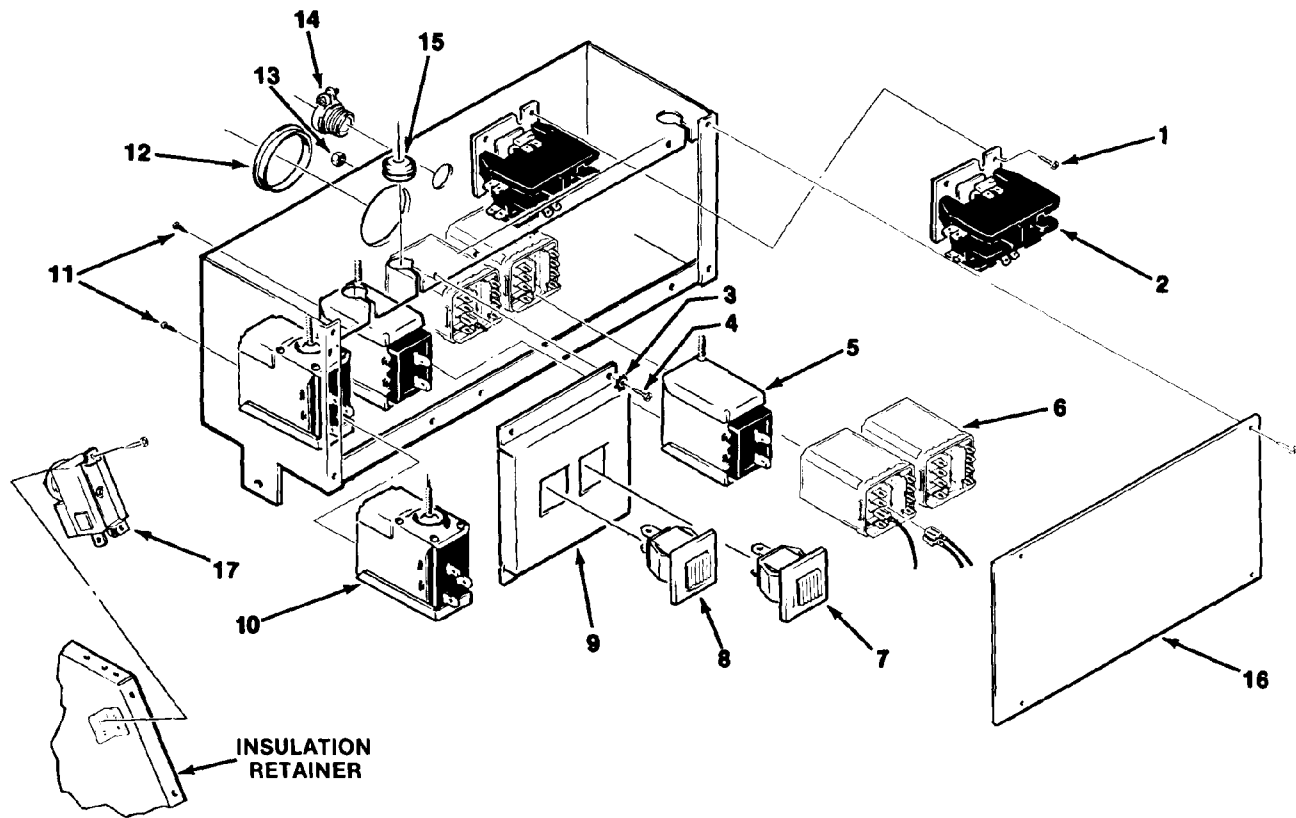

CONTROL BOX ASSEMBLY - AIR-COOLED

ITEM NUMBER	PART NUMBER	DESCRIPTION
1	03-1531-01	Screw, #8 x 3/8
2	12-2048-01	Contactora, (115/60/1)
3	03-1417-03	Lockwasher
4	03-1531-01	Screw, #8 x 3/8
5	11-0402-01	Lo Pressure Control (Auger Delay)
6	12-2090-01	Relay, (115/60/1)
7	12-2200-01	ON-OFF Switch, (115/60/1)
8	12-2199-01	Start-Reset Switch, (115/60/1)
9	A30543-001	Switch Housing
10	11-0420-01	Low Pressure Control
11	03-1403-02	Screw, #6 x 1/4
12	12-1213-12	Snap Bushing
13	03-1406-01	Nut
14	12-0256-00	Straight Connector
15	13-0557-00	Grommet
16	A31654-001	Control Box Cover
17	11-0354-00	Bin Thermostat (Located on Insulation Retainer)

PR760 THE PARTS ILLUSTRATIONS AND PARTS LISTS

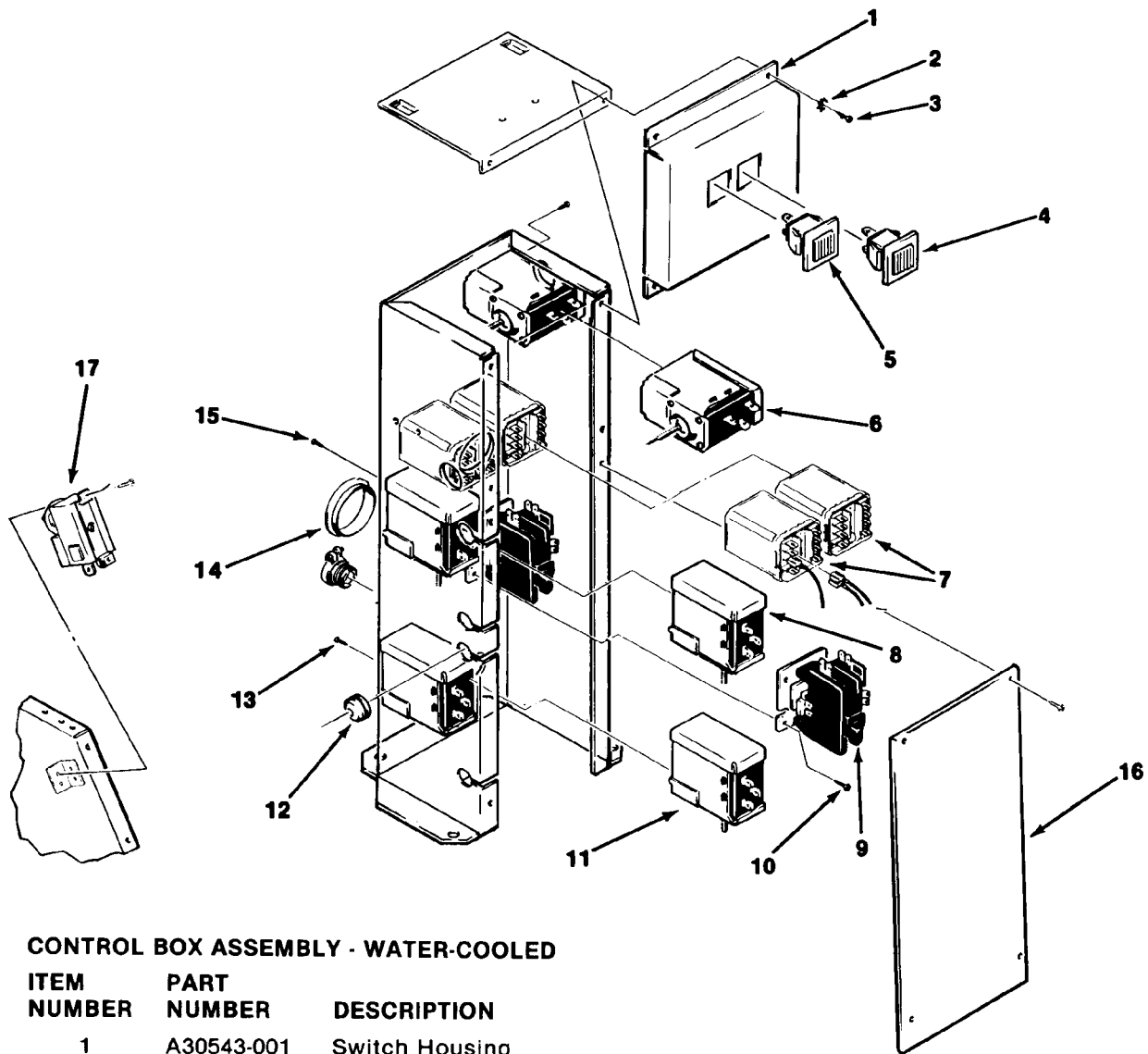

CONTROL BOX ASSEMBLY - WATER-COOLED

ITEM NUMBER	PART NUMBER	DESCRIPTION
1	A30543-001	Switch Housing
2	03-1417-03	Lockwasher
3	03-1531-01	Screw, #8 x 3/8
4	12-2200-01	ON-OFF Switch, (115/60/1)
5	12-2199-01	Start-Reset Switch, (115/60/1)
6	11-0388-02	Hi Pressure Control
7	12-2090-01	Relay, (115/60/1)
8	11-0402-01	Auger Delay - Control
9	12-2048-01	Contactor, (115/60/1)
10	03-1531-01	Screw, #8 x 3/8
11	11-0420-01	Low Pressure Control
12	13-0557-00	Grommet
13	03-1403-02	Screw, #6 x 1/4
14	12-1213-10	Snap Bushing
15	03-1413-02	Screw, #6 x 1/4
16	A30542-001	Control Box Cover
17	11-0354-00	Bin Thermostat (Located on Retainer)

PR760 WIRING DIAGRAM

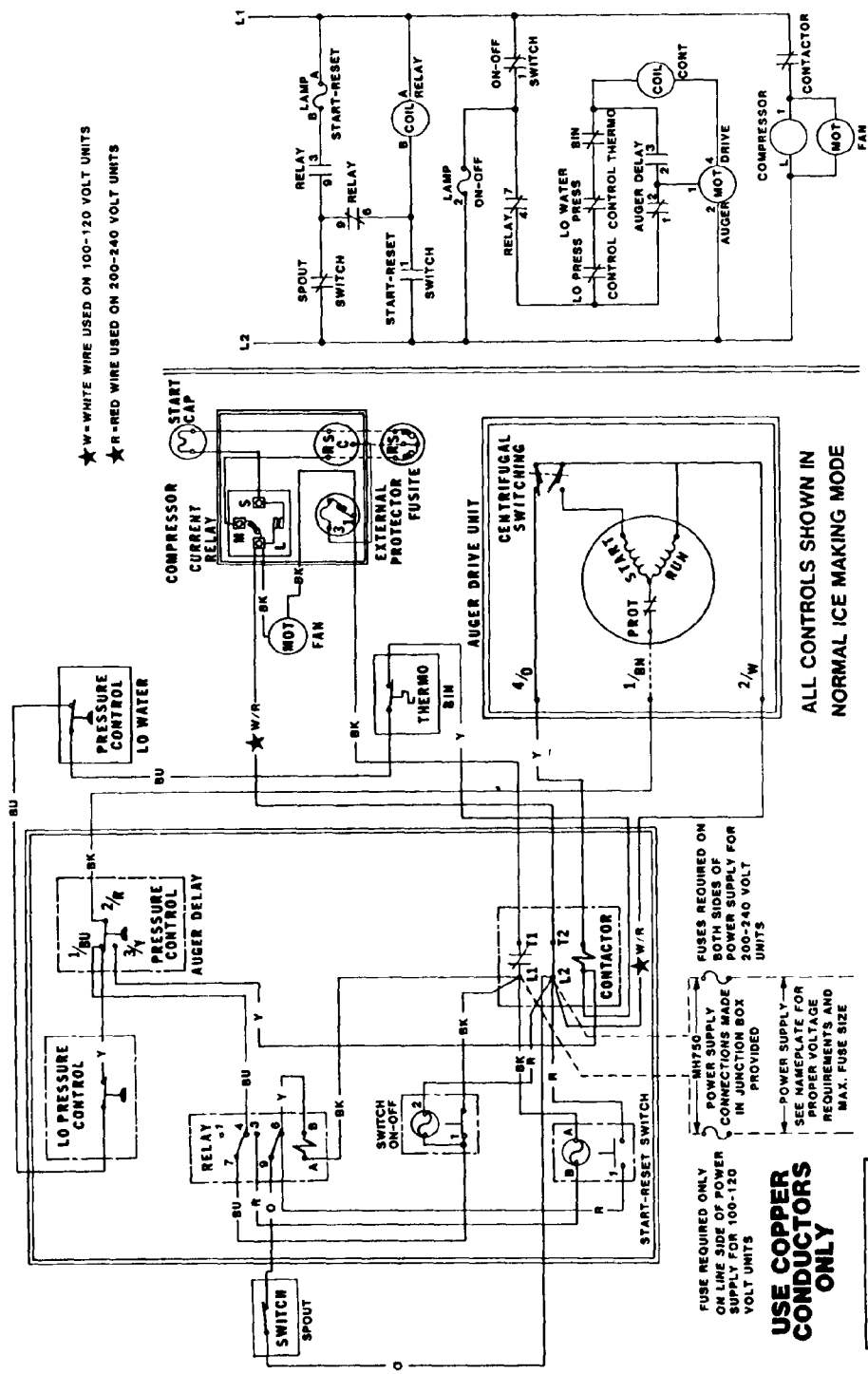

★ W-WHITE WIRE USED ON 100-120 VOLT UNITS
 ★ R-RED WIRE USED ON 200-240 VOLT UNITS

ALL CONTROLS SHOWN IN
 NORMAL ICE MAKING MODE

THIS UNIT MUST BE GROUNDED

FUSE REQUIRED ONLY ON LINE SIDE OF POWER SUPPLY FOR 100-120 VOLT UNITS

FUSES REQUIRED ON BOTH SIDES OF POWER SUPPLY FOR 200-240 VOLT UNITS

SEE MAKEPLATE FOR PROPER VOLTAGE REQUIREMENTS AND MAX. FUSE SIZE

USE COPPER CONDUCTORS ONLY

A30534-001

Wiring Diagram, PR760AE-1A (115/60/1) Air-Cooled

PR760 WIRING DIAGRAM

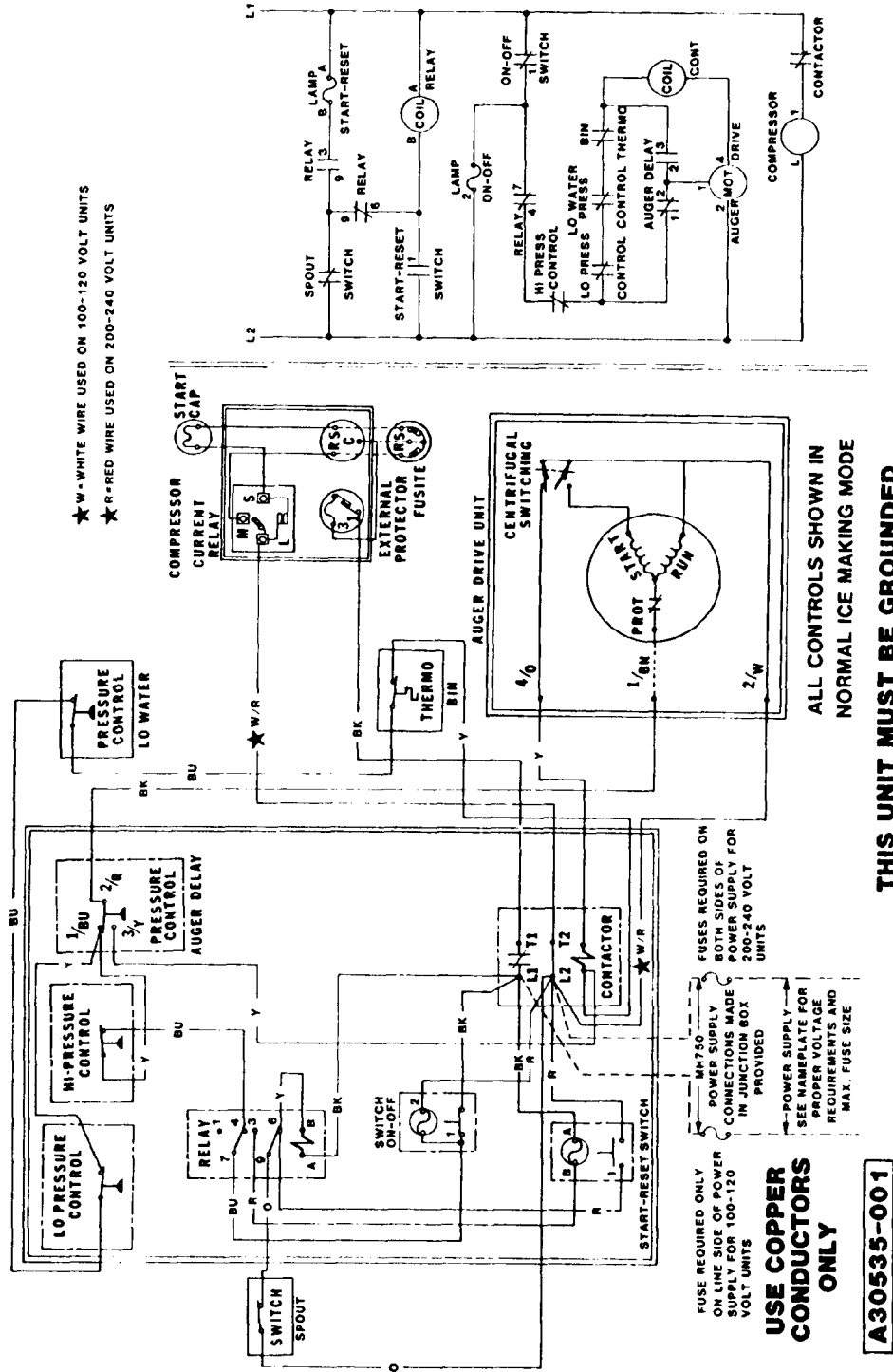

Wiring Diagram, PR760WE-1A (115/60/1) Water-Cooled

PR760 WIRING DIAGRAM

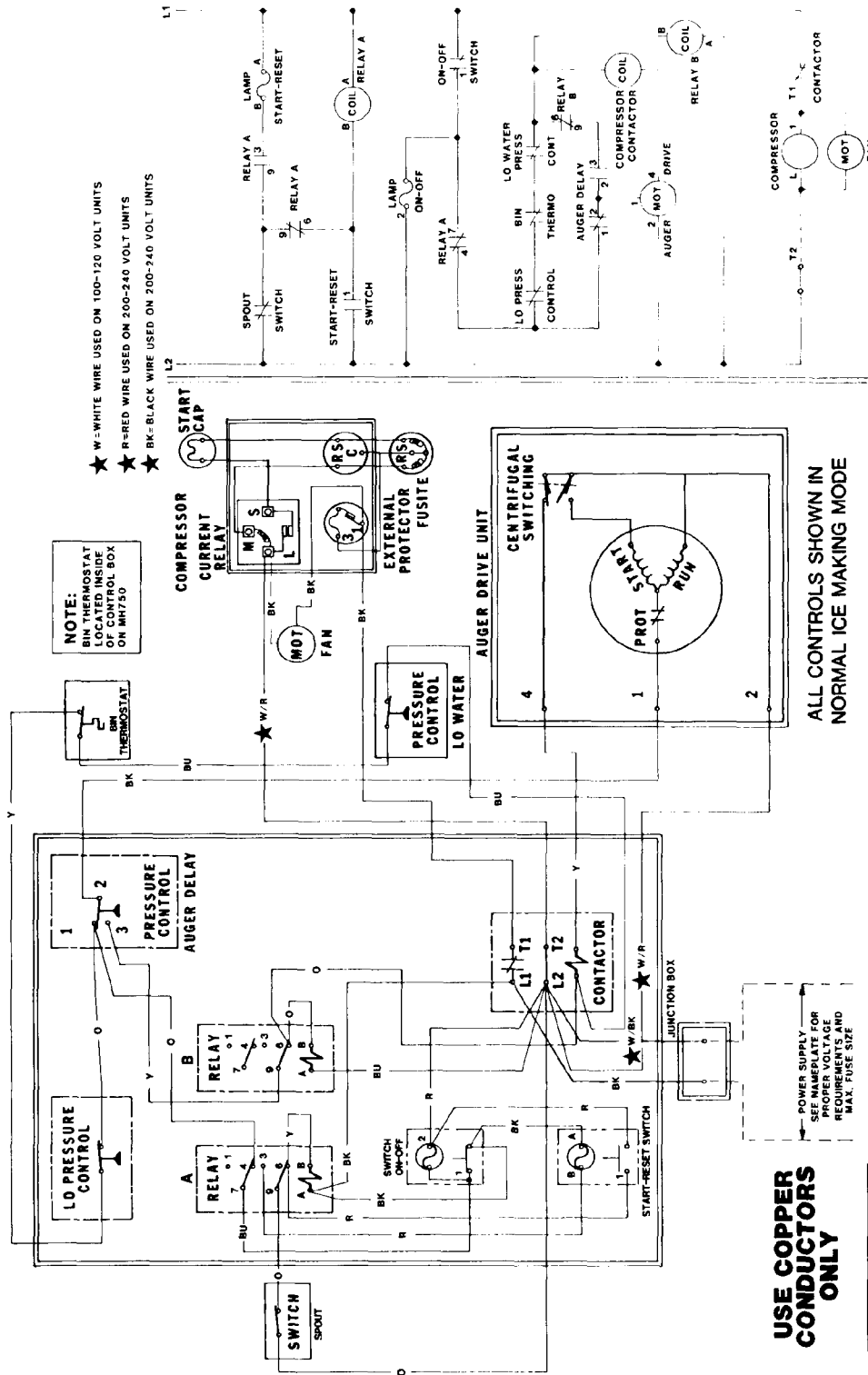

Wiring Diagram, PR760AE-1C (115/60/1) Air-Cooled

PR760 WIRING DIAGRAM

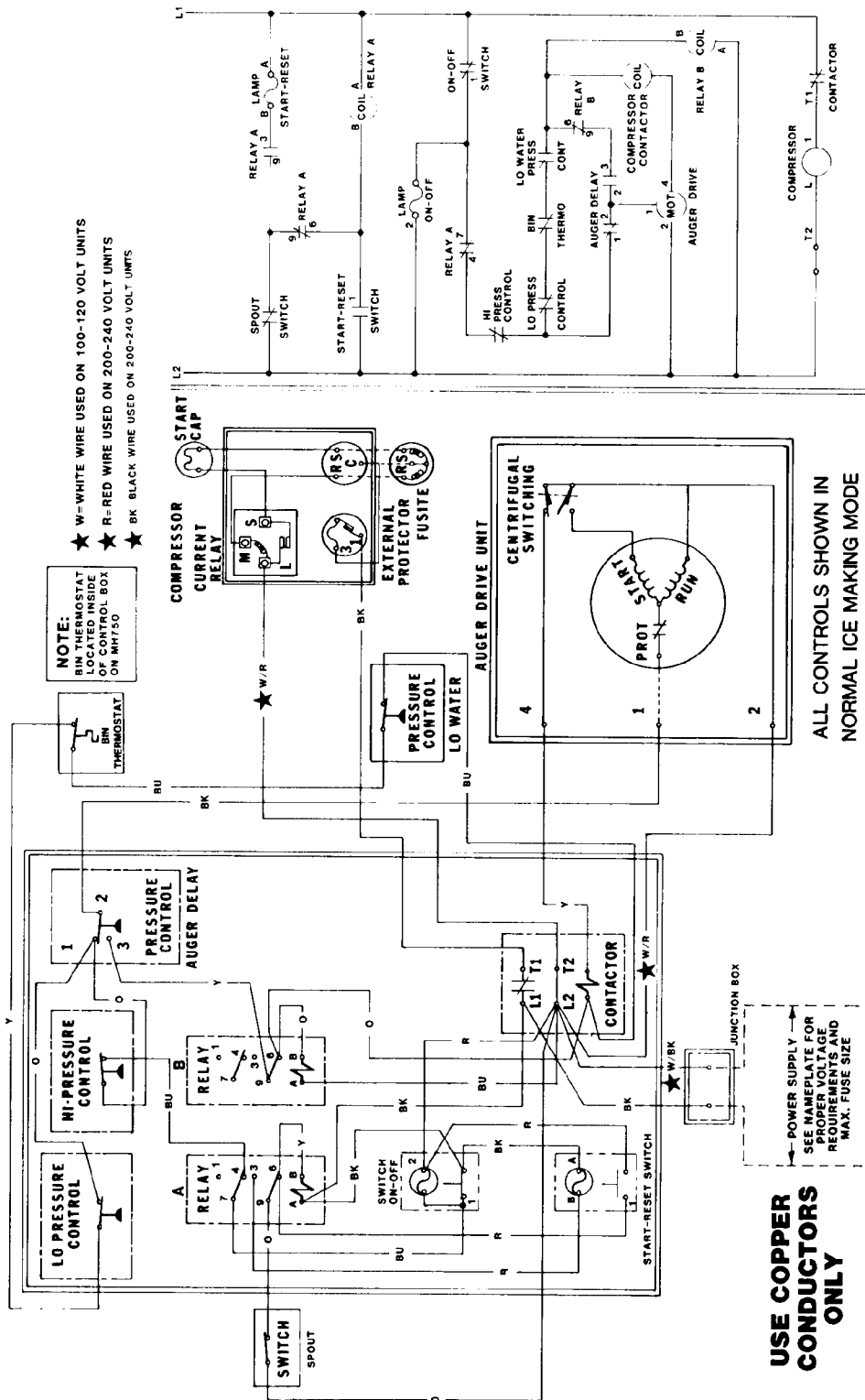

Wiring Diagram, PR760WE-1C (115/60/1) Water-Cooled