

## INTRODUCTION

---

This service manual is intended as a reference for the installer, user, and service agent of this Scotsman Refreshment Stand. It includes the necessary information to install, start up, operate, clean and maintain this unit.

### TABLE OF CONTENTS

Specifications . . . . .	Page 2
Loose Shipped Parts . . . . .	Page 3
For the Installer . . . . .	Page 4
Soda System Schematics . . . . .	Page 6
How it Works . . . . .	Page 8
Initial Start Up . . . . .	Page 9
For the Operator . . . . .	Page 10
Cleaning & Sanitizing . . . . .	Page 13
Sanitizing Syrup System . . . . .	Page 15
Service Diagnosis . . . . .	Page 16
Electrical Sequence . . . . .	Page 18
Repair . . . . .	Page 19

***Parts lists and wiring diagrams are located in the center of this manual, printed on colored paper.***

This manual contains important information, read it before installation or operation.  
Keep it for future reference.

### Safety Symbol:



**Important safety information on a hazard that might cause serious injury.**

# RS100 and RS150

## SPECIFICATIONS

---

The term "Refreshment Stand" means a machine that stores ice in an insulated, sanitary container; upon demand it dispenses that ice into a cup or glass; it cools beverages using ice falling from the hopper onto a cold plate below the hopper; and it dispenses beverages via post-mix or pre mix valves. One of the valves (2nd from left) is not carbonated; it may be changed to carbonated if desired. Power to operate the valves may be shut off by a key switch.\*

An important feature of this dispenser is that the ice on the cold plate is not dispensed.

\* Premix is not electrically powered.

The RS requires additional equipment to be functional:

An ice machine or source of sanitary ice; a carbonator for post mix (and potable water); a syrup delivery system, either pressurized syrup cans or bag-in-a-box; and CO<sub>2</sub>. The dispenser must also be connected to a drain.

NOTE: This Refreshment Stand is designed to dispense cubed or Nugget ice only. **Flaked ice will not work.**

Base Model	Dimensions	Storage Capacity	Basic Electrical	Amperage	Power Cord
RS100B	22"w x 30"d x 34"h	125 lbs.	115/60/1	2 amps	4' with plug
RS150B	30"w x 30"d x 34"h	165 lbs.	115/60/1	2 amps	4' with plug

Rotor motor is 1/10 H.P.

Options: Lighted upper front panel. 4" leg kit. Fast flow carbonator (100 G.P.H.). Push button actuation (factory installed). Standard or fast flow Booth, Cornelius, McCann or Dole valves. Also available in premix with Booth Capre valves only.

Scotsman Drink Systems are designed and manufactured with the highest regard for safety and performance. They meet or exceed the standards of U.L., N.S.F., and C.S.A.

Scotsman assumes no liability or responsibility of any kind for products manufactured by Scotsman that have been altered in any way, including the use of any parts and/or other components not specifically approved by Scotsman

Scotsman reserves the right to make design changes and/or improvements at any time. Specifications and designs are subject to change without notice.

# RS100 and RS150

## FOR THE INSTALLER: Installation Of Loose Shipped Parts

### Drip Tray/Grill

1. Remove splash panel from unit.
2. Place a worm drive clamp over the drain tube as shown.
3. Hold drip tray at an angle of approximately  $30^{\circ}$ . Hold flexible drain tube between two fingers with other hand and push drip tray drain fitting into the tube.

**SIDE VIEW OF DRIP TRAY INSTALLATION**

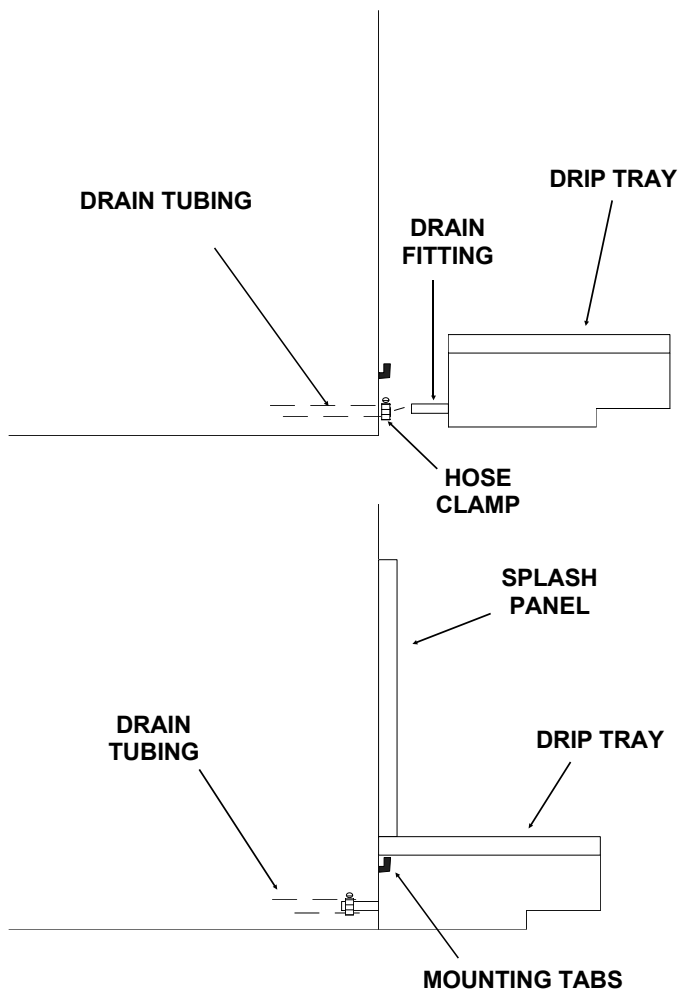

4. Check that the drain tubing is in place, and tighten the hose clamp.
5. Hang the drip tray onto the metal tabs on the base of the unit.
6. Replace the splash panel.

### Ice lever/Ice Chute/Fluorescent Tube\*

1. Pull out and remove upper front panel.
2. Slide out ice chute mounting panel.

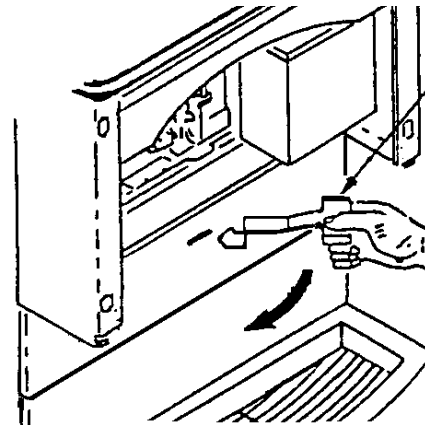

:R

3. Insert the ice lever in to the valve panel through the slot as shown.
4. Swing the ice lever through from right to left and let it hang freely.
5. Twist the fluorescent tube into the sockets.
6. Replace ice chute mounting panel.
7. Insert clear ice chute into the panel and twist clockwise  $1/3$  turn.

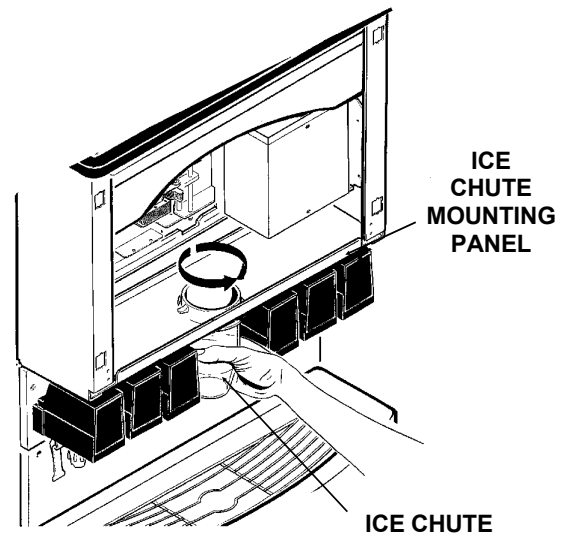

8. Replace the upper front panel.

\* Optional depending on unit configuration.

# RS100 and RS150 FOR THE INSTALLER

1. Locate the dispenser on the counter. Allow vertical clearance above unit for the removal of the cover, and for pouring ice into the hopper.

The syrup and carbonated water connections need to be made at the cold plate's stub lines. The cold plate is located under the hopper; stub lines are at the back of the cabinet.

Note: Beginning with RS100, sn 594922-06Y and RS150, sn 594966-067, cold plate connections are at the front of the unit, behind the splash panel.

Tubing routing to the cold plate is from either the back of the unit, or through any of the openings in the base.

A plumbing circuit schematic diagram is on the back of the cabinet, refer to it for cold plate connections.

2. Plan the routing of the tubing.

A. If no legs are to be used, and the tubing must pass through the base, a hole in the counter top must be made prior to sealing the unit to the counter.

B. If using legs, the tubing may be routed through the bottom, or through the back as desired.

3. Plan the unit drain. Two  $\frac{3}{4}$ " I.D. drain tubes are located at the back inside of the cabinet. The tubes may drain the unit through the back or through the openings in the base. There are several different fittings shipped with the unit to allow different drain tube configurations.

4. In order to comply with National Sanitation Foundation (NSF) requirements, this unit must be either elevated above the counter top sufficiently to provide space for cleaning under the unit **or** sealed to the counter top.

Elevating the unit may be accomplished by using the optional leg kit (KLP5). They will screw into threaded holes in the base of the unit.

If the unit is to be sealed to the counter top, the drain and soda tubing should be available and planned such that the connections may be finished after the unit has been sealed to the counter.

Sealing may be accomplished by the use of room temperature vulcanizing (RTV) rubber sealant such as General Electric IS 808 Industrial Sealant, Dow Corning 731 or the equivalent.

With the unit located on the counter as desired:

A. Tilt or lift the unit to expose the bottom flanges of the base frame.

B. Apply the sealant to cover the bottom flanges of the base frame.

C. Return the unit to the desired position on the counter top.

D. Add sealant around the base frame and counter top to provide a seal with a radius of  $\frac{1}{2}$ ". Follow the sealant manufacturer's instructions on the package for working with the sealant, and cleaning up.

E. Seal around all access holes in the counter top with Permagum or Mortite caulk or an equivalent material.

**THE CABINET MUST BE  
LEVELED LEFT TO RIGHT  
AND FRONT TO BACK**

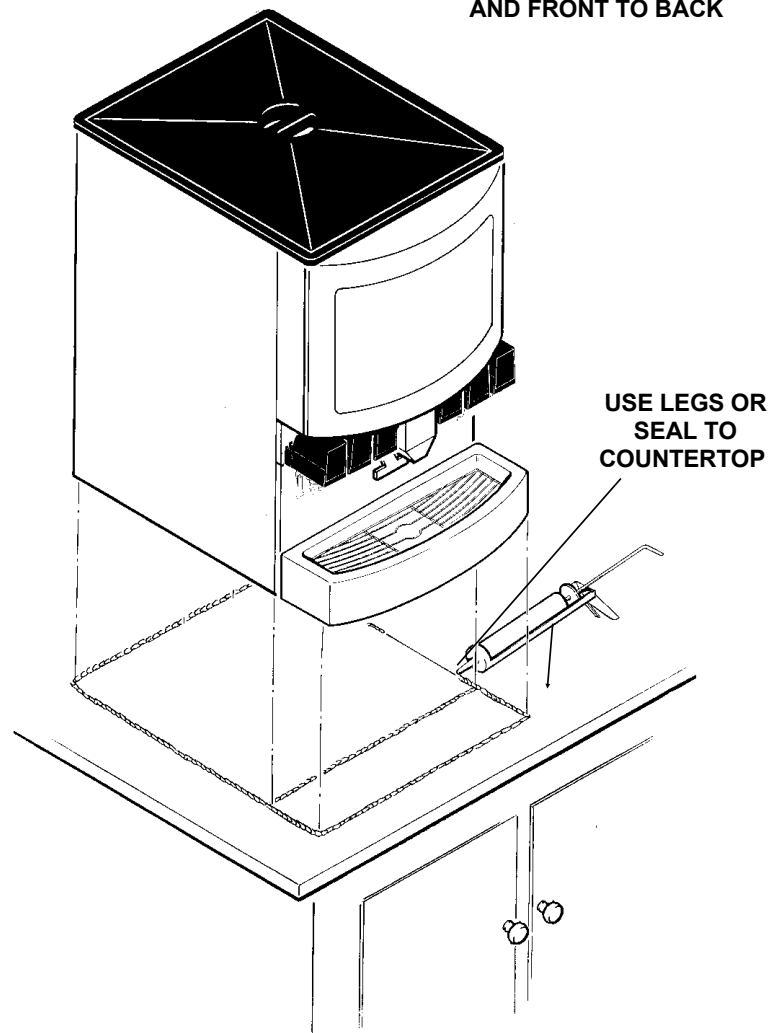

## FOR THE INSTALLER

1. If installing a carbonator, locate it nearby.
2. Route the drain lines to the building drain. Vent the drain tubes if installing at the back of the cabinet.
3. Locate electrical supply (for cord - 115v outlet).

The outlet must be properly grounded. The circuit must be fused and no other electrical appliance should be on the circuit.

### ALL ELECTRICAL WIRING MUST CONFORM TO NATIONAL AND LOCAL CODES

4. Remove any shipping materials.

Refer to the plumbing schematic on the back of the cabinet (all stub lines are labeled) and:

- A. Connect **three** (for 6 Valve Units) **or two** (for 8 valve units) carbonated water supply lines (field supplied) from the remote carbonator to the carbonated water stub line at the dispenser cold plate.
- B. Connect water supply line (field supplied) from building source to carbonator (filtered water is recommended).
- C. Connect a water supply line to the plain water stub line on the cold plate for use with the non-carbonated valve.

NOTE: If ALL valves need carbonation, connect an **additional** carbonated water line from the carbonator to the plain water stub line on the cold plate.

- D. Connect syrup lines to the cold plate syrup stub lines.

6. Connect primary CO<sub>2</sub> regulator to CO<sub>2</sub> tank. Secure secondary regulators to wall or other stationary surface.

7. Connect CO<sub>2</sub> line between outlet of primary regulator and inlet of secondary regulators.

8. Connect CO<sub>2</sub> lines between outlets of secondary regulators and syrup tanks. Or to syrup pumps in the case of Bag-In-Box.

### INSTALLING DRAIN AND SODA LINES

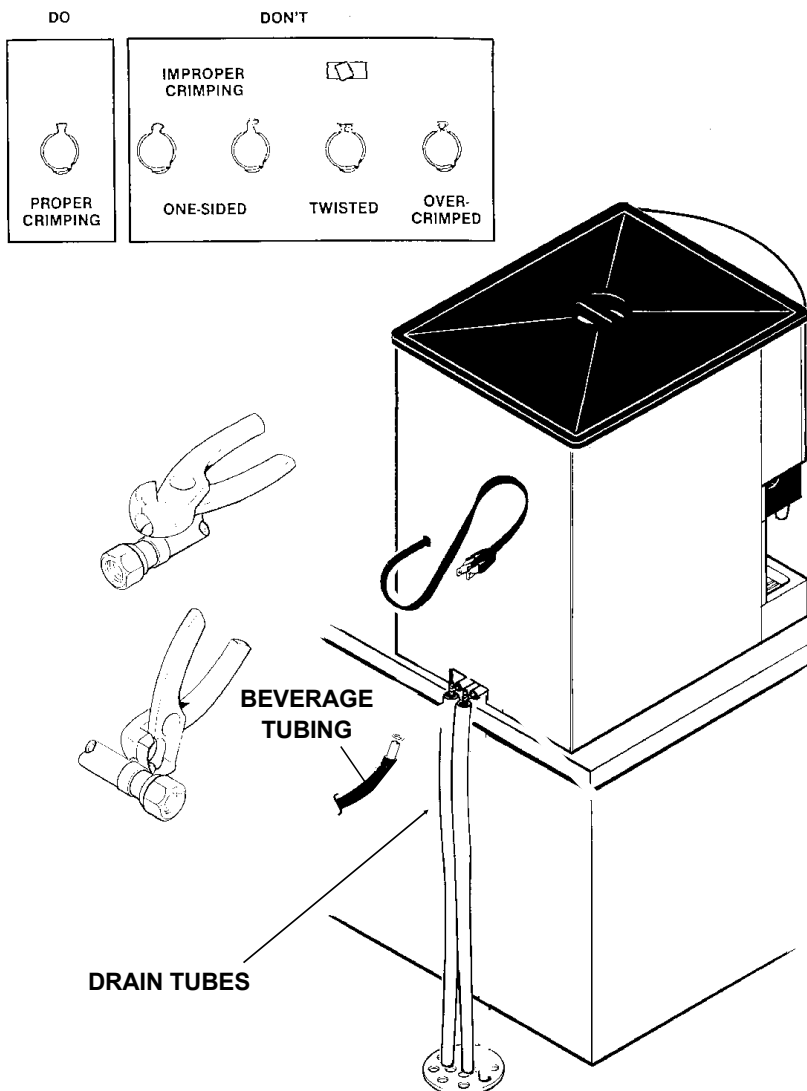

# RS100 and RS150

## SODA SYSTEM SCHEMATIC: 6 Valve Units

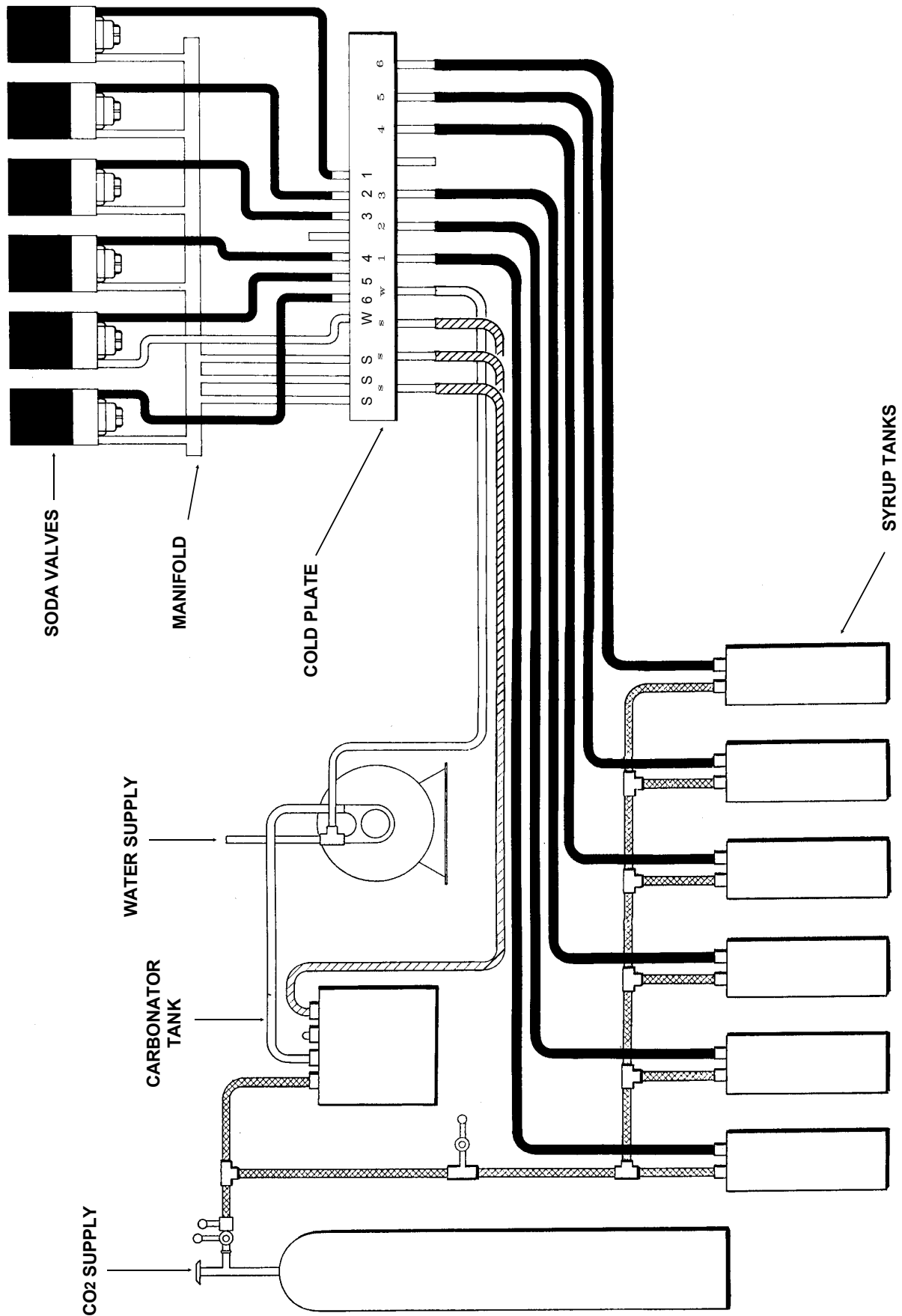

SODA SYSTEM SCHEMATIC: 8 Valve Units

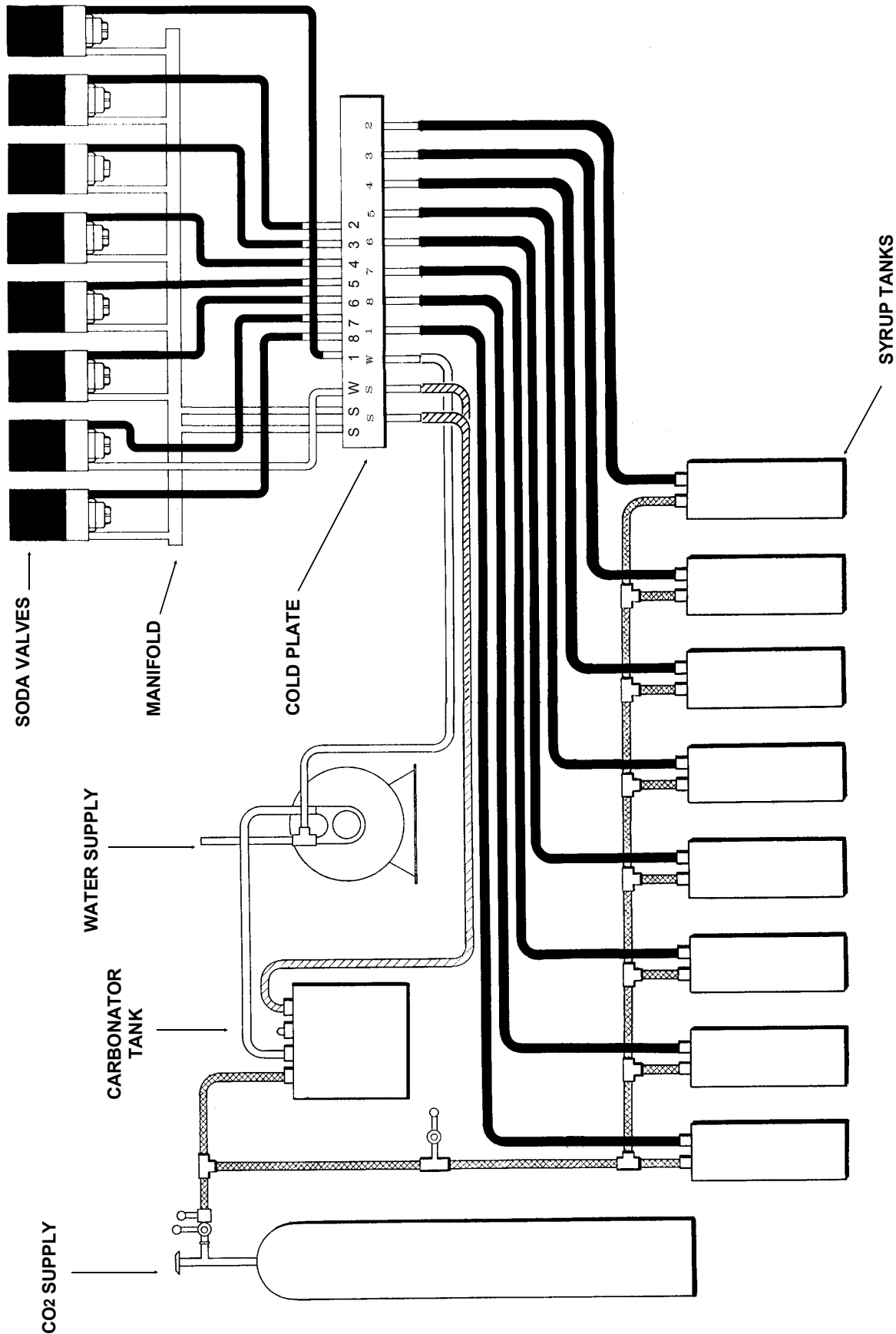

# RS100 and RS150

## HOW IT WORKS

The ice is stored in a hopper, and the hopper is sloped towards the front. At the front there is an angled rotor: when that rotor turns, it scoops ice up, lifts it to the top of the ice chute and drops it through that chute into the user's container.

Below the hopper is a cold plate (a block of aluminum with several circuits of stainless steel tubing molded within it). Ice from the hopper falls through slots in the bottom onto the top of the cold plate. Ice is dispersed across the cold plate because the cold plate is in the dispenser at an angle: the ice falls on the high end and slides down.

### CUT AWAY VIEW

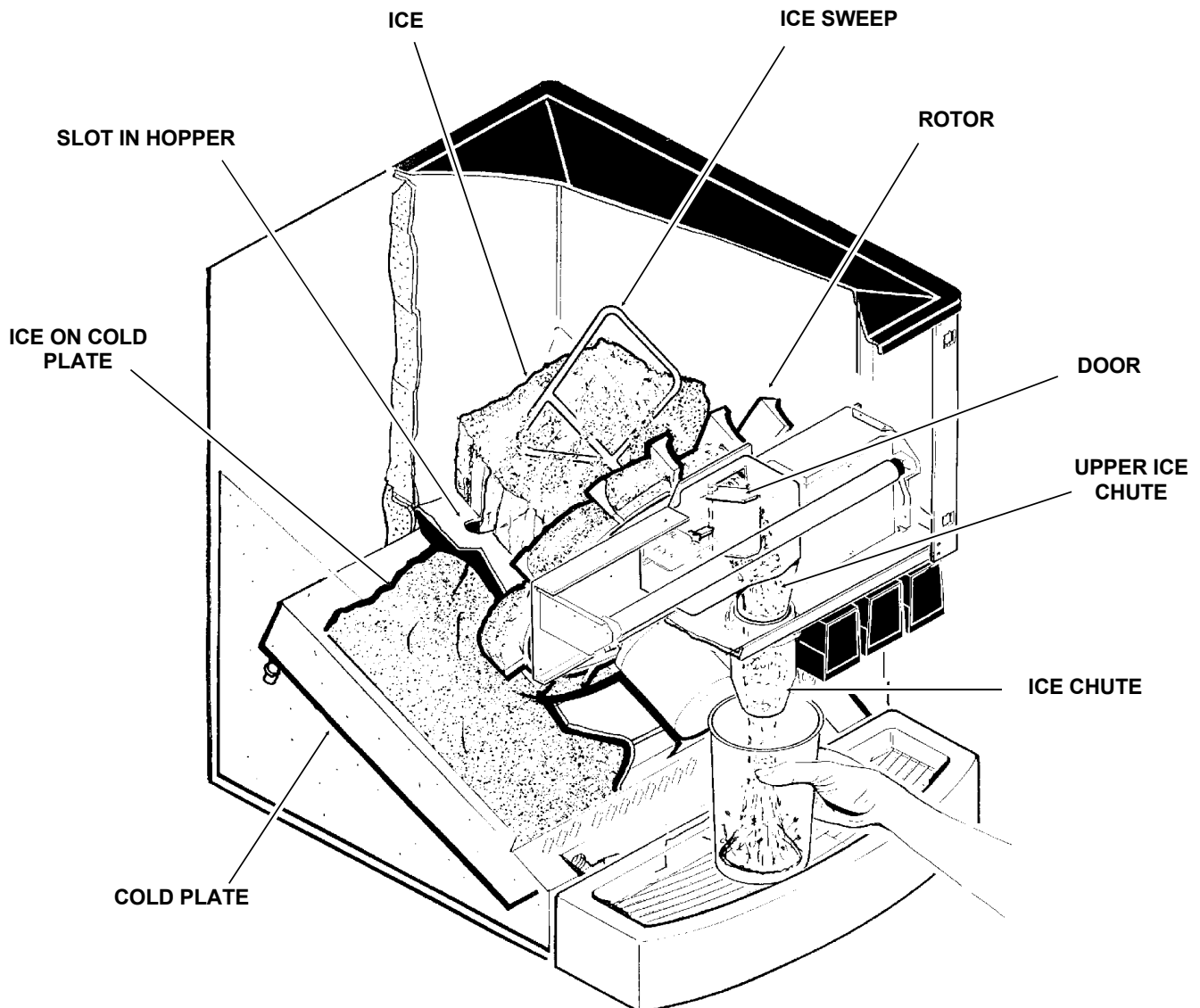



## INITIAL START UP

1. Turn on the CO<sub>2</sub>.
2. Set the high pressure regulator (to the carbonator) to 80-100 PSI.
3. Set the low pressure regulator to 40-50 psi. Set diet regulator (if used) to 10-15 psi.
4. Turn on the water to the carbonator.
5. Plug in or turn on the carbonator.
6. Purge CO<sub>2</sub> gas pressure from the carbonator tank once or twice while it is filling by pulling up on the pressure relief valve on the top of the tank.
7. Sanitize the ice storage system as instructed on page 13.
8. Turn the key switch to ON.

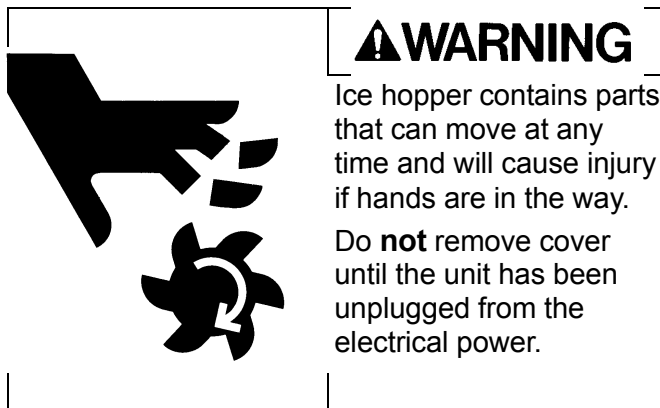

9. Fill hopper with sanitary ice.
10. Plug the unit's power cord into an electrical outlet, the lighted sign should come on. Dispense several containers of ice.
11. Activate soda valves until water is dispensed.
12. Check the primary CO<sub>2</sub> gauge for the carbonator, and the secondary CO<sub>2</sub> gauge for the syrup.
13. Connect the syrup containers to the soda system.
14. Activate the soda valves until syrup is dispensed with the water.

15. Leave the unit alone for about a half hour to cool the cold plate and soda product.
16. While waiting, check all connections for leaks, repair as required.
17. When cold plate has cooled, adjust each soda valve for the proper water to syrup ratio.

To remove valve covers:

- Pull off upper front panel.
- Twist clear ice chute 1/3 turn counterclockwise and pull down to remove.
- Slide ice chute mounting panel forward to remove from cabinet. Valve covers may now be removed. Reverse to reassemble when valves are adjusted.

Note: there is a timer in the control box that will activate the rotor in the ice bin every two hours. The amount of time that the rotor turns is adjustable between one tenth of a second and 4 seconds. The purpose for the timer is to agitate the ice to keep it from fusing together after long periods in the bin.

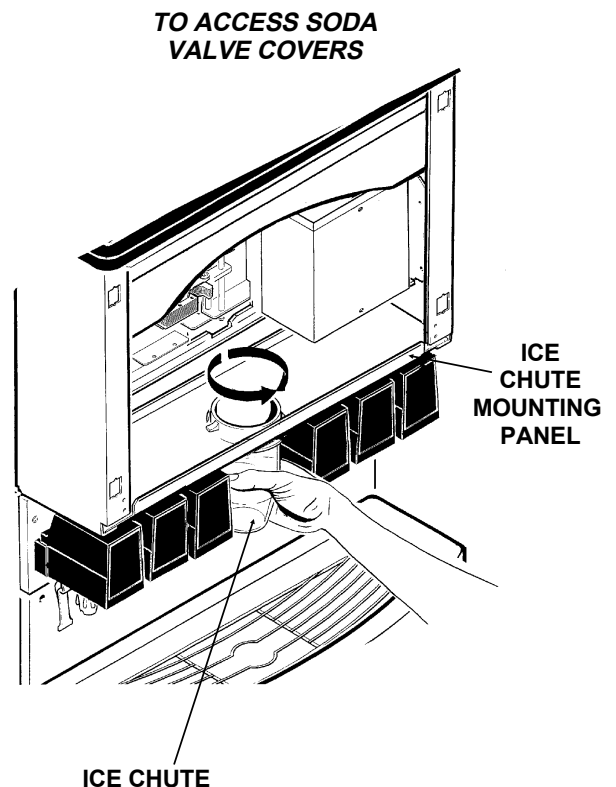

# RS100 and RS150 FOR THE OPERATOR

This section covers operating controls, daily pre-operation check, unit operation, adjustments, replenishing CO<sub>2</sub> and syrup supplies, and daily cleaning.

**OPERATING CONTROLS** - Units have **either** levers **or** push buttons

**Levers:** Dispensing valve levers, located below the dispensing valves, need only to be pressed with a cup or glass to dispense product.

**Ice:** Ice will continue to be dispensed for as long as the lever is held in, or until the hopper is empty.

**Push Buttons:** On the front of each valve will be a button, that when pushed, will activate the valve.

**Ice:** When the ice dispense button is pushed, ice will be dispensed for as long as the button is held in or until the hopper is empty.

## General Information

**Dispensing Soda:** To minimize foaming, a cup, 1/3 full of ice, should be filled at an angle so that the product runs down the inside wall of the cup, until the cup is nearly full.

When the ice dispense lever or button is pushed, a motor begins to turn the rotor in the hopper, and a solenoid opens the ice chute door. Ice is then dropped down through the ice chute.

**NOTE:** Periodically during the day, clean up the ice spilled in the drip tray.

There is a timer in the control box that will activate the rotor in the ice bin every two hours.

No ice will fall out because the ice chute door will remain closed. The amount of time that the rotor turns is factory set at 2 seconds, and is adjustable between one tenth of a second and 4 seconds.

The reason for the timer is to stir the ice so that it doesn't fuse together after long periods in the bin.

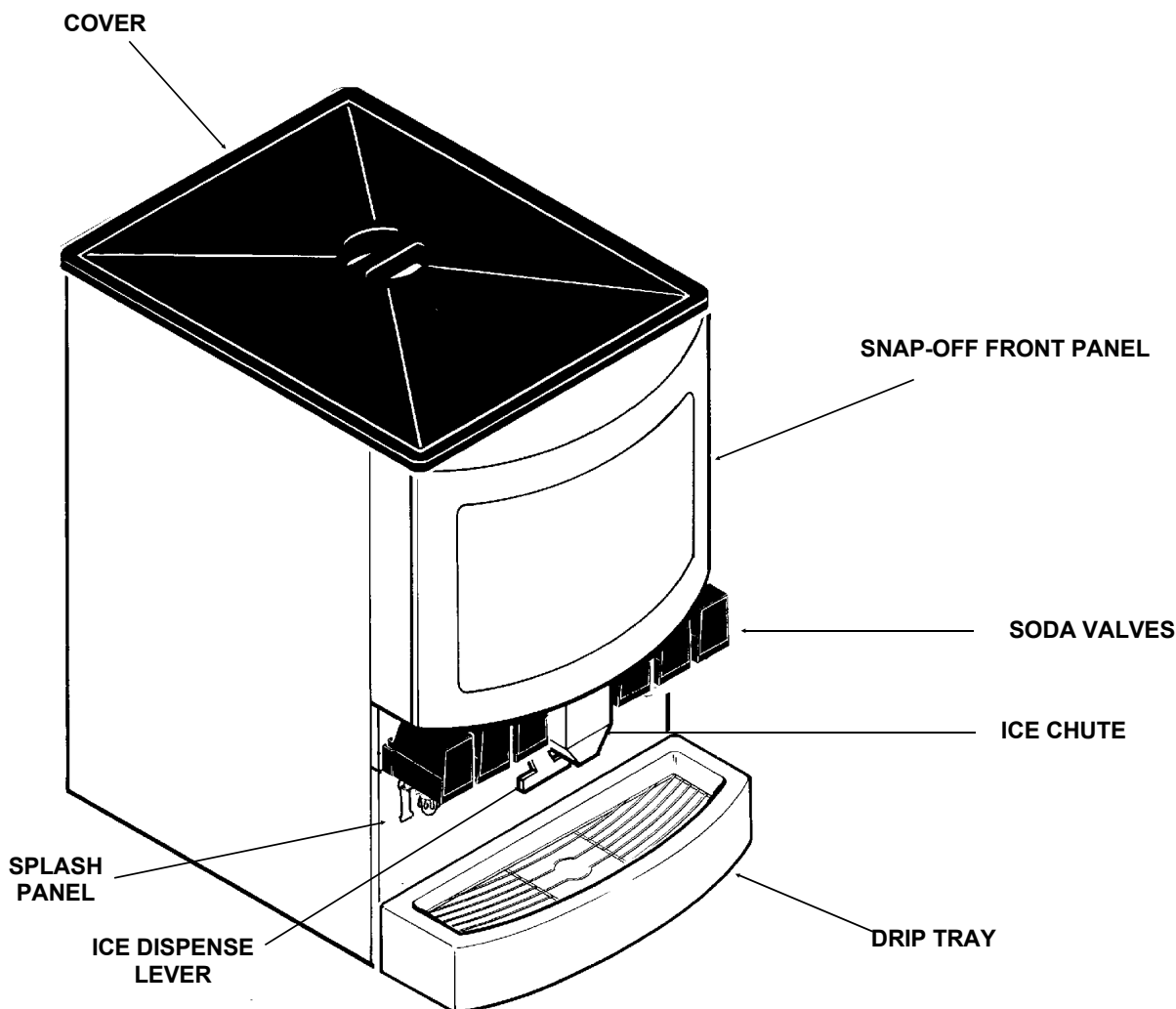

## FOR THE OPERATOR

### Daily Check

1. Make sure that the CO<sub>2</sub> cylinder primary regulator assembly 1800 psi gauge is not in the shaded ("change CO<sub>2</sub> cylinder") portion of the dial. If so, CO<sub>2</sub> cylinder is almost empty, and must be replaced.
2. Sufficient syrup supply in all syrup containers. If not, replenish syrup supply.
3. Make sure drip tray and grill are clean.
4. Make sure soda valve nozzles are clean.
5. Remove cover and pour sanitary ice into the hopper.



### **▲WARNING**

Ice hopper contains parts that can move at any time and will cause injury if hands are in the way.

Do **not** remove cover until the unit has been unplugged from the electrical power.

Do NOT use bagged ice directly from a freezer. The ice **must** be broken up in the bags first before adding to the hopper.

**Large chunks of ice can NOT be dispensed.**

The dispenser must always contain ice to have ice available for use, and to keep the syrup product cool. If there is no ice in the hopper, it will take about 1/2 hour after ice is added for the cold plate to cool off properly.

NOTE: After ice is loaded into a WARM hopper, dispense several containers of ice: this helps disperse the ice across the cold plate.

Keep the cover in place, and check the ice supply regularly during operating hours.

6. Keep drip tray clear of spilled ice

7. At the end of the day:

Remove soda valve nozzles and diffusers, clean them and soak in hot water.

Remove the grill from the drip tray, clean the drip tray, grill and splash panel, make sure the drain is open by pouring hot water into the drip tray. Return the grill to the drip tray.

**POUR HOT WATER DOWN DRIP TRAY EVERY DAY**

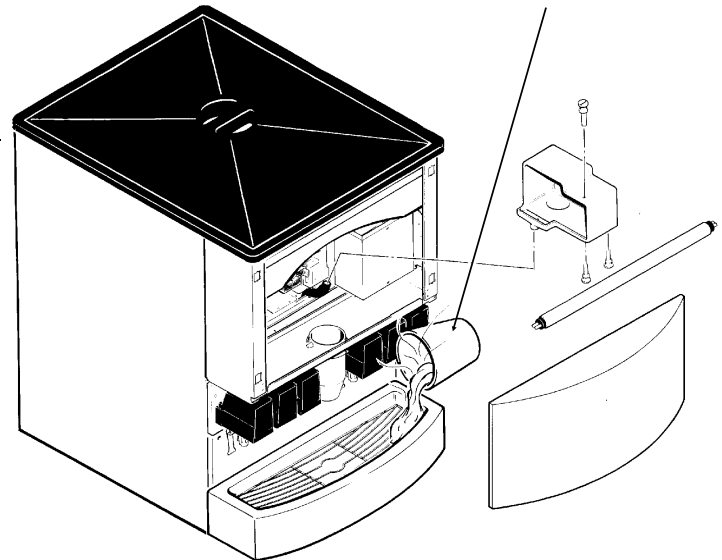

To avoid a delay in cooling soda at the beginning of the business day, make sure that the hopper is kept at least 1/4 full of ice to keep the cold plate (and the soda product) cold overnight.

# RS100 and RS150

## FOR THE OPERATOR

---

### Replenishing CO<sub>2</sub> Supply

Note: When indicator on CO<sub>2</sub> cylinder regulator 1800 psi gauge is in the shaded area, the cylinder is almost empty and should be changed.

1. Fully close (clockwise) CO<sub>2</sub> cylinder valve.
2. Slowly loosen CO<sub>2</sub> regulator assembly coupling nut allowing CO<sub>2</sub> pressure to escape, then remove regulator assembly from CO<sub>2</sub> cylinder.
3. Unfasten safety chain and remove empty CO<sub>2</sub> cylinder.

**If the CO<sub>2</sub> tank falls over, valve can become damaged or broken off, this can cause serious personal injury.**

**▲WARNING**

To avoid personal injury and/or property damage, always secure CO<sub>2</sub> cylinder with a safety chain to prevent it from falling over.

4. Position CO<sub>2</sub> cylinder and secure with safety chain.
5. Make sure gasket is in place inside CO<sub>2</sub> regulator coupling nut, then install regulator on CO<sub>2</sub> cylinder.

6. Open (counterclockwise) CO<sub>2</sub> cylinder valve slightly to allow lines to slowly fill with gas, then open valve fully to back seat valve. (Back seating valve prevents leakage around valve shaft.)

7. Check CO<sub>2</sub> connections for leaks. Tighten loose connections.

### Replenishing Syrup Supply.

1. Remove CO<sub>2</sub> disconnect and syrup disconnect from empty syrup tank, then remove tank.
2. Place full syrup tank in position, then connect CO<sub>2</sub> disconnect and syrup disconnect to full syrup tank.

### Syrup Flavor Change.

Contact beverage supplier to have soda circuit sanitized.

## CLEANING AND SANITIZING

The drip tray, grill and splash panel area should be cleaned daily.

The soda valve nozzles and diffusers should be cleaned weekly.

The ice storage system should be sanitized monthly.

### Daily:

1. Lift up and remove grill from drip tray.
2. Use mild soap, hot water, and a clean cloth to wash drip tray and splash panel; rinse with hot water, allowing plenty of hot water to run down the drain.
3. Wash the grill, then rinse with clean water. Place back in drip tray.
4. Clean all exterior surfaces of the unit with warm water and a sponge. Rinse out the sponge with clean water, wring excess water out of the sponge, and wipe off external surfaces of the unit. Wipe unit with a clean soft cloth. Do NOT use abrasive type cleaners.

### Weekly:

Clean valve nozzles & diffusers:

Looking down from the top of the unit, turn the nozzle clockwise about 1/8 turn; pull down to remove it.

Pull down to remove the diffuser.

Clean both with soap and water, rinse with potable hot water. Replace on the valve.

### BOOTH VALVE

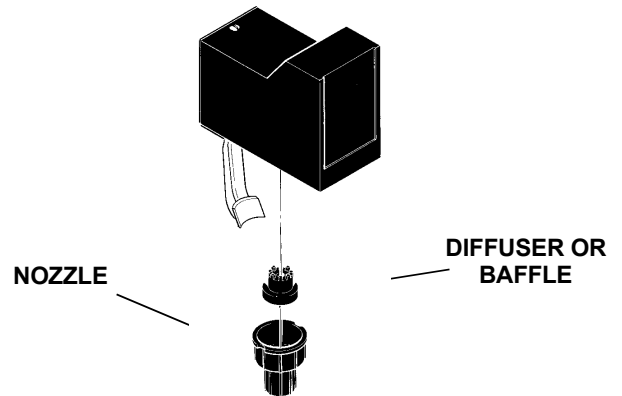

### CORNELIUS VALVE

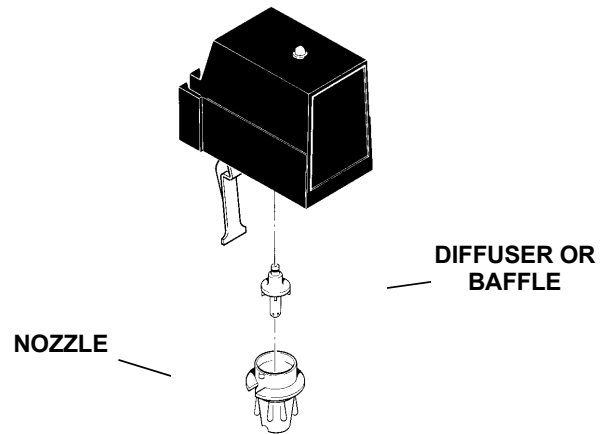

### DOLE VALVE

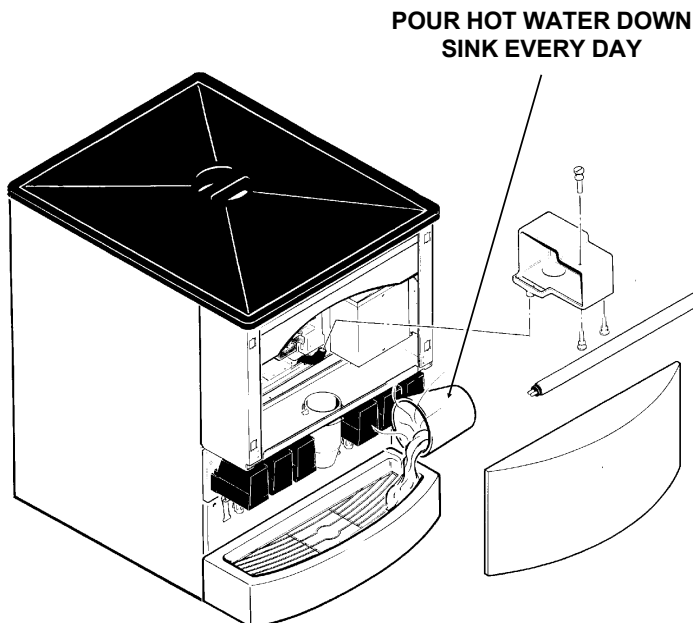
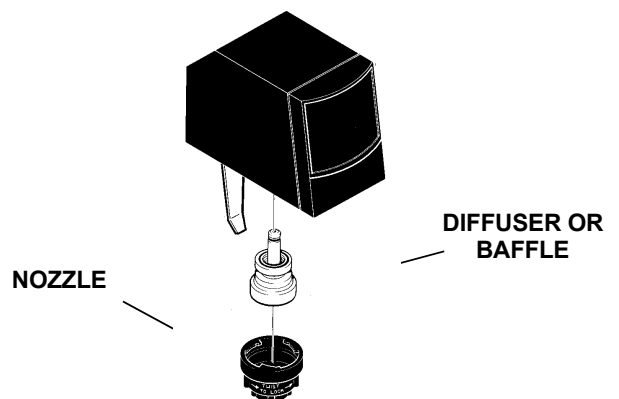

# RS100 and RS150

## CLEANING AND SANITIZING

### Monthly/Initial Start Up:

#### Sanitize the Ice Storage System.

Note: this should only be done by qualified personnel.

1. Unplug the Refreshment Stand's electrical cord from the electrical power.

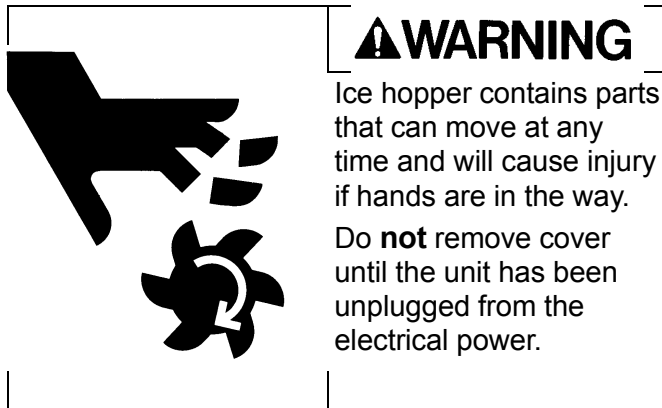

2. Remove cover and discard all remaining ice.

3. Mix a solution of 1 ounce of household bleach to 2 gallons of potable water, or: mix a solution of any approved sanitizer, following the directions for mixing and applying that sanitizer.

4. Unscrew the sweep arm from rotor shaft, and pull the rotor from hopper.

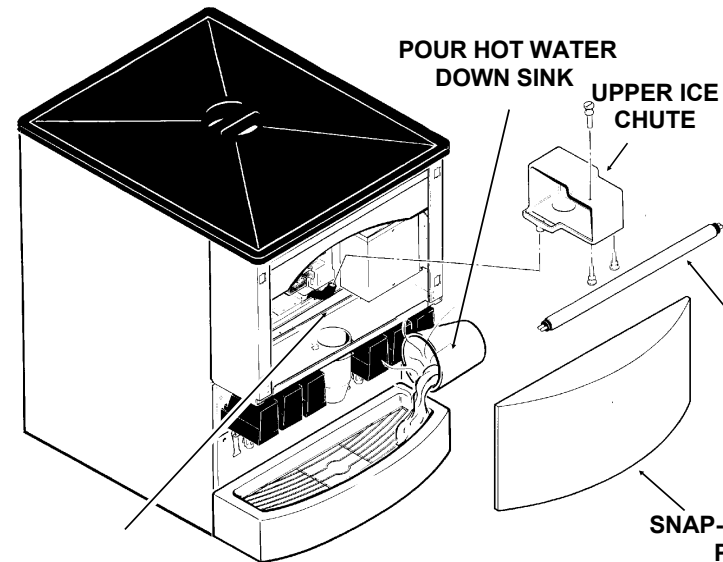
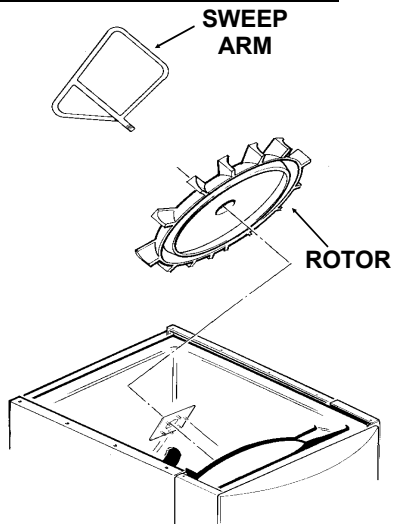

5. Using a clean cloth or sponge, wipe all interior surfaces of the ice storage hopper with the sanitizing solution, allow to air dry.

6. Wipe all surfaces of the rotor with the sanitizing solution, and allow to air dry.

7. Pull out and remove the upper front panel.

A. Twist the clear ice chute 1/3 turn, and pull down to remove.

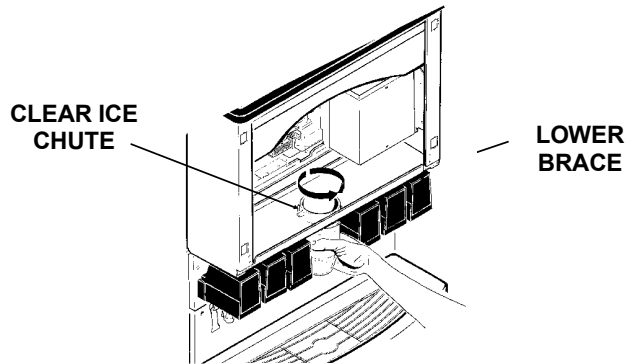

B. Locate the two thumb screws holding the lower brace: remove them and the brace.

C. Locate the three thumb screws holding the upper ice chute; remove them (1 on top and 2 below). Remove the upper ice chute from the machine.

Thoroughly wipe the surfaces of the bin door and both ice chutes with the sanitizing solution, and allow to air dry.

Place the lower brace back onto the unit, and secure with the two thumb screws.

Place the upper ice chute back onto the dispenser, secure with the three thumb screws.

Place the clear ice chute back onto dispenser. Place the upper front panel back onto the machine.

8. Wipe the inside surface of the cover with the sanitizing solution, and allow to air dry.

9. Reassemble the rotor and hopper, re-wipe the surfaces of the rotor and allow to air dry.

10. Wipe the top edge of the ice hopper with the sanitizing solution, allow to air dry.

11. Pour in fresh, sanitary ice and replace the cover. Plug the unit in, it is now ready to dispense ice  
Note: the cold plate is not in contact with the ice that is dispensed.

## SANITIZING SYRUP SYSTEM

### To Be Performed By Qualified Personnel Only

The procedure below is for the sanitation of one syrup circuit at a time. Repeat to sanitize additional circuits.

#### Materials Required:

- Sanitizing agent such as “Chlor-tergent” (Oakite products Co.) or “Diversal CX” (Diversey-Wyandotte Chemical Co.)
- An empty, clean syrup tank
- Plastic brush or soft cloth

Prepare the solution by dissolving the required amount of concentrate to supply 200 PPM (parts per million) available sanitizer in enough water to flush and sanitize the number of circuits to be sanitized, usually about 1 gallon per circuit. Water temperature should be between 75<sup>0</sup>F. and 125<sup>0</sup>F.

1. Locate the syrup tank for the circuit to be sanitized. Remove both quick disconnects from the syrup tank. Rinse quick disconnects in potable water.
2. Connect the machine side of the syrup disconnect to a clean syrup tank filled with the sanitizing solution.
3. Connect the CO<sub>2</sub> syrup tank supply hose to the sanitizer filled tank to pressurize.
4. Place a container under the soda valve to be cleaned. Actuate the valve to flush sanitizing solution through the syrup circuit. Dispense until only sanitizer is coming from the valve. Stop dispensing and allow the solution to remain in the system for an additional 15 minutes.

5. Remove the dispensing valve nozzle, and pull out the center mixing baffle.
6. Using plastic brush or soft cloth and sanitizing solution, scrub the nozzle, mixing baffle, bottom of dispensing valve, cup lever (if used). Rinse with potable water.
7. Reassemble mixing baffle and nozzle.
8. Actuate dispensing valve and allow 1/2 gallon of sanitizer to be dispensed.
9. Remove tank containing sanitizing solution from system and connect tank containing syrup into syrup system.
10. Place a container under the soda valve. Actuate the valve until only syrup is flowing from

**Flush sanitizing solution from syrup system.**

**▲ WARNING**

Residual sanitizing solution left in system could create a health hazard.

valve.

11. Flush all sanitizer solution from the syrup tank

**To avoid personal injury or property**

**▲ WARNING**

**damage, do NOT remove cover from the pressurized tank until all pressure has been released from the tank.**

containing it.

# RS100 and RS150

## SERVICE DIAGNOSIS

PROBLEM	PROBABLE CAUSE	CORRECTION
Dispensed product produces foam as it leaves dispensing valve.	1. No ice on cold plate.	1. Replenish ice supply, allow ice to contact cold plate for 1/2 hour to cool product.
	2. Carbonator CO <sub>2</sub> regulator pressure too high for existing water conditions or temperature.	2. Reduce carbonator CO <sub>2</sub> regulator pressure setting.
	3. Syrup over carbonated with CO <sub>2</sub> as indicated by bubbles in inlet syrup lines leading to the unit.	3. Remove syrup tank's quick disconnects. Relieve tank CO <sub>2</sub> pressure, shake tank vigorously, then relieve tank CO <sub>2</sub> pressure as many times as necessary to remove over carbonation.
	4. Dispensing valve restricted or dirty.	4. Sanitize syrup system as instructed.
	5. Dirty water supply.	5. Check water filter. Replace cartridge. NOTE: If the water supply is dirty, be sure to flush lines & carbonator completely. If needed, remove lines to carbonator tank, invert tank and flush tank and all inlet lines to remove any foreign particles or dirt.
Only carbonated water dispensed.	1. Quick disconnects not secure on syrup tanks.	1. Secure quick disconnects on syrup tanks.
	2. Out of syrup.	2. Replenish syrup supply as instructed.
	3. Syrup tank's secondary CO <sub>2</sub> regulator not properly adjusted.	3. Adjust syrup tanks secondary CO <sub>2</sub> regulator.
	4. Inoperable dispensing valve.	4. Repair or replace dispensing valve.
	5. Dispensing valve syrup flow regulator not properly adjusted.	5. Adjust dispensing valve.
	6. Dispensing valve, syrup tank disconnects, or syrup lines restricted.	6. Sanitize syrup system.
Only syrup dispensed.	1. Plain water inlet supply line shut off valve closed.	1. Open plain water inlet supply line valve.
	2. Carbonator power cord unplugged.	2. Plug carbonator in.
	3. Carbonator primary CO <sub>2</sub> regulator not properly adjusted.	3. Adjust carbonator primary CO <sub>2</sub> regulator.



## SERVICE DIAGNOSIS

PROBLEM	PROBABLE CAUSE	CORRECTION
Will not dispense ice	1. No ice in hopper	1. Fill hopper with ice
	2. Vend switch does not close	2. Check vend switch, replace if open
	3. Drive motor will not run	3. Check drive motor, and wiring connection, replace if not working
	4. Door solenoid will not open door	4. Check/replace door and solenoid
	5. Rotor will not turn	5. Check hub of rotor
	6. Relay for vend switch does not close during operation.	6. Check relays, replace if necessary.
Water to syrup ratio too low or too high	1. Dispensing valve syrup flow regulator not properly adjusted	1. Adjust water to syrup ratio
	2. CO <sub>2</sub> gas pressure to syrup tanks insufficient to propel syrup out of the tank	2. Adjust syrup tanks secondary CO <sub>2</sub> regulator
Adjustment of dispensing valve syrup flow regulator does not increase to desired water to syrup ratio	1. No syrup supply	1. Replenish syrup supply as needed.
	2. Syrup tank quick disconnects not secure	2. Secure quick disconnects
	3. Syrup tanks secondary CO <sub>2</sub> regulator out of adjustment.	3. Adjust syrup tanks secondary CO <sub>2</sub> regulator
	4. Dispensing valve syrup tank quick disconnect, or syrup line restricted.	4. Sanitize syrup system as instructed
Dispensed product carbonation too low	1. Carbonator primary CO <sub>2</sub> regulator out of adjustment for existing water conditions or temperature	1. Adjust carbonator primary CO <sub>2</sub> regulator
	2. Air in carbonator tank	2. Vent air out of carbonator tank through relief valve. Actuate dispensing valve until carbonator comes on.
	3. Water, oil, or dirt in CO <sub>2</sub> supply	3. Remove contaminated CO <sub>2</sub> . Clean CO <sub>2</sub> system (lines, regulators, etc.) using a mild detergent. Install a clean CO <sub>2</sub> supply.
No product (only water) dispensing from all valves	1. Out of CO <sub>2</sub>	1. Check CO <sub>2</sub> supply
Dispensed product comes out of the dispensing valve clear, but foams in the cup or glass	1. Oil film or soap scum in cup or glass	1. Use clean cups or glasses

# RS100 and RS150

## ELECTRICAL SEQUENCE

---

Refer to the wiring diagram.

### Ice Vending:

Ice is dispensed as long as the ice vend lever or push button is pushed, or until the hopper is empty of ice.

- When the ice vend lever or push button is pushed, the vend switch closes, and makes a circuit to the coil of relay A.
- When relay A is energized, relay A's contacts 6-9 and 7-4 close. Relay A's contacts 7-1 open.
- When relay A's contacts 6-9 close, they make a circuit to the door solenoid, which opens the ice door.
- When relay A's contacts 7-4 close, they make a circuit to the coil of relay B.
- When relay A's contacts 7-1 open, the circuit to the timer is opened.
- When relay B's coil is energized, it closes a circuit to the gearmotor, and the motor turns the rotor.

### Stand By:

- Relay A's contacts 7-1 are closed and make a circuit to the timer.
- The timer is energized when the unit is not dispensing. The timer switch will close for a few seconds every two hours.
- When the timer switch is closed, it makes a circuit to relay B's coil.
- When relay B is energized, it powers the gearmotor, and the rotor is turned.

### Soda Dispensing

Soda beverages are dispensed as long as the valve levers or push buttons are held in, and there is CO<sub>2</sub> and syrup.

- The key switch is closed, the circuit to all of the valves is enabled.
- When a valve lever or push button is pushed in, the valve switch will close, making a circuit to the coils of the valve which opens it.

## MOVING

If the dispenser is going to be moved to another building, shipped any distance, or if there is any possibility that it may be exposed to freezing temperatures, it must be thoroughly cleared of all liquids to prevent damage.

1. Sanitize syrup system as instructed on page 15.
2. Shut off water supply.
3. Unplug carbonator.

4. Remove connectors from syrup tanks.
5. Connect an empty syrup tank to one circuit.
6. Actuate valve on that circuit until only CO<sub>2</sub> (gas) flows from it.
7. Repeat steps 5-6 for all valves.
8. Remove all ice
9. Drain all water from bin and drain circuit.
10. Remove all field connections from cold plate.

## REMOVAL & REPLACEMENT

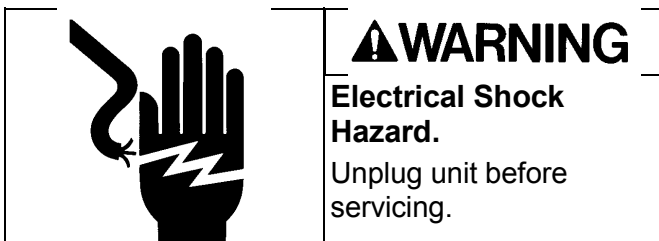

### To Replace Vend Switch:

1. Disconnect Electrical Power.
2. Pull out and remove upper front panel.

#### Lever Type Actuation:

- A. Twist ice chute 1/3 turn and pull down to remove.
- B. Remove screws holding valve mounting plate to cabinet. Pull valve and plate assembly out and away from cabinet. Switch is mounted to valve plate.

Reverse steps to reassemble.

#### Push Button Actuation:

Locate vend switch behind push button assembly of upper front panel.

3. Remove wires from switch.
4. Remove screw and nut retaining switch to mounting plate, and remove switch from dispenser.
5. Reverse steps to reassemble.

### To Replace Gear Motor Assembly:

1. Disconnect electrical power.
2. Remove cover from hopper.
3. Unscrew sweep arm holding rotor to gearmotor shaft.
4. Remove rotor from gearmotor shaft.
5. Remove splash panel
6. Twist ice chute 1/3 turn and pull down to remove.
7. Remove ice chute mounting plate.
8. Remove screws holding valve mounting plate to cabinet. Pull valve assembly out and away from cabinet.
9. Mark location of gearmotor bracket on cabinet.
10. Disconnect gearmotor electrical leads in control box
11. Remove (4) screws holding gearmotor to bracket.
12. Remove (4) screws holding gearmotor bracket to cabinet.
13. Swing gearmotor bracket out of cabinet.
14. Pull gearmotor from cabinet.
15. Reverse to reassemble. Gearmotor bracket should be installed where it was, so that the rotor should clear bin surface by 1/8" to 1/4". If needed, the slots on the gearmotor bracket will allow the position of the rotor to be adjusted.

# RS100 and RS150

## REMOVAL & REPLACEMENT

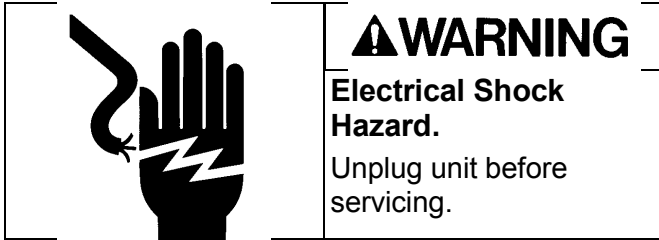

### To Replace Solenoid:

1. Disconnect electrical power.
2. Pull out and remove upper front panel. Remove fluorescent tube
3. Remove 2 thumb screws holding lower brace and remove.
4. Remove 3 thumb screws holding upper ice chute cover, and remove cover. Remove the metal solenoid cover.
5. Disconnect electrical leads from solenoid.
6. Straighten cotter pin, and remove pin from solenoid plunger.
7. Remove rubber mounting screws holding solenoid to cabinet, and remove solenoid from cabinet.

8. Reverse to reassemble.

### To Replace Light: (Optional)

1. Disconnect electrical power.
2. Pull out and remove upper front panel.
3. Twist fluorescent tube out of sockets.

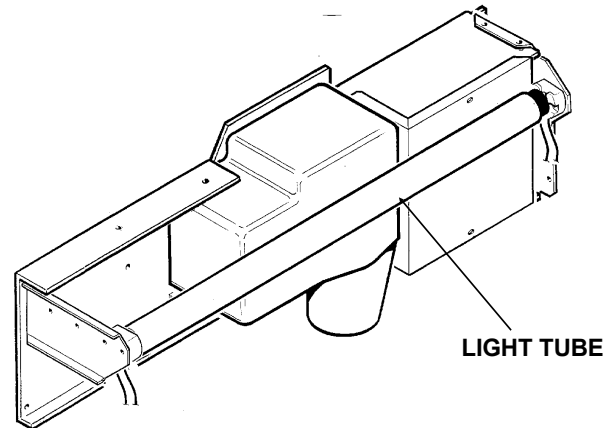

4. Reverse to reassemble.