

INTRODUCTION

This service manual is intended as a reference for the installer, user, and service agent of this Scotsman Refreshment Stand. It includes the necessary information to install, start up, operate, clean and maintain this unit.

TABLE OF CONTENTS

SPECIFICATIONS	2
FOR THE INSTALLER: Installation Of Loose Shipped Parts	3
FOR THE INSTALLER: Tubing Installation	4
FOR THE INSTALLER: Sealing of Cabinet	5
FOR THE INSTALLER	6
Installation: Scotsman CM Cuber	7
Installation: Scotsman Slim Line Cuber	8
SODA SYSTEM SCHEMATIC: 6 Valve Units	9
SODA SYSTEM SCHEMATIC: 8 Valve Units	10
HOW IT WORKS	11
INITIAL START UP	12
FOR THE OPERATOR	13
CLEANING AND SANITIZING	16
SANITIZING SYRUP SYSTEM	18
SERVICE DIAGNOSIS	19
SERVICE DIAGNOSIS	20
ELECTRICAL SEQUENCE	21
MOVING	22
REMOVAL & REPLACEMENT	22

This manual contains important information, read it before installation or operation.

Keep it for future reference.

It marks important safety information on a hazard that might cause serious injury.



RS160 and RS220 SPECIFICATIONS

The term "Refreshment Stand" means a machine that stores ice in an insulated, sanitary container; upon demand it dispenses that ice into a cup or glass; it cools beverages using ice falling from the hopper onto a cold plate at the base of the hopper; and it dispenses beverages via post-mix or pre mix valves. Some of the valves are not carbonated; they may be changed to carbonated if desired. Power to operate the valves may be shut off by a key switch.*

* Premix is not electrically powered.

The RS requires additional equipment to be functional:

An ice machine or source of sanitary ice; a carbonator for post mix (and potable water); a syrup delivery system, either pressurized syrup cans or bag-in-a-box; and CO₂. The dispenser must also be connected to a drain.

NOTE: This Refreshment Stand is designed to dispense cubed ice only. **Flaked or Nugget ice will not work.**

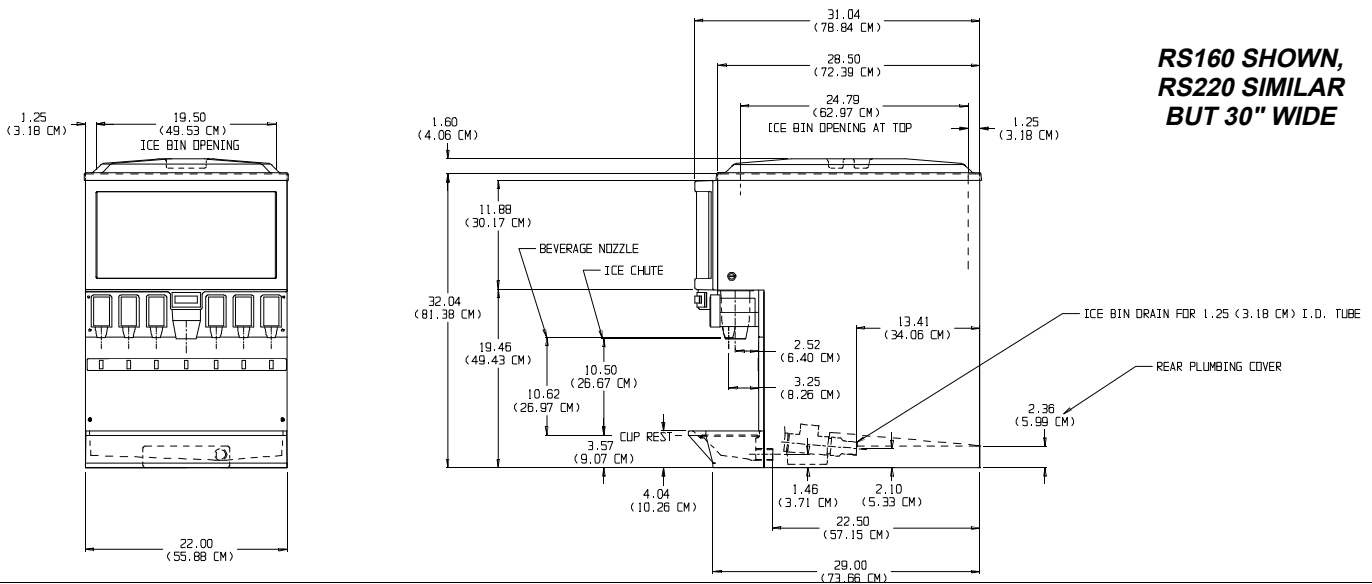

Base Model	Width	Total Ice Storage Capacity	Basic Electrical	Amperage	Power Cord
RS160	22"	160 lb.	115/60/1	2 amps	4' with plug
RS220	30"	220 lb.	115/60/1	2 amps	4' with plug

Rotor motor is 1/10 HP.

Options: Fast flow carbonator (100 G.P.H.). May be obtained as push button actuation for ice and soda or lever actuation for ice & soda. Both are factory installed. Various brand standard or fast flow post-mix valves are available (factory installed). Also available in premix with Booth Capre valves only (factory installed).

Cubed ice machines may be stacked onto the top of the dispenser with an adapter kit:

- RS160: Scotsman cubers SLE300, SLE400 or SLE400R use kit # KADUN2.
- RS220: Scotsman cubers CME250, CME256, CME500, CME506, CME650 OR CME656 use kit # KADCM2.

Scotsman Drink Systems are designed and manufactured with the highest regard for safety and performance. They meet or exceed the standards of U.L. and N.S.F.

Scotsman assumes no liability or responsibility of any kind for products manufactured by Scotsman that have been altered in any way, including the use of any parts and/or other components not specifically approved by Scotsman

Scotsman reserves the right to make design changes and/or improvements at any time. Specifications and designs are subject to change without notice.

RS160 and RS220

FOR THE INSTALLER: Installation Of Loose Shipped Parts

Several components are packed inside the hopper:

- Drip tray and grill
- 2 drain hoses
- Several hose clamps
- Several barbed hose fittings
- Fluorescent tube
- Lever (for lever models)

Remove them and set them aside for installation.

Ice lever/Ice Chute/Fluorescent Tube

1. Lift up and pull out to remove upper front panel.
2. Slide out ice chute mounting panel.
3. Insert the ice lever in to the valve panel through the slot as shown.
4. Swing the ice lever through from right to left and let it hang freely.
5. Twist the fluorescent tube into the sockets.
6. Replace ice chute mounting panel.
7. Insert clear ice chute into the panel and twist clockwise 1/3 turn.
8. Replace the upper front panel.

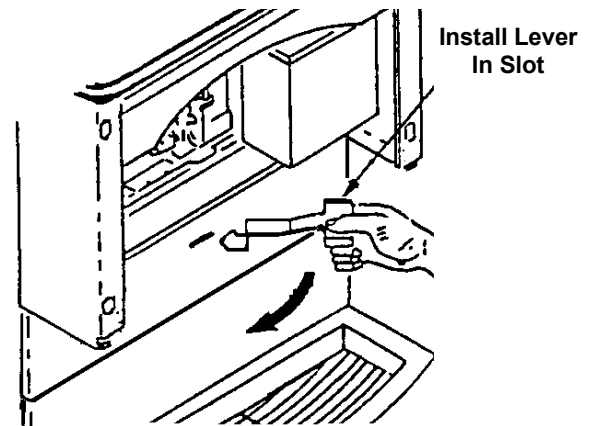
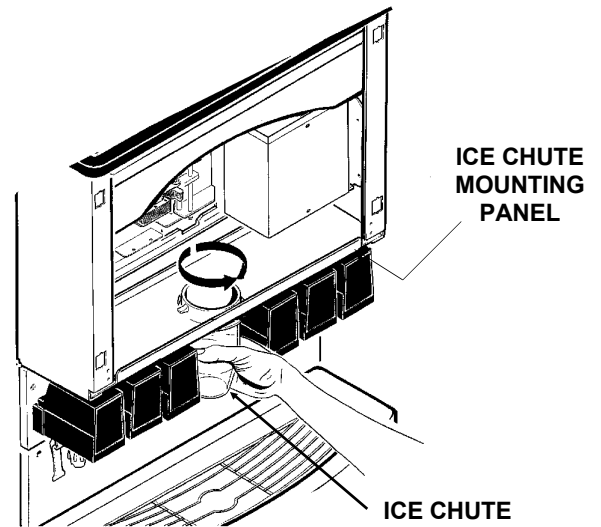

RS160 TOP VIEW (For Reference)

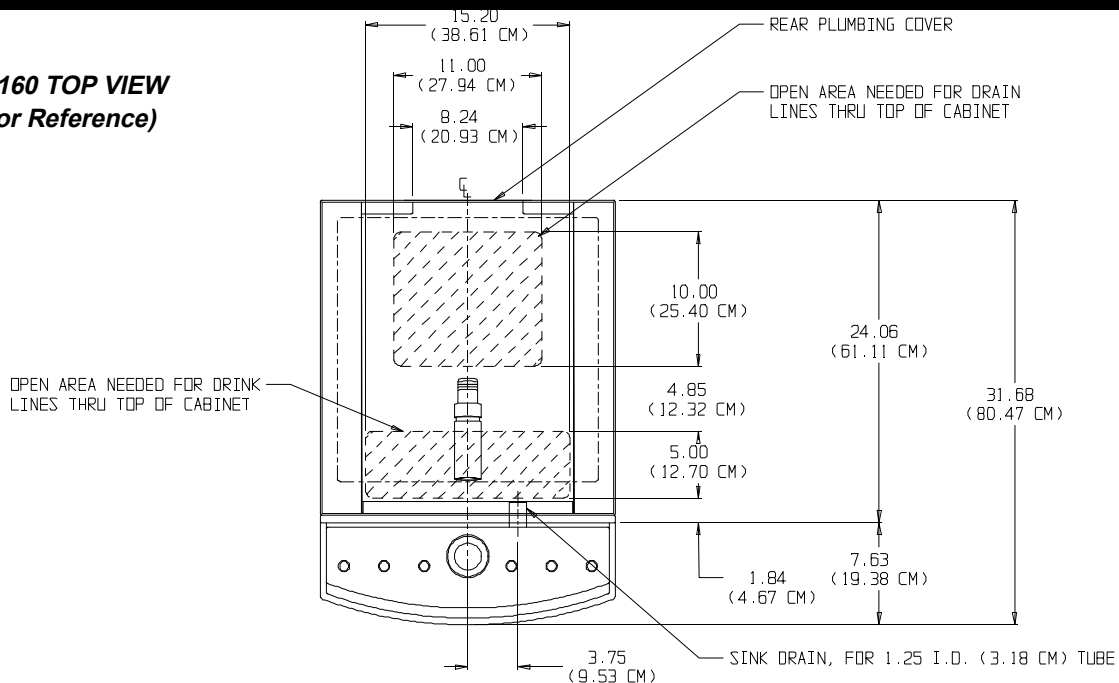

RS160 and RS220

FOR THE INSTALLER: Tubing Installation

1. Locate the dispenser on the counter. Allow vertical clearance above unit for the removal of the cover, and for pouring ice into the hopper.

Note: If installing an ice cube machine on top, check for proper total cabinet clearance, including adapter kit.

The syrup and carbonated water connections need to be made at the cold plate's stub lines. The cold plate stub lines are behind the splash panel.

Tubing routing to the cold plate is from either the back of the unit, or through openings in the base.

A plumbing circuit schematic diagram is on the back of the cabinet, refer to it for cold plate connections.

2. Plan the routing of the tubing (drain and soda).

If the tubing will pass through the base, a hole in the counter top must be made prior to sealing the unit to the counter.

The tubing may also be routed through the back.

3. Connect the drain system. There are two drains to connect: The sink (or drip tray) drain and the cold plate drain. They must be routed separately. The tubes may drain the unit through the back or through the openings in the base.

The cold plate drain tube is the one with the foam insulation on it. Tilt or lift the unit to expose the bottom of the dispenser.

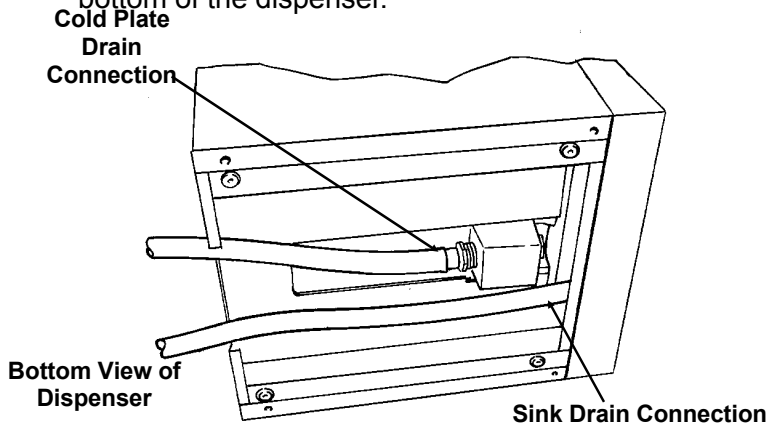

Connect the threaded drain fitting (packed loose in the hopper) to the cold plate drain connection.

Connect the cold plate drain tube to this fitting, route the hose to the building drain.

Install the sink drain after the machine has been set in place.

Drip Tray/Grill

1. Remove splash panel from unit.

2. Connect the sink drain hose to the sink drain fitting and secure it with a hose clamp. Route the tube to the building drain. Follow all local plumbing codes.

4. Hang the drip tray onto the metal tabs on the base of the unit.

5. Replace the splash panel.

Note: If the cabinet has been sealed to the countertop, add sealant around the sink and counter top to provide a seal with a radius of 1/2". Follow the sealant manufacturer's instructions on the package for working with the sealant, and cleaning up.

SIDE VIEW OF DRIP TRAY INSTALLATION

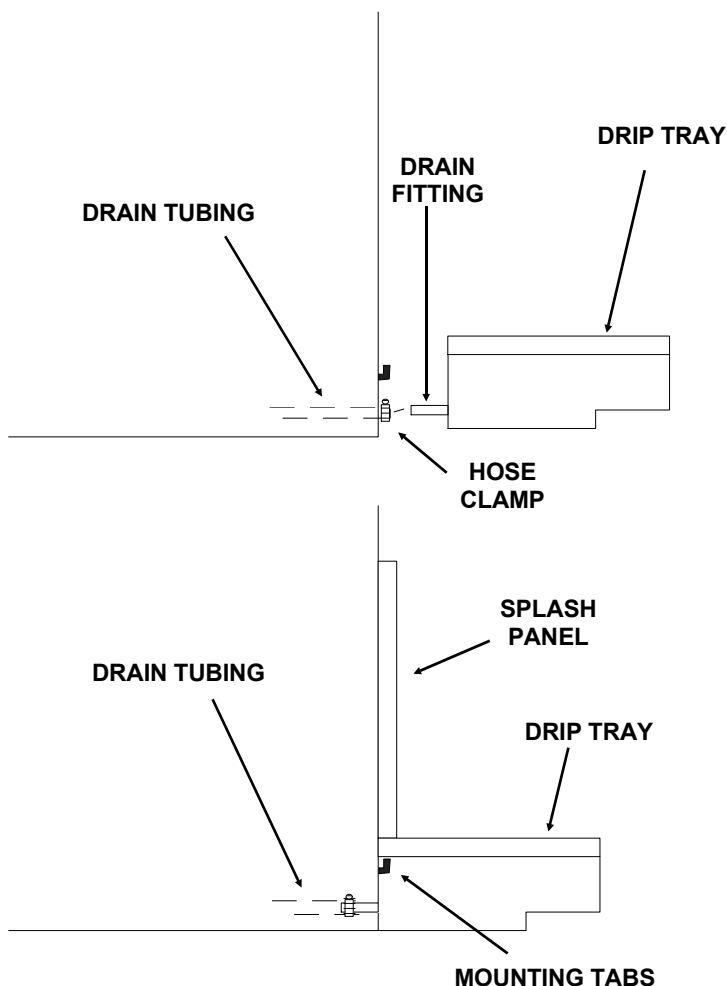

FOR THE INSTALLER: Sealing of Cabinet

In order to comply with National Sanitation Foundation (NSF) requirements, this unit must be either elevated above the counter top sufficiently to provide space for cleaning under the unit or sealed to the counter top.

Elevating the unit may be accomplished by using the leg kit. Legs screw into threaded holes in the base of the unit.

If the unit is to be sealed to the counter top, the soda tubing installation should be planned such that its connections may be finished after the unit has been sealed to the counter.

Seal the unit by the use of room temperature vulcanizing (RTV) rubber sealant such as General Electric IS 808 Industrial Sealant, Dow Corning 731 or the equivalent.

With the unit located on the counter as desired:

- A. Tilt or lift the unit to expose the bottom flanges of the base frame.
- B. Apply the sealant to cover the bottom flanges of the base frame.
- C. Return the unit to the desired position on the counter top.
- D. Add sealant around the base frame and counter top to provide a seal with a radius of 1/2". Follow the sealant manufacturer's instructions on the package for working with the sealant, and cleaning up.
- E. Seal around all access holes in the counter top with Permagum or Mortite caulk or an equivalent material.

**THE CABINET MUST BE
LEVELED LEFT TO RIGHT AND
FRONT TO BACK**

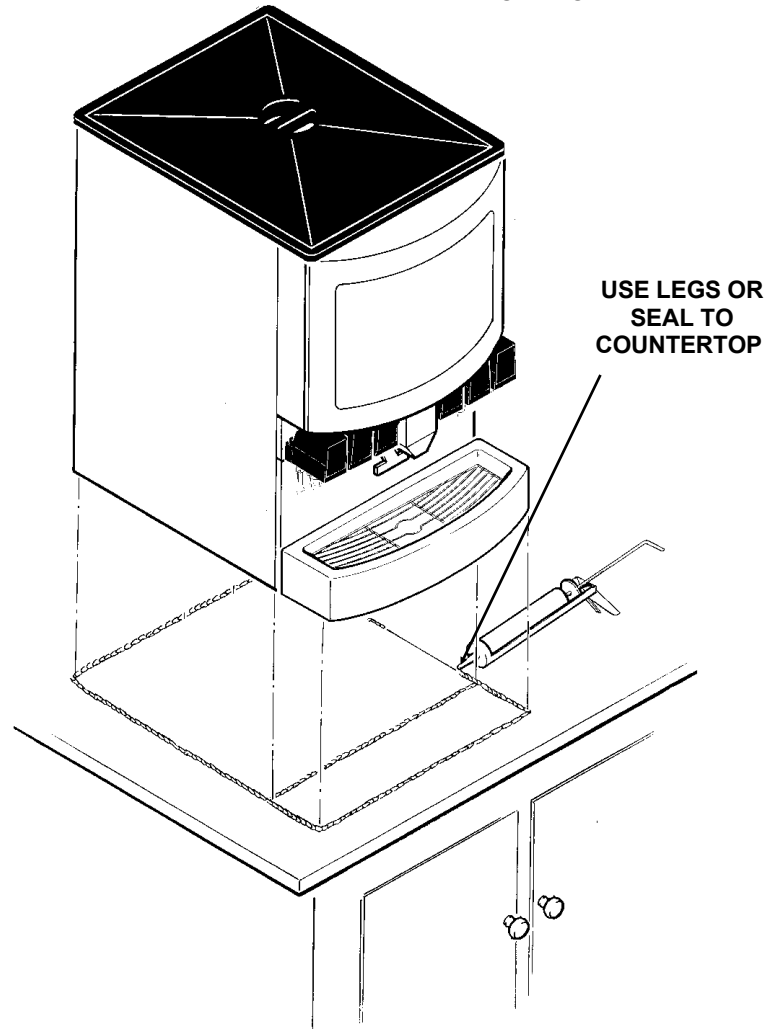

RS160 and RS220 FOR THE INSTALLER

1. If installing a carbonator, locate it nearby.
2. Route the drain lines to the building drain. Vent the drain tubes if installing at the back of the cabinet.
3. Locate electrical supply (for cord - 115v outlet).

The outlet must be properly grounded. The circuit must be fused and no other electrical appliance should be on the circuit.

ALL ELECTRICAL WIRING MUST CONFORM TO NATIONAL AND LOCAL CODES

4. Remove splash panel.

Refer to the plumbing schematic on the back of the cabinet (all stub lines are labeled) and:

Typical Installation

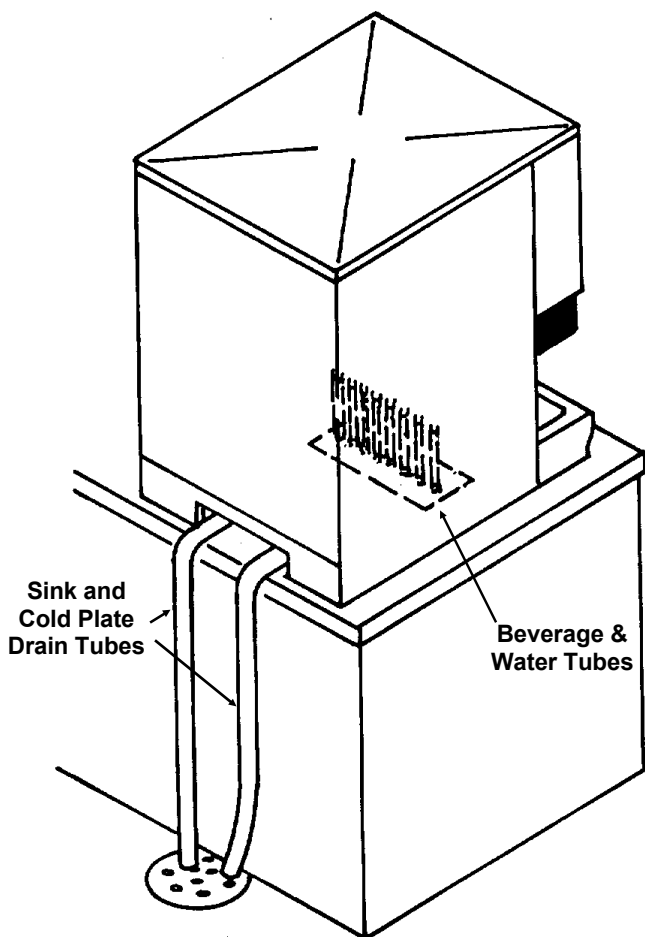

A. Connect carbonated water supply lines (field supplied) from the remote carbonator to the carbonated water stub line at the dispenser cold plate.

B. Connect water supply lines (field supplied) from building source to carbonator (filtered water is recommended).

C. Connect water supply line(s) to the plain water stub line(s) on the cold plate for use with the non-carbonated valve.

NOTE: If ALL valves need carbonation, connect an **additional** carbonated water line from the carbonator to the plain water stub line on the cold plate.

D. Connect syrup lines from the syrup supply to the cold plate syrup stub lines.

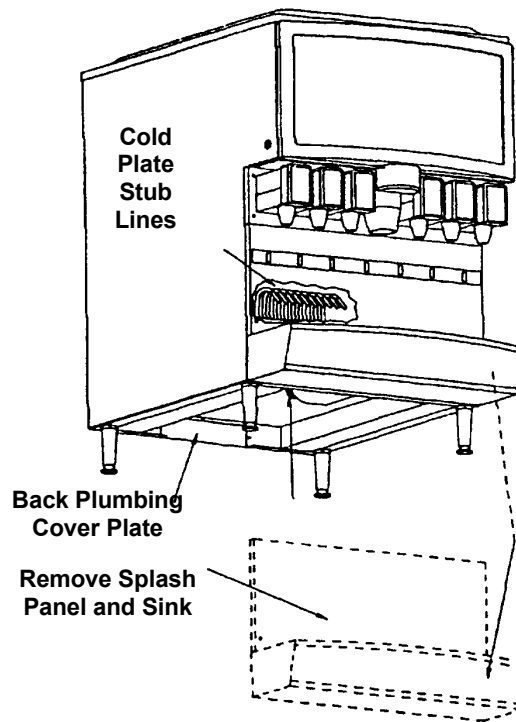

6. Connect primary CO₂ regulator to CO₂ tank. Secure secondary regulators to wall or other stationary surface.

7. Connect CO₂ line between outlet of primary regulator and inlet of secondary regulators.

8. Connect CO₂ lines between outlets of secondary regulators and syrup tanks. Or to syrup pumps in the case of Bag-In-Box.

Installation: Scotsman CM Cuber

1. Make sure the counter the dispenser is placed on is structurally able to hold the combined weight of the dispenser, ice and ice machine.
2. Install the dispenser.
3. Remove the dispenser cover (save it - it will be needed if the ice machine is removed).
4. Place stainless steel adapter sleeve onto the top of the dispenser.
5. Using the tube of sealant from the kit, place a bead of sealant onto the top edges of the area on the adapter where the ice machine will go.
6. Place a bead of sealant onto the inside and outside seams where the dispenser and adapter meet.
7. Using a mechanical lift, hoist the ice machine onto the dispenser, center left to right and align flush to the back.
8. Install a bin thermostat bracket assembly onto the underside of the CM ice machine.

Note: Thermostat bracket only required by CM250, CME250, CM500, CME500, CM650 or CME650.
9. Fasten together at the back of the machine using bolts from the ice maker and mounting straps from the kit.
10. Place the front cover plate onto the dispenser in front of the ice machine.

RS160 and RS220

Installation: Scotsman Slim Line Cuber

Assembly:

The assembly of the ice machine onto the dispenser requires two additional parts: an adapter and a thermostat stand off kit.

1. Mark two spots on the inside left liner of the dispenser: 2" down from the top, 4" from the back, and 4" apart.
2. At the two marked spots, drill two 1/4" holes thru the plastic liner only.
3. From the stand off kit, locate the stand offs and plastic anchors. Thread the stand offs partially into the plastic anchors.
4. Push the anchors/stand offs into the holes
5. Screw the stand offs all the way into the anchors. Be sure that the holes in the stand offs are horizontal.
6. Place a bead of silastic (from the kit) around the stand offs.
7. From the adapter kit, place the stainless steel adapter onto the top of the dispenser. Follow all directions included with the kit.
8. After the ice machine has been placed on the dispenser, remove the front panel and uncoil all of the bin thermostat capillary tube.
9. Route the capillary tube thru the front hole in the base of the ice machine, to the left side if the dispenser towards the stand offs.
10. Route the end of capillary tube thru the stand-offs, bend the tube around the stand offs so that it does not fall off.
11. Check that the routing of the capillary tube is away from the ice chute and up high enough near the base of the ice machine.

SODA SYSTEM SCHEMATIC: 6 Valve Units

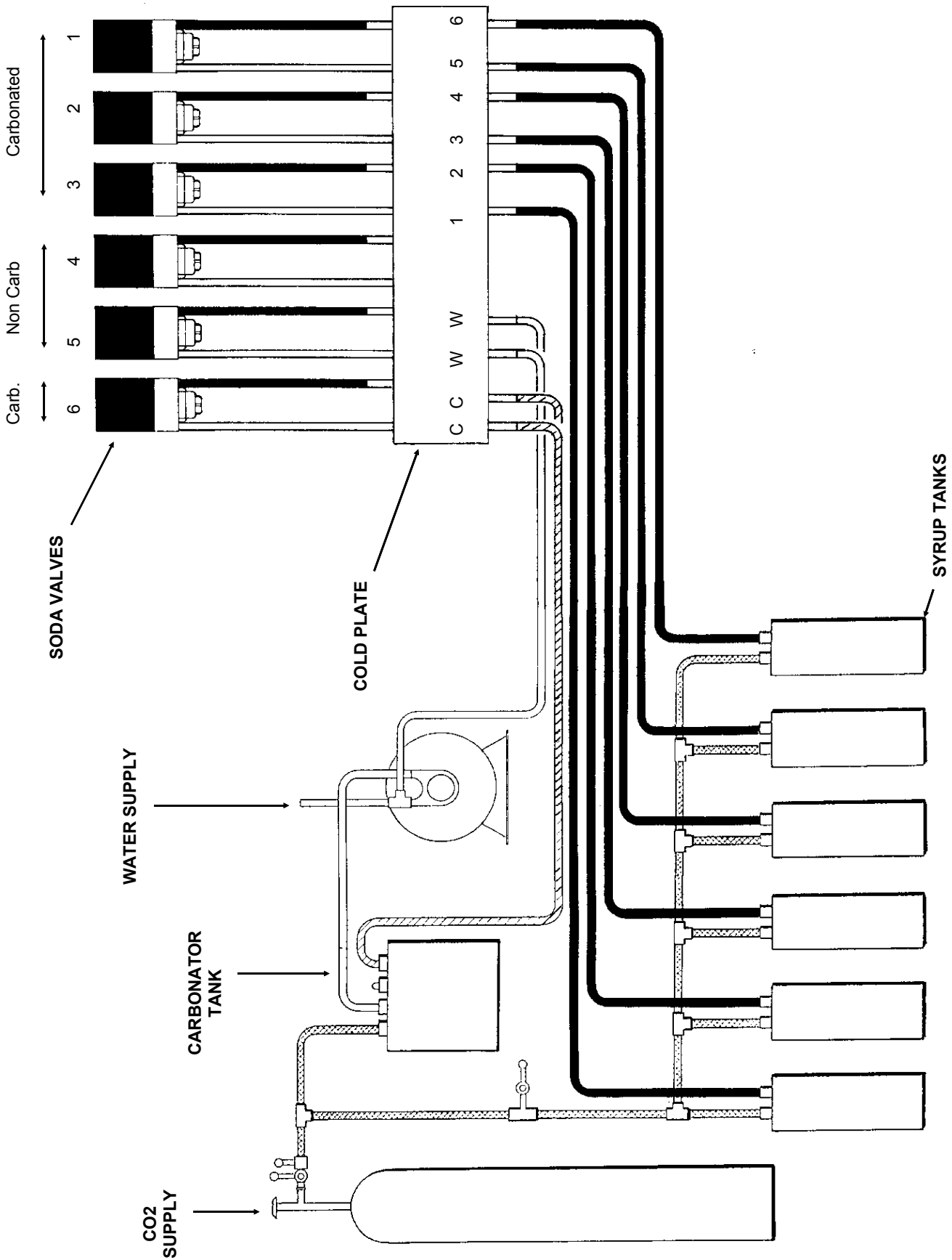

RS160 and RS220

SODA SYSTEM SCHEMATIC: 8 Valve Units

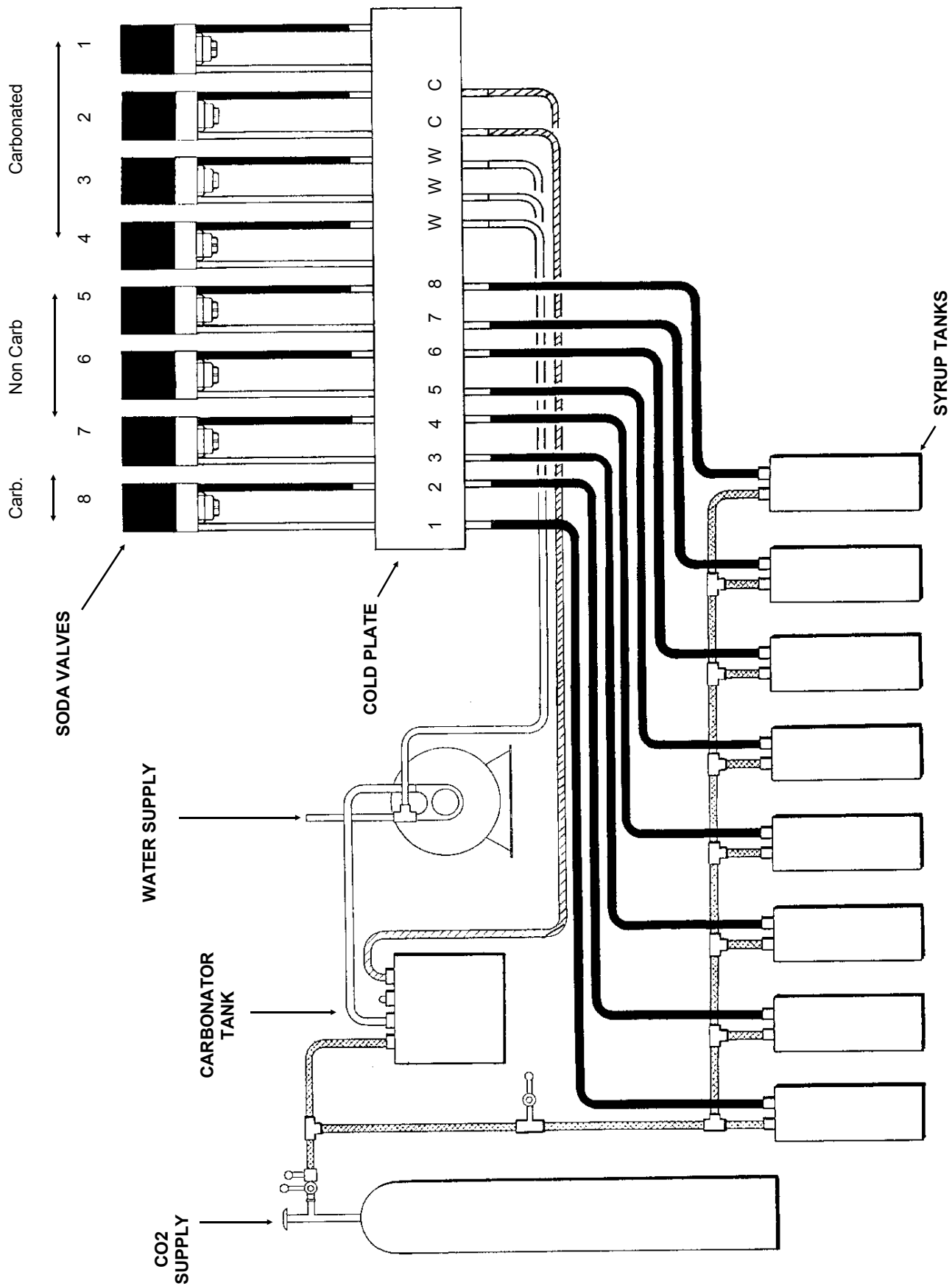

HOW IT WORKS

The ice is stored in a hopper, and the hopper is sloped towards the front of the dispenser. At the front there is an angled rotor, when that rotor turns it scoops ice up, lifts it to the top of the ice chute and drops it through that chute into the user's container.

At the base of the hopper is a cold plate (a block of aluminum with several circuits of stainless steel tubing molded within it). Ice in the hopper is in contact with the cold plate and causes the beverages within the tubing to become chilled.

The ice in direct contact with the cold plate is not dispensed.

Cut Away View

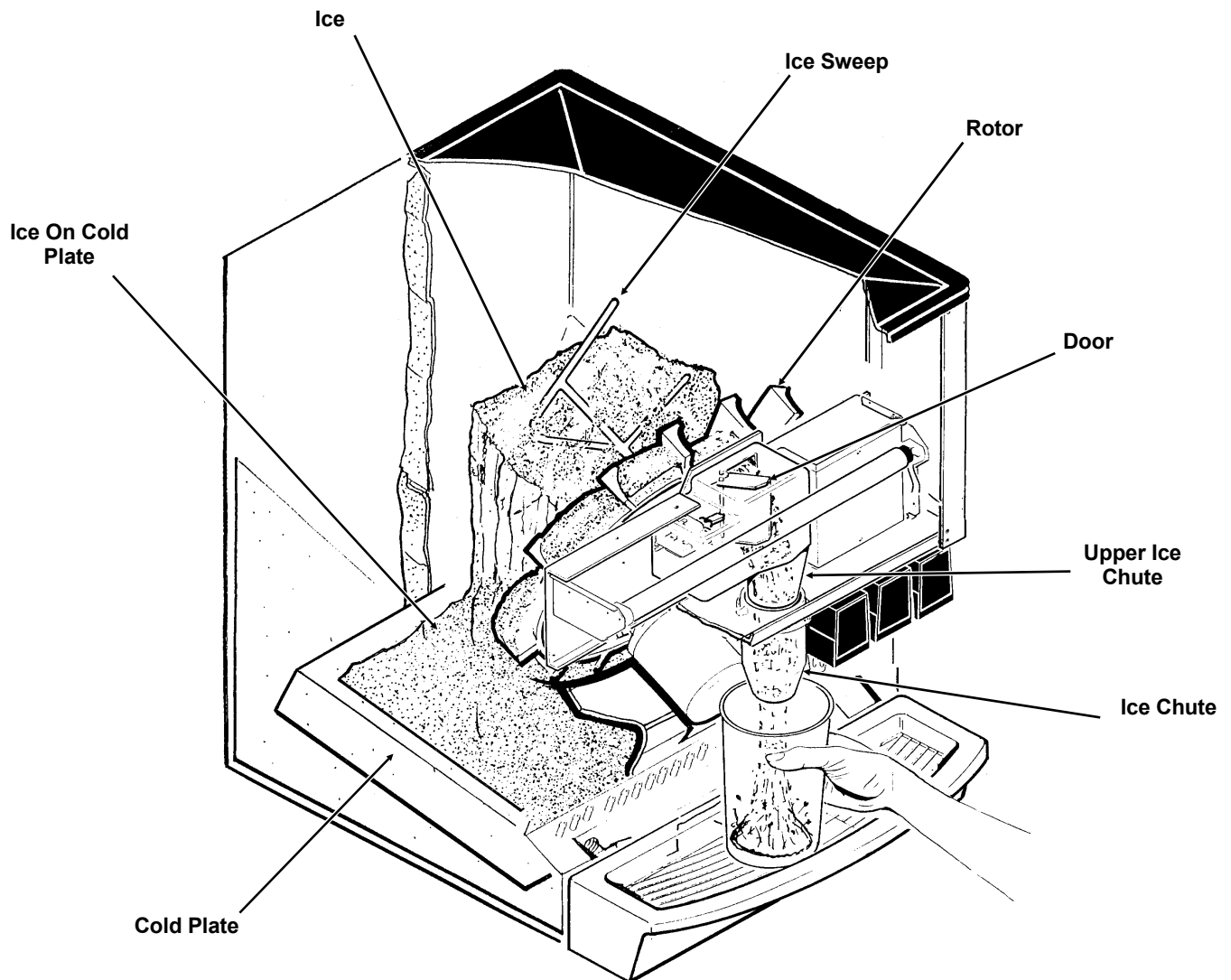

RS160 and RS220

INITIAL START UP

1. Turn on the CO₂.
2. Set the high pressure regulator (to the carbonator) to 80-100 PSI.
3. Set the low pressure regulator to 40-50 psi. Set diet regulator (if used) to 10-15 psi.
4. Turn on the water to the carbonator.
5. Plug in or turn on the carbonator.
6. Purge CO₂ gas pressure from the carbonator tank once or twice while it is filling by pulling up on the pressure relief valve on the top of the tank.
7. Sanitize the ice storage system as instructed on page 16.
8. Turn the key switch to ON.

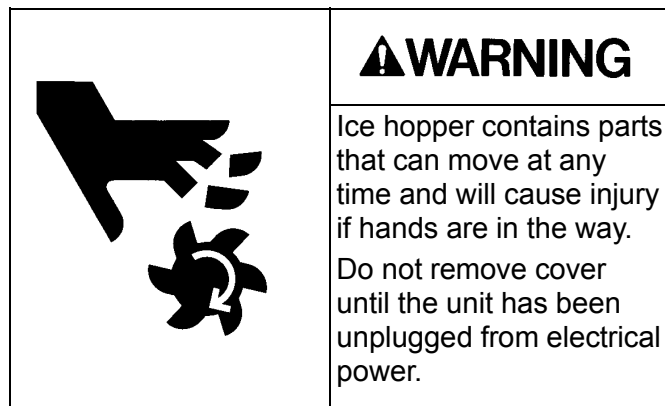

9. Fill hopper with sanitary ice.
10. Plug the unit's power cord into an electrical outlet, the lighted sign should come on. Dispense several containers of ice.
11. Activate soda valves until water is dispensed.
12. Check the primary CO₂ gauge for the carbonator, and the secondary CO₂ gauge for the syrup.
13. Connect the syrup containers to the soda system.
14. Activate the soda valves until syrup is dispensed with the water.

15. Leave the unit alone for about a half hour to cool the cold plate and soda product.
16. While waiting, check all connections for leaks, repair as required.
17. When cold plate has cooled, adjust each soda valve for the proper water to syrup ratio.

To remove valve covers:

- Lift up and pull out to remove upper front panel.
- Twist clear ice chute 1/3 turn counterclockwise and pull down to remove.
- Slide ice chute mounting panel forward to remove from cabinet. Valve covers may now be removed. Reverse to reassemble when valves are adjusted.

Note: there is a timer in the control box that will activate the rotor in the ice bin every two hours. The amount of time that the rotor turns is adjustable between one tenth of a second and 4 seconds. The purpose for the timer is to agitate the ice to keep it from fusing together after long periods in the bin.

To Access Soda Valve Covers

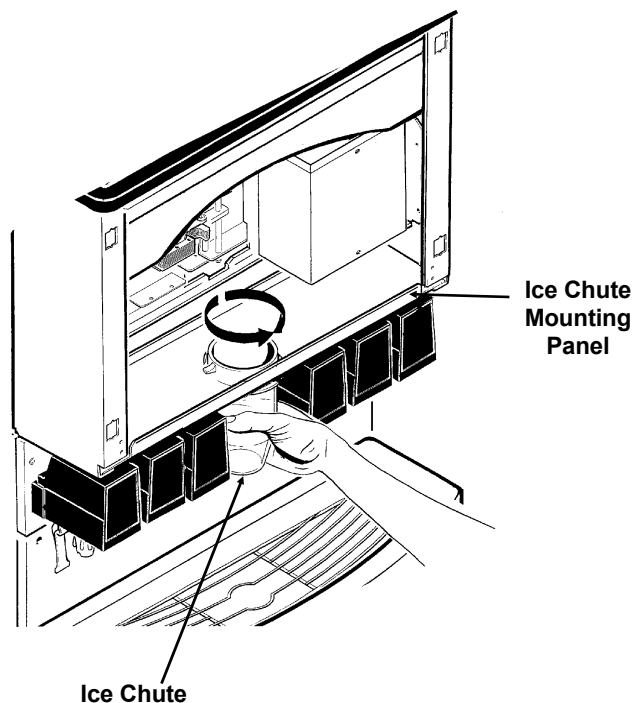

FOR THE OPERATOR

This section covers operating controls, daily pre-operation check, unit operation, adjustments, replenishing CO₂ and syrup supplies, and daily cleaning.

OPERATING CONTROLS - Units have **either** levers **or** push buttons

Levers: Dispensing valve levers, located below the dispensing valves, need only to be pressed with a cup or glass to dispense product.

Ice: Ice will continue to be dispensed for as long as the lever is held in, or until the hopper is empty.

Push Buttons: On the front of each valve will be a button, that when pushed, will activate the valve.

Ice: When the ice dispense button is pushed, ice will be dispensed for as long as the button is held in or until the hopper is empty.

General Information

Dispensing Soda: To minimize foaming, a cup, 1/3 full of ice, should be filled at an angle so that the product runs down the inside wall of the cup, until the cup is nearly full.

When the ice dispense lever or button is pushed, a motor begins to turn the rotor in the hopper, and a solenoid opens the ice chute door. Ice is then dropped down through the ice chute.

NOTE: Periodically during the day, clean up the ice spilled in the drip tray.

There is a timer in the control box that will activate the rotor in the ice bin every two hours.

No ice will fall out because the ice chute door will remain closed. The amount of time that the rotor turns is factory set at 2 seconds, and is adjustable between one tenth of a second and 4 seconds. The reason for the timer is to stir the ice so that it doesn't fuse together after long periods in the bin.

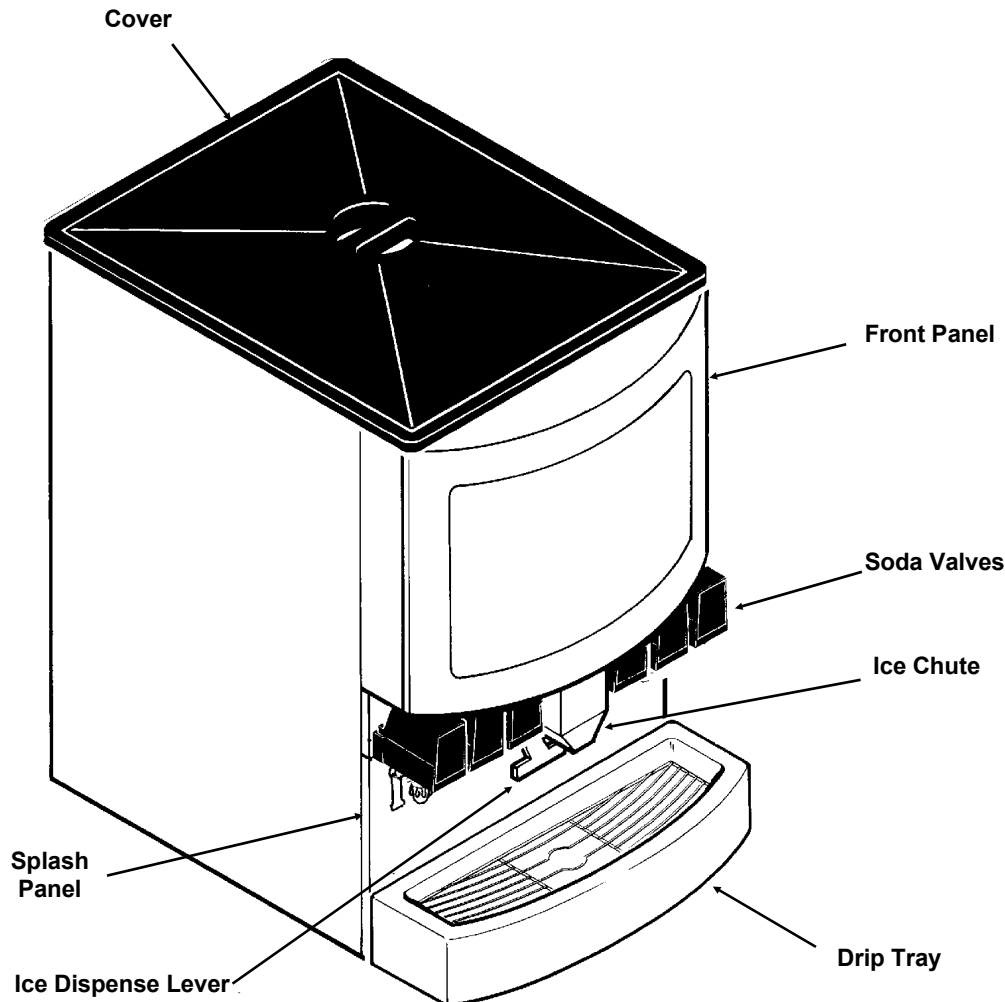

RS160 and RS220 FOR THE OPERATOR

Daily Check

1. Make sure that the CO₂ cylinder primary regulator assembly 1800 psi gauge is not in the shaded ("change CO₂ cylinder") portion of the dial. If so, CO₂ cylinder is almost empty, and must be replaced.
2. Sufficient syrup supply in all syrup containers. If not, replenish syrup supply.
3. Make sure drip tray and grill are clean.
4. Make sure soda valve nozzles are clean.
5. Remove cover and pour sanitary ice into the hopper.

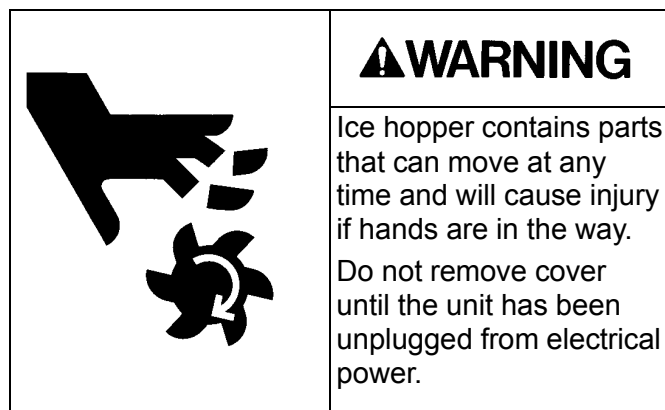

Do NOT use bagged ice directly from a freezer. The ice **must** be broken up in the bags first before adding to the hopper.

Large chunks of ice can NOT be dispensed.

The dispenser must always contain ice to have ice available for use, and to keep the syrup product cool. If there is no ice in the hopper, it will take about 1/2 hour after ice is added for the cold plate to cool off properly.

NOTE: After ice is loaded into a WARM hopper, dispense several containers of ice: this helps disperse the ice across the cold plate.

Keep the cover in place, and check the ice supply regularly during operating hours.

6. Keep drip tray clear of spilled ice

7. At the end of the day:

Remove soda valve nozzles and diffusers, clean them and soak in hot water.

Remove the grill from the drip tray, clean the drip tray, grill and splash panel, make sure the drain is open by pouring hot water into the drip tray. Return the grill to the drip tray.

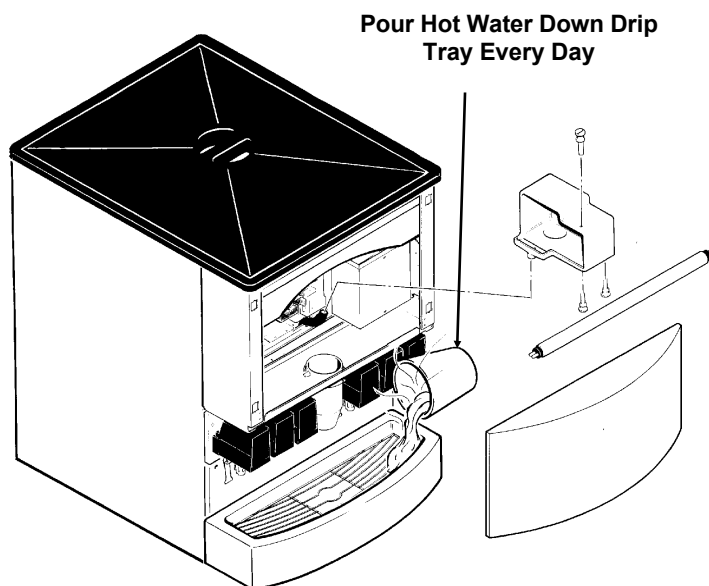

To avoid a delay in cooling soda at the beginning of the business day, make sure that the hopper is kept at least 1/4 full of ice to keep the cold plate (and the soda product) cold overnight.

FOR THE OPERATOR

Replenishing CO₂ Supply

Note: When indicator on CO₂ cylinder regulator 1800 psi gauge is in the shaded area, the cylinder is almost empty and should be changed.

1. Fully close (clockwise) CO₂ cylinder valve.
2. Slowly loosen CO₂ regulator assembly coupling nut allowing CO₂ pressure to escape, then remove regulator assembly from CO₂ cylinder.

3. Unfasten safety chain and remove empty CO₂ cylinder.

<p>If the CO₂ tanks falls over, valve can become damaged or broken off, this can cause serious injury.</p> <p>To avoid personal injury and/or property damage, always secure CO₂ cylinder with a safety chain to prevent it from falling over.</p>	<p>▲WARNING</p>
---	------------------------

4. Position CO₂ cylinder and secure with safety chain.

5. Make sure gasket is in place inside CO₂ regulator coupling nut, then install regulator on CO₂ cylinder.

6. Open (counterclockwise) CO₂ cylinder valve slightly to allow lines to slowly fill with gas, then open valve fully to back seat valve. (Back seating valve prevents leakage around valve shaft.)

7. Check CO₂ connections for leaks. Tighten loose connections.

Replenishing Syrup Supply.

1. Remove CO₂ disconnect and syrup disconnect from empty syrup tank, then remove tank.

2. Place full syrup tank in position, then connect CO₂ disconnect and syrup disconnect to full syrup tank.

Syrup Flavor Change.

Contact beverage supplier to have soda circuit sanitized.

RS160 and RS220

CLEANING AND SANITIZING

The drip tray, grill and splash panel area should be cleaned daily.

The soda valve nozzles and diffusers should be cleaned weekly.

The ice storage system should be sanitized monthly.

Daily:

1. Lift up and remove grill from drip tray.
2. Use mild soap, hot water, and a clean cloth to wash drip tray and splash panel; rinse with hot water, allowing plenty of hot water to run down the drain.
3. Wash the grill, then rinse with clean water. Place back in drip tray.
4. Clean all exterior surfaces of the unit with warm water and a sponge. Rinse out the sponge with clean water, wring excess water out of the sponge, and wipe off external surfaces of the unit. Wipe unit with a clean soft cloth. Do NOT use abrasive type cleaners.

Weekly:

Clean valve nozzles & diffusers:

Looking down from the top of the unit, turn the nozzle clockwise about 1/8 turn; pull down to remove it.

Pull down to remove the diffuser.

Clean both with soap and water, rinse with potable hot water. Replace on the valve.

BOOTH VALVE

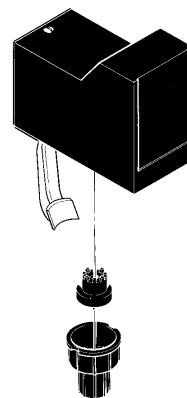

CORNELIUS VALVE

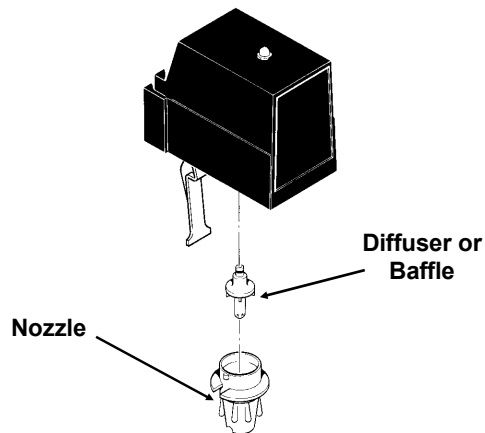

DOLE VALVE

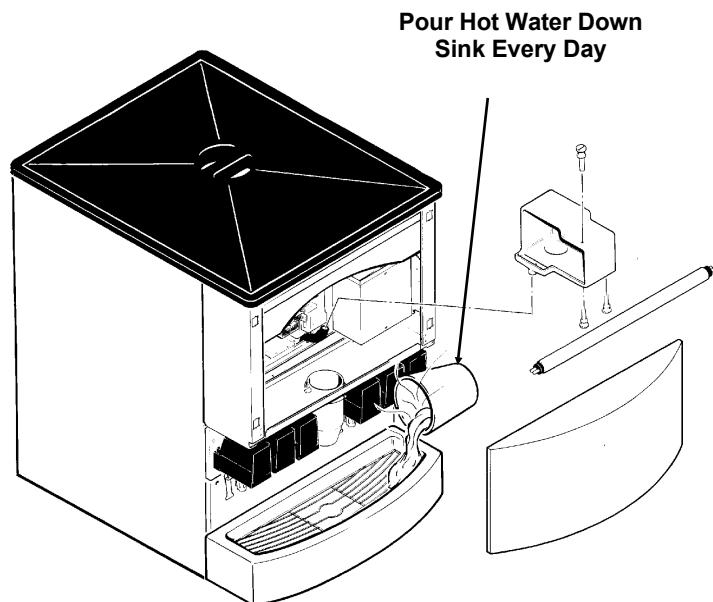
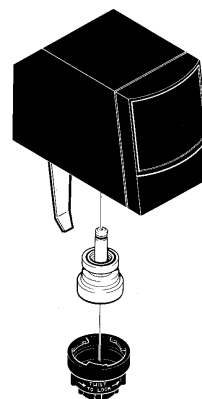

CLEANING AND SANITIZING

Monthly/Initial Start Up:

Sanitize the Ice Storage System.

Note: this should only be done by qualified personnel.

1. Unplug the Refreshment Stand's electrical cord from the electrical power.

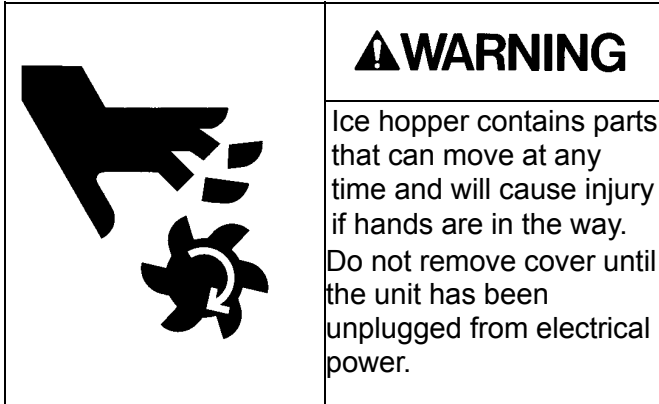

2. Remove cover and discard all remaining ice

3. Mix a solution of 1 ounce of household bleach to 2 gallons of potable water, or: mix a solution of any approved sanitizer, following the directions for mixing and applying that sanitizer.

4. Unscrew the sweep arm from rotor shaft, and pull the rotor from hopper.

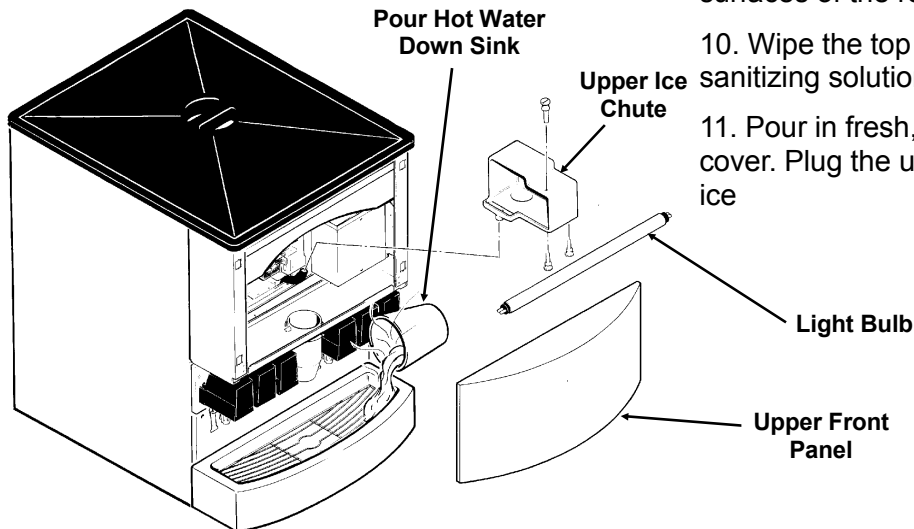
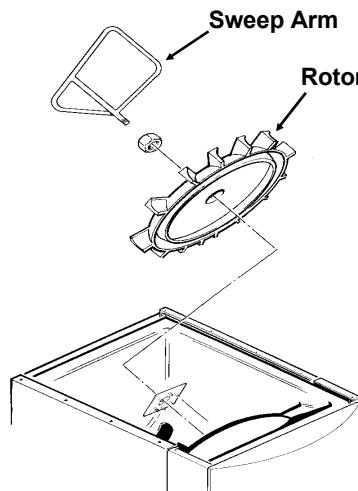

5. Using a clean cloth or sponge, wipe all interior surfaces of the ice storage hopper with the sanitizing solution, allow to air dry.

6. Wipe all surfaces of the rotor with the sanitizing solution, and allow to air dry.

7. Pull out and remove the upper front panel.

A. Twist the clear ice chute 1/3 turn, and pull down to remove.

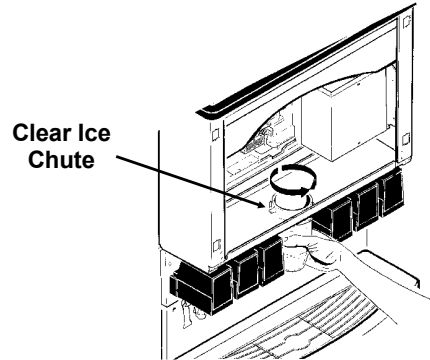

B. Locate the two thumb screws holding the upper ice chute; remove them (1 on top and 1 below). Remove the upper ice chute from the machine.

Thoroughly wipe the surfaces of the bin door and both ice chutes with the sanitizing solution, and allow to air dry.

Place the upper ice chute back onto the dispenser, secure with the two thumb screws.

Place the clear ice chute back onto dispenser. Place the upper front panel back onto the machine.

8. Wipe the inside surface of the cover with the sanitizing solution, and allow to air dry.

9. Reassemble the rotor and hopper, re-wipe the surfaces of the rotor and allow to air dry.

10. Wipe the top edge of the ice hopper with the sanitizing solution, allow to air dry.

11. Pour in fresh, sanitary ice and replace the cover. Plug the unit in, it is now ready to dispense ice

RS160 and RS220

SANITIZING SYRUP SYSTEM

To Be Performed By Qualified Personnel Only

The procedure below is for the sanitation of one syrup circuit at a time. Repeat to sanitize additional circuits. These instructions are for a stainless steel product tank system.

Note: When cleaning a bag-in-box beverage system disconnect the coupling from the bag and connect to a coupling cut from an empty bag.

Place the coupling into a stainless steel product tank and use the procedures below but do not pressurize the tank.

Materials Required:

- Sanitizing agent such as "Chlor-tergent" (Oakite products Co.).
- Three empty, clean syrup tanks (5 -10 gallon)
- An open container (1 - 5 gallon)
- Plastic brush or soft cloth

1. Rinse tank - fill with cold (room temperature) tap water.

2. Prepare sanitizing tank #1. Prepare the solution by dissolving the required amount of concentrate to supply 200 PPM (parts per million) available chlorine in enough water to flush and sanitize the number of circuits to be sanitized, usually about 1 gallon per circuit. Water temperature should be between 125⁰F. and 145⁰F.

3. Prepare sanitizing tank #2. Prepare a solution by dissolving the required amount of concentrate to supply 100 PPM (parts per million) available chlorine for about 1 gallon of solution. Water temperature should be between 125⁰F. and 145⁰F.

4. Prepare a sanitizing container. Prepare a solution by dissolving the required amount of concentrate to supply 100 PPM (parts per million) available chlorine for about 1 gallon of solution. Water temperature should be between 125⁰F. and 145⁰F.

5. Disconnect all lines from product tanks.

6. Connect CO₂ cylinder with regulator set at 45 - 50 psi to each tank as needed in steps 8 - 11.

7. Connect sanitizing tank #1 (200 PPM) to product lines. Actuate each valve to flush sanitizing

solution through the system for 2 minutes. Allow the solution to remain in the system for a minimum of 5 minutes.

8. Connect rinse tank to product lines and open dispensing valves to flush sanitizing solution from the system.

9. Remove the dispensing valves and quick connect sockets. Remove nozzle and diffuser of valves, if applicable. Clean all surfaces with 100 PPM sanitizing solution and cloth, if necessary.

10. Place removed valve parts and quick disconnect sockets in the sanitizing solution (110 PPM) for fifteen minutes.

11. Reassemble valves and install on dispenser. Reconnect quick connect sockets.

12. Connect sanitizing tank #2 (100 PPM) to product lines and draw sanitizing solution through

To avoid personal injury or property damage, do not remove cover from the pressurized tank until all pressure has been released from the tank.	▲WARNING
--	-----------------

each valve for two minutes. Allow sanitizing solution to remain in the system for a minimum of twenty (20) minutes. Disconnect sanitizing tank.

13. Reconnect all lines.

14. Connect a tank containing clean, uncontaminated product to product lines. Draw product through the lines until all sanitizing solution has been removed from the system.

Flush sanitizing solution from syrup system.	▲WARNING
---	-----------------

Residual sanitizing solution left in the system could create a health hazard.

SERVICE DIAGNOSIS

PROBLEM	PROBABLE CAUSE	CORRECTION
Dispensed product produces foam as it leaves dispensing valve.	1. No ice on Hopper.	1. Replenish ice supply, allow ice to contact Hopper for 1/2 hour to cool product.
	2. Carbonator CO ₂ regulator pressure too high for existing water conditions or temperature.	2. Reduce carbonator CO ₂ regulator pressure setting.
	3. Syrup over carbonated with CO ₂ as indicated by bubbles in inlet syrup lines leading to the unit.	3. Remove syrup tank's quick disconnects. Relieve tank CO ₂ pressure, shake tank vigorously, then relieve tank CO ₂ pressure as many times as necessary to remove over carbonation.
	4. Dispensing valve restricted or dirty.	4. Sanitize syrup system as instructed.
	5. Dirty water supply.	5. Check water filter. Replace cartridge. NOTE: If the water supply is dirty, be sure to flush lines & carbonator completely. If needed, remove lines to carbonator tank, invert tank and flush tank and all inlet lines to remove any foreign particles or dirt.
Only carbonated water dispensed.	1. Quick disconnects not secure on syrup tanks.	1. Secure quick disconnects on syrup tanks.
	2. Out of syrup.	2. Replenish syrup supply as instructed.
	3. Syrup tank's secondary CO ₂ regulator not properly adjusted.	3. Adjust syrup tanks secondary CO ₂ regulator.
	4. Inoperable dispensing valve.	4. Repair or replace dispensing valve.
	5. Dispensing valve syrup flow regulator not properly adjusted.	5. Adjust dispensing valve.
	6. Dispensing valve, syrup tank disconnects, or syrup lines restricted.	6. Sanitize syrup system.
Only syrup dispensed.	1. Plain water inlet supply line shut off valve closed.	1. Open plain water inlet supply line valve.
	2. Carbonator power cord unplugged.	2. Plug carbonator in.
	3. Carbonator primary CO ₂ regulator not properly adjusted.	3. Adjust carbonator primary CO ₂ regulator.

RS160 and RS220

SERVICE DIAGNOSIS

PROBLEM	PROBABLE CAUSE	CORRECTION
Will not dispense ice	1. No ice in hopper	1. Fill hopper with ice
	2. Vend switch does not close	2. Check vend switch, replace if open
	3. Drive motor will not run	3. Check drive motor, and wiring connection, replace if not working
	4. Door solenoid will not open door	4. Check/replace door and solenoid
	5. Rotor will not turn	5. Check hub of rotor
	6. Relay for vend switch does not close during operation.	6. Check relays, replace if necessary.
Water to syrup ratio too low or too high	1. Dispensing valve syrup flow regulator not properly adjusted	1. Adjust water to syrup ratio
	2. CO ₂ gas pressure to syrup tanks insufficient to propel syrup out of the tank	2. Adjust syrup tanks secondary CO ₂ regulator
Adjustment of dispensing valve syrup flow regulator does not increase to desired water to syrup ratio	1. No syrup supply	1. Replenish syrup supply as needed.
	2. Syrup tank quick disconnects not secure	2. Secure quick disconnects
	3. Syrup tanks secondary CO ₂ regulator out of adjustment.	3. Adjust syrup tanks secondary CO ₂ regulator
	4. Dispensing valve syrup tank quick disconnect, or syrup line restricted.	4. Sanitize syrup system as instructed
Dispensed product carbonation too low	1. Carbonator primary CO ₂ regulator out of adjustment for existing water conditions or temperature	1. Adjust carbonator primary CO ₂ regulator
	2. Air in carbonator tank	2. Vent air out of carbonator tank through relief valve. Actuate dispensing valve until carbonator comes on.
	3. Water, oil, or dirt in CO ₂ supply	3. Remove contaminated CO ₂ . Clean CO ₂ system (lines, regulators, etc.) using a mild detergent. Install a clean CO ₂ supply.
No product (only water) dispensing from all valves	1. Out of CO ₂	1. Check CO ₂ supply
Dispensed product comes out of the dispensing valve clear, but foams in the cup or glass	1. Oil film or soap scum in cup or glass	1. Use clean cups or glasses

ELECTRICAL SEQUENCE

Refer to the wiring diagram.

Ice Vending:

Ice is dispensed as long as the ice vend lever or push button is pushed, or until the hopper is empty of ice.

- When the ice vend lever or push button is pushed, the vend switch closes, and makes a circuit to the coil of relay A.
- When relay A is energized, relay A's contacts 6-9 and 7-4 close. Relay A's contacts 7-1 open.
- When relay A's contacts 6-9 close, they make a circuit to the door solenoid, which opens the ice door.
- When relay A's contacts 7-4 close, they make a circuit to the coil of relay B.
- When relay A's contacts 7-1 open, the circuit to the timer is opened.
- When relay B's coil is energized, it closes a circuit to the gearmotor, and the motor turns the rotor.

Stand By:

- Relay A's contacts 7-1 are closed and make a circuit to the timer.
- The timer is energized when the unit is not dispensing. The timer switch will close for a few seconds every two hours.
- When the timer switch is closed, it makes a circuit to relay B's coil.
- When relay B is energized, it powers the gearmotor, and the rotor is turned.

Soda Dispensing

Soda beverages are dispensed as long as the valve levers or push buttons are held in, and there is CO₂ and syrup.

- The key switch is closed, the circuit to all of the valves is enabled.
- When a valve lever or push button is pushed in, the valve switch will close, making a circuit to the coils of the valve which opens it.

RS160 and RS220

MOVING

If the dispenser is going to be moved to another building, shipped any distance, or if there is any possibility that it may be exposed to freezing temperatures, it must be thoroughly cleaned of all liquids to prevent damage.

⚠ CAUTION

1. Sanitize syrup system as instructed on page 15.
2. Shut off water supply.
3. Unplug carbonator.

4. Remove connectors from syrup tanks.
5. Connect an empty syrup tank to one circuit.
6. Actuate valve on that circuit until only CO₂ (gas) flows from it.
7. Repeat steps 5-6 for all valves.
8. Remove all ice
9. Drain all water from bin and drain circuit.
10. Remove all field connections from cold plate.

REMOVAL & REPLACEMENT

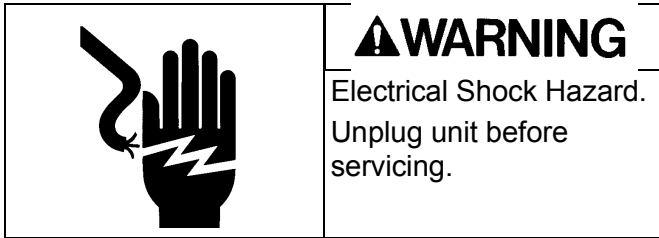

To Replace Vend Switch:

1. Disconnect Electrical Power.
2. Lift up and pull out and remove upper front panel.

Lever Type Actuation:

- A. Twist ice chute 1/3 turn and pull down to remove.
- B. Remove screws holding valve mounting plate to cabinet. Pull valve and plate assembly out and away from cabinet. Switch is mounted to valve plate.

Reverse steps to reassemble.

Push Button Actuation:

Locate vend switch behind push button assembly of upper front panel.

3. Remove wires from switch.
4. Remove screw and nut retaining switch to mounting plate, and remove switch from dispenser.
5. Reverse steps to reassemble.

To Replace Gear Motor Assembly:

1. Disconnect electrical power.
2. Remove cover from hopper.
3. Unscrew sweep arm holding rotor to gearmotor shaft.

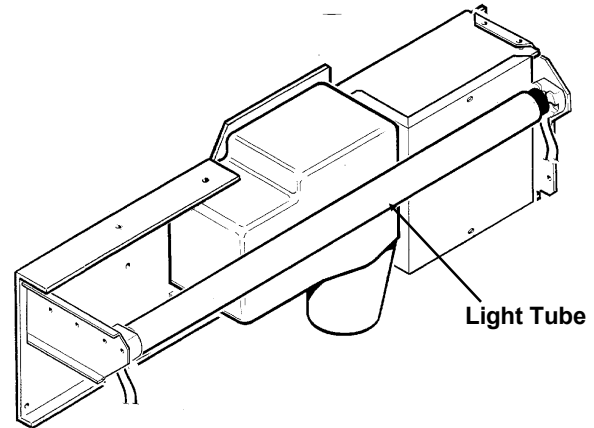

4. Remove rotor from gearmotor shaft.
5. Remove splash panel.
6. Remove upper panel.
7. Twist ice chute 1/3 turn and pull down to remove.
8. Remove ice chute mounting plate.
9. Remove screws holding valve mounting plate to cabinet. Pull valve assembly out and away from cabinet.
10. Mark location of gearmotor bracket on cross-brace.
11. Disconnect gearmotor electrical leads in control box
12. Remove (4) screws holding gearmotor bracket to cross brace.
13. Pull gearmotor & bracket from cabinet.
14. Remove bracket from gearmotor.
15. Reverse to reassemble. Gearmotor bracket should be installed where it was, so that the rotor should clear bin surface by 1/8" to 1/4". If needed, the slots on the gearmotor bracket will allow the position of the rotor to be adjusted.

RS160 and RS220

REMOVAL & REPLACEMENT

To Replace Solenoid:

1. Disconnect electrical power.

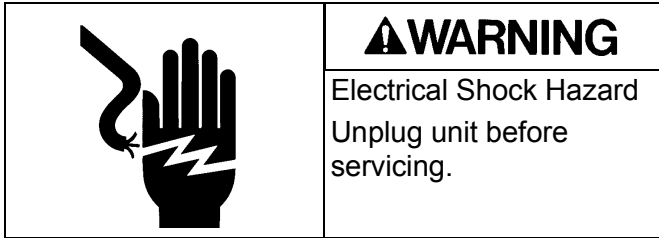

2. Lift up and pull out and remove upper front panel. Remove fluorescent tube
3. Remove 2 thumb screws holding lower brace and remove.
4. Remove 3 thumb screws holding upper ice chute cover, and remove cover. Remove the metal solenoid cover.

5. Disconnect electrical leads from solenoid.
6. Straighten cotter pin, and remove pin from solenoid plunger.
7. Remove rubber mounting screws holding solenoid to cabinet, and remove solenoid from cabinet.
8. Reverse to reassemble.

To Replace Light:

1. Disconnect electrical power.
2. Pull out and remove upper front panel.
3. Twist fluorescent tube out of sockets.
4. Reverse to reassemble.