

**Scotsman®**

Installation and  
User's Manual for  
Residential Ice Machine

Models SCCG30 and SCCP30



# SCCG30 & SCCP30

## User Manual

### Introduction:

---

This ice machine is the result of Scotsman's decades of experience in the design and manufacturing of both commercial and residential ice machines.

This manual includes the information needed to install, start up and maintain the ice machine. Note any Caution or Warning indicators, as they provide notice of potential hazards. Keep this manual for future reference.

### Table of Contents

Specifications . . . . .	Page 3
Cabinet Layout . . . . .	Page 4
Air flow . . . . .	Page 5
Water Quality: . . . . .	Page 6
Door Panel . . . . .	Page 7
Door Panel Attachment . . . . .	Page 8
Door swing change . . . . .	Page 9
Water . . . . .	Page 10
Gravity Drain . . . . .	Page 11
Electrical . . . . .	Page 12
Use . . . . .	Page 13
How to clean the condenser. . . . .	Page 14

# SCCG30 & SCCP30

## User Manual

### Specifications

---

This ice machine is designed to be used indoors, in a controlled environment. Use outside of the listed limitations is misuse and will void the warranty.

#### Air temperature limits

The ice machine will operate adequately within the limits, but functions best in temperatures between 70 and 80 degrees F.

- Minimum – 50 degrees F
- Maximum – 100 degrees F

#### Water temperature limits

- Minimum – 40 degrees F.
- Maximum – 100 degrees F.

#### Water pressure limits

- Minimum – 20 psi
- Maximum – 80 psi

Because the ice machine is making a food product, the water supply to the ice machine must be potable, or fit for human consumption.

#### Electrical Voltage

- Minimum - 104 volts
- Maximum – 126 volts

#### **Options:**

Door Panel kits: Finished door panels are available from Scotsman for attachment to the machine, or a custom panel can be made.

Kit Number	Panel Finish	Handle Finish
KDFS	Stainless Steel	Stainless Steel

Kickplate Extension: In some situations the leg levelers will be extended enough to become visible. A kit to extend the kickplate over the legs is **KKPF**.

Cabinet Stability: In some free standing installations it may be prudent to add a bracket that secures the back of the cabinet to a wall. That kit number is **KATB**.

Drain Conversion: A gravity drain model can be converted to a drain pump model by installing a drain pump kit. The drain pump kit consists of a drain pump, wiring harness and associated tubing. The part number is A39462-021.

#### **Warranty Information**

Warranty information is supplied separately from this manual. Refer to it for coverage. In general, the warranty covers defects in materials or workmanship and does not cover corrections of installation errors or maintenance.

### **Models**

- SCCP30M-1SU – Pump model, stainless cabinet
- SCCG30M-1SU – Gravity drain model, stainless cabinet

### **Cabinet Dimensions**

Width	Depth, w/out door panel	Depth, with door panel, handle adds 1 5/8"	Height
14 7/8"	22"	22 3/4"	33 3/8" to 34 3/8"

# SCCG30 & SCCP30

## User Manual

### Cabinet Layout

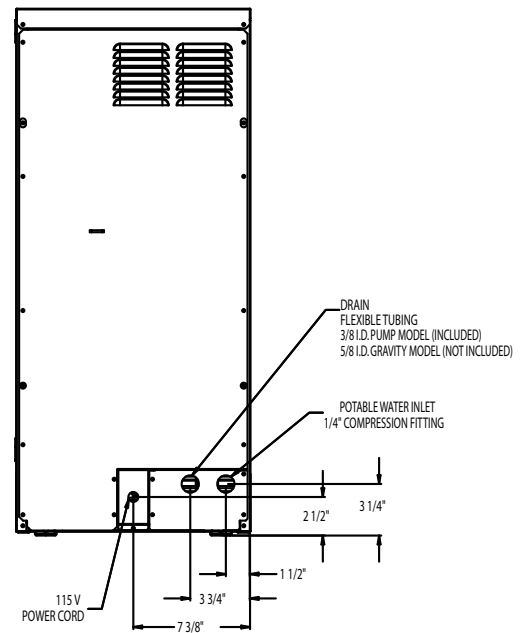
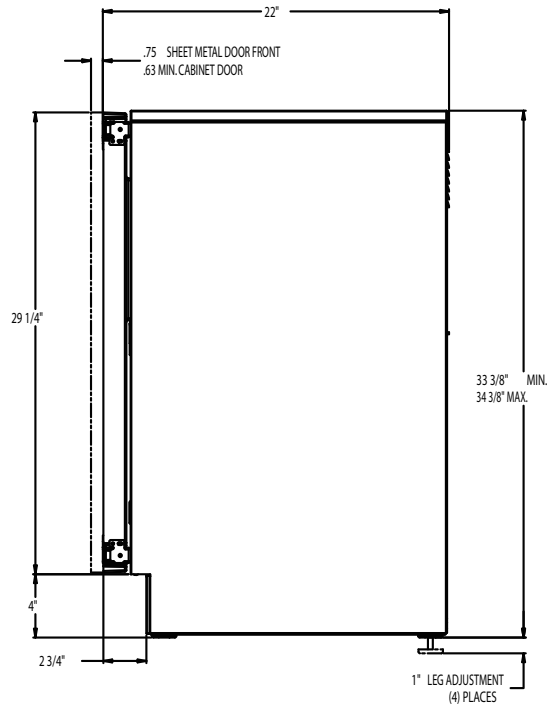
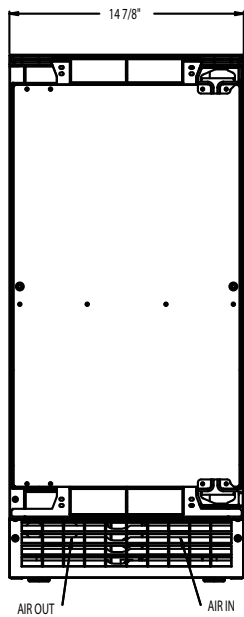
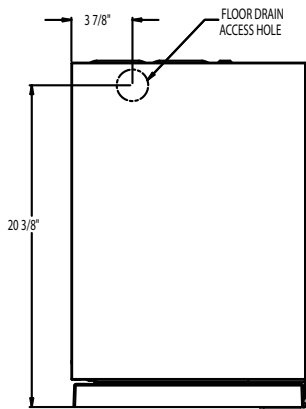

# SCCG30 & SCCP30

## User Manual

### Air flow

---

The machine takes in room temperature air at the lower right front and discharges warm air from the lower left front. Restricting the airflow will adversely affect the ability of the ice machine to make ice.



Scotsman Ice Systems are designed and manufactured with the highest regard for safety and performance. They meet or exceed the standards of agencies like U.L.

Scotsman assumes no liability or responsibility of any kind for products manufactured by Scotsman that have been altered in any way, including the use of any parts and/or other components not specifically approved by Scotsman.

Scotsman reserves the right to make design changes and/or improvements at any time.

Specifications and designs are subject to change without notice.

## SCCG30 & SCCP30

### User Manual

#### Water Quality:

---

All water, including potable water supplied by municipalities, contains some impurities or minerals. Water absorbs impurities from the air as rain and/or as it flows through the ground. Some of the impurities are solid particles, these are known as suspended solids, and a fine particle filter will remove them. Other impurities are chemically bonded to the water molecules, and cannot be filtered out, these are called dissolved solids.

Ice made by this machine will have a lower mineral content than the water it was made from. This is due to the method of making ice. Purer water will freeze first in the ice making molds. The reason for this is that anything dissolved in water lowers the water's freezing temperature. This concentrates most of the impurities in the ice machine water reservoir where they may form hard deposits known as scale. The machine dilutes the concentration of minerals by over-filling the reservoir during the harvest cycle (with the excess water flowing down the drain). About 3 quarts of water flow into the unit each cycle. About 1 quart of that rinses the reservoir and goes down the drain.

Some impurities will inevitably remain, and will stick to the parts in the machine, and will cause malformed ice cubes. Eventually, **built up mineral scale can shorten machine life.**

To keep the machine operating properly, these impurities or minerals will have to be regularly dissolved by an acid cleaning, using Scotsman Ice Scale Remover. Directions for this may be found in the section under cleaning.

#### Filters and Treatment

In general, it is always a good idea to filter the water. A water filter, if it is of the proper type, can remove taste and odors as well as particles. Some methods of water treatment for dissolved solids include reverse osmosis, and polyphosphate feeders. A reverse osmosis system should include post treatment to satisfy the R.O. water's potential aggressiveness. Deionized water is not recommended.

Because water softeners exchange one mineral for another, softened water may not improve water conditions when used with ice machines. Where

water is very hard, softened water could result in white, mushy cubes that stick together.

If in doubt about the water, contact a local point of use water specialist for recommendations on water treatment.

#### Installation Overview

The ice machine must be connected to cold, potable water; it must have a drain; it must be connected to the proper power supply and must be able to circulate air through the vents at the front.

# SCCG30 & SCCP30

## User Manual

### Door Panel

---

The ice machine is supplied without a conventional door covering so it can be decorated to the user's preference. Scotsman offers several coverings including white, black and stainless steel. In addition, a custom built panel can be placed onto the door.

#### Door Panel Attachment

To attach a Scotsman supplied panel:

---

Note: If door swing is to be changed, it must be done before panel is attached.

---

The panel will be held on by 6 sheet metal screws and 2 machine screws.

1. Remove the gasket and retain for later use.
2. If the door panel is stainless steel, remove any plastic covering the stainless steel panel.
3. Place the panel onto the outside of the door, and secure it to the door using two machine screws, located at the left center and right center.
4. Fasten the panel to the door using the 6 sheet metal screws. In the hinge area, use the outermost screw holes.
5. Place the covers over the hinge areas, and secure each cover to the door using a sheet metal screw.
6. Insert hole plug over screw installed in step 5.
7. Return the gasket to its original position.

#### Custom Panel

A custom panel of wood or other material not exceeding 15 lb can be attached to the door. Attachment is from the ice side of the door. Holes are provided in the door for this purpose.

See instructions in information packet to create and attach a custom panel:



Door Panel Attachment

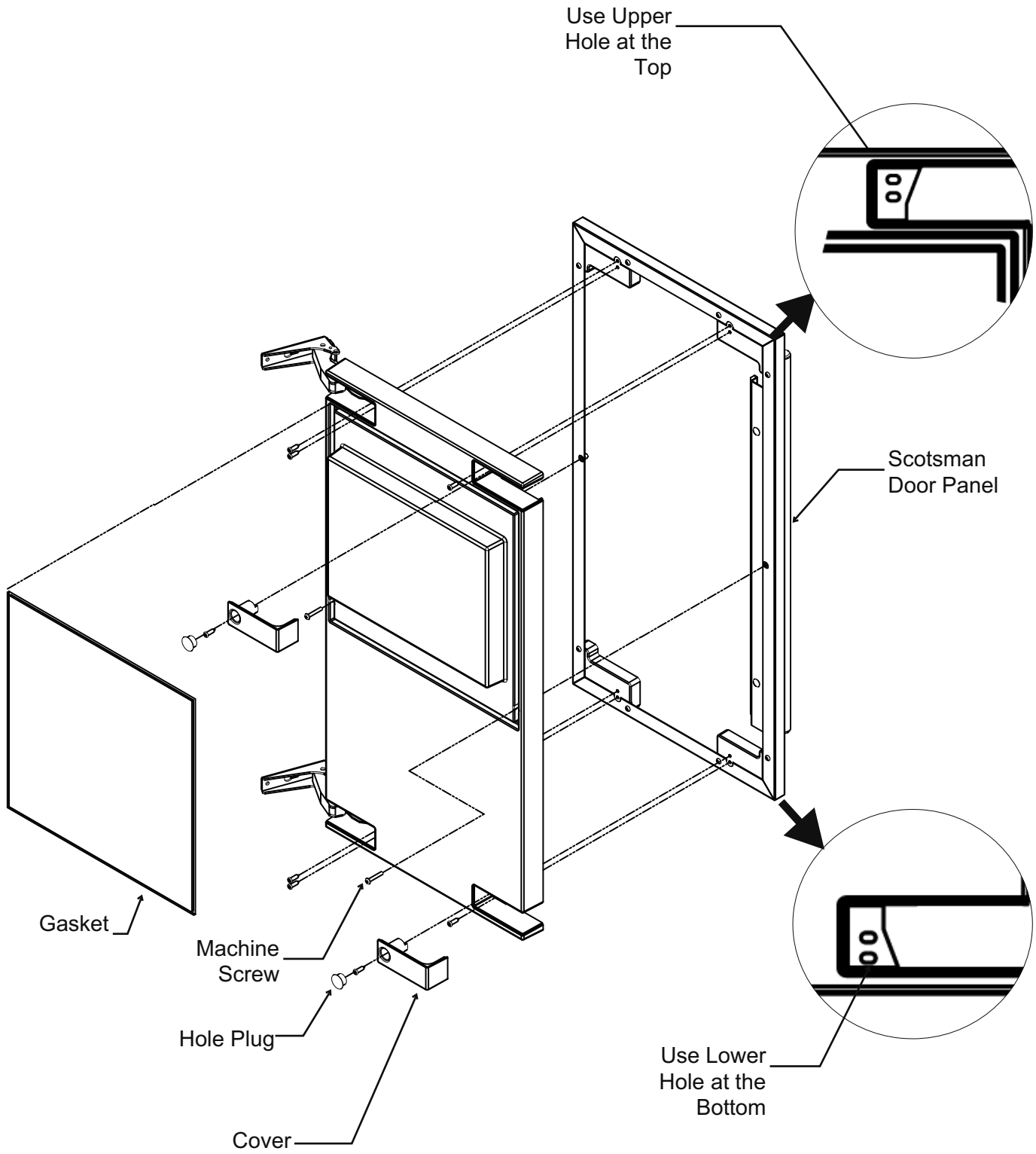



**Door swing change**

The door can be attached to open with hinges on the left or right using new hinge brackets shipped loose in the ice bin. Retain all screws for re-use.

To change:

1. Remove innermost screw holding each hinge to cabinet, loosen the other.
2. Slide hinges to the side and remove door from cabinet. Remove screws loosened in step 1 from both cross braces.
3. Remove two screws securing top panel to back, pull top panel back and remove from cabinet.
4. Remove two screws at the top and lift the upper bracket out of the cabinet. Replace with the one supplied loose with the machine. Fasten it to the cabinet using the original screws.
5. Return the top panel to the cabinet and fasten it with the original screws.
6. Remove kickplate and front service panel.
7. Remove two front screws and two bottom screws holding the bottom door bracket to the cabinet.

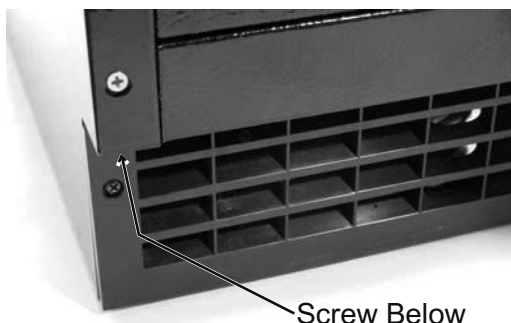
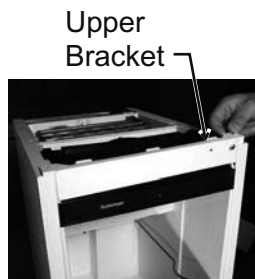

8. Replace the bracket with the one supplied loose with the machine. Secure it using the original screws.
  9. Remove the upper hinge and move it to the door's opposite side, bottom location. Secure using the original screws.
- 
- Note: If door panel is attached, it must be removed to access hinge screws.
- 
10. Remove the original lower hinge and move it to the door's opposite side, upper location. Secure using the original screws.
  11. Install a screw removed in step 2 in outermost hole of upper and lower cross braces.
  12. Attach the door to the cabinet using the original screws.
  13. Return kickplate and front service panel to their original positions and attach to the cabinet using the original screws.

**Installation Notes**

*Built In Situations:* If a finished floor is to be installed in the area after the ice machine has been built in, shims the expected thickness of the floor should be installed under the unit to keep the machine level with the planned floor level.

*Installations on a slab:* Use a pump model and pump the water to the point of drainage. Pump models will pump 1 story (10 feet) high.

*Installations over a crawl space or basement:* Either gravity drain or pump model units may be used, if there is not enough room behind the machine for a drain/waste receptacle, the drain will have to be below the floor.

---

Note: When installed in a corner, the door swing may be limited due to handle contact with the wall or cabinet face.

---

# SCCG30 & SCCP30

## User Manual

### Water

The recommended water supply tubing is ¼ inch OD copper. Stainless steel flex or reinforced PVC tube may also be used. Install an easily accessible shut-off valve between the supply and the unit. This shut-off valve should not be installed behind the unit.

---

Note: Do not use self-piercing type valves.

---

1. Remove the front service panel.



2. Route the tubing through the right hole in the back to the inlet water solenoid valve inlet.

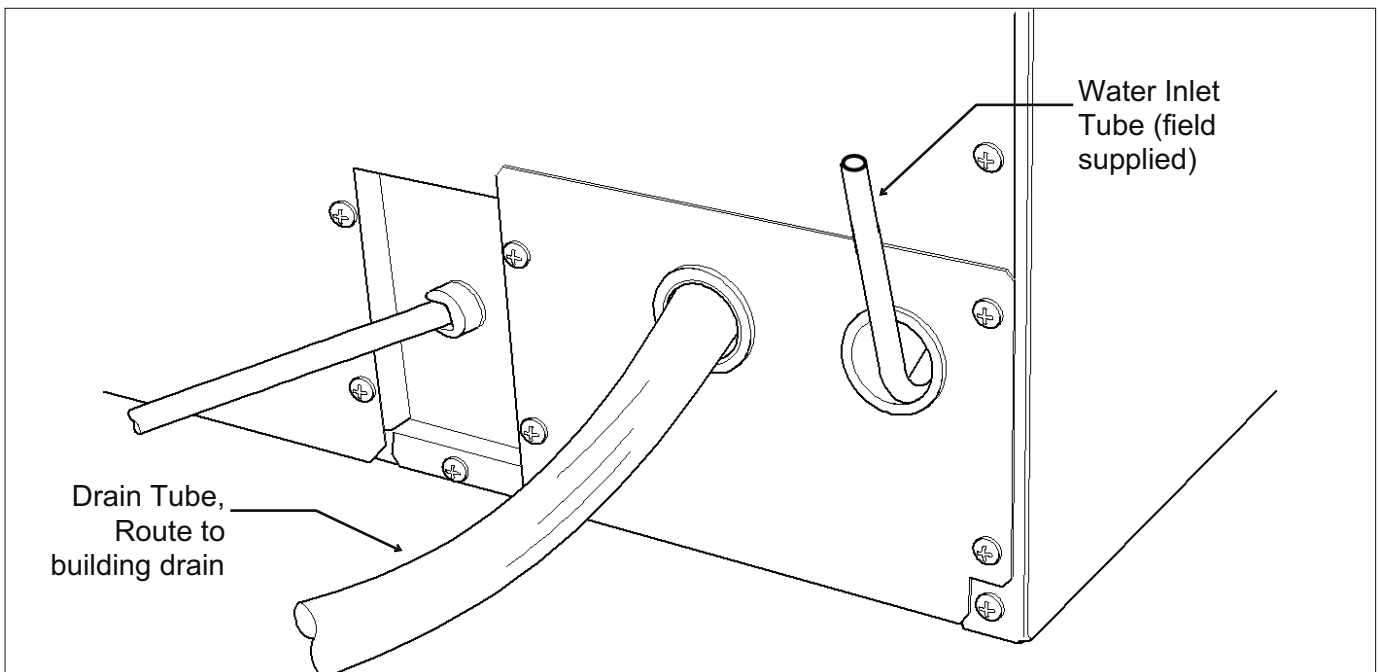

Back View, Drain Pump Model

3. Install a compression fitting on the tubing and connect to the inlet of the solenoid.

### Drains

There are two types of ice machine models, one that drains by gravity and one that has an internal drain pump.

#### Drain Pump Model drain installation

1. Locate the coil of 3/8" ID plastic drain tubing secured to the back of the unit.
2. Route the plastic drain tube from the back of the unit to the drain connection point.

---

**IMPORTANT NOTE:** Often an air gap is required by local codes between the ice maker drain tube and the drain receptacle.

---

# SCCG30 & SCCP30

## User Manual

### Gravity Drain

Caution: Restrictions in the drain system to the machine will cause water to back up into the ice storage bin and melt the ice. Gravity drain tubing must be vented, have no kinks and slope to the building drain. Air gaps are typically required by local code.

1. Place the ice machine in front of the installation opening. Adjust leveling legs to the approximate height.

2. Remove the front service access panel and the upper back panel.

---

Note: If you are connecting a gravity drain model and the drain opening has been located in the floor under the base pan according to the pre install specifications, follow steps 3 through 5 to drain the unit through the base. If not, proceed to step 6b.

---

3. Remove the clamp and barbed elbow and take off the plastic cover in the base pan below the drain hose.

4. Connect a straight 5/8" barbed connector to the drain hose, securing with the clamp removed in step 4.

5. Cut an 8" piece of 5/8" ID X 7/8" OD tygon (clear plastic) tubing. Slide one end of the tube onto the outlet of the barbed connector and secure with a clamp. Leave the other end of the tube lying on the floor of the base pan until the unit is positioned over the floor drain.

6. Route the drain tube. Either a) Insert the drain tube through the base pan into the floor drain or b) Route the drain tube through the left hole in the lower back panel and connect to barbed elbow and secure with a clamp.

7. Reinstall the upper back panel.

8. Reinstall the service access panel. Level the unit.

---

**IMPORTANT NOTE:** Often an air gap is required by local codes between the ice maker drain tube and the drain receptacle.

---

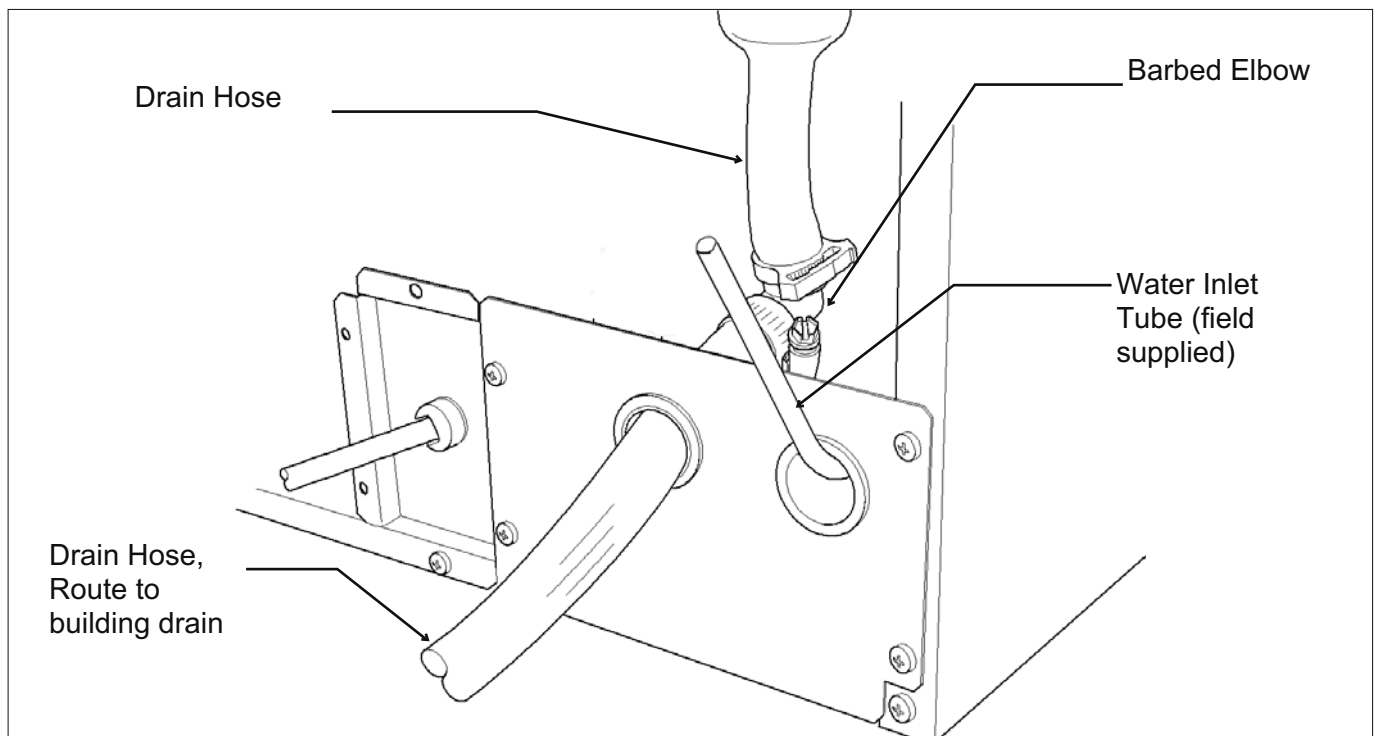

Back View, Gravity Drain Model

# SCCG30 & SCCP30

## User Manual

### Electrical

---

The ice machine is supplied with a power cord. Do not remove the grounding pin from the cord's plug. Do not use extension cords. Follow all codes. Connect the machine to its own 115 volt, 15 amp circuit.

1. If the electrical outlet for the ice maker is behind the unit, plug in the unit.
2. Position the unit in the installation opening.
3. Turn on the water supply. Make sure that the ice maker is plugged in and the power is on.
4. Slide unit into installation opening, paying careful attention to water supply and drain connections. Do not kink!
5. Pour a couple of quarts of water into the ice storage bin; on units equipped with a drain pump the drain pump should start and water should pump out. Check for leaks and proper draining.
6. Replace the service access panel. Level the unit as needed.

### Initial Start Up

1. Turn on the water supply.
2. Switch on the electrical power.
3. Switch the on/off switch to On.

The compressor will start and water will begin to flow into the unit. When the reservoir is full, water will start to drain from the machine. After a few minutes the water pump and fan motor will begin to operate and the first ice making cycle will have begun.

No adjustments are needed.

After about a half hour, ice will fall into the ice storage bin. The first batches of ice will melt, this is normal. It will take 24 to 36 hours of continuous run time to fill the ice storage bin. When the bin is full of ice, the ice machine will shut off. It will automatically restart when the ice level falls, either from use or meltage.

### Installation check list:

Has the unit been connected to the proper water supply?

Has the water supply be checked for leaks?

Has the unit been connected to a drain?

Has the drain been tested for flow and leaks?

Has the unit been connected to the proper electrical supply?

Has the unit been leveled?

Have all packing materials been removed from the machine?

Has the door covering been installed?

# SCCG30 & SCCP30

## User Manual

### Use

---

No special instructions are needed for use. Just take as much ice as you need, the machine will replace it. A scoop is provided, and it can be stored in the machine using the loop of tubing on the right side as a holder.

#### What shouldn't be done?

Never keep anything in the ice storage bin that is not ice; objects like wine or beer bottles are not only unsanitary, but the labels may slip off and plug up the drain.

Never allow the machine to operate without regular cleaning. The machine will last longer if it is kept clean. Regular cleaning should happen at least once per year, and preferably twice. Some water conditions will dictate even more frequent cleaning of the ice making section, and some carpets or pets will dictate more frequent cleaning of the condenser.

#### Noise:

The ice machine is designed for quiet operation, but will make some noise during the ice making cycle. It is normal to hear the fan and circulating water during the freeze cycle, and ice hitting the bin or ice in the bin can be heard during harvest.

If ice making noise is objectionable, a timer can be added to the power supply. Set the timer to turn the machine off at the time of day when the noise is most objectionable.

### Maintenance

There are 5 things to keep clean:

1. The outside cabinet & door.
2. The ice storage bin.
3. The condenser.
4. The ice making system.
5. The ice scoop.

#### *How to clean the cabinet.*

Wipe off any spills on the surface of the door and handle as they occur. If anything spilled on the door or gasket dries onto the surface, wash with soap and warm water to remove.

#### *How to clean the ice storage bin.*

The ice storage bin should be sanitized occasionally. It is usually convenient to sanitize the bin after the ice making system has been cleaned, and the storage bin is empty.

A sanitizing solution can be made of 1 ounce of household bleach and two gallons of hot (95°F. – 115°F.) water. Use a clean cloth and wipe the interior of the ice storage bin with the sanitizing solution, pour some of the solution down the drain.

Allow to air dry.

## SCCG30 & SCCP30

### User Manual

#### How to clean the condenser.

---

The condenser is like the radiator on a car, it has fins and tubes that can become clogged. To clean:

1. Remove the kickplate.
2. Locate the condenser surface.
3. Vacuum the surface, removing all dust and lint.

Caution: Do not dent the fins.

4. Replace the kickplate.

#### *Winterizing*

1. Clean the machine as explained on the next page.
2. Open the door and switch the machine off.
3. Turn off the water supply.
4. Drain the water reservoir by removing the rubber cap on the back wall of the ice storage bin.
5. Disconnect the incoming water line at the inlet water valve.
6. Switch the machine to On.
7. Blow air through the inlet water valve until water stops flowing from it; a tire pump could do the job.
8. Drain pump models should have about 1/2 gallon of RV antifreeze (propylene glycol) poured into the ice storage bin drain.

---

Note: Automotive antifreeze must NOT be used.

---

9. Switch off and unplug the machine.

#### How to clean the ice making system.

1. Scoop out all of the ice, either discard it or save it in a ice chest or cooler.
2. Pour 8 ounces of Scotsman Ice Machine Scale Remover (available from a local Scotsman Distributor or Dealer) into the ice machine reservoir.
3. Allow the machine to operate for about 2 hours.
4. Pour hot (95°F. – 115°F.) water into the bin to melt the ice that has formed. That ice will likely be white and frosty looking.
5. Clean the bin liner of mineral scale by mixing some ice machine scale remover with hot water, and using that solution to scrub the scale off of the liner.
6. Rinse the liner with hot water.
7. Sanitize the bin interior.
8. Replace the ice removed in step 2.

The ice scoop should be washed regularly, wash it just like any other food container.

#### What to do before calling for service

Ice cubes are incompletely formed

- Clean the ice making system

Low capacity

- Check for restricted drain or standing water in the bin
- Clean the air cooled condenser fins

No ice

- Check on-off switch
- Check electrical breaker
- Check water supply

***Scotsman***<sup>®</sup>

SCOTSMAN ICE SYSTEMS

775 Corporate Woods Parkway, Vernon Hills, IL 60061

800-533-6006

[www.scotsman-ice.com](http://www.scotsman-ice.com)

17-3191-01