

# SCE170 SERVICE PARTS

This is the parts list for the SCE170. When looking up part numbers, always check the complete model and serial numbers to be certain of ordering the correct parts.

The SCE170 has been manufactured in A, B and C series configurations. It has also been manufactured in 50 and 60 Hz.

60 Hz model numbers end in -1, 50 Hz in -6.

Model number examples include:

- SCE170A-1A - A Series (Copeland Compressor)
- SCE170A-1B - B series (Tecumseh Compressor)
- SCE170W-1C - C series (water cooled condenser change)
- SCE170A-1H - H series color change
- SCE170W-1H - H series color change

Plastic tubing that has a length measurement in the description is sold by the foot, order 1 unit, and 1 foot will be shipped. Order enough to cover the length required. Lengths of tubing are listed under the description column.

## TABLE OF CONTENTS

Cabinet . . . . .	Page 2
Air cooled refrigeration . . . . .	Page 3
Water cooled refrigeration . . . . .	Page 4
Refrigeration . . . . .	Page 5
Water & Control System . . . . .	Page 6
Control box . . . . .	Page 8
Wiring diagrams . . . . .	Page 9

# SCE170 SERVICE PARTS

## CABINET

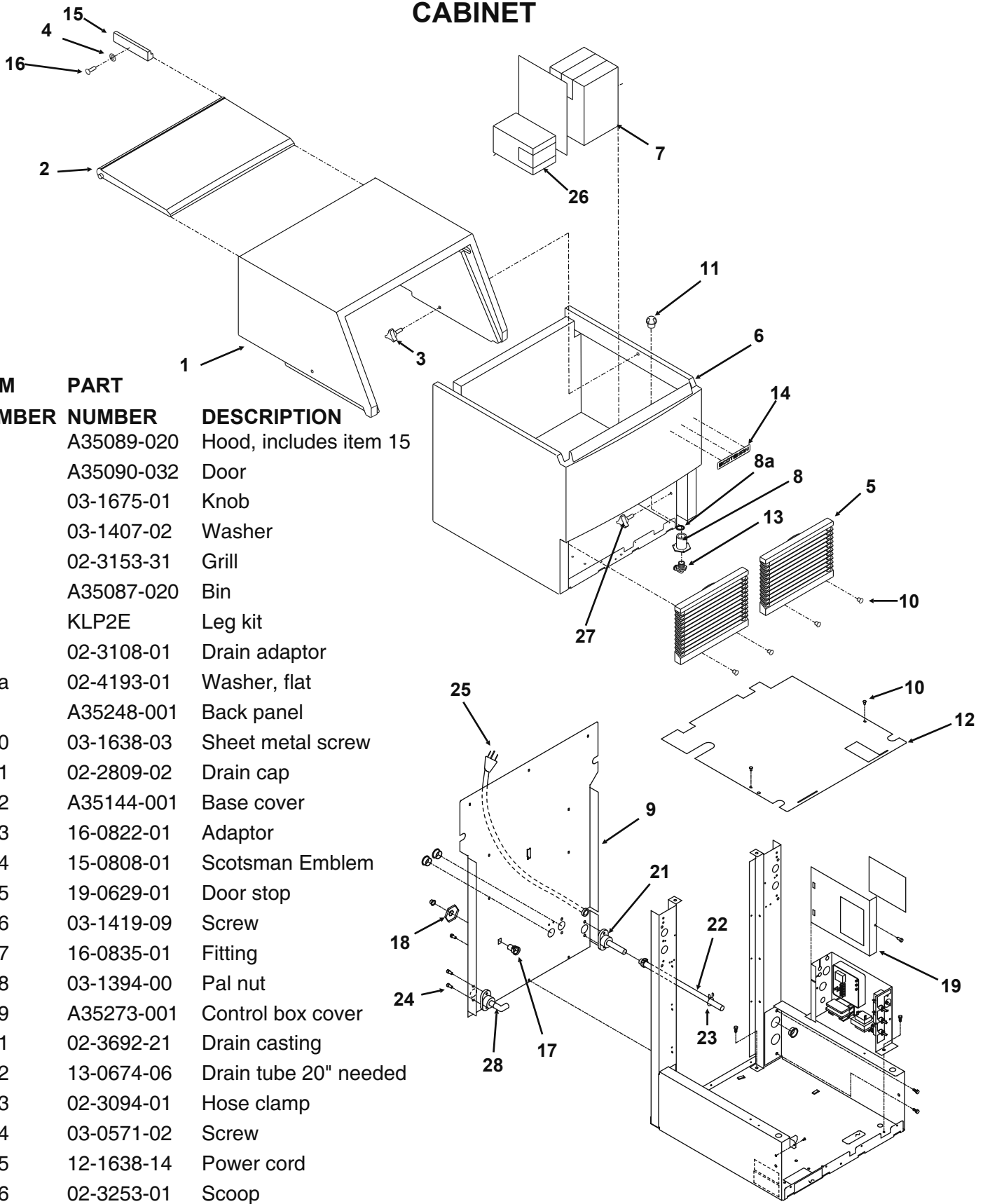

ITEM NUMBER	PART NUMBER	DESCRIPTION
1	A35089-020	Hood, includes item 15
2	A35090-032	Door
3	03-1675-01	Knob
4	03-1407-02	Washer
5	02-3153-31	Grill
6	A35087-020	Bin
7	KLP2E	Leg kit
8	02-3108-01	Drain adaptor
8a	02-4193-01	Washer, flat
9	A35248-001	Back panel
10	03-1638-03	Sheet metal screw
11	02-2809-02	Drain cap
12	A35144-001	Base cover
13	16-0822-01	Adaptor
14	15-0808-01	Scotsman Emblem
15	19-0629-01	Door stop
16	03-1419-09	Screw
17	16-0835-01	Fitting
18	03-1394-00	Pal nut
19	A35273-001	Control box cover
21	02-3692-21	Drain casting
22	13-0674-06	Drain tube 20" needed
23	02-3094-01	Hose clamp
24	03-0571-02	Screw
25	12-1638-14	Power cord
26	02-3253-01	Scoop
27	03-1675-02	Bin bolt
28	A31828-005	Drain casting, no el
	16-0239-01	5/8" street el

28      02-3692-21      Drain casting, plastic

Note: If switching item 28 from brass to plastic, item 23 on page 6 must be shortened. routed and rotated to fit.

# SCE170 SERVICE PARTS

## Air Cooled Refrigeration

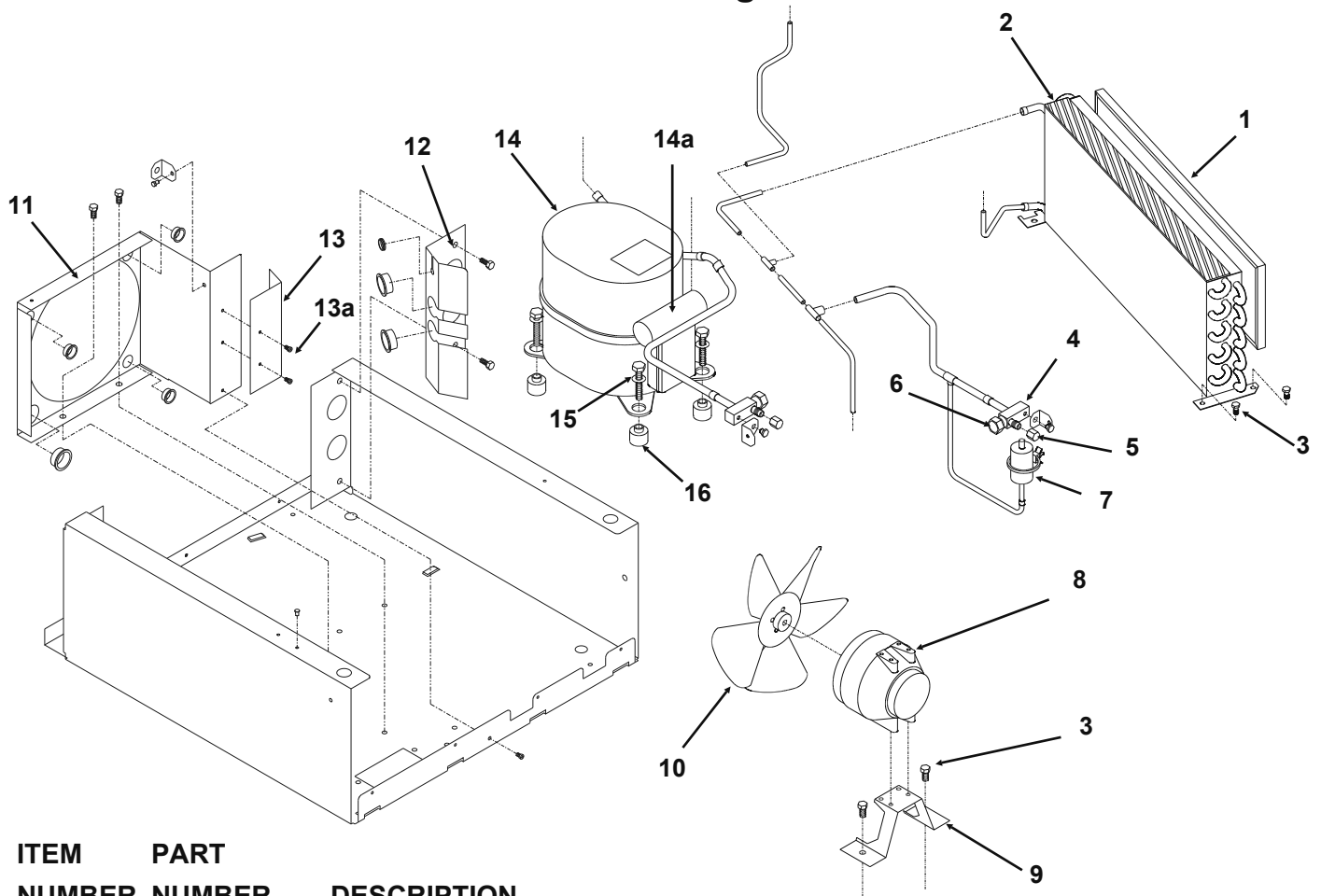

ITEM NUMBER	PART NUMBER	DESCRIPTION
1	02-3193-01	Air filter
2	18-8501-01	AC Condenser for A
	18-8844-01	AC Cond for B, C or H
3	03-0571-02	Screw
4	16-0832-20	Access valve
5	16-0832-03	Core cap
6	16-0832-02	Stem cap
7	11-0501-22	Hi press. cut out
8	12-1681-23	Fan motor, 115 volt
	12-1681-04	Fan motor, 230 volt
9	A35246-001	Fan motor bracket
10	18-8708-01	Fan blade
11	A35261-001	Fan shroud
12	A35262-001	Divider
13	A35274-001	Filter bracket
13a	03-1638-03	Screw
14	A37824-021	115 volt compressor kit
	18-8831-26	230/50/1 compressor kit
includes relay, overload, drier and start capacitor		

ITEM NUMBER	PART NUMBER	DESCRIPTION
14a	115/60/1 Copeland Starting Components	
	18-1901-15	Start capacitor
	18-1903-49	Relay
	18-8703-50	Overload
	115/60/1 Tecumseh Starting Components	
	18-8831-29	Start capacitor
	18-8831-28	Start relay
	18-8831-27	Overload
	230/50/1 Tecumseh starting components	
	18-8831-25	Start capacitor
	18-8831-24	Start relay
	18-8831-23	Overload
Compressor Mounting Hardware:		
15	03-1677-01	Screw
	03-1407-07	Washer
	18-2200-27	Sleeve
16	18-2200-28	Grommet

# SCE170 SERVICE PARTS

## Water Cooled Refrigeration

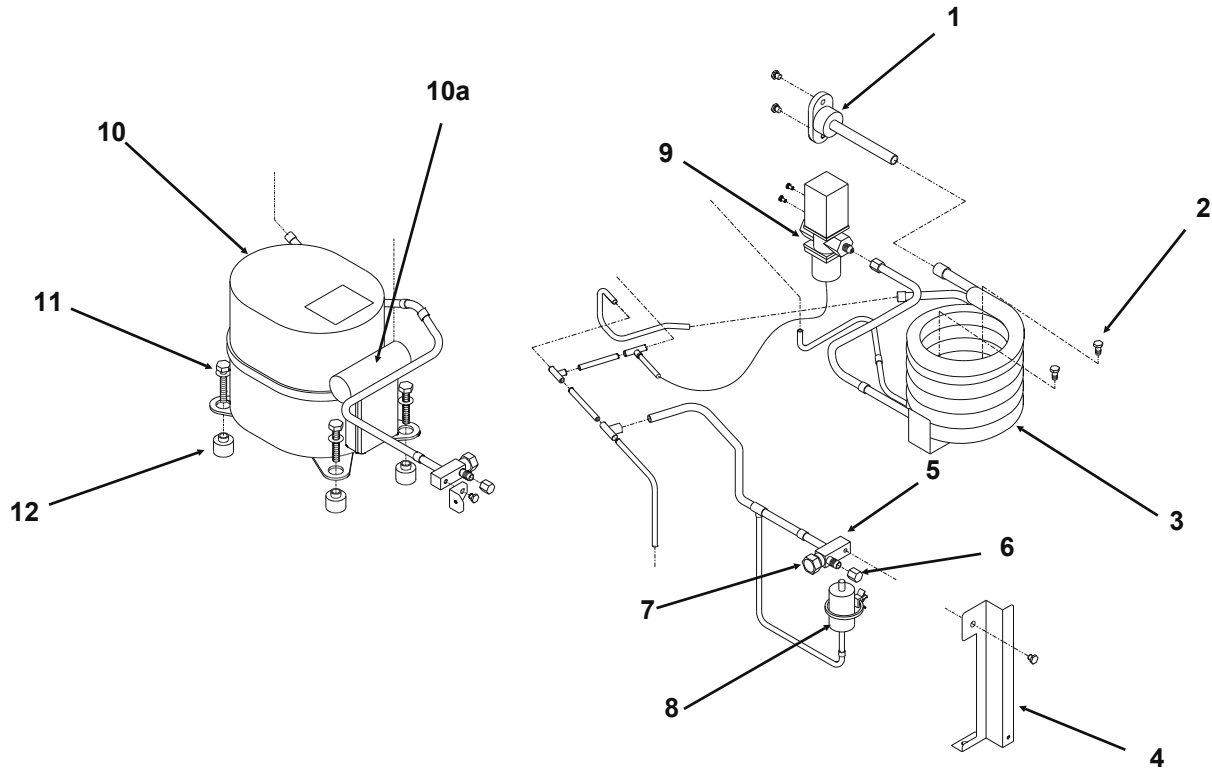

ITEM NUMBER	PART NUMBER	DESCRIPTION
1	A31828-002	Drain casting
2	03-0571-02	Screw
3	18-3707-25	WC Condenser for A
	18-3303-02	WC Condenser for B
	18-8869-21	WC Condenser for C or H
4	A35642-001	Bracket
5	16-0832-20	Access valve
6	16-0832-03	Core cap
7	16-0832-02	Stem cap
8	11-0487-21	Hi press. cut out
9	11-0478-01	Water regulating valve
10	A37824-021	115 volt compressor kit
	18-8831-26	230/50/1 compressor kit
includes relay, overload, drier and start capacitor		

ITEM NUMBER	PART NUMBER	DESCRIPTION
10a	Copeland Starting Components	
	18-1901-15	Start capacitor
	18-1903-49	Relay
	18-8703-50	Overload
	115/60/1 Tecumseh Starting Components	
	18-8831-29	Start capacitor
	18-8831-28	Start relay
	18-8831-27	Overload
	230/50/1 Tecumseh starting components	
	18-8831-25	Start capacitor
	18-8831-24	Start relay
	18-8831-23	Overload
Compressor Mounting Hardware:		
11	03-1677-01	Screw
	03-1407-07	Washer
	18-2200-27	Sleeve
12	18-2200-28	Grommet

# SCE170 SERVICE PARTS

## Refrigeration System

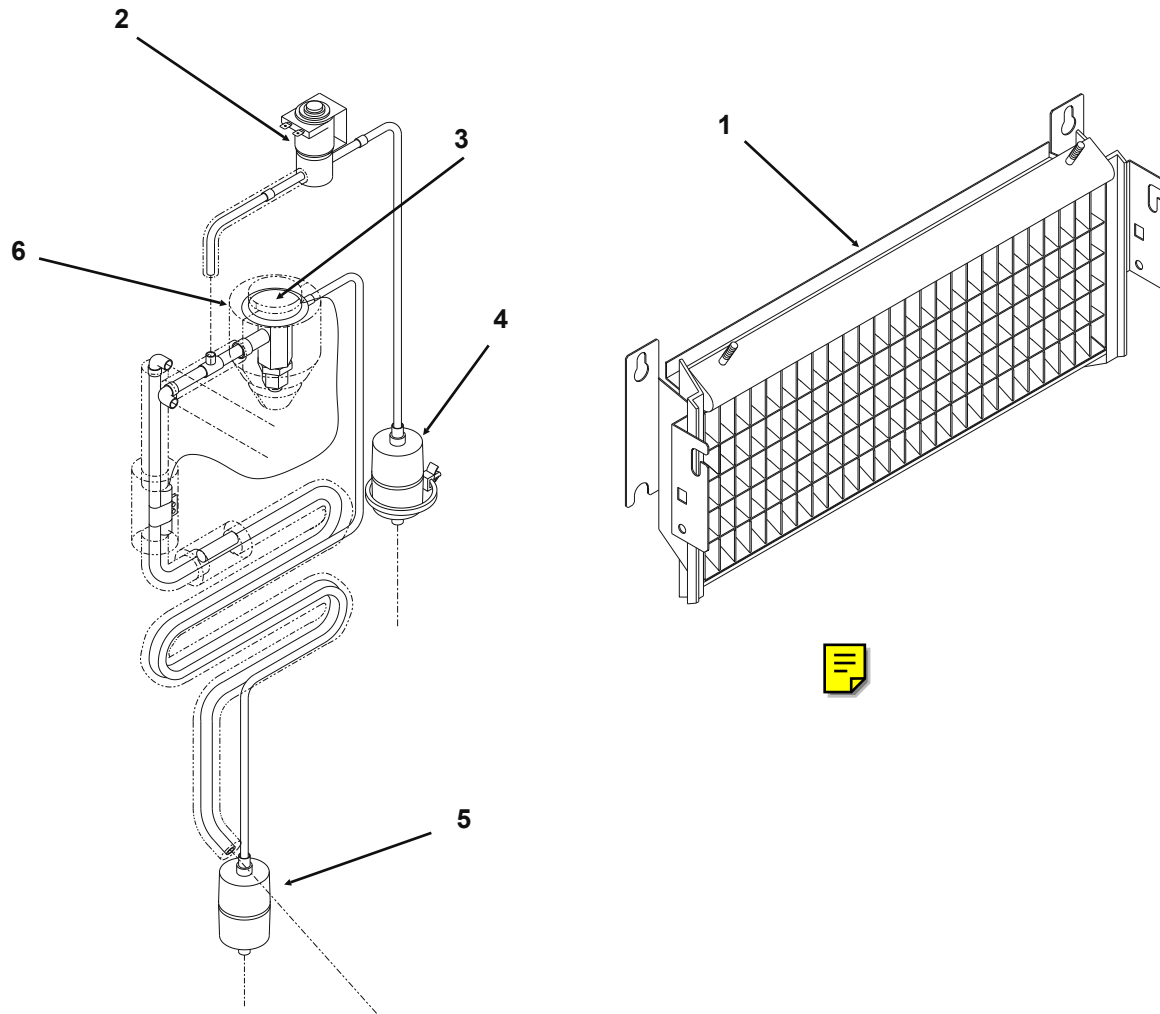

ITEM NUMBER	PART NUMBER	DESCRIPTION
1	A35688-020	Evaporator
2	11-0475-21	Hot gas valve & coil, 115/60/1
	11-0475-22	Hot gas valve & coil, 230/50/1
3	16-0868-21	Thermo expansion valve for A series
	16-0868-22	TXV for B or C or H series. Replaces 16-0868-02, 16-0868-03 or 18-0868-04 valves - locate bulb next to cube size control bulb.
4	02-3231-01	Hot gas valve filter
5	02-3319-01	Dryer
6	A36067-001	Insulation

# SCE170 SERVICE PARTS

## Water & Control System

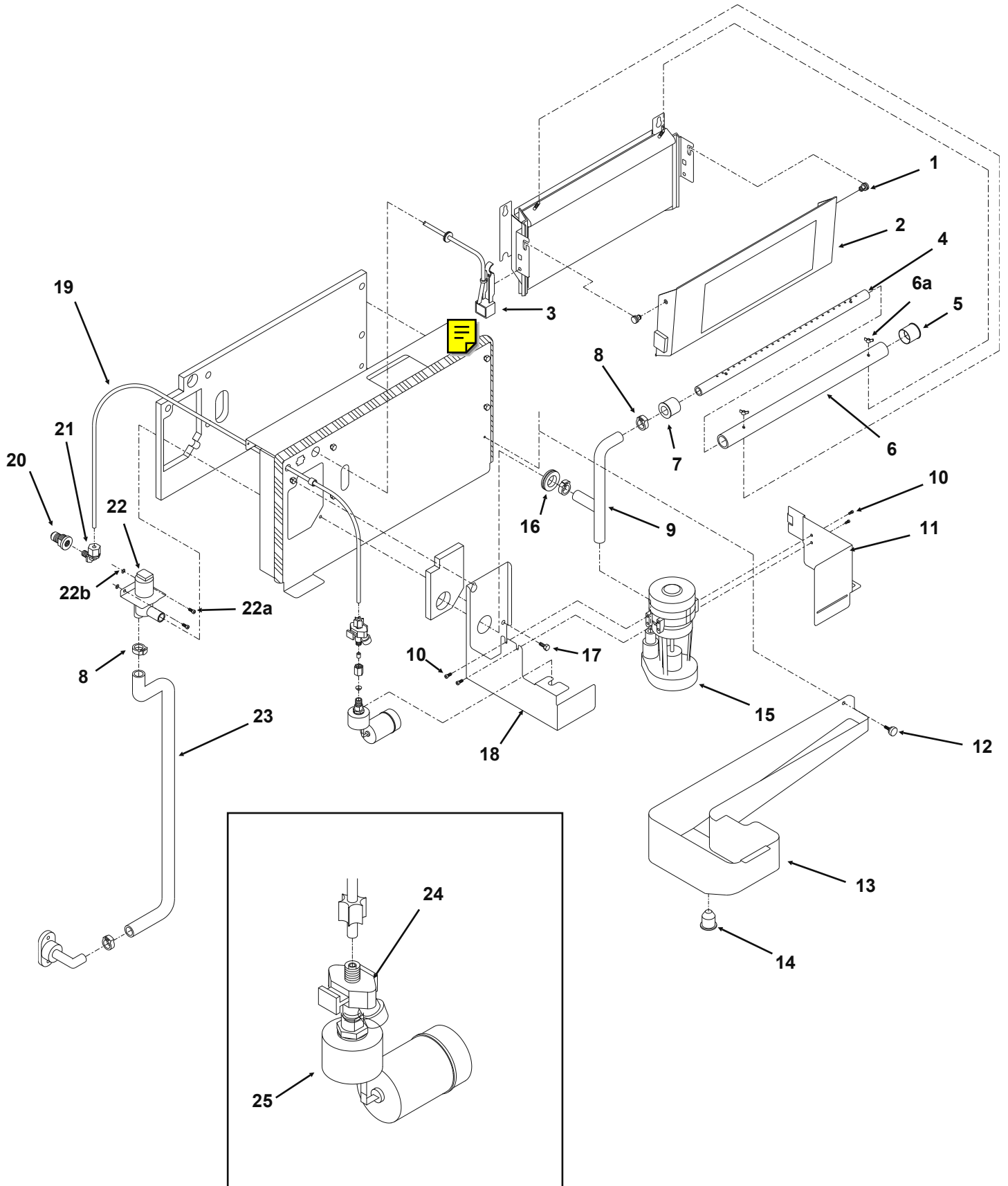

# SCE170 SERVICE PARTS

## Water & Control System

ITEM NUMBER	PART NUMBER	DESCRIPTION
1	02-3278-01	Hinge pin
2	02-3279-01	Curtain
3	12-2436-22	Curtain sensor
4	02-3295-01	Inner water tube
5	02-3281-01	Right end cap
6	02-3294-01	Outer water tube
6a	03-0255-02	SS wing nut
7	A35669-001	Left end fitting
8	02-2814-08	Hose clamp
9	02-3280-01	Pump hose
10	no number	#8 - 36 ¼" stainless steel machine screw
11	A35686-001	Pump shield
12	03-0727-09	Thumb screw
13	02-3276-01	Reservoir
14	13-0840-01	Drain plug
15	12-2419-71	Water pump, 115/60/1
	12-2419-75	Water pump, 230/50/1
16	13-0896-01	Grommet
17	03-0571-02	Screw
18	A35680-001	Pump bracket
19	13-0895-01	Water inlet tube, 40" needed
20	16-0835-01	Water inlet fitting
21	16-0837-01	Elbow fitting
22	11-0480-01	Purge valve, 115/60/1
	11-0480-02	Purge valve, 230/50/1
22a	03-1638-03	Screw
22b	03-1684-01	Retaining washer
23	02-3287-01	Purge drain tube
24	no number	Water shut off valve - part of item 25
25	02-3612-01	Float valve, includes item 24.

# SCE170 SERVICE PARTS

## Control Box

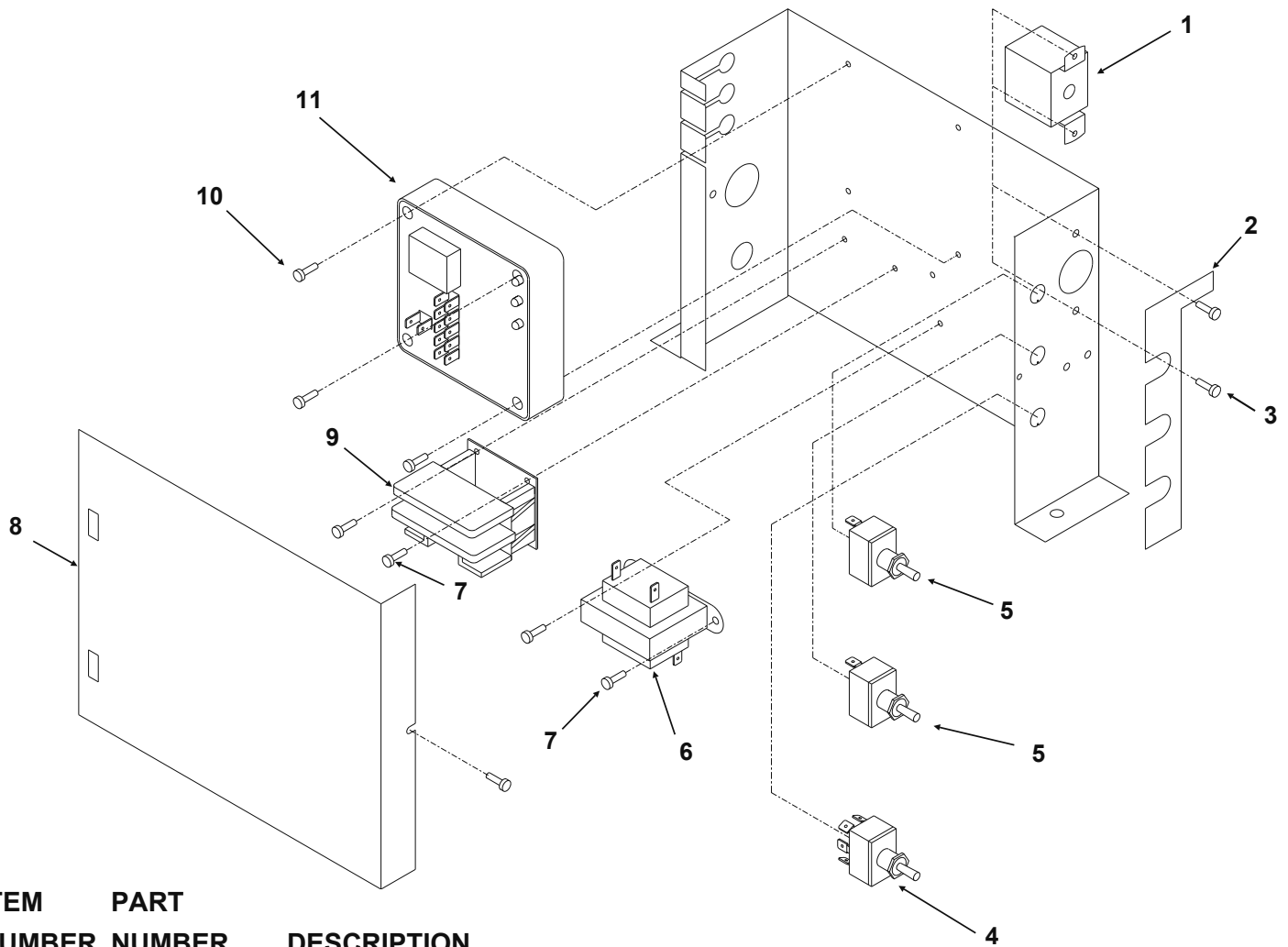

ITEM NUMBER	PART NUMBER	DESCRIPTION
1	11-0370-20	Cube Size Control (bridge thickness)
2	no number	Control box label
3	03-1683-03	Screw
4	12-2255-01	Toggle switch, DPDT
5	12-2426-01	Toggle switch, SPST
6	12-2285-21	Transformer 115 to 12 volt
	12-2639-01	Transformer, 230 to 12 volt
7	03-1638-04	Screw
8	A35273-001	Control box cover
9	12-2469-03	Contactor, 115 volt coil
	12-2469-02	Contactor, 230 volt coil
10	03-1419-09	Screw
11	12-2436-21	Control module
Not Shown		
12	12-2686-01	Fuse, only used on 50 Hz
	12-2687-01	Fuse holder, only used on 50 Hz



# SCE170 SERVICE PARTS

## Wiring Diagram

### 115/60/1 Air or Water Cooled

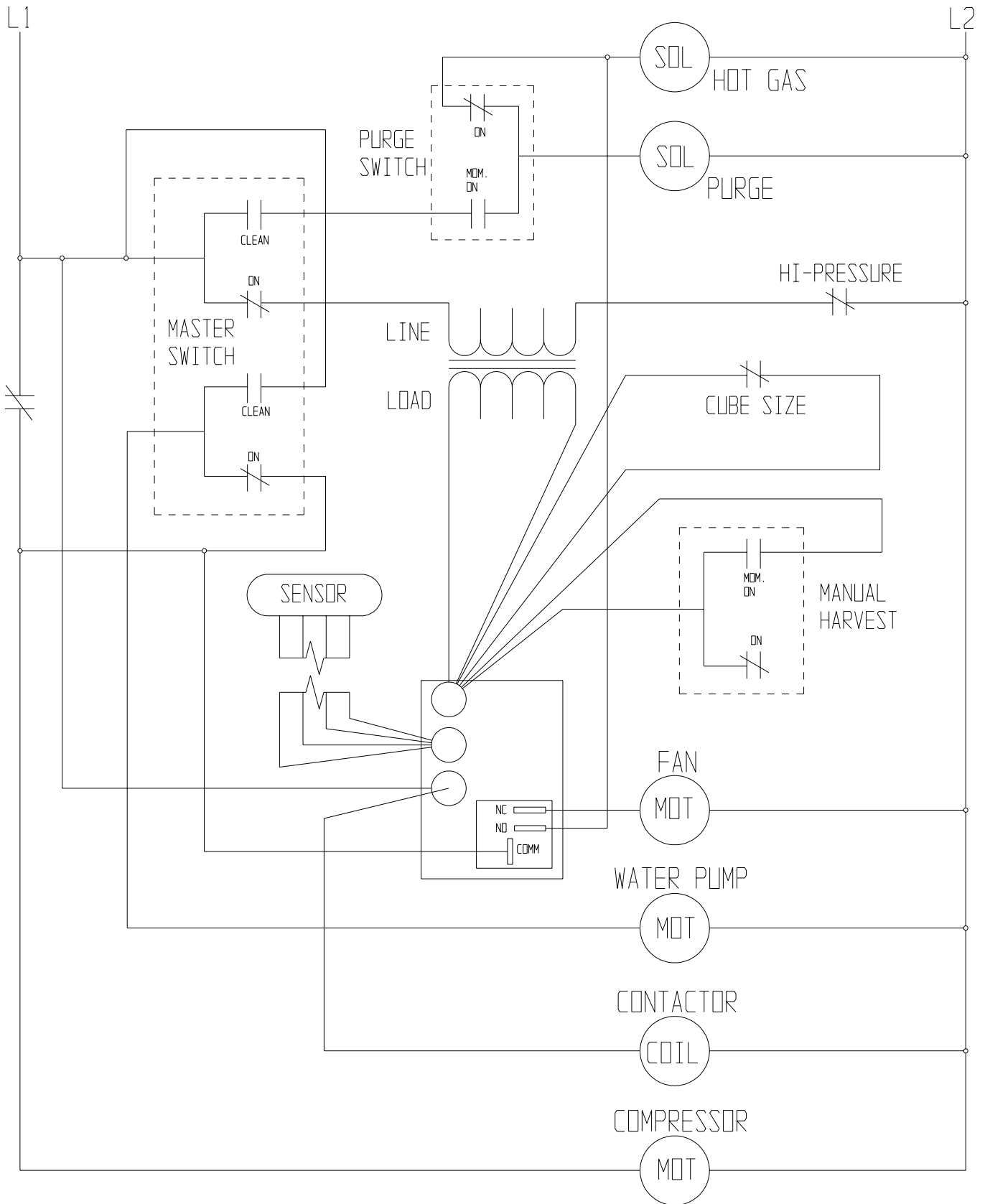

# SCE170 SERVICE PARTS

## Wiring Diagram

### 115/60/1 Air or Water Cooled

A36257-001

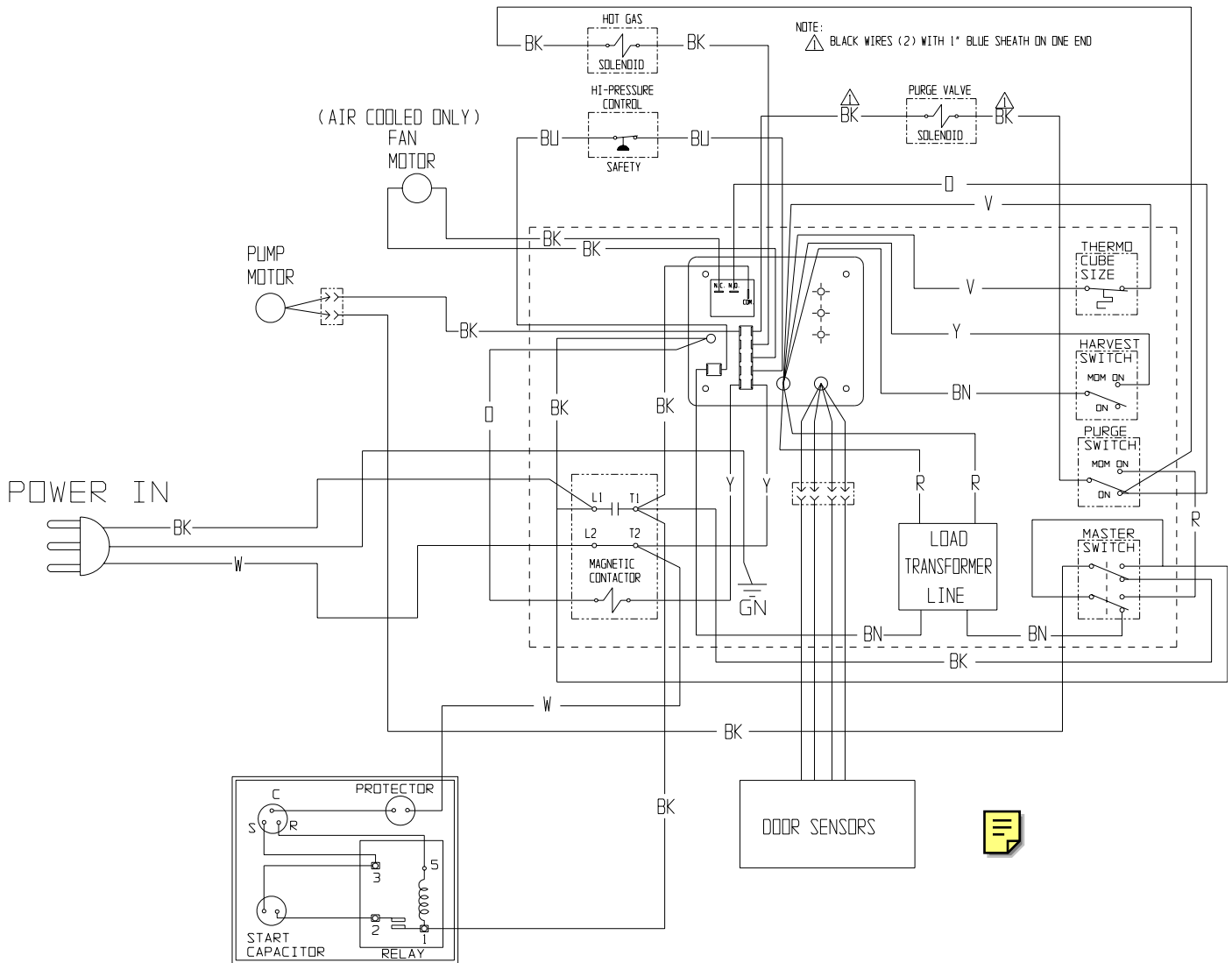

**Note: Shown in Timed Portion of Freeze Cycle  
Manual Purge Only Works in Clean**

# SCE170 SERVICE PARTS

## 230/50/1 Wiring Diagram

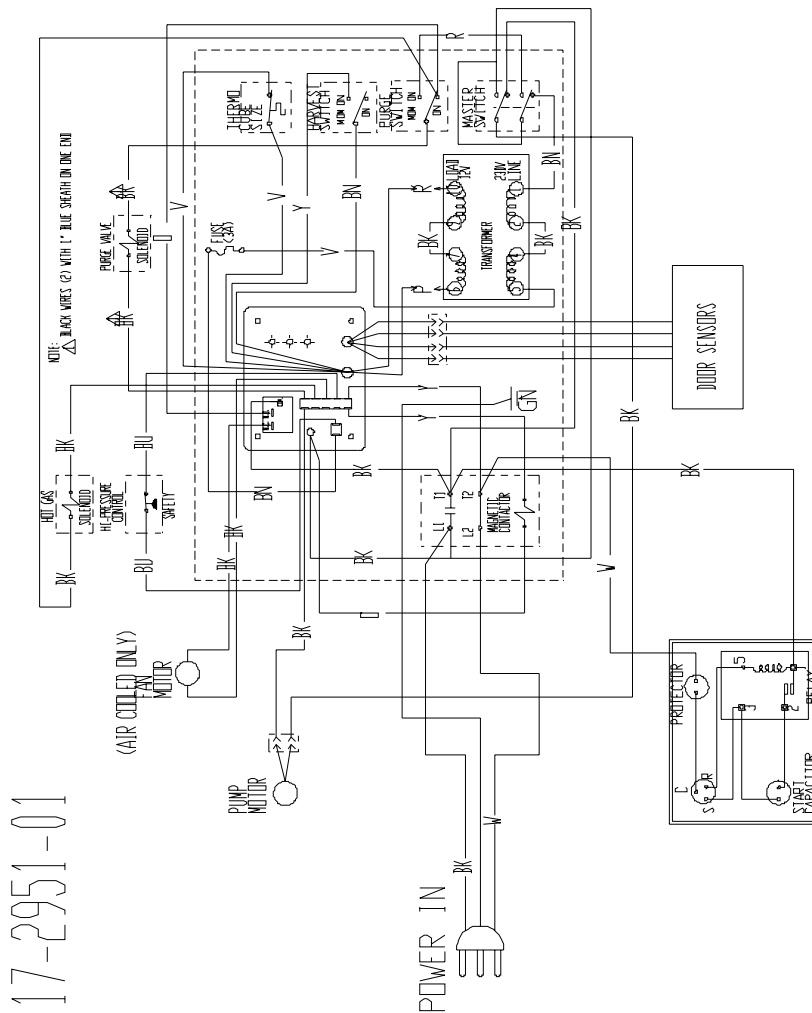
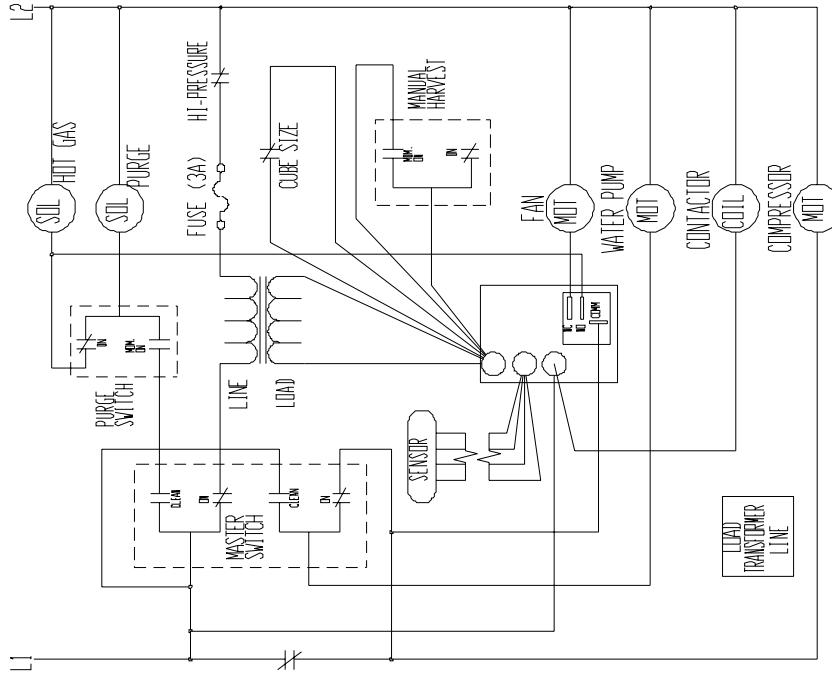

17-2951-01

NOTE: SHOWN IN TIMED PORTION OF FREEZE CYCLE  
MANUAL PURGE ONLY WORKS IN CLEAN

**SCOTSMAN**

Bulletin Number: PS - 10 - 98

Bulletin Date: October 1998

## SERVICE BULLETIN

### Subject: SCE170 Air Cooled High Pressure Cut Out Change

Beginning with serial numbers ending in -04B (October 1998 production), the high pressure cut out (also called the high pressure control) has been changed from a manual reset to an **automatic reset**.

When replacing a defective high pressure cut out on an air cooled SCE170, replace the old switch (part number 11-0485-22 - cut out at 450 PSIG), with the **new** switch, part number **11-0501-22** (cut out at 450 PSIG, cut in at 350 PSIG).

Although the new cut out connects to the machine's wiring in the same place as the original's, when replacing a manual reset cut out, quick connects will have to be added to the existing wires so they can be plugged onto the new switch. Also, part number 11-0485-22 will continue to be used as a service part for other products.

---

# SERVICE BULLETIN

---

**Subject: SCE170 B Series**

The SCE170 has had a model series revision. The new models are SCE170A-1B and SCE170W-1B. The changes are in the refrigeration system and include a new compressor.

New Parts for the B series:

Compressor Kit .....	A37824-021
Start Capacitor .....	18-8831-29
Relay .....	18-8831-28
Overload .....	18-8831-27
Air Cooled Condenser.....	18-8844-01
Water Cooled Condenser.....	18-3303-02
Thermostatic Expansion Valve.....	16-0868-22

The A37824-021 compressor kit (Tecumseh) replaces the prior Copeland compressor, which is no longer available. The kit includes the new compressor (plus relay, capacitor, overload and a drier) and the necessary tubing to connect it to the refrigeration system of the A series. Refer to the instructions that are included with the kit for detailed information.

The B series refrigerant charge has changed from the A series:

Air cooled B series is 16 ounces

Water cooled B series is 11 ounces, both remain R-404A.



---

Bulletin Number: PS - 13 - 2001  
Bulletin Date: December 2001

---

# SERVICE BULLETIN

---

## **SUBJECT: Thermostatic Expansion Valve Changes**

**SCE170 B Series:** The replacement TXV for this series machine has been changed. Although the service kit part number remains 16-0868-22, the TXV supplied in the kit is now part number 16-0868-03.

When installing a 16-0868-03 TXV on a **B series SCE170 that had the prior valve**, relocate the TXV bulb from its vertical suction line location to the horizontal suction line position, just to the right (when viewed from the back) of the cube size control bulb.

Production of SCE170s with this valve began in early November, 2001, and they have the TXV bulb next to the cube size control bulb, so they do not require bulb relocation when replacing the TXV.

The A series valve does not change.

**AFE400:** The replacement TXV for the AFE400 has been changed from 16-0996-01 to **16-1091-21**. These valves are completely interchangeable. Production of AFE400s with the new valve began in early December, 2001.