

## Introduction

---

To the owner or user: This service manual is intended to provide you, and the maintenance or service technician, with the information needed to install, start up, clean, maintain and repair this product.

The SCE275 is an ice machine that produces cubed ice on a vertical freezing surface. The cubes fall into the ice storage bin where they break up into individual cubes.

The SCE275 automatically maintains the level of ice by turning on when the ice level falls, and switches off when the bin is full.

This unit is serviceable in place; the ice storage bin and hood may be removed from the chassis to allow service access without removing the ice machine from its installed position. The refrigeration system uses R-404A as the refrigerant.

### Table of Contents

Specifications . . . . .	2
For The Installer: Environmental Limitations . . . . .	3
Installation . . . . .	4
Installation . . . . .	5
For The Plumber . . . . .	6
Installation . . . . .	7
Removal of the Cabinet . . . . .	8
Component Location . . . . .	9
Component Description . . . . .	10
AutoIQ Controller . . . . .	11
Initial Start Up . . . . .	12
Notes On Operation . . . . .	13
Adjustments . . . . .	14
How To Operate The AutoIQ Controller . . . . .	15
How The Electronic Cuber Works . . . . .	16
Water System . . . . .	17
Technicians Only: Freeze Cycle Operational Sequence . . . . .	18
Technicians Only: Harvest Cycle Operational Sequence . . . . .	19
Sanitizing and Water System Cleaning . . . . .	20
Sanitizing and Cleaning . . . . .	21
Additional Maintenance . . . . .	22
Additional Maintenance . . . . .	23
Additional Maintenance: Bin Controls . . . . .	24
Technical Characteristics . . . . .	25
Service Diagnosis . . . . .	26
Service Diagnosis . . . . .	27
Service Diagnosis . . . . .	28
PTCR . . . . .	29
Removal and Replacement: AutoIQ Controller . . . . .	30
Removal and Replacement: Water Pump, Water Level Sensor . . . . .	31
Removal and Replacement: Inlet Valve & Water Trough . . . . .	32
Removal and Replacement: Bin Control Set . . . . .	33
Removal and Replacement: Thermistors . . . . .	34
Water Distributors . . . . .	35
Refrigeration System Service: R-404A . . . . .	36

*This manual was printed on recycled paper.*

**Parts lists and wiring diagrams are located in the center of this manual.**

# SCE275

## Specifications

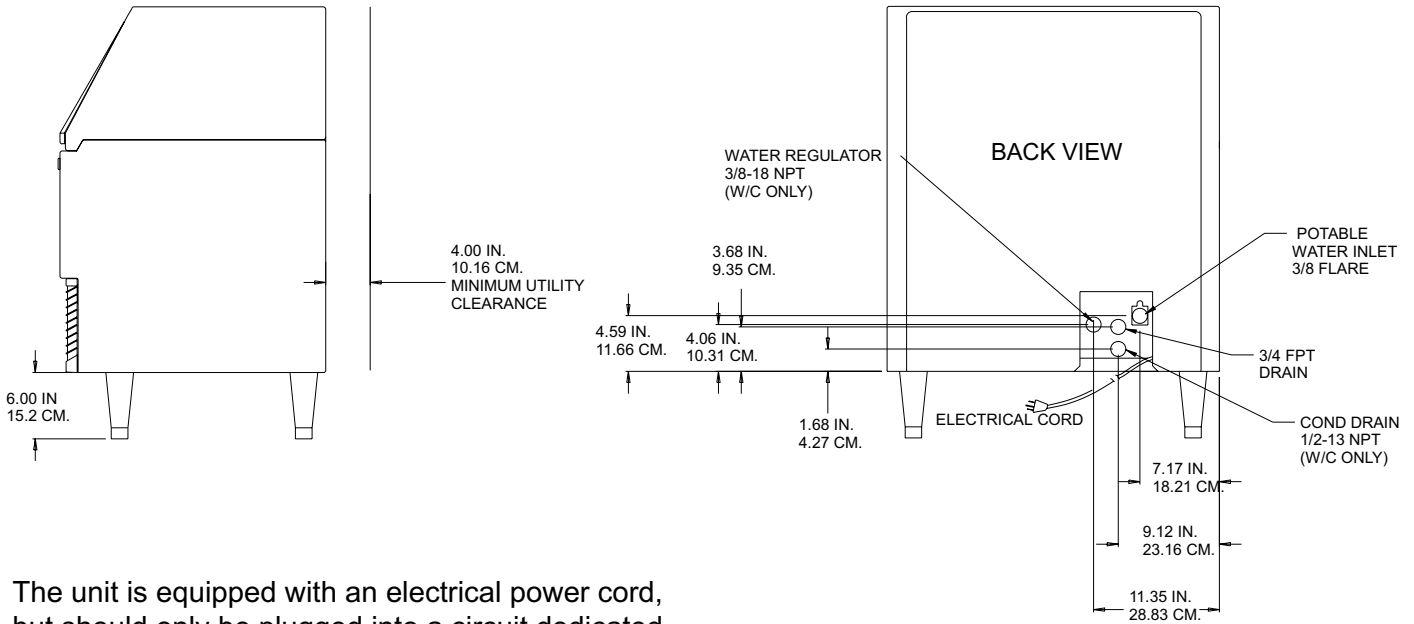

The unit is equipped with an electrical power cord, but should only be plugged into a circuit dedicated to the ice machine.

**THE NAMEPLATE IS LOCATED ON THE BACK PANEL**  
**A Serial Number Plate is Located on the Front Edge of the Base, Behind the Right Front Grill**

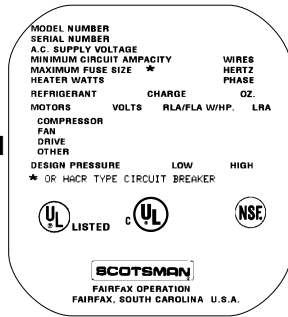

**Controller Location in G Series and Higher**

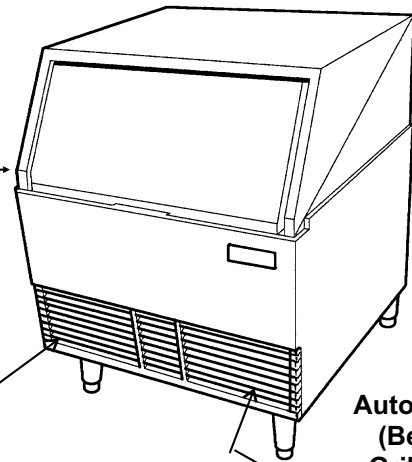

**AutoIQ Controller (Behind Right Grill in A thru F Series)**

Model Number	Dimensions (w/o legs) H" x W" x D"	Basic Electrical	Condenser Type	Total Load Amps	Total Unit Wattage	Refrigerant R-404A (HP62)
SCE275A-1G	33 x 30 $\frac{1}{4}$ x 30	115/60/1	Air	15		18 ounces
SCE275A-32G	33 x 30 $\frac{1}{4}$ x 30	208-230/60/1	Air	8.4		18 ounces
SCE275W-1G	33 x 30 $\frac{1}{4}$ x 30	115/60/1	Water	15		12 ounces
SCE275A-6G	33 x 30 $\frac{1}{4}$ x 30	230/50/1	Air	7.5	1725	18 ounces
SCE275W-6G	33 x 30 $\frac{1}{4}$ x 30	230/50/1	Water	7.5	1725	12 ounces

## For The Installer: Environmental Limitations

The ice machine must be installed indoors in a controlled environment.

	Min	Max
Air Temp	50 <sup>0</sup> F.	100 <sup>0</sup> F.
Water Temp	40 <sup>0</sup> F.	100 <sup>0</sup> F.
Water Pressure	20 PSI	80 PSI
Voltage (60 Hz)	103.5	126.5
Voltage (50 Hz)	207	253

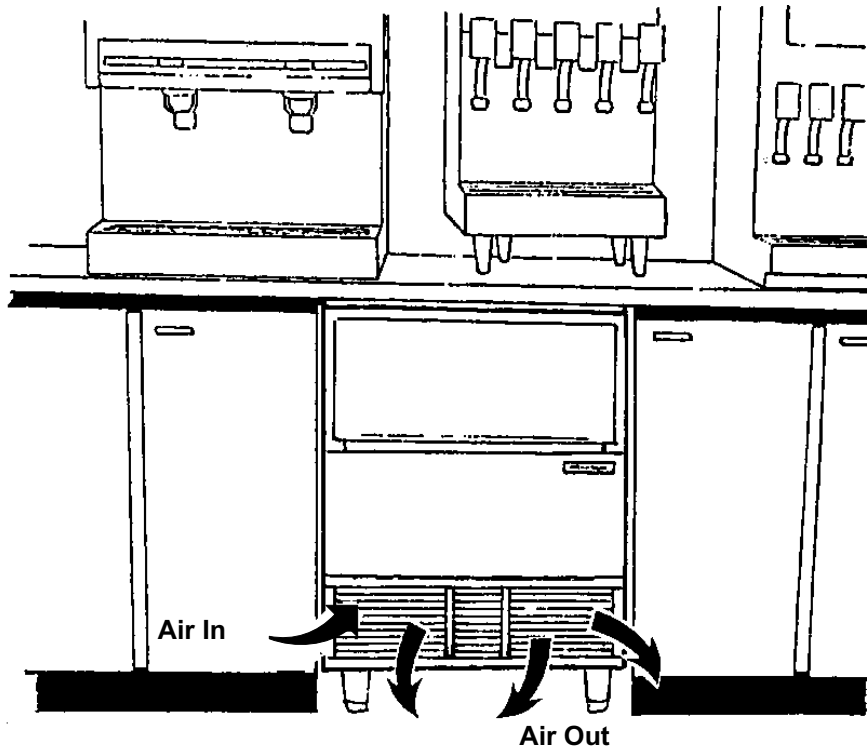

Operating the ice machine outside of the above limitations, or outdoors, is potentially damaging to the machine, and it is misuse of the machine. This may void the warranty.

Scotsman Ice Systems are designed and manufactured with the highest regard for safety and performance. They meet or exceed the standards of UL, NSF, and CUL

Scotsman assumes no liability or responsibility of any kind for products manufactured by Scotsman that have been altered in any way, including the use of any part and/or other components not specifically approved by Scotsman.

Scotsman reserves the right to make design changes and/or improvements at any time.

Specifications and design are subject to change without notice.

Airflow on air cooled models is:

Intake through the left front grill.

Exhaust through the right front grill.

Do not install where this air flow is obstructed.

The SCE275 has a removable cabinet. When installed, the machine should have some extra clearance ( $\frac{1}{8}$ " ) on the left and right sides so that the cabinet may be easily removed when the machine is in place.

# SCE275

## Installation

### Water

The water supply for this ice machine has been in contact with many materials since it fell from the sky as rain. All rain is slightly acidic, and tends to dissolve the materials it comes in contact with. During water's journey to the ice machine, it has flowed over and through the ground, been picked up by a municipal or private pump, forced through a series of pipes of differing construction and may have been treated by the municipality providing the water.

This means that there is no such thing as "pure" water. All water contains some level of impurity. There are two ways water carries the impurities: suspended and dissolved. Water filters can remove the suspended solids, but cannot remove the dissolved portion.

Cube ice machines use more water than is made into ice, the excess amount is used to dilute the concentration of minerals and "rinse" out the water system to keep the water scale from clogging up the machine. That water rinse, combined with water filters, prolongs the times between needed water system cleanings.

The water to the ice machine should be filtered. Water filters vary greatly in ability and function. Install one that filters out suspended solids to a dimension of 5 microns or less. The finer the filter the better, but finer filters may plug-up sooner than course ones. It may be necessary to add a course filter ahead of the fine filter to prolong filter life.

The SCE275 is factory set for a water purge that will work in most water conditions. While the amount of purge is adjustable, only change it if necessary.

Note: Water use adjustments are customer convenience adjustments; they are not factory defects and are NOT covered by warranty.

This ice machine may be installed in the open or under a counter. No clearance is required at the sides or top beyond what's needed to place the cabinet into position. Air cooled models blow air in and out through the grills at the front. Space is required for utility connections at the back.

**The ice machine is not designed for outdoor use. It must be installed indoors, in a controlled environment. The air and water temperatures must not exceed rated limits.**

Electrical power is supplied through a cord connected to the unit. All local codes must be followed.

### Pre-installation:

1. Inspect the place where the ice machine is to be installed. Check for:

- space for the cabinet,
- water supply,
- drain availability
- and electrical power supply.

No extension cords are allowed. The building drain inlet must be lower than the drain outlet(s) at the back of the ice machine. The water supply must have a hand shut off valve accessible when the unit is installed.

2. Determine the method of installation, is the machine to be installed under the counter? Is the drain in the floor under the machine? Is the water inlet valve accessible?

### Unpack and Assemble

1. Remove legs and scoop from storage bin.
2. Remove shipping materials from ice making area.

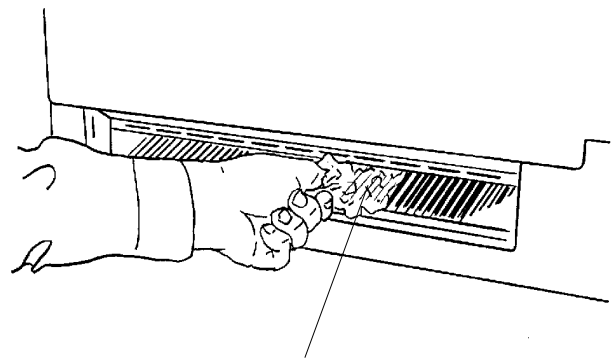

**Remove Material Located Between  
Cube Deflector and Troughs**

3. Place corner posts from the shipping carton on the floor behind the ice machine. Tip the ice machine on its back and remove the shipping skid.
4. Screw the legs into the threaded holes in the base of the ice machine.
5. Tip the ice machine back to an upright position.

## Installation

### For The Plumber

Begin by planning the installation and obtaining the needed supplies:

- $\frac{3}{8}$ " soft copper tubing
- $\frac{3}{4}$ " rigid drain tubing
- $\frac{3}{4}$ " FPT fitting for bin/reservoir drain connection
- $\frac{1}{2}$ " FPT fitting for condenser drain connection
- $\frac{3}{8}$ " FPT fitting for water cooled condenser inlet connection

1. Connect cold potable water to the  $\frac{3}{8}$ " male flare at the back of the cabinet. A water filter and hand shut off valve is recommended. Flush the water line prior to connecting to the ice machine.

If water cooled, connect a separate water inlet line to the water cooled condenser inlet fitting. It should also have a hand shut off valve.

A loop of copper tubing may be used between the ice machine and the water supply. This will allow the ice machine to be pulled out from its installed location without disconnecting the water line. No back-flow preventer should be needed in the inlet potable water line because provision for that is incorporated in this N.S.F. listed product (the water valve outlet is above the reservoir wall and cannot siphon).

2. Connect a drain tube to each drain connection (water cooled drain must be separate).
3. Route the drain tubes to the building drain receptacle.

**CONFORM TO ALL LOCAL CODES**

**Plumbing Connections,  
Water Cooled Shown**

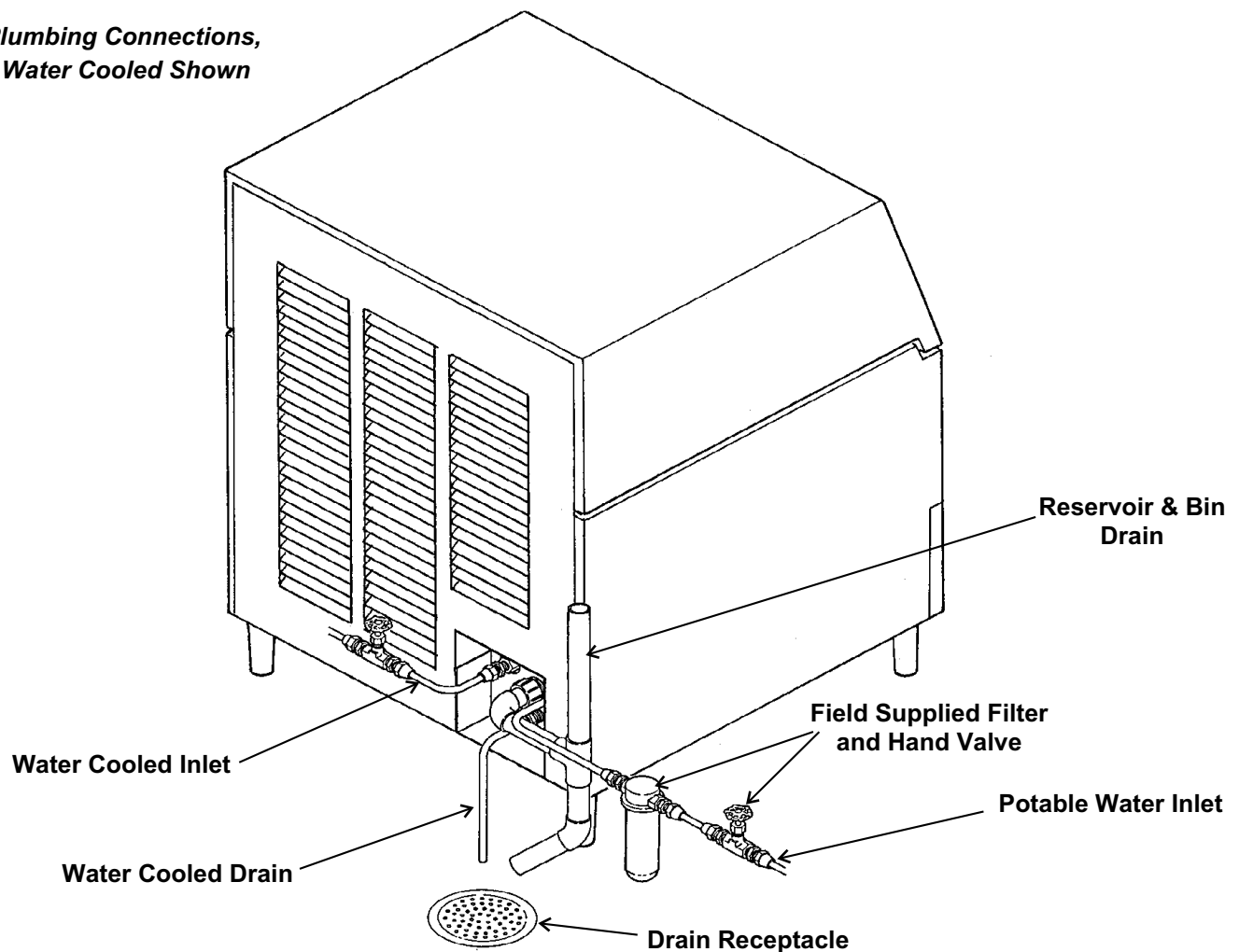

# SCE275

## For The Plumber

---

### Drain Configuration:

Water cooled models must use a separate drain tube from the reservoir/bin drain.

The water cooled condenser drain should not be vented.

Drain tube material must be rigid and meet local code.

Traps in the bin drain line without vents ahead of them will cause poor draining.

**The bin drain must be vented if there is a long horizontal run (5' or more).**

All drains are gravity, and must have a minimum fall of  $\frac{1}{4}$ " per foot of horizontal run.

**Maintain the air gap required by local code between the end of the drain tubes and the building drain receptacle.**

Note: Drain tubing should be insulated to prevent condensation from forming on the tubing.

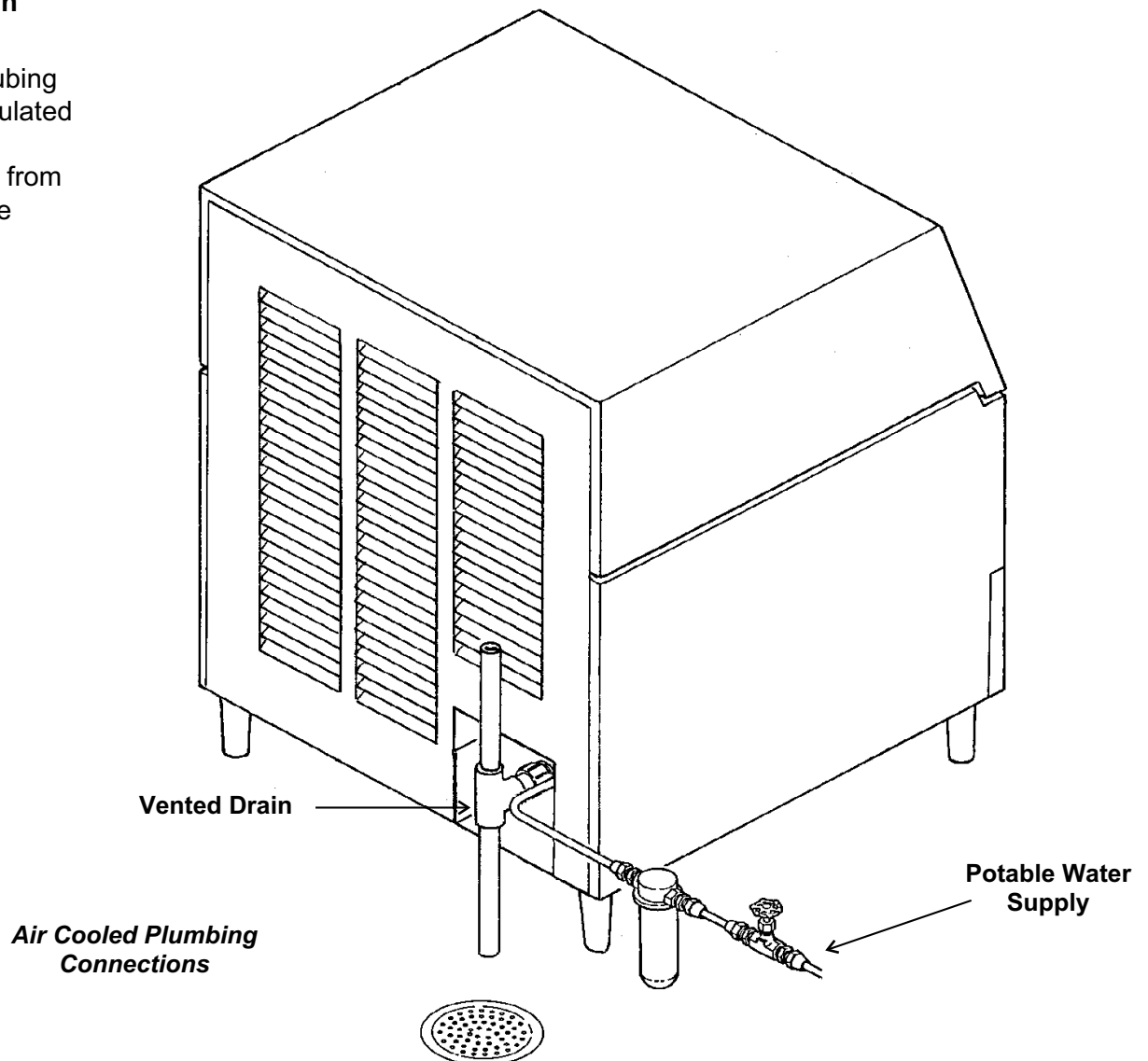

## Installation

---

### For The Electrician

The **115 volt, 60 Hz model** is a cord-connected unit, and must be on a separate 115 volt AC 60 cycle single phase power supply. The maximum fuse size for this circuit should be 15 amps. Per the nameplate use fuses, or HACR circuit breakers.

Connect **50 Hz models** to the correct voltage and fuses.

**Follow All Local Codes - This Unit Must Be Grounded.** Do not use extension cords and do not disable or by-pass ground prong on electrical plug.

### After Utility Connections:

1. Level the cabinet, use the leg levelers on the end of the legs to adjust the cabinet height. (Legs should have been installed when the unit was unpacked). Check for levelness at the reservoir.
2. Wash out the bin and hood. If desired, the interior of the bin could be sanitized.
3. Locate the scoop, wash it and have it available for use when needed.

### Final Check List

1. Is the ice maker cabinet in a room where ambient temperatures are within the minimum and maximum temperatures specified?
2. Has the water supply been connected?
3. Is the water pressure adequate?
4. Have the water connections been checked for water leaks?
5. Have the drain connections been made?
6. Have the drain connections been checked for leaks?
7. Is the cabinet level?
8. Is the ice machine plugged into an electrical power supply of the proper voltage and is the ice machine the only load on that circuit?
9. Has all of the shipping material been removed from the inside of the cabinet? **Check for materials between the cube deflector and the water troughs (see page 4). Be sure the cube deflector is in place.**
10. Has the bin and cabinet been wiped clean and sanitized?
11. Has the Customer Evaluation & Warranty Registration form been filled out? Check for correct model and serial numbers from the nameplate, then mail the completed form to Scotsman.
12. Has the owner/user been given the name and telephone number of the authorized Scotsman Service Agency serving that location?
13. To start up machine, follow the directions on page 12. For more information on the unit, turn to the next page.

# SCE275

## Removal of the Cabinet

One of the most useful features of this ice machine is the ability to remove the cabinet from the ice machine without removing the ice machine from its installed position.

### To Remove:

To remove the cabinet base the hood must be removed first.

1. Remove 5 screws and the three grills at the front of the base.

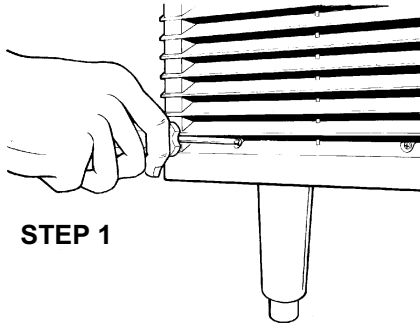

2. Push and hold the Off button the AutoIQ Controller until the machine has switched OFF. Be certain the ice machine has been switched off.

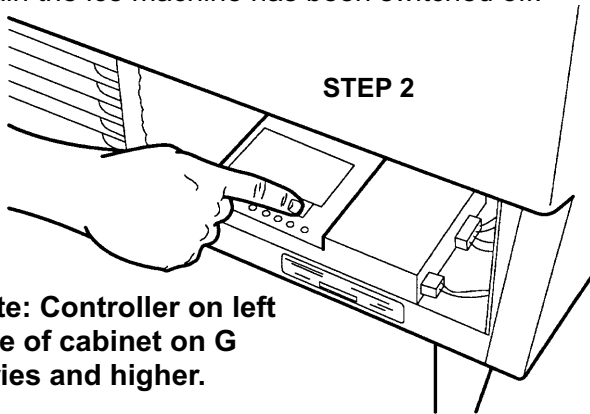

**Note: Controller on left side of cabinet on G series and higher.**

3. Open the bin door and unscrew the knobs at the left and right inside of the ice storage bin. Unscrew the knobs all the way out.

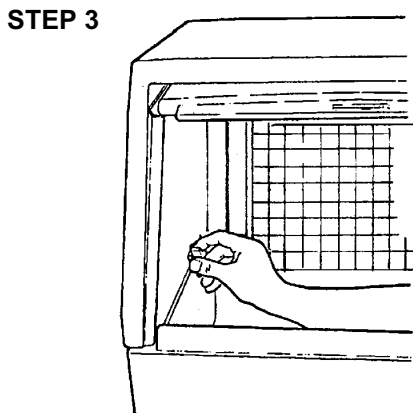

4. Pull the hood and door assembly straight out until it can be lifted up.

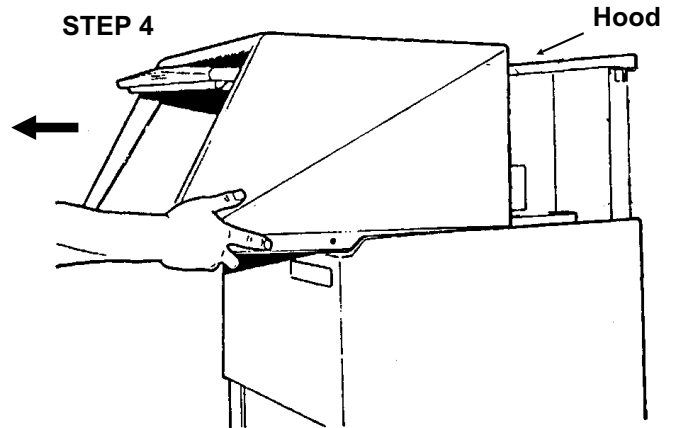

5. In the area behind the grills (removed in step 1) are two knobs similar to those removed in step 3.

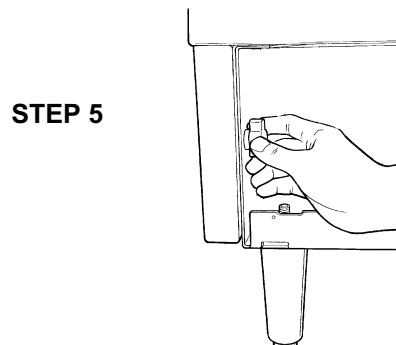

Unscrew and remove the two knobs.

6. Locate the bin drain. Loosen the hose clamp holding the drain tube to its fitting and pull the drain tube off of the fitting.

7. Lift up the front of the base and rotate the base up and off of the ice machine.

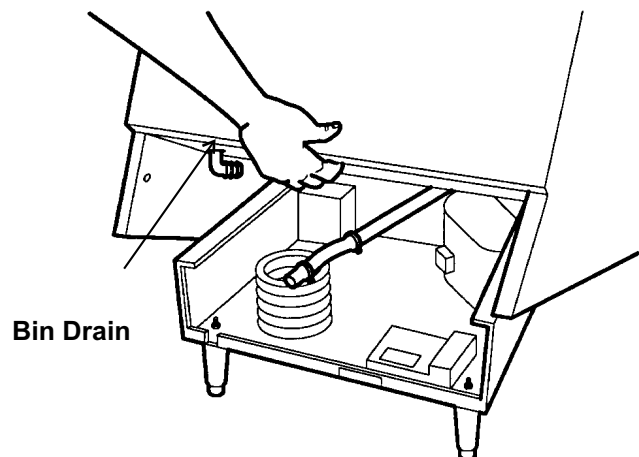

The machine is now exposed for service.



## Component Location

The ice machine is designed for front service. Many components are serviceable from the front without removing the cabinet. With the cabinet removed, nearly all components are serviceable.

When the bin is removed, the condensing unit is visible.

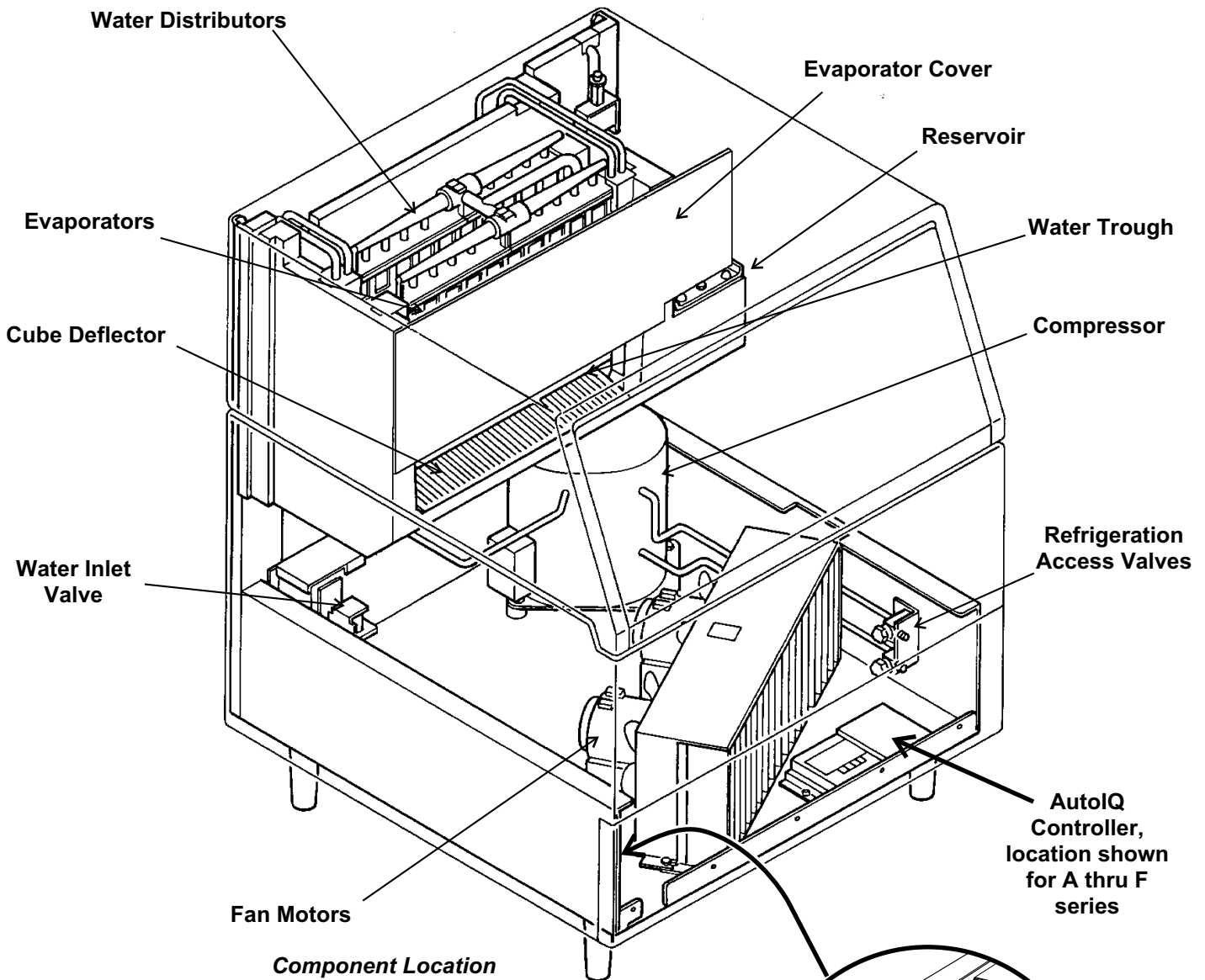

These parts are located inside the bin:

- Evaporators
- Water Reservoir
- Water Pump
- Cube Deflector
- Water Troughs
- Water Distributors
- Water Level Sensor

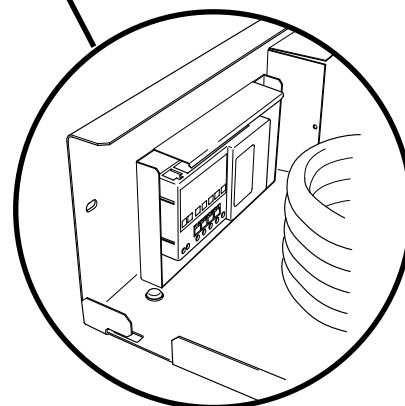

Controller Location, G series and higher

# SCE275

## Component Description

---

### **High Pressure Cut Out - Water Cooled Only**

This is a switch that opens to stop the ice machine when the internal refrigeration pressures become too high (over 450 PSIG). It is an automatic reset.

### **Evaporators**

Where the ice is formed. There are two vertical evaporator plates that form vertical strips of cubes. The strips break up into individual cubes as they fall.

### **Thermostatic Expansion Valve**

The thermostatic expansion valve is used to meter liquid refrigerant into the evaporator, adjusting the flow of refrigerant as required to make ice.

### **Reservoir:**

Contains the water used for ice.

### **Water Inlet Valve:**

Opens to allow water into the reservoir.

### **Water Level Sensor:**

Controls the size of the ice cube by measuring how much water is used in a cycle. It consists of a float, stem and electric eye. The stem will move slightly when the pump is on, this is normal. As the machine makes ice the reservoir water level will fall and the visible portion of the stem will slide down thru the slot in the sensor body.

### **AutoIQ Controller:**

Controls the operation of the ice machine. Turns it on and off; switches it between cycles; shows information via indicator lights; and shuts the machine down if there is a problem.

### **Evaporators/Freezing Compartment:**

Location of the 2 evaporators. Ice forms on the evaporators and is released when warmed up during the harvest cycle.

### **Cube Deflector:**

The slots in the inclined deflector let the water falling from the evaporators back into the reservoir, but when ice falls during harvest, the ice slides off into the bin.

### **Water Trough**

Diverts water from the evaporators to the right and left to keep water off the ice.

### **Refrigeration Service Access Valves:**

Only to be used by a certified technician. Allows access to the refrigeration system for diagnostic information.

### **Water Pump:**

Forces the water from the reservoir to the top of the evaporators. The motor is separated from the reservoir water to minimize contact with the water.

### **Compressor:**

The refrigerant vapor pump, it forces the refrigerant to flow thru the refrigeration system tubing.

### **Hot Gas Valve:**

Closed during freeze, it opens during harvest to divert hot discharge refrigerant gas into the inlet of the evaporators.

### **Condenser:**

Either air or water cooled, discharges the heat produced in ice making.

## AutoIQ Controller

### Indicator Lights:

**Bin Full:** On when bin is full, goes on and off as ice falls during a harvest cycle.

**Freeze:** On when the unit is in the Freeze cycle, blinks when a freeze mode is pending.

**Harvest:** On when the unit is in the Harvest cycle.

**Clean:** On when the unit is in the Clean cycle, blinks when preparing for a clean mode.

**Off:** On when the unit has been switched off, blinks when the machine is preparing to shut off.

**Water Error:** On when the controller has identified a problem with the water system.

**Refrigeration Error:** On when the controller has identified a problem with the refrigeration system.

### Cycle Definitions:

**Freeze:** The refrigeration system is operating to remove heat from the evaporators. The compressor, fan motor (if air cooled) and water pump are ON.

**Harvest:** The refrigeration and water systems are operating to harvest the ice cubes. While the compressor is on for the full cycle, the water pump will be off at the beginning and inlet water valve will switch off before the end.

**Clean:** The Inlet Water Valve opens to fill the reservoir. The Water Pump starts. The Clean indicator light is switched ON. A manually initiated rinse flushes the system.

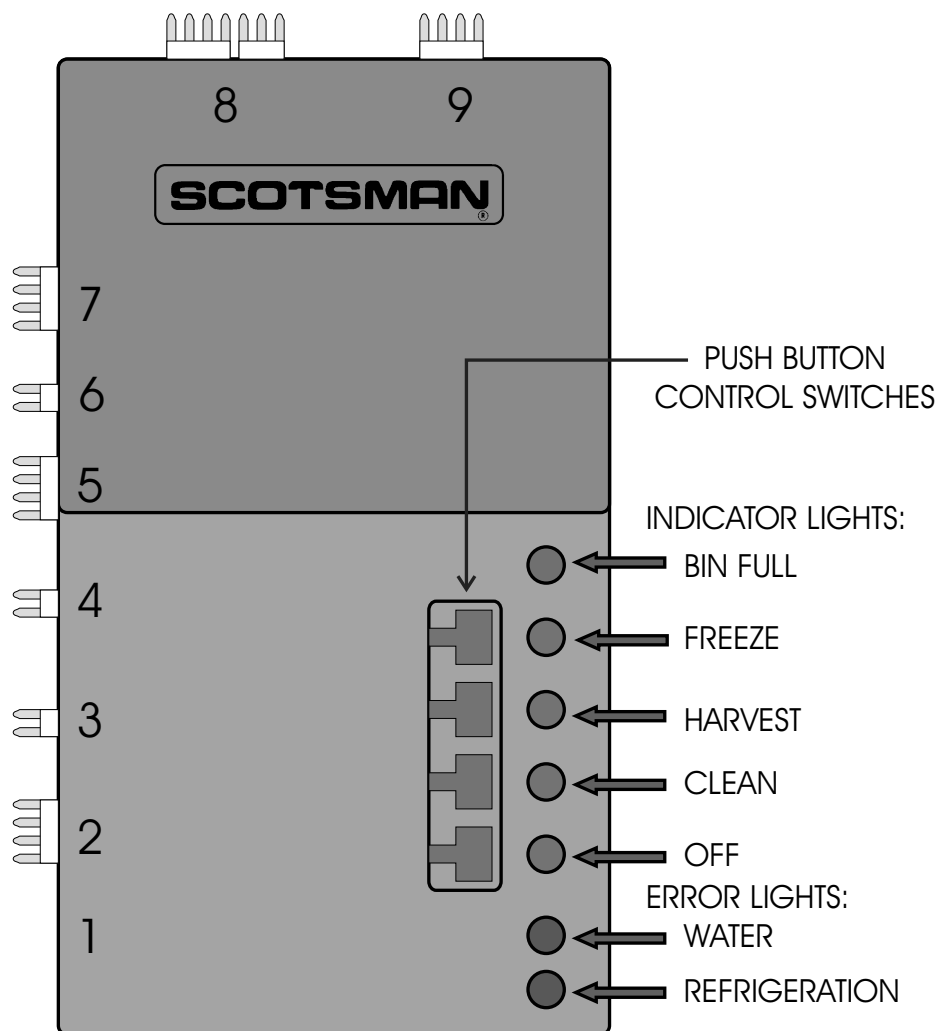

## Initial Start Up

---

1. Remove two screws and the left grill (G series and higher).
2. Locate the AutoIQ Controller - use a flashlight to see the buttons and lights.
3. Plug the machine in or switch on the electrical power. Note that the controller's indicator lights all flash on briefly when power is connected.
4. Open the water supply valve to the machine.
5. Push and release the Freeze cycle push button (the Freeze indicator light will blink until the compressor starts). The next several operations are automatic.

### **Initial Start (30 seconds)**

The Freeze light begins to blink.

The Hot Gas Solenoid valve will be open.

The inlet water valve opens to fill the reservoir and shuts off when the reservoir is full. Note: If the reservoir does not fill the next steps do not happen.

The water pump starts. Note: if the pump does not start the next steps do not happen.

The inlet water valve opens again to refill the reservoir.

After 30 seconds, the hot gas valve closes and the compressor starts.

### **Freeze Cycle:**

The Freeze indicator light will come on. The machine will stay in a Freeze cycle for many minutes. Slush may appear in the reservoir, it is temporary and normal.

Under certain conditions, the pump may stop for a few seconds. After that the inlet water valve will refill the reservoir.

The fan motors (of air cooled models) will begin to turn and soon warm air will be forced out the front of the cabinet. After 4 minutes the fan motors may cycle on and off every 30 seconds in cooler ambients.

As the freeze cycle progresses, the water level will fall and the inlet water valve will open to refill the reservoir. This will happen twice every cycle.

The freeze cycle will continue until the water level in the reservoir has fallen again to its factory set point, then the AutoIQ Controller may switch the air cooled fans off. After a short time, the Harvest Cycle will begin.

### **Harvest Cycle:**

The Harvest indicator light will be ON,

The hot gas valve will open.

The water pump will stop. It will restart in less than a minute.

The Inlet water valve will open. The machine will fill the reservoir and overflow it for a specified number of seconds then shut off. The harvest cycle may still be in progress.

The Bin Full indicator light will go on and off as ice falls from the evaporators.

6. Machines are shipped from the factory with the purge level set to accommodate average water conditions. To achieve optimal machine performance, set the purge level to the minimum setting.

Note: While the amount of water purge is adjustable, only those installations with a water supply known to be excellent (very low TDS or total dissolved solids) should adjust to the minimum setting. See page 14 for purge adjustment instructions.

7. Observe ice harvest. Check that the ice slides easily into the bin, and does not hang up on any mis-positioned part.

8. After about 5 minutes the machine will return to a freeze cycle.

**Note: The first 1-2 harvest cycles will be very long to establish a typical harvest time.**

9. Fill out the Customer Evaluation and Warranty Registration. Send it to Scotsman.

10. Replace the front grill.

11. Inform the user of the location and telephone number of the local service company. Also inform the user of the required maintenance of the machine.

## Notes On Operation

---

1. The electric eyes signal the ice machine to shut off whenever the bin becomes full. After the eyes sense that there is ice between them, the ice machine will shut off at the end of the next harvest cycle. This last harvest cycle will be longer than the rest, and will be for the Maximum Harvest Time.

Note: Ice will normally fill up to the bottom of the evaporators before the machine shuts off.

2. After the bin has filled the ice machine will not be able to restart for 4 minutes. However, if needed, the Freeze button may be pushed and the unit will restart.

For example: If ice is removed from the bin immediately after the machine has filled up and shut off, the machine will not restart for 4 minutes.

3. If the bin controls sense a bin full signal before any water is used (float stem up), the machine will shut off on bin full.

### **If there was a problem during Initial Start Up:**

If an error light came on, check the following.

#### 1. Water error.

A water error could have been determined by the AutoIQ Controller if the inlet water valve does not fill the reservoir, or if the water pump does not start and lower the water level.

#### 2. Refrigeration error.

A refrigeration error could have been determined by the AutoIQ Controller if the water temperature did not drop during the freeze cycle. The controller will next check the compressor discharge temperature. If the discharge temperature is too low, the refrigerant error light will be switched on, and the machine will Shut Down.

### **Resets:**

Note: The machine may be reset and restarted by pushing and releasing the Off push button switch, and then pushing and releasing the freeze push button switch.

**Water Cooled:** If the water to the water cooled condenser circuit is cut off during a freeze cycle, the high pressure cut out will stop the operation of the compressor. The control is an automatic reset, but if the water interruption is prolonged, the AutoIQ Controller will shut the machine down when maximum freeze time has been exceeded.

# SCE275

## Adjustments

---

### How to adjust the water cooled discharge pressure

Water cooled models use a water regulating valve to control how much cooling water flows thru the water cooled condenser. At the top of that valve, located in the bottom rear of the ice machine, is an adjustment stem.

To Adjust:

1. Attach a refrigeration manifold gage to the discharge access valve.
2. While the unit is in the freeze cycle, determine the discharge pressure, it should be about 245 PSIG.
3. If needed, rotate the adjustment stem to increase or decrease the pressure:
  - A. To increase discharge pressure (reduce water flow) rotate the stem counter-clockwise.
  - B. To decrease the discharge pressure (increase water flow) rotate the stem clockwise.

Remove the manifold when done. Note: The water outlet temperature should be between 100-110 when the valve is properly set.

### Thermostatic Expansion Valve:

The TXV is not adjustable, do not attempt to adjust it.

### How to Adjust the Amount of Water Purge

Adjustment is done by use of the control buttons on the AutoIQ Controller. Examine the next section to become familiar with the AutoIQ Controller before beginning.

1. If the machine is on, push and hold the OFF button for more than 3 seconds, then release it. This switches the machine Off.
2. Push and hold the OFF button for more than 3 seconds (until all LEDs flash on) then release it.
3. Examine the green LEDs. They should have all flashed once, then certain ones will have turned on to indicate which purge level the machine is set at. There are 5 levels of purge available:
  1. **Maximum Purge** is when All 5 lights are ON. Note: This setting may extend the harvest cycle and reduce capacity.
  2. **Heavy Purge** is when these 4 lights are ON: Freeze, Harvest, Clean, Off .
  3. **Standard Purge** (Factory setting) is when these 3 lights are ON: Harvest, Clean, Off .
  4. **Moderate Purge** is when these 2 lights are ON: Clean, Off .
  5. **Minimum Purge** is when this light is ON: Off

Adjust by pushing and releasing the Freeze button. Pushing and releasing the Freeze button increases the purge one level up to the maximum, then it goes to the minimum.

4. The machine will automatically restart after 60 seconds of no switch inputs, or restart the machine by pushing in and holding the Off button for more than 3 seconds, then releasing it. The unit will then be Off. From there the machine may be placed in a freeze cycle by pushing and releasing the Freeze button.

## How To Operate The AutoIQ Controller

The AutoIQ Controller is a microprocessor based device that receives input from several sources and switches various components on and off.

Its manual control is thru the use of the Push Button Control Switches

1. **Freeze Button.** Pushing and releasing this button starts or restarts the machine. The AutoIQ Controller remembers what cycle it was last in and returns to that cycle.

2. **Harvest Button:** Pushing and releasing this button will cause the machine to go directly to a Harvest Cycle. Can be done from Freeze or Off. The machine will switch Off at the end of the Harvest cycle.

3. **Clean Button:** Pushing and releasing this button will cause the machine to only power the water pump for circulation of ice machine cleaner. After the ice machine cleaner has circulated for about 10 minutes, a second push of this button will switch on the rinsing system to flush out the dissolved scale and ice machine cleaner.

4. **Off Button:** Pushing and releasing this button will switch the machine OFF at the end of the next cycle. If the button is pushed and HELD for more than 3 seconds, the unit will switch off immediately.

**To Reset:** First push and release the Off button, then push and release the Freeze button.

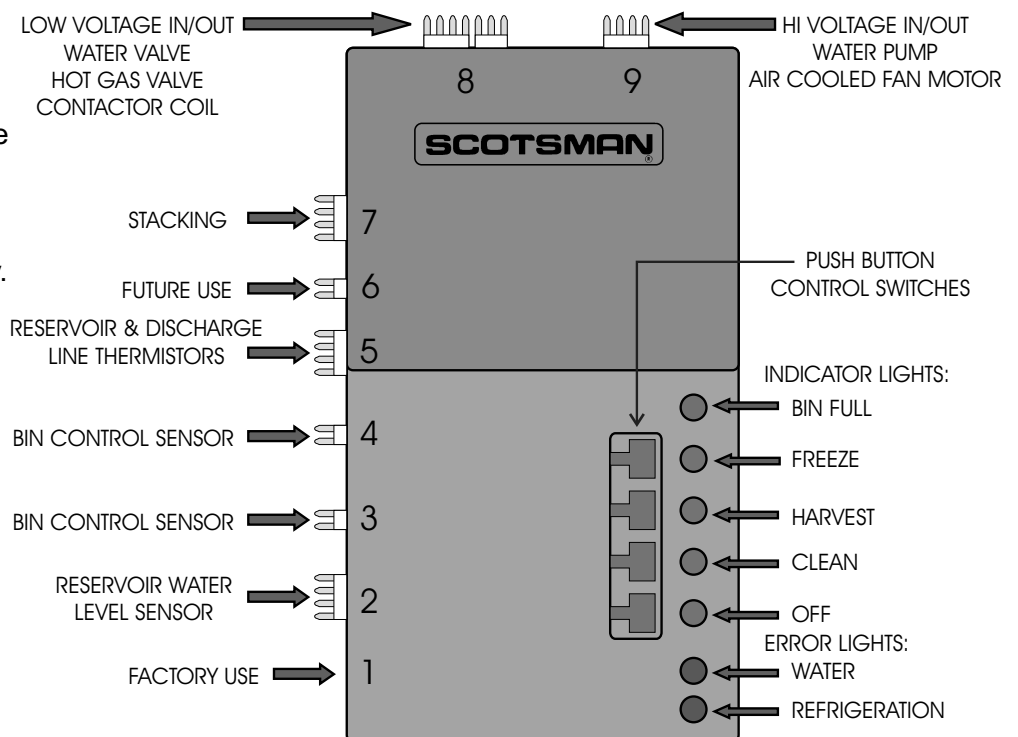

# SCE275

## How The Electronic Cuber Works

---

### Controller Inputs:

1. Reservoir water temperature. This is measured by a thermistor located in the water pump outlet.
2. Discharge line temperature. This is measured by a thermistor located on the compressor discharge line.
3. Water level. This is measured by an infrared sensor and float. The float rises and falls with the water level, and switches the sensor on and off as it moves.
4. Bin fill level. This is determined by a set of electric eyes between the evaporators. Ice eventually fills the bin and covers the cube deflector to the point that ice is between the bin controls (and the evaporators); after 20 seconds of "blockage" the bin controls signal the controller that no more ice is needed.

When ice is removed for use, the ice between the evaporators slides out into the bin and the ice machine automatically restarts.

Note: A few cubes may remain on the cube deflector, this is normal.

If little ice is used, the ice level will be high at the back of the bin. As ice is used, the ice will "level out" and fill the bin more evenly.

5. Time. The controller measures and compares how long it takes for various events to happen. It stores that data for future reference.

### Controller Outputs:

#### A. 24 volt:

1. LEDs
2. Inlet water valve
3. Hot Gas Valve
4. Contactor Coil

#### B. High Voltage

1. Water Pump
2. Air cooled Fan Motor

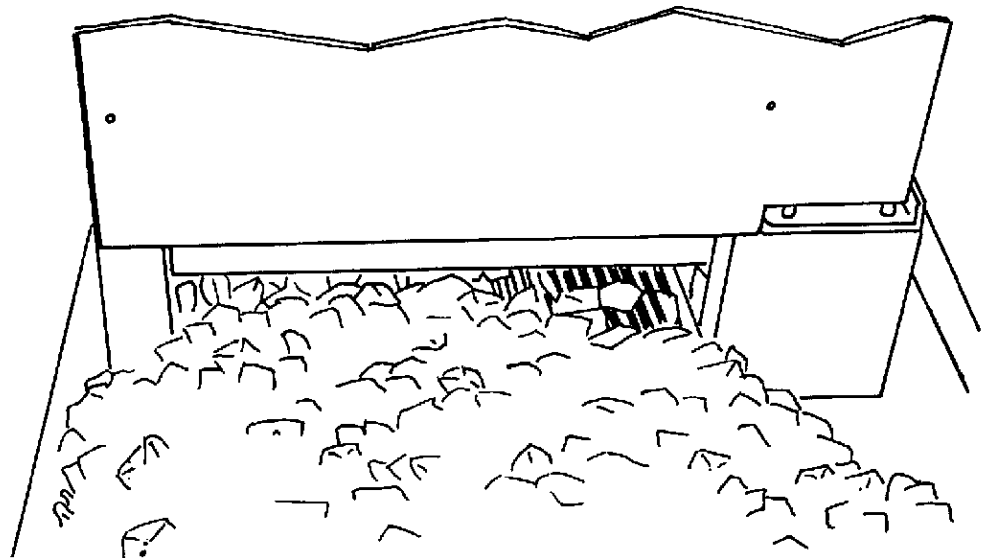

***When The Machines Fills Up To Its Shut Off Point, Ice Will Be On The Cube Deflector.***



# Water System

Water flows into the ice machine during the harvest cycle thru the inlet water valve. The water valve will NOT be open the complete length of the harvest cycle. The water pump forces water to the top of the evaporators, both in the Freeze and Harvest cycles. Un-frozen water falls thru the cube deflector and back into the reservoir.

As water is turned into ice, the water level in the reservoir falls to the full cube setting, and the Water Level Sensor sends a signal to the AutoIQ Controller to open the inlet water valve to refill the reservoir. This happens twice per freeze cycle.

The third time the water level falls to the full cube setting it indicates to the AutoIQ Controller that it is time to begin the Harvest cycle. The air cooled fans will shut off just before the beginning of the Harvest cycle.

During the Harvest cycle, water again enters the water reservoir, and overfills it to rinse the reservoir of accumulated minerals. It does NOT overflow for a fixed amount of time, but for a time determined by the AutoIQ Controller.

The water pump will be off for a short period of time at the beginning of harvest.

## Refrigeration System:

The refrigeration system is similar to that of most commercial cube ice machines. Heat is removed from the water and discharged out the condenser during the freeze cycle.

The evaporators are in series: As liquid refrigerant passes thru the Thermostatic Expansion Valve, it enters the bottom of the front evaporator, and ice will form there first. Refrigerant then flows out the top of the front evaporator and enters at the bottom of the back evaporator, finally flowing out the top row of the back evaporator and back to the compressor.

When cubes need to be released (Harvest) the Hot Gas Bypass Valve is opened and hot discharge gas flows directly from the compressor to the front evaporator inlet. This warms up the evaporators and the surface of the ice frozen to the evaporator surface melts. Ice then falls into the bin.

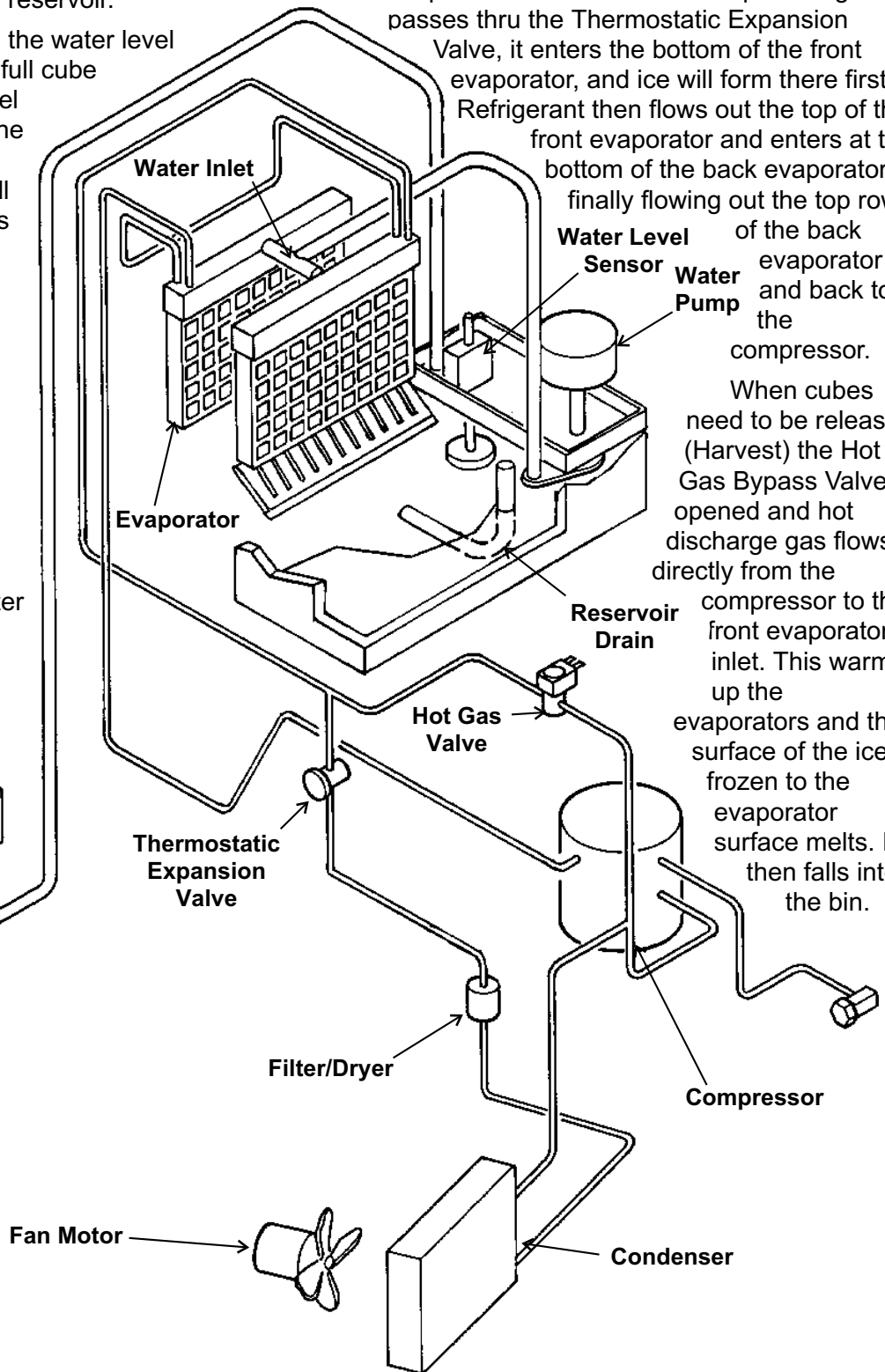

# SCE275

## Technicians Only: Freeze Cycle Operational Sequence

---

### How The Electronic Cuber Works

This section is intended for the technician. It is not necessary for the normal operation and maintenance of the machine.

The AutoIQ Controller operates the ice machine by monitoring several input measures and switching various loads on and off.

### **Assuming the machine has been operational, the Freeze cycle begins with the end of the Harvest Cycle:**

Reservoir is full

Condenser fan is OFF

Water Inlet Valve is OFF

Water Pump is ON

Compressor is ON

Hot Gas Valve is ON

### **AutoIQ Controller Operation, Beginning freeze:**

1. Switches on the Freeze indicator light and shuts off the hot gas valve.
2. Measures and stores the discharge temperature.
3. Starts the fan motors (air cooled only). Fan control begins 4 minutes into the freeze cycle. When the discharge temperature indicates that cooler ambient conditions exist, the fan is cycled on and off every 30 seconds until it is switched off just before harvest.  
If the discharge temperature exceeds the design maximum, shuts the machine down on a Refrigeration Error.
4. Checks for a "bin full" signal throughout the cycle.
5. Measures the reservoir water temperature. If the machine is operating correctly, the reservoir water temperature will fall at a standard rate. The AutoIQ Controller will be checking to see if the water temperature fall matches that rate.  
If not, it re-checks the discharge line temperature. If too low, it Shuts Down on a Refrigeration Error. If the discharge temperature is acceptable, the water system is checked by shutting off the water pump and determining if the water level goes up enough. If it does not, it is assumed that there is a water pump problem and the machine Shuts Down on a Water Error.

If the water level does "measure up" the water pump is restarted and the AutoIQ Controller then measures how long it takes to lower the water level. If the water level does not fall, the machine Shuts Down on a Water Error.

6. Once per cycle the machine may shut off the water pump. It only does this when the water temperature reaches a preset minimum. The pump will only be off for a few seconds. After the pump restarts, the inlet water valve opens to refill the reservoir.
7. When the water level falls to the pre-set limit, the inlet water valve will open to refill the reservoir. This happens **2 times** every freeze cycle.
8. As the machine makes ice, the water level in the reservoir will ultimately fall a third time to the Harvest Level (when the top electric eye in the water level sensor is disrupted by the adjustment screw). At that point, the fan may be shut off and the unit continues in a freeze cycle for a few more seconds (0-60 depending upon discharge temperature). Note: If the freeze cycle exceeds the preset Maximum of 35 minutes, the AutoIQ Controller will Shut Down on a Refrigeration Error.
9. The end of Freeze cycle will see the machine in this state:

Water level = below harvest position

Condenser fans will be off

Water inlet valve will be off

Water pump will be ON

Compressor will be ON

Hot gas valve will be off

At this point Harvest begins and the AutoIQ Controller switches the Harvest indicator light ON.

---

Note: If there is a power interruption, the AutoIQ Controller will automatically restart the machine with a process that begins with returning the machine back to a normal state: water re-fills the reservoir, the unit freezes for 30 seconds, and then goes thru a 4 minute harvest. After harvest it returns to a new Freeze cycle. While in this electrical restart mode, the controllers Freeze light will be blinking, even when it is in a Harvest cycle.

---

## Technicians Only: Harvest Cycle Operational Sequence

### Harvest

The (air cooled) fans are off.

The water valve opens and fills the reservoir to the Full level.

The water pump shuts off, it will restart in less than a minute.

The AutoIQ Controller checks how long it takes to fill the reservoir and if it was too much time, the machine Shuts Down on Water Error.

**Note: The machine will automatically attempt to restart after shutting down because of a lack of water. The time between restarts is about 20 minutes.**

The inlet water valve will stay on and open for a predetermined fraction of the time it took to fill the reservoir. This overflows and rinses the reservoir water.

During the Harvest Cycle, ice will be falling from the evaporators and between the bin control's electric eyes. The harvest cycle's length is based on the actual time from the start of the prior harvest cycle until the last cube fell, plus an added amount of time as a margin.

The maximum harvest cycle time allowed is 8 minutes. Harvest time is varied by the AutoIQ Controller based on the prior harvest cycle's length.

If no cubes fall (or are sensed) by the end of Maximum Harvest Time, the controller senses a refrigeration error. If the next cycle also produces a refrigeration error, the machine Shuts Down.

**Note: The last Harvest cycle before shutting off on Bin Full will be longer than normal (4-5 minutes).**

During a harvest cycle, the water pump will shut off when the bin sensors indicate that the bin is full.

Note: The machine will not restart for 4 minutes after switching off on Bin Full, unless the freeze button is pressed.

### Diagnostic Lights:

There are two diagnostic lights, one to indicate a water problem, and the other to indicate a refrigeration problem.

If a Diagnostic Light:	Water Light	Refrigeration Light
Blinks once and repeats	Water pump did not start	Very long ice harvest
Blinks twice and repeats	Lack of water fill	No harvest of ice
Blinks three times and repeats	not used	High discharge temperature
Is On all the time	Water valve leaking thru rapidly	Check for low discharge temperature or long freeze cycle
Both On all the time	Check for thermistor set unplugged or failed	

### Restarts:

The controller will attempt to restart the ice machine after the first and second shut downs because of a water or refrigeration error.

There will be a 50 minute interval between restarts.

There are two exceptions to this:

1. Lack of water. The controller will try to refill the reservoir about every 20 minutes after shutting down for lack of water.
2. Harvest errors: The controller must sense two consecutive harvest errors in order to stop the machine. The controller will try to operate the machine two additional times before a manual reset is needed.

# SCE275

## Sanitizing and Water System Cleaning

### Cleaning Schedule:

Scrub the door and frame edges once a week with soap and water.

Sanitize the bin interior once a month.

Clean the water system and air cooled condenser a minimum of twice per year. If in an area of high mineral concentration in the water supply, clean water system 4 times a year.

This ice machine will perform at its best when kept clean. There are three areas to keep clean: The water system including the water reservoir, distributors and evaporator surface; the bin controls; and the air cooled condenser filter and the condenser itself.

### Water cooled units:

The water cooled condenser may, over time and under certain water conditions, become internally restricted by minerals. These will have to be dissolved by acid or the condenser replaced. Only a qualified service agent should attempt this type of service.

### Air Filter (air cooled only):

The air filter is located in a slot between the condenser fins and the condenser fans.

1. Remove the grill on the left front of the unit.

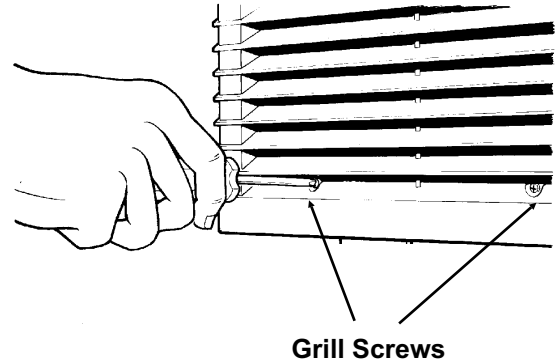

*Grill Removal*

2. Locate the filter edge, it is between the condenser fins and the fan motors.
3. Pull the filter to the left through the slot in the front base of the ice machine.

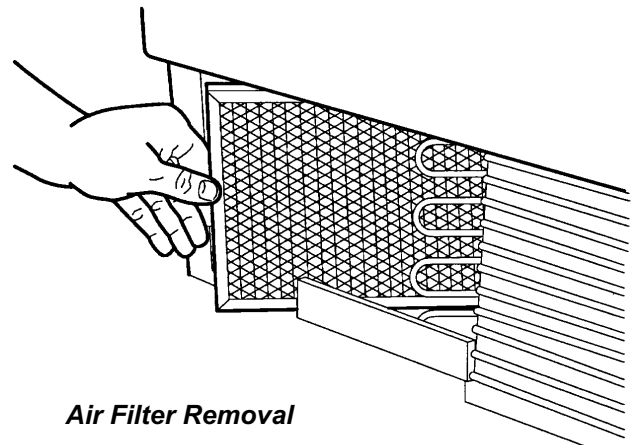

*Air Filter Removal*

4. Wash the surface of the filter off with cold water, or, if torn or so dirty it can't be cleaned, replace with a new filter.
5. Return the filter to its installed position.
6. Replace the grill. Do not operate the unit without the filter in place.

Note: If the unit has been operated without the filter in place, the fins of the condenser will become fouled with dirt, and must be cleaned.

If there is any doubt about dirt inside the fins of the condenser, the cabinet should be removed and a qualified service agent should clean the condenser.

## Sanitizing and Cleaning In Place Cleaning of the Ice Machine Water System:

1. Remove and discard all ice from the bin. If the cleaning was pre-planned, the ice machine could be switched off the night before to minimize waste.
2. Remove the left front grill.
3. Push and release the Harvest button (this releases any ice that may be on the evaporators and warms them up).
4. Wait for the machine finish the Harvest cycle the machine will switch off). The Off light will be blinking.
5. Push and release the Clean button. The Clean indicator light will be blinking and the pump will re-start.
6. Pour 8 ounces (235 ml) of Scotsman Ice Machine Cleaner into the reservoir water (below the evaporators).
7. After the ice machine cleaner has circulated for 10 minutes, push and release the Clean button.

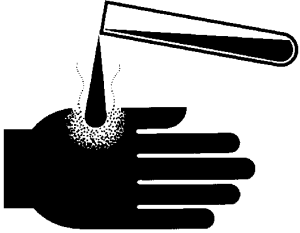
<p><b>Ice Machine Cleaner contains acids. These compounds may cause burns.</b></p> <p>If swallowed, DO NOT induce vomiting. Give large amounts of water or milk. Call Physician immediately. In case of external contact, flush with water.</p> <p><b>KEEP OUT OF THE REACH OF CHILDREN.</b></p>	 
--	---

***Pouring Ice Machine Cleaner into the Reservoir***

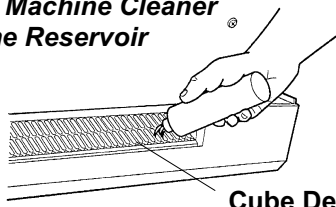

This starts the rinse process. The Clean indicator light will be ON. Note: The rinse flushes any residual cleaner out of the ice machine's water system.

8. Continue the rinsing process for 20 minutes, then push the off button to switch the machine off. Go thru steps 9-23 to sanitize the ice machine water system or go to step 24 to finish the cleaning process.
9. Mix 2 gallons of Sanitizer solution. Follow local codes for Sanitizer.

Note: A possible sanitizing solution may be made by mixing 1 ounce of liquid household bleach with 2 gallons of warm (95-115° F.) potable water.

10. Locate the two three-prong-head bolts holding the hood to the bin and remove them.
11. Remove the hood from the ice machine.
12. Locate the evaporator cover and remove the four thumb screws that hold it to the machine. Remove the evaporator cover.
13. With rubber gloves and a clean cloth or spray bottle, use the sanitizer solution to thoroughly wash or spray all interior surfaces of the ice storage bin, hood, knobs, and bin door with the sanitizing solution. Wash the joint between the hood and bin with the sanitizing solution. Also wash or spray the evaporator cover, the inside back wall of the freezing compartment, the top of the water distributors, the exterior surface of the reservoir, and the troughs with the sanitizing solution.
14. Return the evaporator cover to its original position and secure it with the original thumb screws.
15. Return the hood to its normal position and secure it to the machine with the original bolts.
16. Pull cube deflector out of the reservoir.
17. Push and release the Clean button again.
18. Pour 11 ml or 2.25 teaspoons of liquid household bleach, or an amount of locally approved sanitizer of sufficient strength to create a sanitizing solution equal to 200 ppm of sodium hypochlorite in .75 gallons (2.8 l), into the reservoir water.
19. Thoroughly immerse the cube deflector in a container of sanitizing solution.
20. After the sanitizing solution has circulated for 10 minutes, push and release the Clean button. This starts the rinse process.
21. Continue the rinsing process for 20 minutes then push the off button to switch the machine off.
22. Repeat steps 10-15.
23. Return the cube deflector to its original position.
24. Push and release the Freeze button.
25. Return the front grills to their normal positions and secure to the machine with the original screws.

# SCE275

## Additional Maintenance

### Water Distributors

It may become necessary to remove the water distributors from the top of the evaporator and clean (de-mineralize) them outside of the ice machine.

1. Remove right front grill.
2. Push and release the OFF button.
3. Remove the machine's hood & door.
4. Reach over the water distributors and pull the hose off.
5. Push the two water distributors to the right until the left end clears its retaining slot, then pull the left end up.
6. Repeat for the back one.
7. Examine the top of the evaporators. The Water Distribution Channels must be free from mineral build up. If build up is evident, scrub the channels with Scotsman Ice Machine Cleaner and a plastic bristle brush.
8. Examine the water distributors. Although they are made of a material that is resistant to mineral build up, some may be present. Soak or scrub the distributors in or with a solution of Scotsman Ice Machine Cleaner and warm potable water.
9. Return the water distributors to their normal installed position.
  - 9a. Snap the two distributors onto the water manifold. Place them on the back evaporator, right end first. Push the distributors far enough to the right until the left end clears the retaining slot, then release. Check that the distributors are seated properly.
  - 9b. Place the water hose onto the back water distributors.
  - 9c. Repeat for the front evaporator.
10. Reverse the above steps to reassemble.

The storage bin must be cleaned regularly to maintain a sanitary environment. Once a week cleaning of the door and door frame with soap and water, a hot water rinse and an air dry is a basic procedure. Scale that may form on the plastic liner can be removed by scrubbing the surface with a mixture of Scotsman Ice Machine Cleaner and hot water. Remove any scale prior to cleaning.

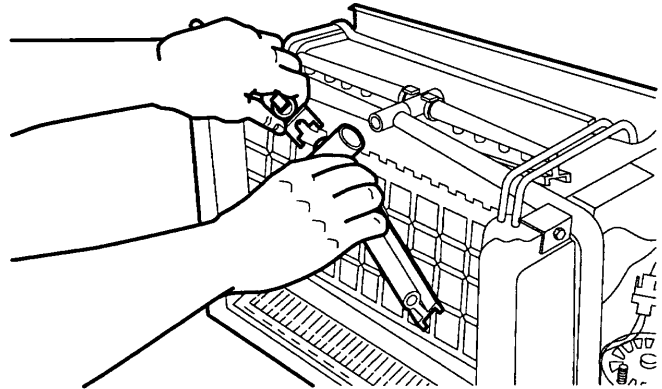

**Removal of Water Distributors**

### To Remove Scale From Bin Interior:

1. Mix a cleaning solution of 4 ounces of Ice Machine Cleaner to 4 pints of hot (95<sup>0</sup>F.-110<sup>0</sup>F.) water.
2. Using rubber gloves, dip a nylon scouring pad into the cleaning solution and scrub the scale off the interior of the bin.
3. After the scale has been removed, rinse all surfaces inside the bin with clean, potable water.

### To Drain Reservoir Completely (if desired):

1. Remove front panel.
2. Push and hold the Off button.
3. Remove screw holding reservoir cover, pull inlet tube out of reservoir cover, lift cover out of machine.
4. Unplug water pump connection, remove ground screw.
5. Remove float from float stem.
6. Unplug water level sensor.
7. Lift pump and sensor out of the machine.
8. Pull up on standpipe to release water.
9. Reverse steps 2-8 to reassemble.

Note: Be certain that the float is fully re-seated on the stem and the water pump bracket is positioned properly on the base.

Make sure that the stand pipe is properly seated.

10. Push and release Freeze button.
11. Replace front panel.

## Additional Maintenance

### Exterior Cabinet Cleaning:

The exterior cabinet may be cleaned by scrubbing with soap and water. Do not use cleaners containing petroleum products.

A nylon type brush may be used to scrub stubborn deposits.

### Additional Maintenance: Inlet Water Valve Screen

The inlet water valve has a screen on its inlet side to keep debris from flowing into the valve. In some cases, this screen may become clogged or restricted by debris build up. Check for the proper water flow:

Flow rate is 1.25 G.P.M.

1. Remove hood.
2. Remove right front grill.
3. Obtain a measuring cup and a watch.
4. Pull the water discharge tube out of the reservoir and place it in the cup.
5. Push and release the Harvest button.
6. If working properly, the water valve will fill an 8 oz cup in about 3-4 seconds. Be prepared to push the Off button. If it does not, the water valve inlet or other water device is restricted.

### To Check the Inlet Water Valve Screen.

1. Disconnect the electrical power.
2. Shut off the water supply.
3. Remove the hood and bin.
4. Unplug the electrical connection of the inlet water valve.
5. Remove the screws holding the inlet water valve to the cabinet.

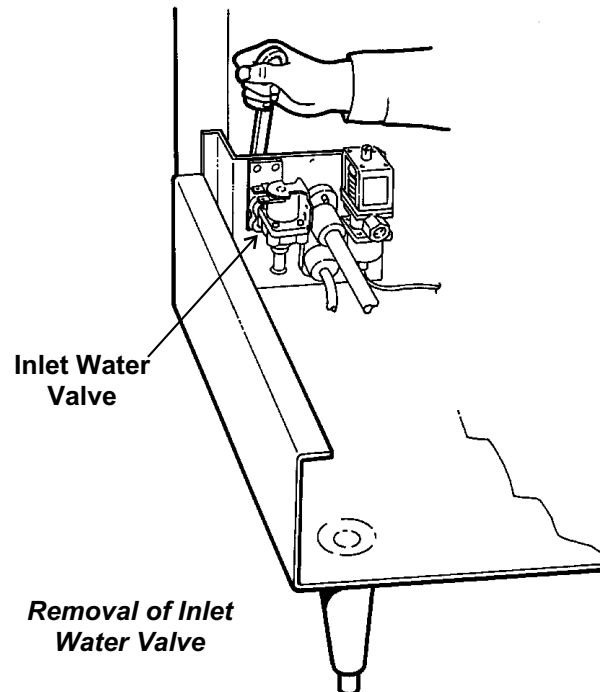

6. Remove outlet tube from inlet water valve.
7. Rotate inlet water valve from inlet fitting and remove valve from machine.
8. Examine the inlet screen, if dirty, brush off screen.

Note: Screen is not replaceable, and may only be removed by taking off the covering bracket. The bracket forms part of the inlet water system, and must be water tight to the valve body, removal is not recommended.

9. Reverse to reassemble.

# SCE275

## Additional Maintenance: Bin Controls

The bin controls use a system of infrared emitting and receiving components to sense the build up of ice in the bin. They are located in between the evaporators. They must be free of mineral build up to function properly. To check:

1. Remove the right front grill.
2. Push and hold the off button until the machine stops..
3. Remove the knobs holding the hood to the bin.
4. Remove the hood..
5. Remove the thumb screws holding the bin control brackets.

7. Examine the bottom of the brackets, there are two sensors in each bracket, check that they are clear of mineral build up. They may be wiped clean with ice machine cleaner to assist in removal of the build up. Use a toothbrush if necessary to remove scale.

Be sure to drain the reservoir or go thru a Clean cycle to remove residual cleaner.

Note: Do NOT use abrasive materials or cleaner on the bin sensor lenses.

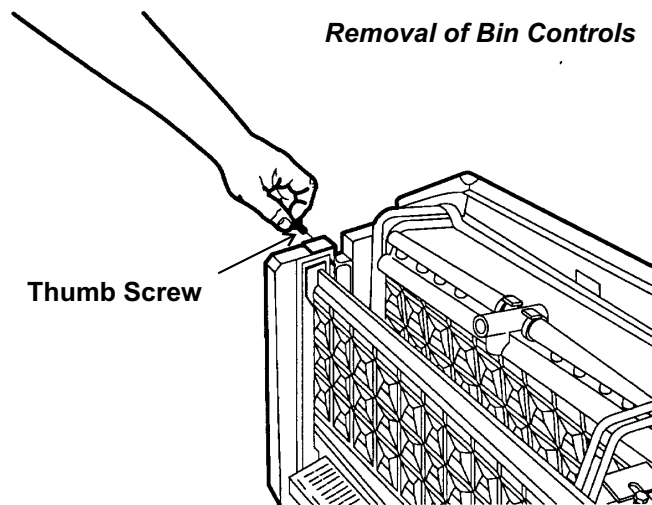

6. Lift the the bin control brackets up and out from between the evaporators.

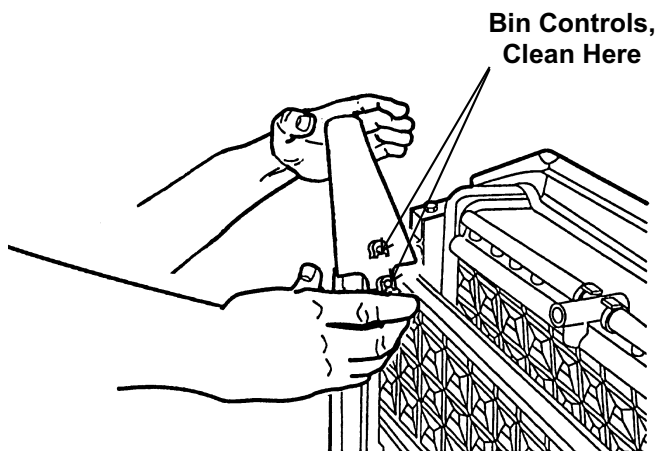



**Technical Characteristics**

Air Cooled	70°F. air and 50°F. water	90°F. air and 70°F. water
Typical Freeze Cycle Time	15 minutes	18 minutes
Typical Harvest Cycle Time	2 minutes	1.5 minutes
Typical Low Side Pressure, end of freeze	24 PSIG	29 PSIG
Typical Discharge Pressure, end of Freeze	235 PSIG	306 PSIG
Typical Low Side Pressure, peak in Harvest	130 PSIG	118 PSIG
Typical Discharge pressure in harvest	270 PSIG	240 PSIG

Water Cooled	70°F. air and 50°F. water	90°F. air and 70°F. water
Typical Freeze Cycle Time	15 minutes	16 minutes
Typical Harvest Cycle Time	2.5 minutes	2 minutes
Typical Low Side Pressure, end of freeze	24 PSIG	26 PSIG
Typical Discharge Pressure, end of Freeze	245 PSIG	245 PSIG
Typical Low Side Pressure, peak in Harvest	90 PSIG	93 PSIG
Typical Discharge pressure in harvest	175 PSIG	190 PSIG

**Typical Harvest Ice Weight**

2.8 to 3.2 lb.

**Refrigerant Type / Charge**

R-404A / 18 ounces air cooled

R-404A / 12 ounces water cooled.

**Hi Pressure Cut Out - Automatic Reset (water cooled only)**

400 PSIG Cut Out + or - 10 PSIG

300 PSIG Cut In + or - 10 PSIG

**Typical Compressor Amp Draw**

Freeze: begins at 6.9 declines to 4.1

Harvest: 7 - 7.3

**Superheat**

4-6° F. 10 minutes into freeze cycle. TXV is not adjustable.

**Compressor**

Tecumseh hermetic, capacitor start, capacitor run (A series).

# SCE275

## Service Diagnosis

Proper service diagnosis begins with observation, comparing the complaint to the operation of the unit. Ice machine service diagnosis should proceed from water, to electrical and then to refrigeration.

Problem or Symptom	Possible Cause	Probable Correction
Machine is off	Bin is full, ice in cube port	Use some ice
	Power is off, check LEDs.	If all lights are out, check power supply, restore power if off
	Transformer is open	If all lights are out and there is power, check transformer output for 24 vac
	Unit has been switched off or has finished a Clean cycle, Off Light is glowing	Push and release Freeze button
	Unit has Shut Down	Check for Refrigeration or Water Error
Unit is off on a Water Error	Water inlet valve malfunction	Check water Light, if the Light blinks 2 times and repeats, check the water inlet valve for proper water flow.**
	Water pump malfunction	Check that pump hose is attached and if pump is plugged in and working.
	Water level sensor may have failed.	Check float stem, reset machine. If it will not reset or gives another water error and everything else is OK, replace the water level sensor.
Unit is off on a Refrigeration Error	Low discharge or long freeze cycle	Check refrigeration Light. If the Light is glowing, there is a probable refrigeration problem or on water cooled a water interruption
	Harvest problem	Check refrigeration Light. If the Light blinks once and repeats, look for a harvest problem.** This also indicates that cubes were sensed by the bin controls.
		If the light blinks 2 times and repeats, check for a harvest error - no cubes sensed.
	High Discharge Temp	Check refrigeration Light. If the Light blinks 3 times and then repeats, check for a reason for high discharge temperatures - such as a bad fan motor or very hot ambient.
	Unit does not go into harvest - exceeds maximum freeze time	Push and release Off button. Push and release Freeze button. Check operation.
Push cube size float down and check operation.		
Unit runs and both Error Lights are ON	Temperature sensors out of range	Replace the temperature sensor set (water and discharge).
Same, but 1 light is on	Reservoir temp. wrong	Check water temp and sensor.

\* Machine may be reset by pushing and releasing the Off button, then pushing and releasing the Freeze button. \*\* See following pages

## Service Diagnosis

Problem or Symptom	Possible Cause	Probable Correction
Unit is off because of a "Harvest Problem"	Bin controls did not sense ice falling, unit stayed in harvest until the maximum harvest time ran out.	Check bin controls. The bin full light should be off. If it is on or blinking the bin controls may be dirty. Clean if dirty. The board and bin controls may also need to be checked. Push and release Off button. Push and release Freeze button. Check machine operation. Check if ice is made and harvests.
	Bin controls or AutoIQ Controller may have failed.	See "Unit does not shut off" below..
	Other components may have failed	Check the next page
Cubes are too large	Cube size control float is sticking.	Check/clean
	Inlet water valve leaks thru	Check inlet water valve
Cubes are too small	Unit not level	Check levelness
	Not enough water	Check for leak in reservoir
Low ice capacity	Dirty condenser or filter	Replace filters, clean condenser
	Blockage of air flow	Remove anything from in front of the machine that blocks the free flow of air.
	Low refrigerant charge	Check system. If there is a low charge, find the leak, recover the refrigerant, repair the leak, replace the dryer, evacuate and weigh in the nameplate charge.
Unit does not shut off	Bin control system may have failed.	Check bin controls. Check bin full light, if off, place something between the electric eyes. <u>Note: Hood must be on. Use a piece of duct tape about 4" long and position it by hand between the evaporators.</u> The bin full light should begin to blink (after 20 seconds of continuous blockage it will glow steadily). If not, check operation of electric eyes by unplugging #4 and jumping out the two pins on the controller. If the bin full light blinks, replace the bin controls. If it does not blink, replace the controller. Note: Leaving #4 unplugged and jumped for 20 seconds will shut the machine down on a bin full. It will restart after 5 minutes or may be reset by pushing the Freeze button.

# SCE275

## Service Diagnosis

Problem or Symptom	Possible Cause	Probable Correction
Fan motor(s) do not turn.	Open motor windings, or seized bearings, or blade stuck against shroud	Replace fan motor or free fan blade.
	No power to fan motors	Fan motor unplugged, check for voltage at controller. Controller cycles fan motors during freeze. If no voltage to the fan motors at controller during freeze, replace controller.
Pump motor does not turn	Open motor windings, or seized bearings	Replace pump
	No power to pump	Check electrical connections. Check water level. Switch the unit to Clean, the pump should then have power to it. If not, replace the AutoIQ Controller.
Hot Gas Valve does not open.	Open solenoid coil.	Replace hot gas valve
	Stuck valve	Replace hot gas valve
	No power to coil in Harvest	Check wire connections, if ok, replace AutoIQ Controller
Hot Gas Valve leaks thru (warm tube temperatures on both sides of valve during freeze)	Mechanical problem in valve	Replace valve
Water Inlet Valve does not open	Open solenoid coil	Replace valve
	Stuck valve	Replace valve
	No power to valve (early part of harvest)	Check wire connections, if ok, replace AutoIQ Controller
Water Inlet Valve does not flow enough water	Restriction in water supply	Check water filters and/or inlet screen.
Water Inlet Valve leaks thru	Mechanical problem in valve	Replace valve
Compressor does not work	Unit in Clean cycle	Push and release Freeze button.
	Contactors coil open	Replace contactor
	Open starting components	Check and replace
	Open windings	Check and replace compressor
	Internal valve failure	Replace compressor

## PTCR

---

The “D” series and higher use a PTCR (Positive Temperature Coefficient Resistor) in place of a conventional start relay and start capacitor.

Power from the contactor connects to the PTCR and to the Run Capacitor

A wire connects the other terminal of the PTCR to the compressor’s start winding.

Another wire connects the run capacitor to the start winding.

A parallel circuit connects power from the contactor to the Run winding of the compressor.

A PTCR changes resistance sharply when its temperature changes. When the PTCR is cold, it connects full current to the compressor’s start winding. After a very short time, the PTCR heats up and shuts off the current flow. Under normal conditions, the PTCR’s case is at about 180°F.

At that temperature the PTCR has very high resistance and will not allow current to flow. It must cool down to about 120°F. Before current will pas through it again.

Diagnosis:

1. Disconnect electrical power.
2. Check if the PTCR is cool enough to handle safely. If not, wait 5 minutes for it to cool off.
3. Disconnect both leads to the PTCR and measure its resistance with an ohmmeter. If the PTCR reads less than 22 ohms or more than 40 ohms, replace it.

# SCE275

## Removal and Replacement: AutoIQ Controller

---

Begin by disconnecting the electrical power.

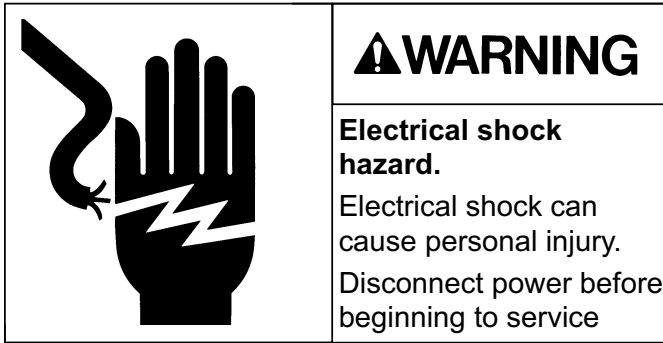

1. Remove 2 screws and the right front grill.
2. If the machine is operating, push and hold the Off button until the machine switches off.
3. Unplug or disconnect electrical power.
4. Remove the one screw at the right end of the AutoIQ Controller.
5. Pivot the controller up and away from its mounting bracket.
6. Unplug all connecting wires.
7. Reverse steps 6-1 to replace the controller.

### Electrical Box and Components

Below the bin on the left side of the chassis is a sheet metal box containing the transformer, compressor contactor, compressor relay, start capacitor and run capacitor.

This box may only be accessed by removing the hood and bin. After that:

1. Remove the cap screw securing the electrical box to the ice machine chassis.
2. Pull the electrical box forward to release it from the tab at the back of the box.
3. The box may now be placed in a horizontal position for better service access.

### Standpipe:

The overflow standpipe is located at the back of the reservoir. The water pump and water level sensor must be removed to get access to it.

The height of the standpipe is very important. Measured from the top edge of the reservoir to the very top of the standpipe, the distance should be:

3 <sup>27</sup>/<sub>32</sub> "

## Removal and Replacement: Water Pump, Water Level Sensor

### Water Pump

The pump provides the force to move the water from the reservoir to the freezing surface. The pump does not need oil, but if it becomes noisy, overheats, or will not pump it should be replaced. Be certain to confirm electrical faults with a voltmeter or ohmmeter before replacing the pump. The pump should operate with the compressor.

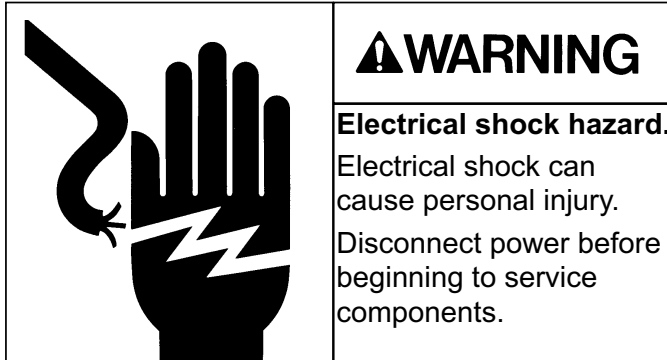

1. Unplug or disconnect the electrical power.
2. Open the bin door and unscrew the knobs holding the hood to the bin.
3. Pull the hood off the bin.
4. Remove ground wire from mounting screw.
5. Unplug water pump.
6. Unplug water level sensor.
7. Remove the 2 screws holding the reservoir covers to the reservoir.
8. Pull the water pump and water level sensor assembly up and out of the reservoir.
9. Remove the screws holding the water pump to the two reservoir covers, and the pump is free to be replaced.
10. Reverse steps 9-1 to replace the pump.

### Water Level Sensor

1. Unplug or disconnect the electrical power.
2. Open the bin door and unscrew the knobs holding the hood to the bin.
3. Pull the hood off the bin.
4. Remove ground wire from mounting screw.
5. Unplug water pump.
6. Unplug water level sensor.
7. Remove the 2 screws holding the reservoir covers to the reservoir.
8. Pull the water pump and water level sensor assembly up and out of the reservoir.
10. Pull the float from the float stem.
11. From below the reservoir cover, push the mounting tabs together to release the water level sensor from the reservoir cover.
12. Reverse steps 11-1 to replace the water level sensor.

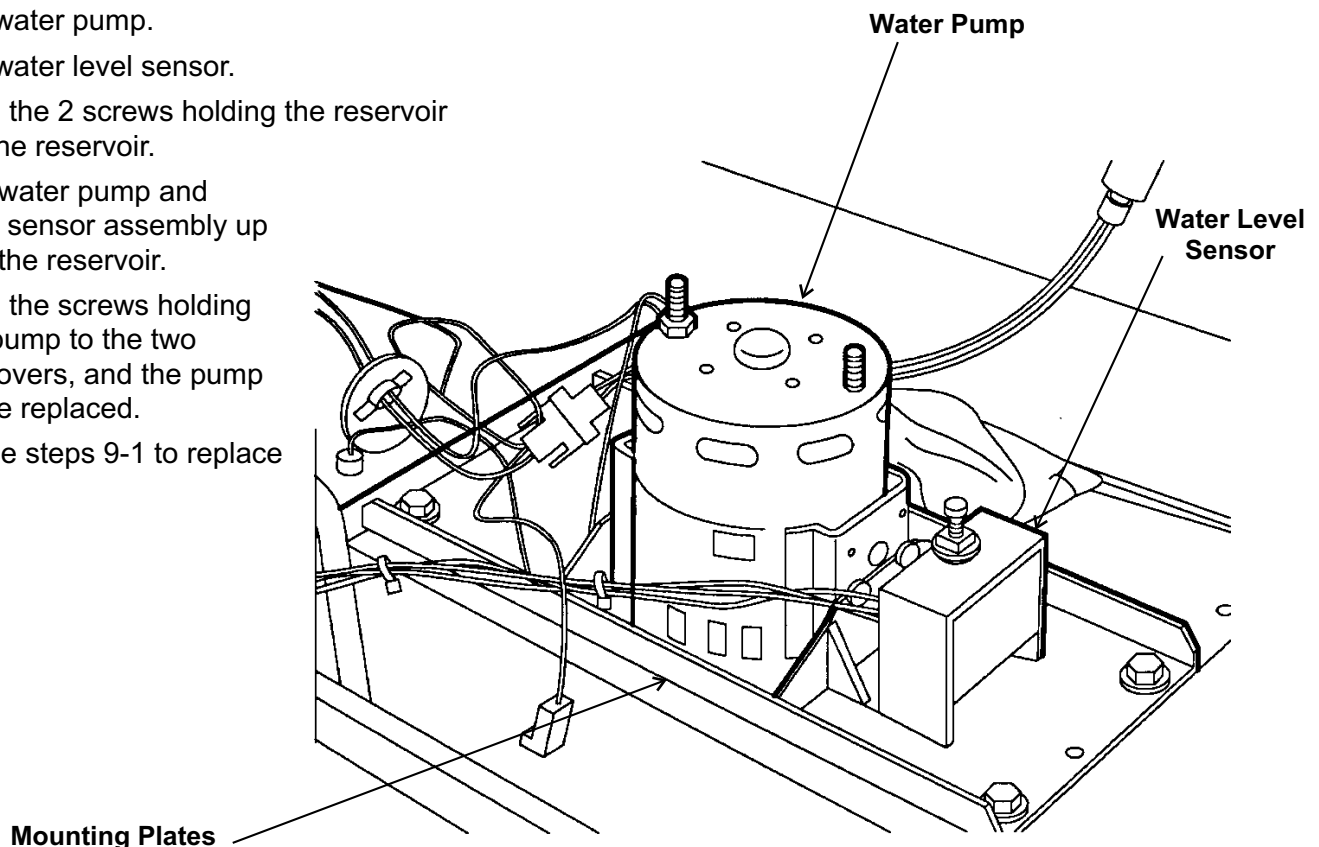

# SCE275

## Removal and Replacement: Inlet Valve & Water Trough

---

### Water Inlet Valve

The water inlet valve is located in the lower back of the cabinet. The hood and bin must be removed to gain access to this part.

The valve is directly connected to the incoming water supply. With the water supply turned off, the connection can be removed from the front of the machine.

1. Go thru the steps on page to remove the hood and bin.
2. Locate the inlet water valve. Pull the wire harness off the terminals of the valve.
3. Remove the cover over the utility connections.
4. Use two wrenches and loosen the nut on the male flare holding the water supply to the water inlet connection. Remove the water supply line from the water inlet valve.
5. Remove the two screws that hold the water inlet valve to the cabinet.
6. Pull the water inlet valve out and remove the discharge hose from the outlet of the valve.
7. The valve may now be removed from the ice machine.
8. Reverse steps 7-1 to replace the valve.

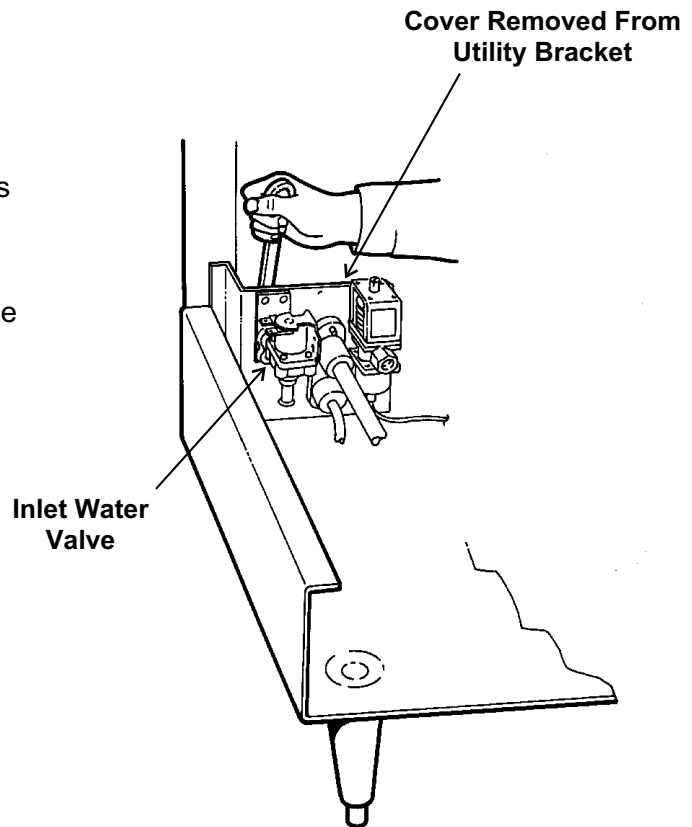

*View of Machine Without Bin or Hood*

### Water Trough

1. See the next page and remove the bin controls first (steps 1-9).
2. Pull out the cube deflector.
3. Unsnap the trough from the evaporator pins and rotate the front trough out of the machine.
4. Unsnap the trough from the evaporator pins and rotate the back trough out of the machine.
5. Reverse to reassemble. Note: The troughs are marked: **FRONT TROUGH** and **BACK TROUGH**. Begin by hanging the troughs on the evaporator's front pins and then rotating the trough until it snaps onto the back set of pins. Be certain that all 4 pins are engaged on each trough.



## Removal and Replacement: Bin Control Set

### Bin Controls

The bin controls are located in between the two evaporators, one on the left and one on the right. The hood must be removed to gain access to them.

1. Remove the right front grill.
2. If the machine is making ice, push and release the Harvest button.
3. After the ice has fallen off the evaporators, push and hold the Off button until the machine stops.
4. Unplug the machine or disconnect the electrical power.
5. Remove the two knobs holding the hood to the bin.
6. Slide the bin forward to remove it from the ice machine.
7. Locate the bin controls and brackets.

8. Remove the thumb screws holding the bin controls to the evaporators.

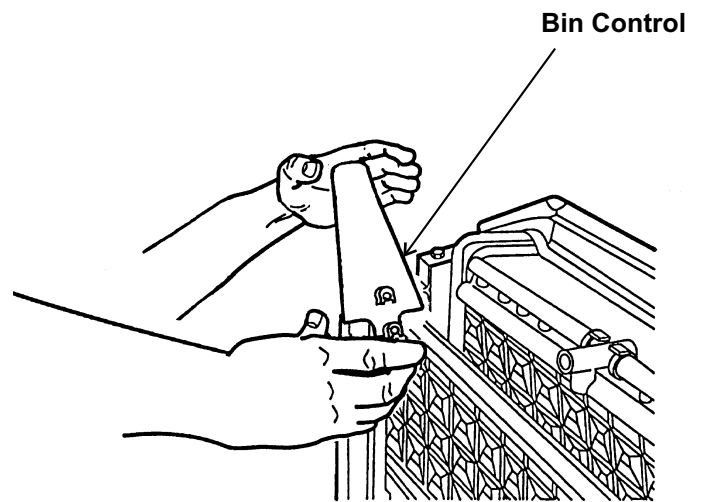

*Bin Controls May Have a Shield Over Them*

### Remove Mounting Bolt

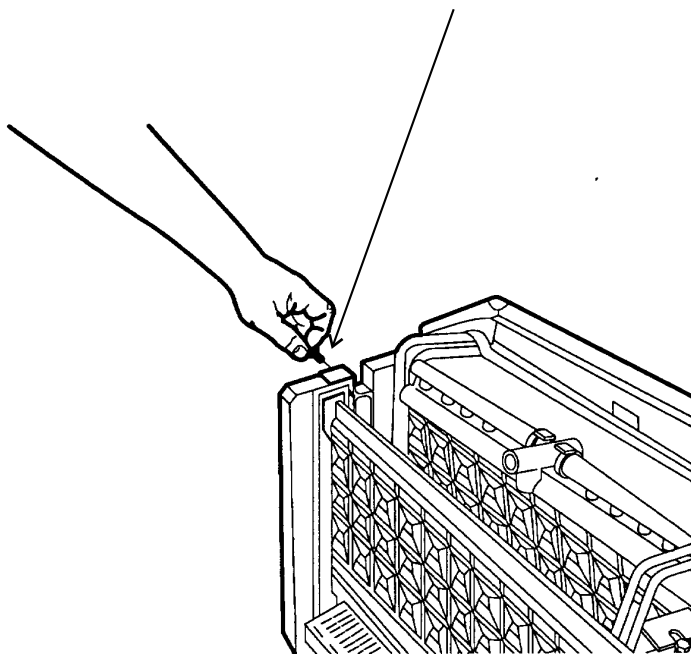

**Remove the Mounting Bolt First**

9. Pull the bin controls up and out of the ice machine.
10. Trace the wires back to the connectors, and unplug them.
11. Reverse steps 10-1 to replace the bin controls.

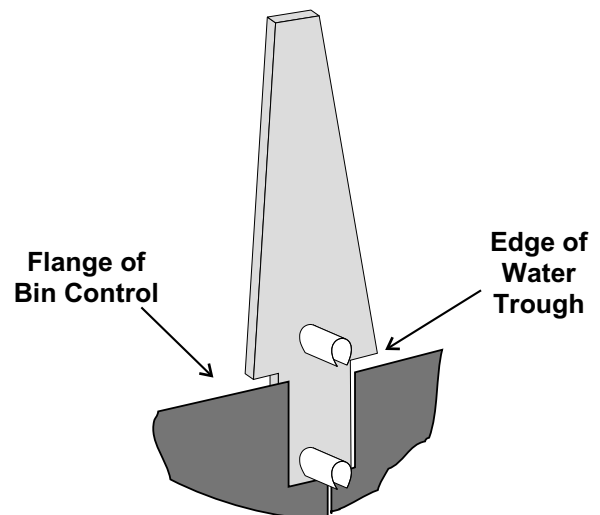

Note: They **MUST** be changed as a set.

The bin controls must be positioned so that the flange of the bin control is behind the water trough.

# SCE275

## Removal and Replacement: Thermistors

---

There is a thermistor to sense reservoir water temperature and another to sense compressor discharge temperatures. If the AutoIQ Controller senses a fault with the thermistors, both diagnostic indicator lights will be glowing continuously.

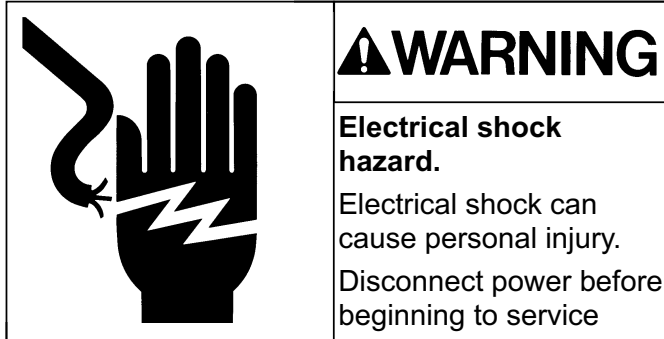

14. Insert the new thermistor into the discharge hose. Do not allow the body of the thermistor to contact the hose opposite of the mounting hole.
15. Secure thermistor with cable tie.
16. Plug thermistor into wire harness.
17. Return water pump and water level sensor to its normal position. Reconnect power and ground wires.
18. Return bin and hood to their normal positions.
19. Reconnect electrical power and push the Freeze button to restart the machine.
20. Return the grills to their normal position.

Disconnect electrical power before beginning.

1. Remove the grills from the front of the cabinet.
2. Push and hold the Off button to shut the machine Off.
3. Remove the hood.
4. Remove the bin.
5. Locate the thermistor attached to the discharge line of the compressor. Remove the insulation covering the thermistor and un-clip it from the discharge line.
6. Unplug the thermistor from the wire harness by AutoIQ Controller.
7. Plug the new set into the AutoIQ Controller.
8. Route the thermistor to the discharge tube of the compressor and attach it to the discharge line in the same place as the original.
9. Re-cover the thermistor with insulation.
10. At the upper left of the machine, un-plug the water pump and water level sensor.
11. Lift up the water pump mounting plate and pull the water hose off the water pump. Remove the water pump and water level sensor and set aside.
12. Remove the water thermistor from the discharge hose of the water pump.
13. Unplug the thermistor from the wire harness.

## Water Distributors

Water Distributors are a snap-fit on the top edge of the evaporators.  
They are interchangeable left to right and front & back.

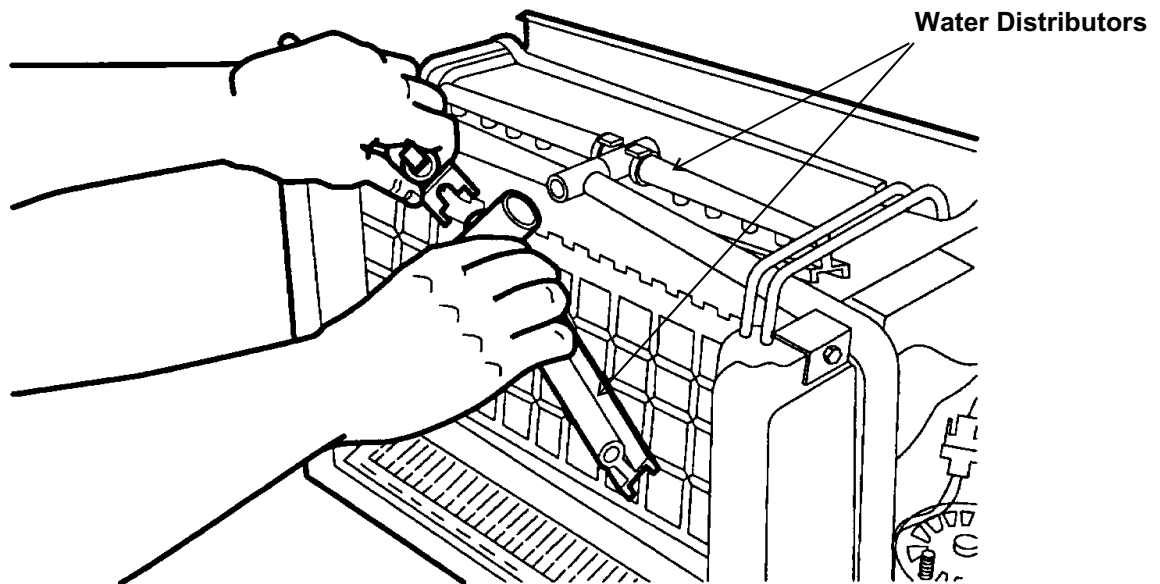

When the water distributor's have been removed, the top edge of the evaporator is exposed. That edge has small slots in it. Those slots must be clear of mineral scale build up to keep the water distribution even.

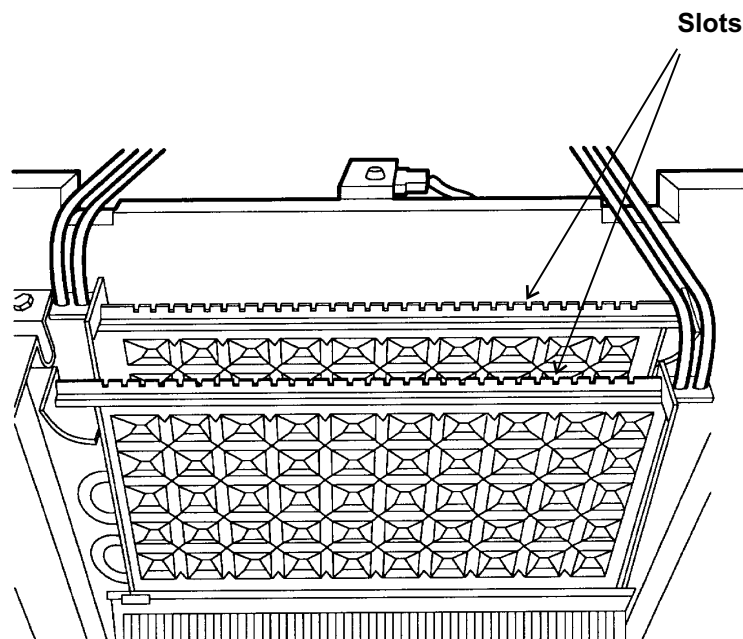

# SCE275

## Refrigeration System Service: R-404A

**This ice machine uses R-404A refrigerant and polyolester oil. Do NOT use mineral oil in this refrigeration system.**

R-404A is a “Near Azeotrope” so liquid charging is required:

- ✘ Weigh in as liquid as much of the charge as possible into the discharge line.
- ✘ Install a sight glass between the manifold and the suction side hose and carefully meter liquid into the suction side, using the manifold valve to “flash off” the liquid before it enters the ice machine. Do this until the proper amount of refrigerant has been weighed into the system.

When the system is serviced, a special liquid line drier is required. It is included with replacement compressors.

R-404A is not compatible with mineral oil, so these ice machines use Polyolester oil. Polyolester oil absorbs water very easily. When one of these refrigeration systems is opened for service, it must be re-sealed as soon as possible (15 minutes maximum).

Special leak detection equipment is required to locate small refrigerant leaks. Usually a leak detector capable of detecting a Halogenated refrigerant or R-134a will work. Check with the leak detector manufacturer if in doubt.

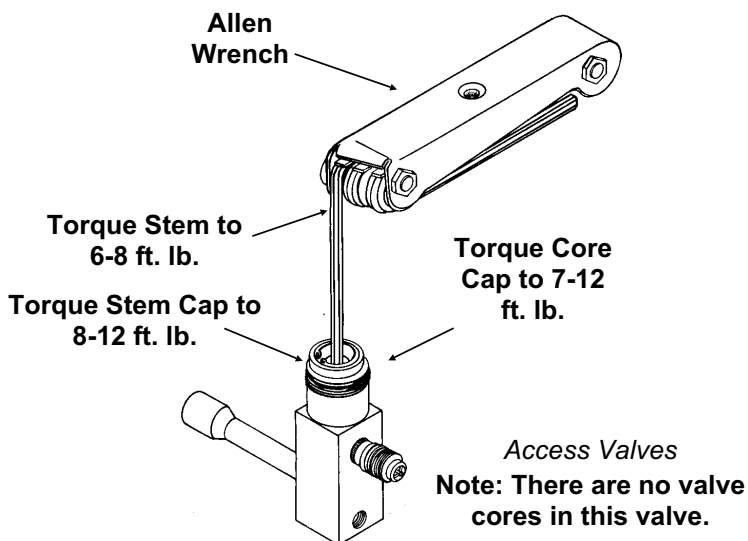

### Liquid Charging

In preparation for charging, the low side hose should have a sight glass, and/or a restrictor device (such as a “Charge Faster”) installed in it for metering liquid into the low side of the system.

1. After a thorough evacuation to at least 300 microns, shut off the manifold valves and switch off the vacuum pump.
2. Place a drum of R-404A onto an electronic scale.
3. Attach the charging hose to the drum.
4. Open the valve on the drum and purge the charging hose.
5. Zero out the scale.
6. Shut the low side access valve at the ice machine.
7. Open the discharge manifold valve full open.
8. Watch the scale, when the correct charge is shown, shut the manifold valve.

Note: If all of the charge will not “go in” the discharge side:

- A. Shut the discharge access valve at the ice machine.
- B. Switch the machine on.
- C. Open the low side access valve at the ice machine.
- D. Open the low side manifold valve and observe the sight glass to be certain that only gas is flowing into the system.
- E. When the proper charge is indicated on the scale, shut off the manifold valve(s).

9. Shut off the valve on the refrigerant drum.
10. Re-open the manifold valves until all liquid has flowed out of the hoses.
11. Shut the low side access valve on the ice machine.
12. Remove hoses from ice machine and replace all caps.