

# SCE275 Service Parts

This is the service parts list for the SCE275. This product was manufactured in both 60 Hz and 50 Hz models. The model number is different for each voltage. 60 Hz are designated with a -1 or -32 at the end, for example: SCE275A-1A or SCE275A-32G. 50 Hz models use a -6 at the end, such as SCE275A-6A.

Electrical parts that belong to the different voltages are described as 115/60, 208-230/60 or 50 Hz.

Changes between the A and D series relate to the compressor's starting components.

The E series changes were to the electrical system of the 50 Hz model.

The F series water cooled models began the use of a different water cooled condenser.

The G series moved the controller to the left side of the chassis.

## Table of Contents

Cabinet	Page 2
Air Cooled	Page 3
Water Cooled	Page 4
Refrigeration Components	Page 5
Water System	Page 6
Compressor, Controller, Water Valve	Page 7
Electrical Box	Page 8
Wire Harnesses	Page 9
Wiring Diagram, A series	Page 10
Schematic Diagram	Page 11
60 Hz Wiring Diagram: D, E, F and G Series	Page 12
50 Hz Wiring Diagram: - 6E, -6F, and -6G	Page 13

# SCE275 Service Parts

## Cabinet

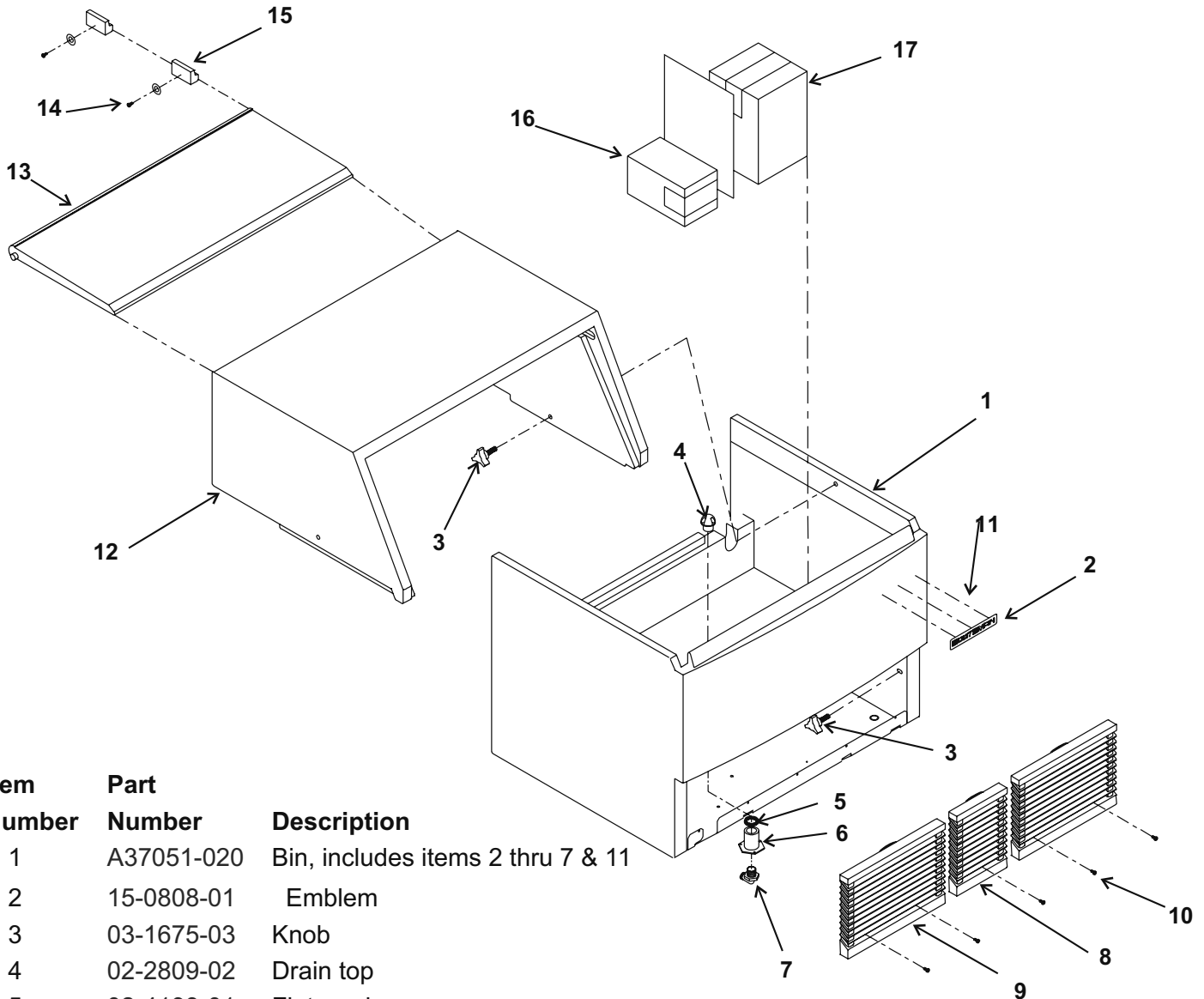

Item Number	Part Number	Description
1	A37051-020	Bin, includes items 2 thru 7 & 11
2	15-0808-01	Emblem
3	03-1675-03	Knob
4	02-2809-02	Drain top
5	02-4193-01	Flat washer
6	02-3108-01	Drain fitting
7	16-0822-01	Elbow
8	02-3458-31	Center grill
9	02-3153-31	Grill
10	03-1638-03	Screw
11	03-1562-01	Speed clip
12	A37050-021	Hood, includes items 3, 14, and 15
13	02-3439-31	Door
14	03-1419-22	Screw
15	19-0629-02	Door stop
16	KLP2	Leg kit
17	02-3253-01	Scoop

# SCE275 Service Parts

## Air Cooled

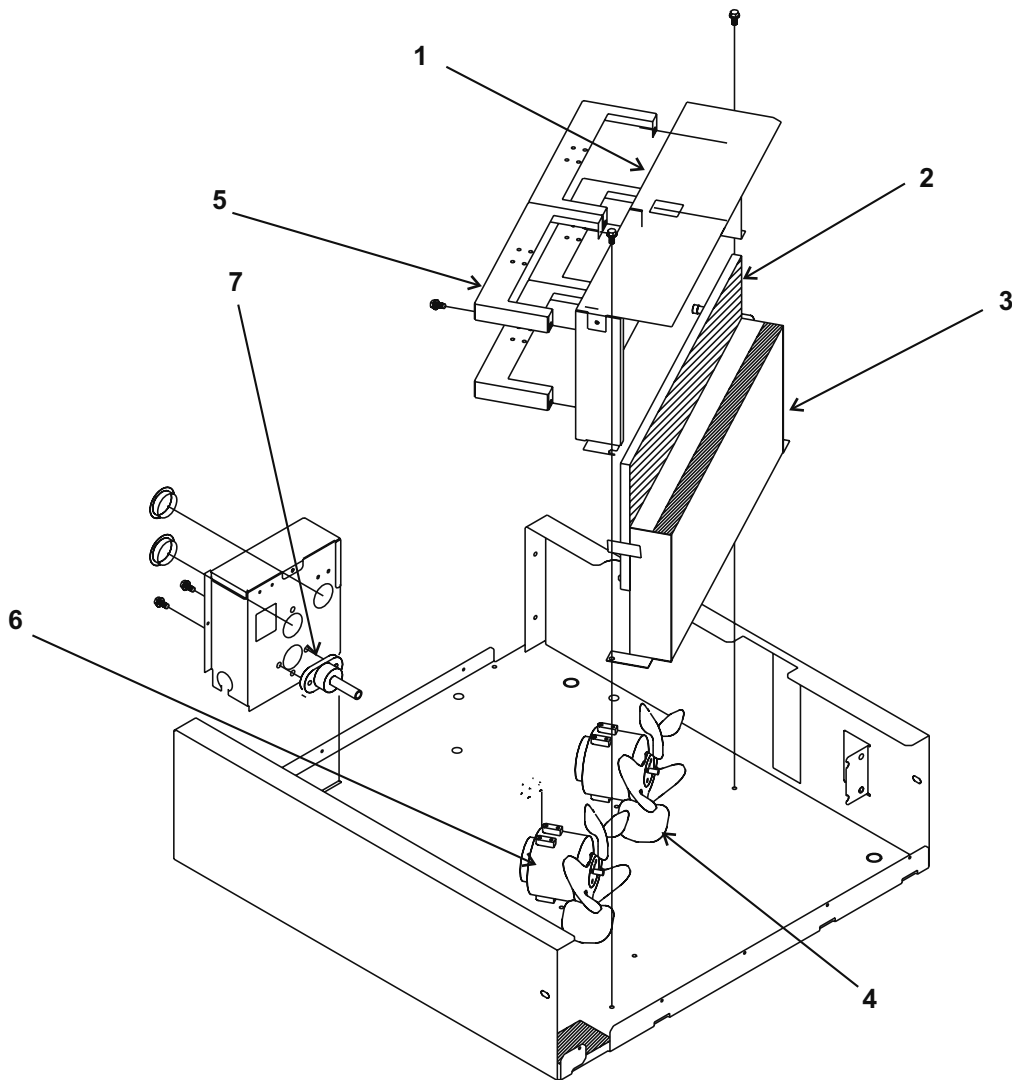

Item Number	Part Number	Description
1	A36742-001	Fan shroud
2	02-3193-01	Air filter
3	18-8782-01	Condenser
4	18-8773-01	Fan blade
5	A37320-001	Fan motor bracket
6	12-1681-23	Fan motor, 115/60 Hz
	12-1681-04	Fan motor, 50 Hz
	12-1681-04	Fan motor, 208-230/60
7	02-3692-23	Drain fitting



# SCE275 Service Parts

## Water Cooled

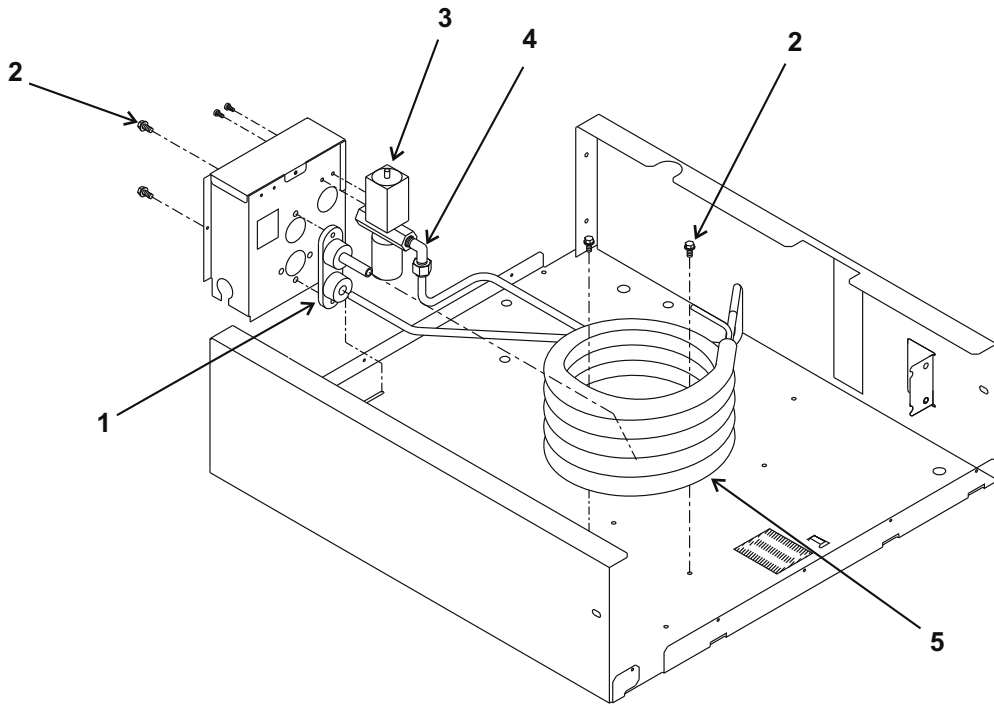

Item Number	Part Number	Description
1	A31878-001	Drain fitting
2	03-1645-02	Screw
3	11-0478-01	Water regulating valve
4	16-0401-00	Elbow
5	18-8803-25	A - E series water cooled condenser
	18-8871-01	F & higher series water cooled condenser

# SCE275 Service Parts

## Refrigeration Components

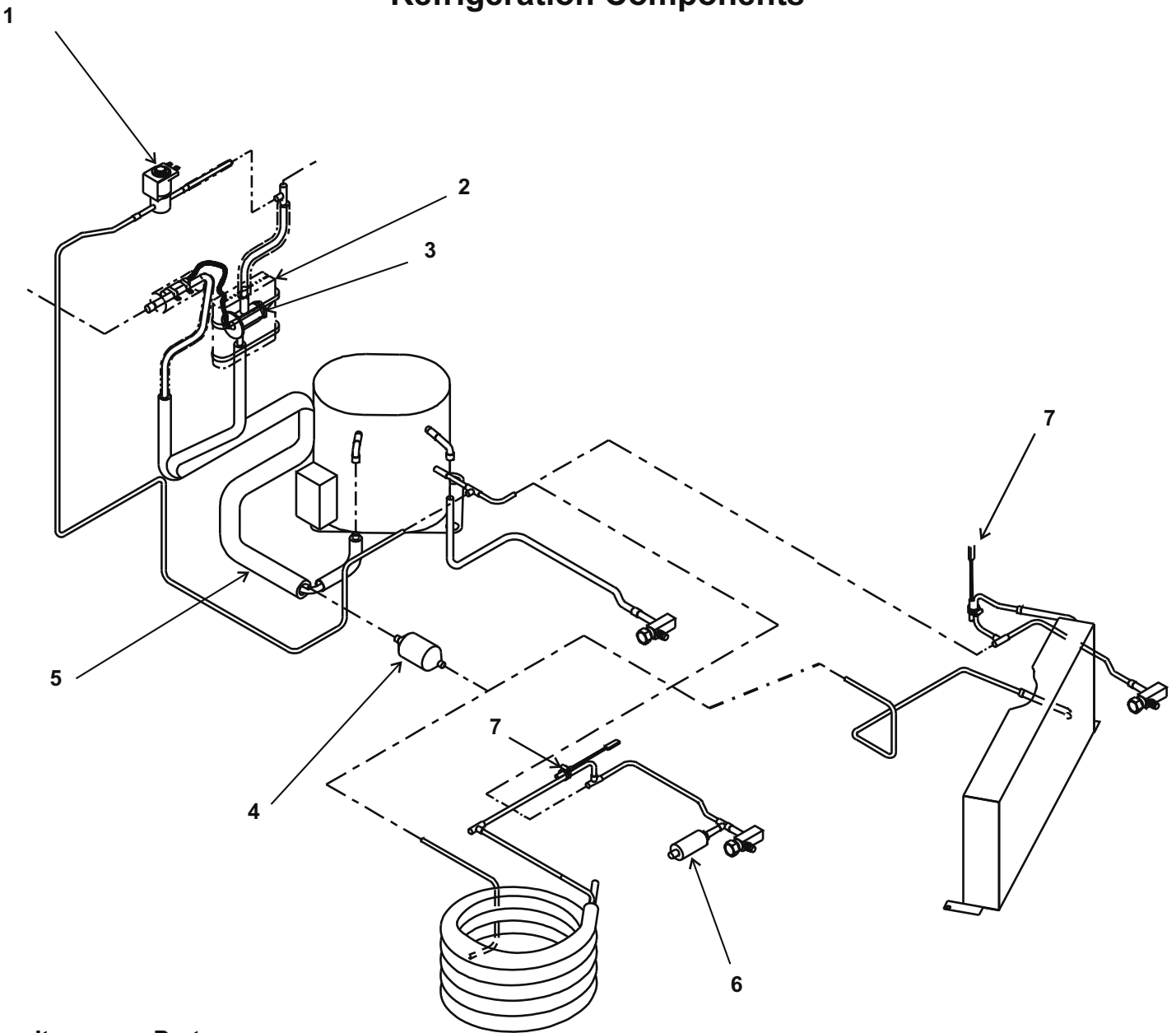

Item Number	Part Number	Description
1	12-2471-01	Hot gas valve w/coil
	12-2719-23	Coil for hot gas valve
2	02-3792-02	Insulation
3	16-1009-22	TXV
4	02-3319-01	Drier
5	A36637-001	Suction line
6	11-0501-21	Hi pressure cut out (WC)
	11-0501-05	Hi pressure cut out (AC)
7	12-2556-21	Thermistor

# SCE275 Service Parts

## Water System

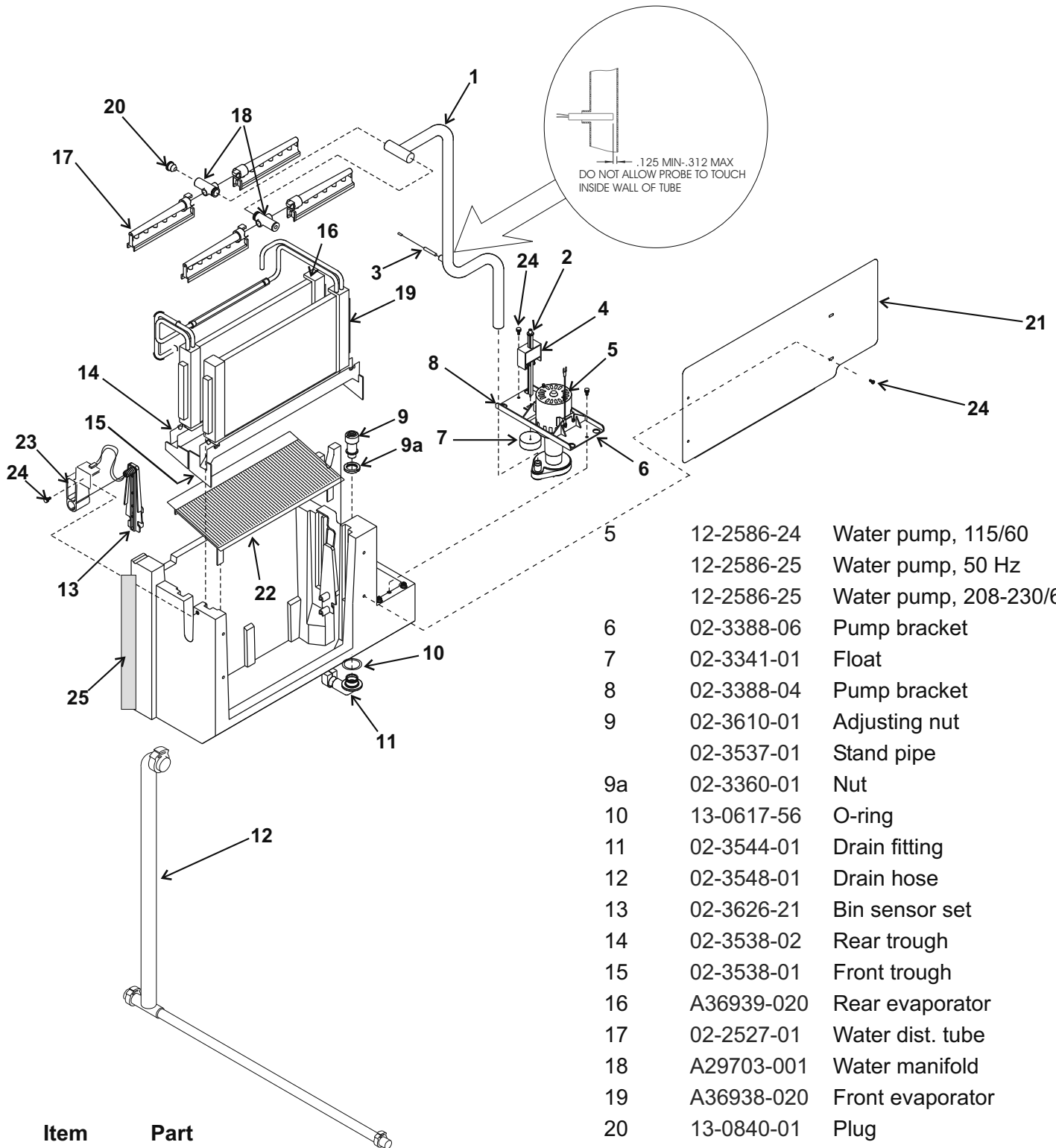

5	12-2586-24	Water pump, 115/60
	12-2586-25	Water pump, 50 Hz
	12-2586-25	Water pump, 208-230/60
6	02-3388-06	Pump bracket
7	02-3341-01	Float
8	02-3388-04	Pump bracket
9	02-3610-01	Adjusting nut
	02-3537-01	Stand pipe
9a	02-3360-01	Nut
10	13-0617-56	O-ring
11	02-3544-01	Drain fitting
12	02-3548-01	Drain hose
13	02-3626-21	Bin sensor set
14	02-3538-02	Rear trough
15	02-3538-01	Front trough
16	A36939-020	Rear evaporator
17	02-2527-01	Water dist. tube
18	A29703-001	Water manifold
19	A36938-020	Front evaporator
20	13-0840-01	Plug
21	02-3674-01	Evaporator cover
22	02-3337-03	Deflector
23	02-3528-01	Housing
24	03-1691-01	Nylon screw
25	02-3737-01	Filler gasket

Item Number	Part Number	Description
1	02-3547-01	Water hose
2	02-3383-03	Float stem
3	12-2556-21	Thermistor
4	11-0539-51	Water level sensor

# SCE275 Service Parts

## Compressor, Controller, Water Valve

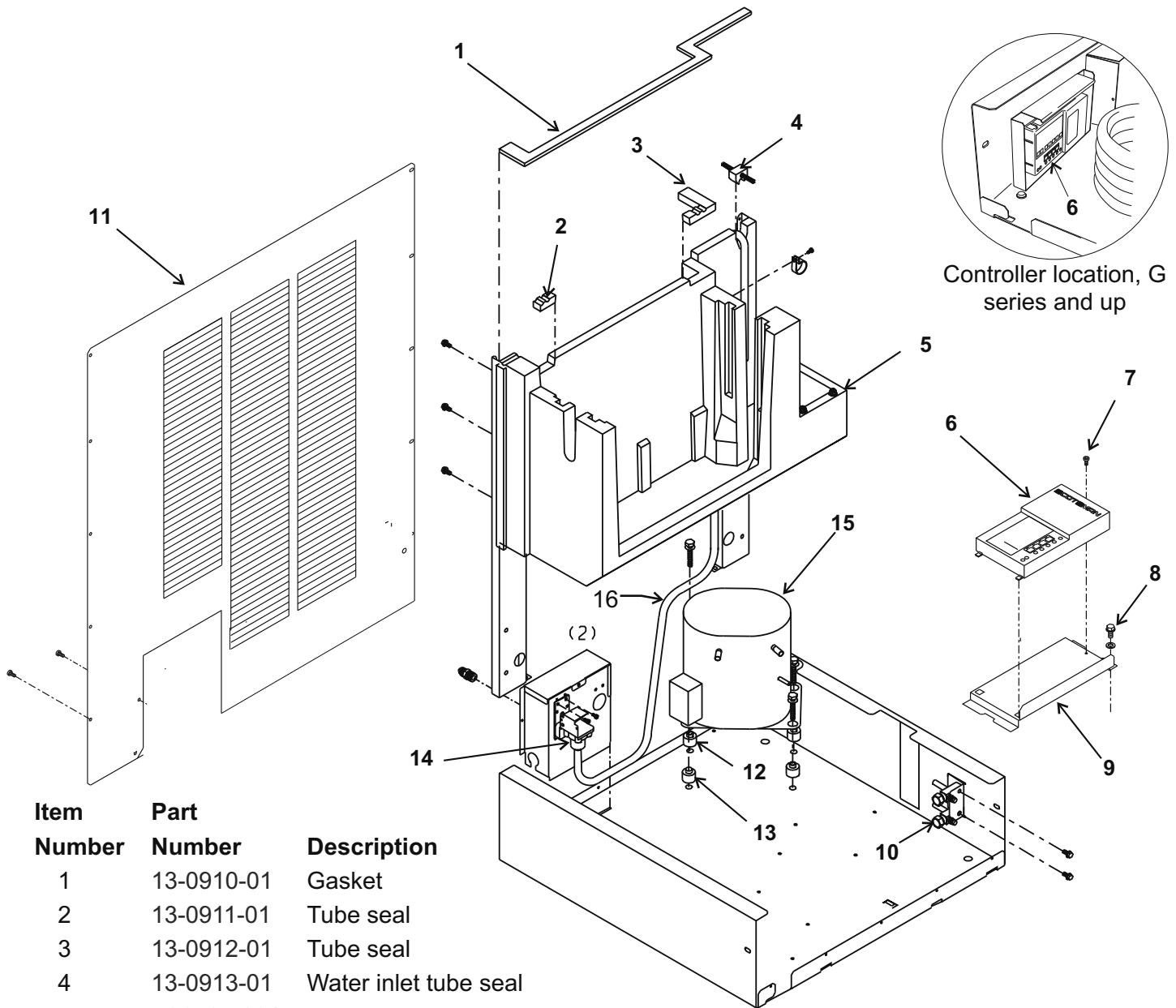

Controller location, G  
series and up

Item Number	Part Number	Description
1	13-0910-01	Gasket
2	13-0911-01	Tube seal
3	13-0912-01	Tube seal
4	13-0913-01	Water inlet tube seal
5	A36784-001	Evaporator housing
6	12-2838-23	Controller
7	03-1638-03	Screw
8	03-1645-02	Screw
9	obsolete	Bracket
10	16-0832-21	Service valve
10a	16-0832-03	Port cap
10b	16-0832-02	Stem cap
11	A36608-001	Back panel
12	03-1677-01	Screw - inserts from below
	03-1406-01	Hex nut
	03-1407-07	Washer
	13	18-0108-41 Mounting sleeve
		18-2300-27 Grommet
	14	12-2548-01 Inlet water valve
	15	18-8774-21 Compressor, 115/60
		18-8774-23 Overload for 115/60
		18-8774-26 Compressor, 230/50/1
		18-8774-27 Overload for 50 Hz
		18-8774-22 Compressor 208-230/60
		18-8774-28 Overload for 208-230/60
	16	02-3461-01 Inlet water hose

# SCE275 Service Parts

## Electrical Box

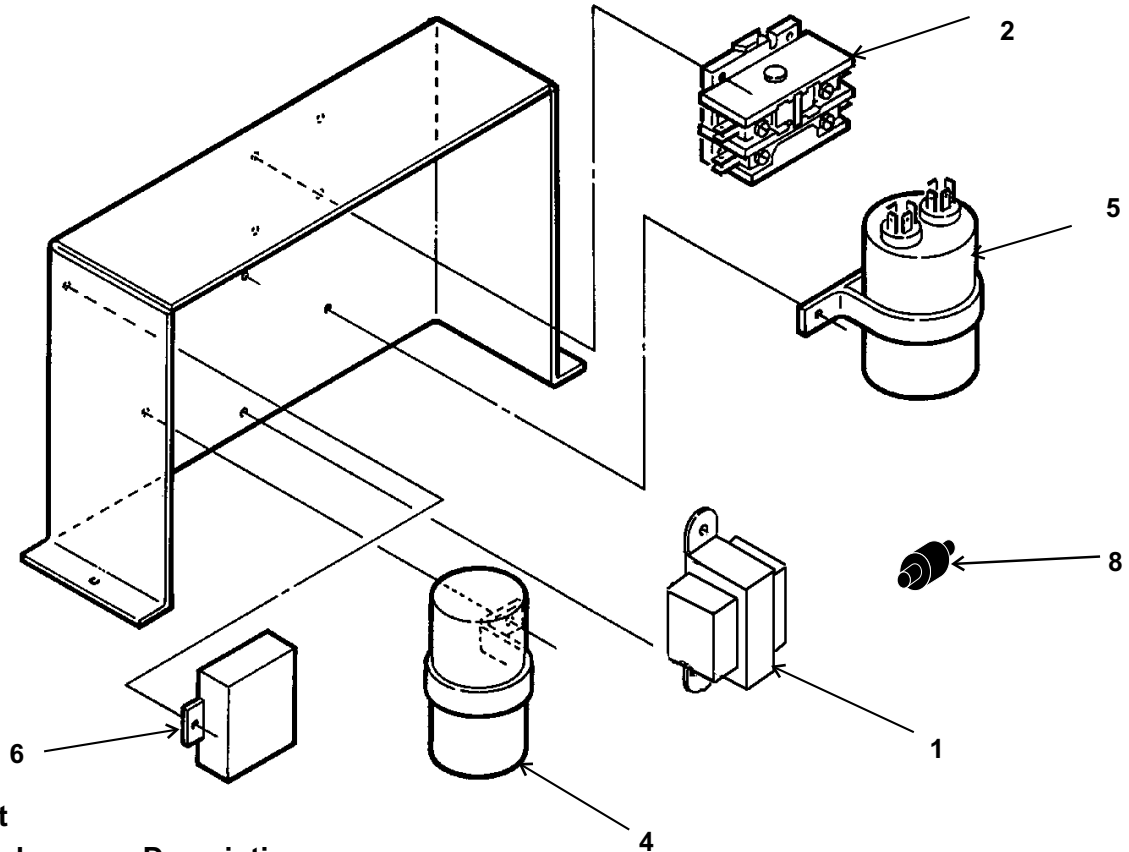

Item Number	Part Number	Description
1	12-2836-01	Transformer, 115/60
	12-2836-02	Transformer, 230/60 or 50 Hz
2.	12-2469-01	Contactor
3	12-2563-01	Control box harness
4	18-1901-55	Start capacitor, 115/60 Hz
	18-1901-56	Start capacitor, 50 Hz
5	18-1902-45	Run capacitor, 115/60 Hz
	18-1902-52	Run capacitor, 50 Hz
	18-1902-52	Run capacitor 208-230/60
6	18-1903-52	Potential Relay, 115/60 Hz
	18-1903-53	Potential Relay, 50 Hz
7	12-1638-14	Power cord, 115/60 Hz
	12-1638-18	Power cord, 208-230 60 or 50 Hz
8.	18-8835-01	PTCR
9.	A36855-001	Cover for control box



# SCE275 Service Parts

## Wire Harnesses

Wire Harnesses are NOT ILLUSTRATED, select by model number and description

A through F series models have single harnesses

G series 60 Hz have single harnesses

G series 50 Hz have split harnesses

<b>Part Number</b>	<b>Description</b>
--------------------	--------------------

12-2620-01	Main wire harness WC for A - F series
------------	---------------------------------------

12-2619-01	Main wire harness AC for A - F series
------------	---------------------------------------

12-2900-01	Main wire harness AC for G series 60 Hz
------------	---

12-2901-01	Main wire harness WC for G series 60 Hz
------------	---

12-2894-01	24 volt wire harness, AC for G series 50 Hz
------------	---

12-2893-01	Pump wire harness, WC for G series 50 Hz
------------	--

12-2895-01	Pump and fan wire harness, AC for G series 50 Hz
------------	--

12-2892-01	24 volt wire harness, WC for G series 50 Hz
------------	---

# SCE275 Service Parts

## Wiring Diagram, A series

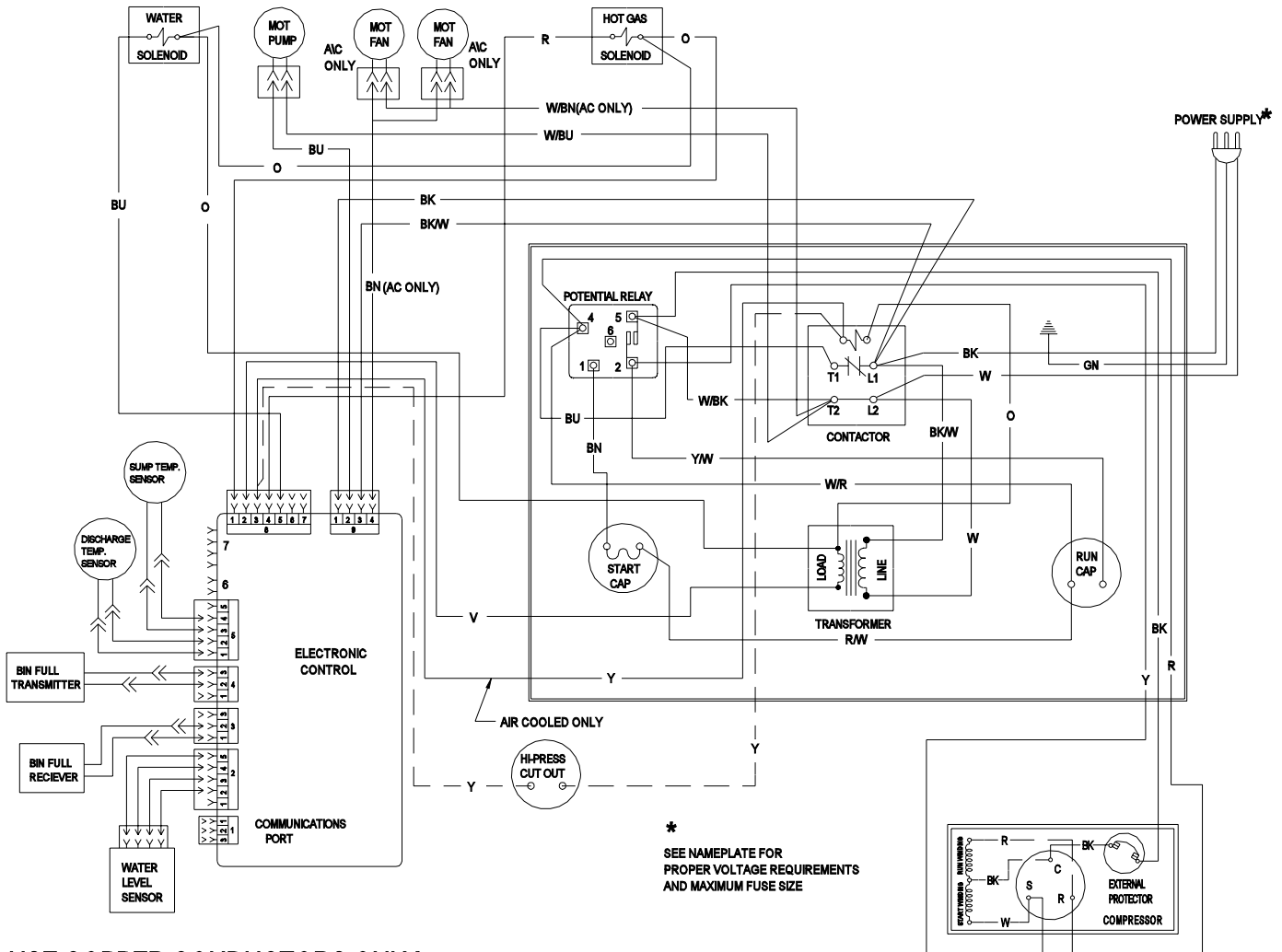

**USE COPPER CONDUCTORS ONLY**

THIS UNIT MUST  
BE GROUNDED.

**CAUTION:**

MORE THAN ONE DISCONNECT MEANS MAY BE  
REQUIRED TO DISCONNECT ALL POWER TO THIS UNIT.

# SCE275 Service Parts

## Schematic Diagram

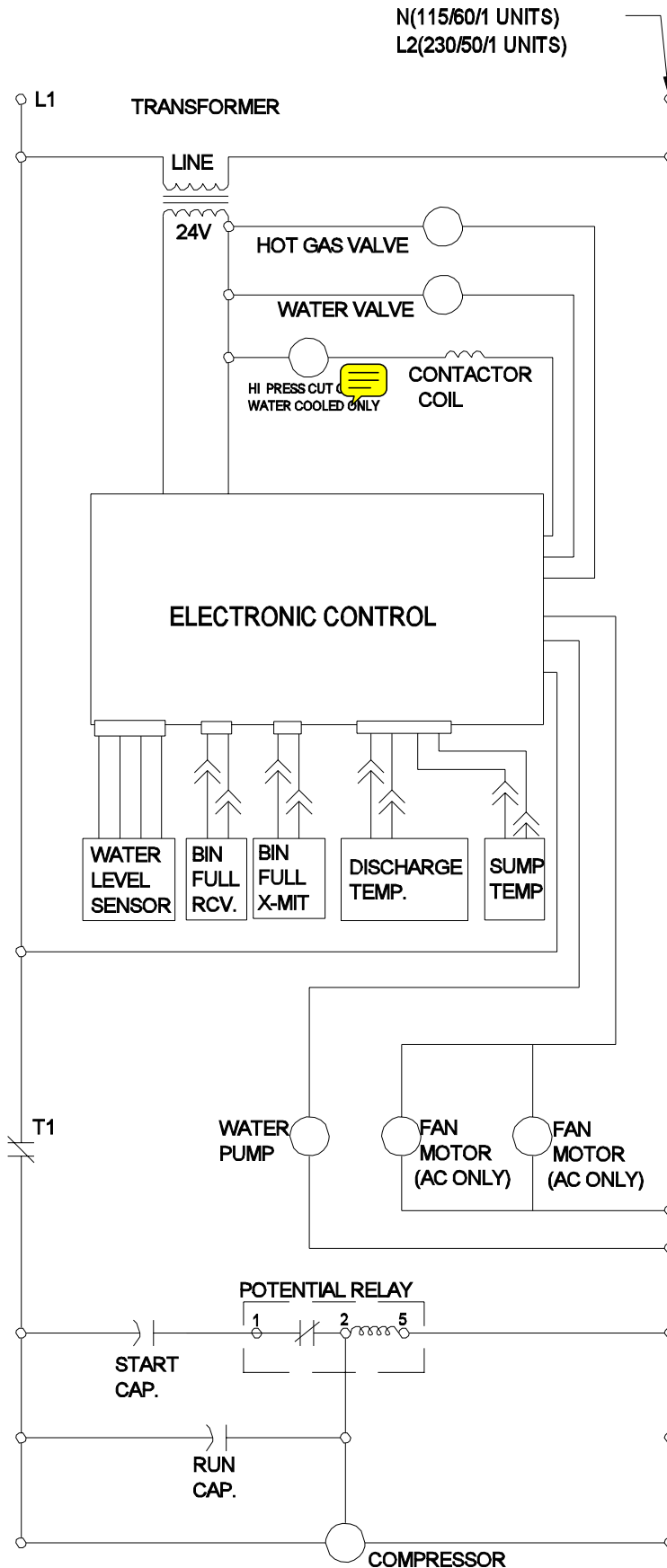

# SCE275 Service Parts

## 60 Hz Wiring Diagram: D, E, F, G and H Series

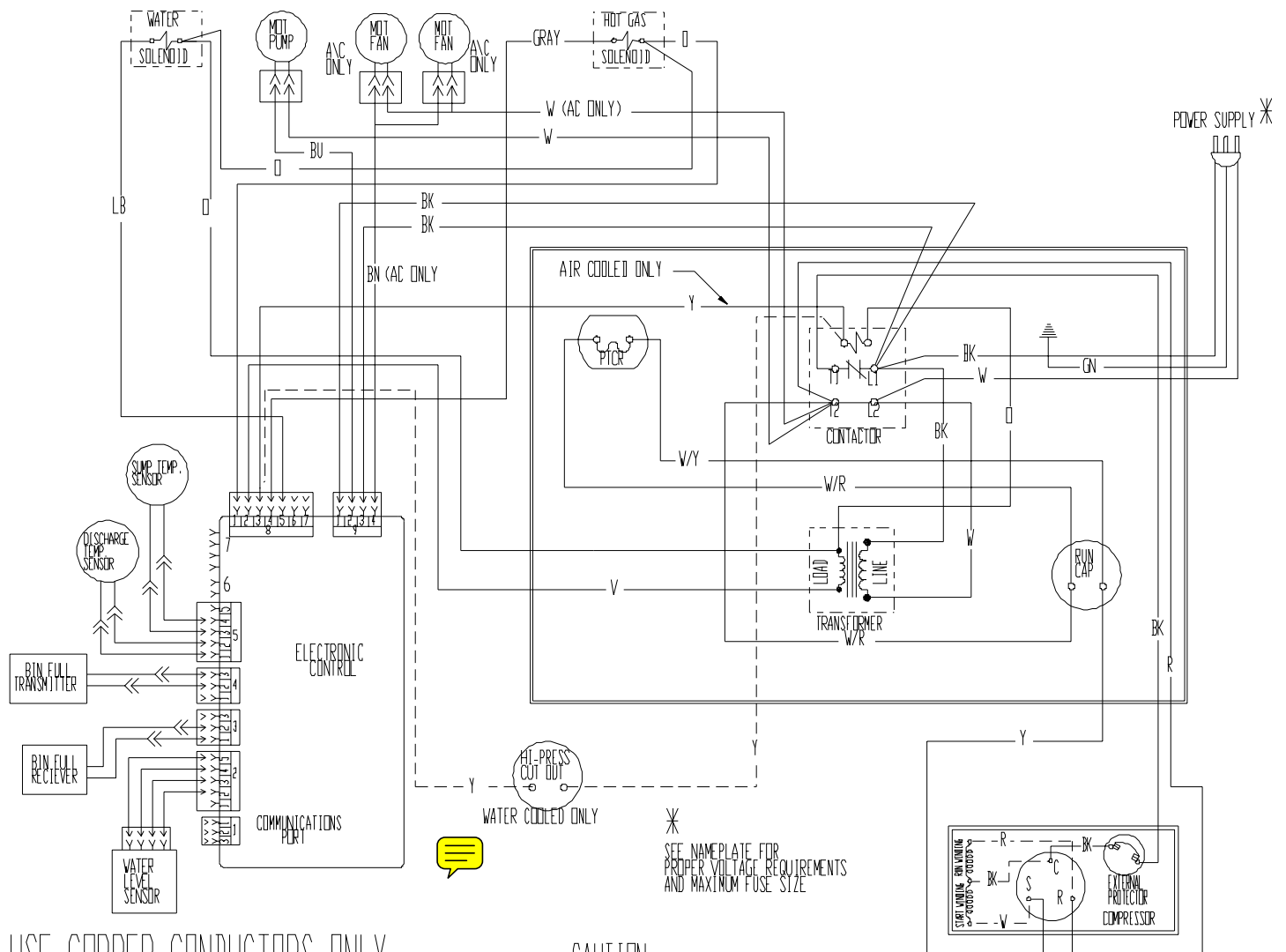

USE COPPER CONDUCTORS ONLY

THIS UNIT MUST BE GROUNDED.

CAUTION:

MORE THAN ONE DISCONNECT MEANS MAY BE REQUIRED TO DISCONNECT ALL POWER TO THIS UNIT.

# SCE275 Service Parts

## 50 Hz Wiring Diagram: - 6E, -6F, and -6G

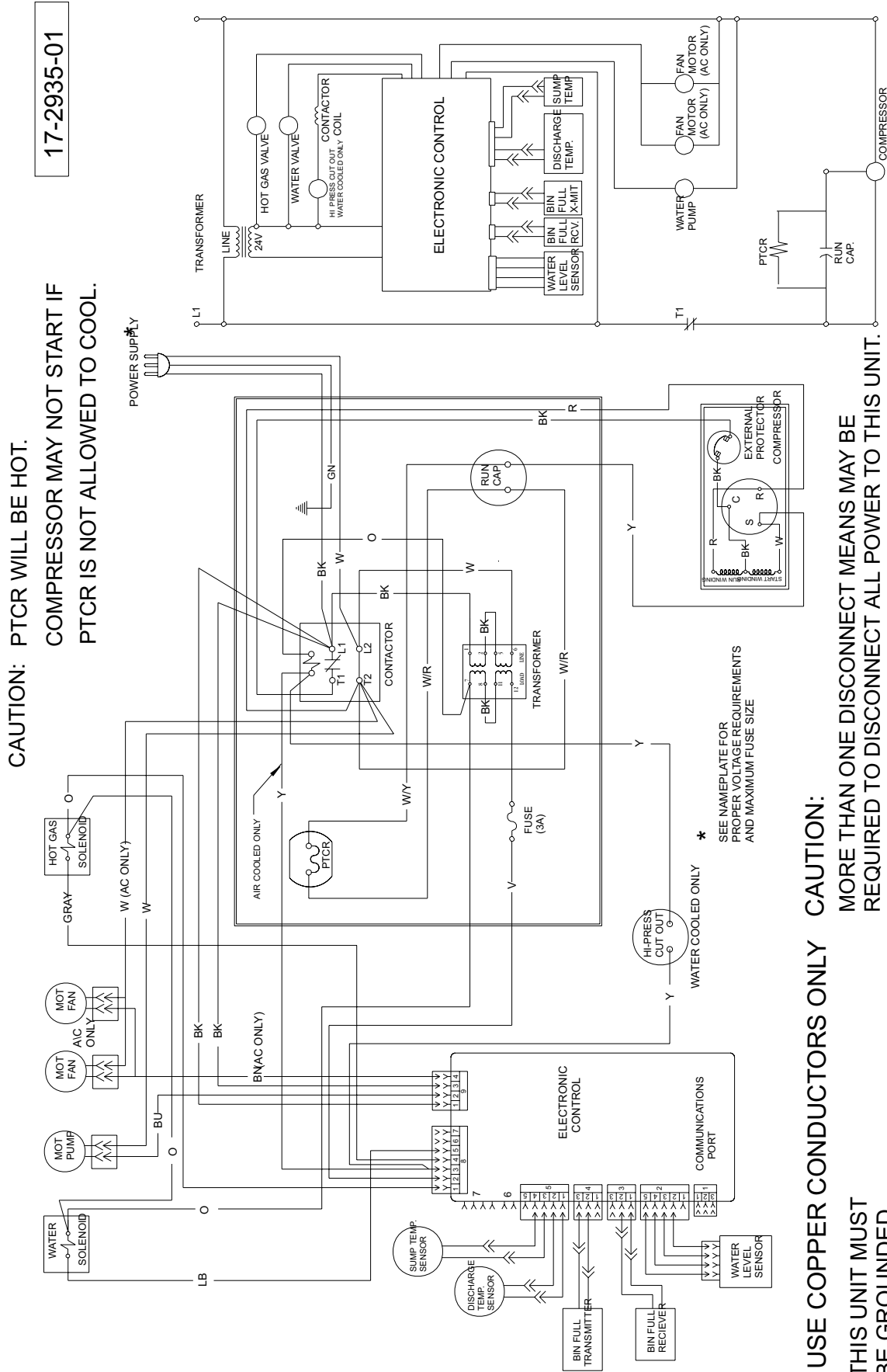

17-2935-01

**CAUTION: PTCR WILL BE HOT.**  
**COMPRESSOR MAY NOT START IF PTCR IS NOT ALLOWED TO COOL.**

**USE COPPER CONDUCTORS ONLY**

**CAUTION:**  
**MORE THAN ONE DISCONNECT MEANS MAY BE REQUIRED TO DISCONNECT ALL POWER TO THIS UNIT.**

---

# SERVICE BULLETIN

---

## Subject: SCE275 Model Series Change

The SCE275 is now being manufactured as a G series. G series and higher SCE275s have their AutoIQ controller on the left side wall of the chassis, instead of the right side chassis floor. The new location provides improved protection from water and debris.

Although the controller's buttons and lights are somewhat out of sight in the new location, they can be easily seen by flashlight.

Because of the controller move, the wire harnesses have also changed.

12-2900-01 Main wire harness AC for G series 60 Hz

12-2901-01 Main wire harness WC for G series 60 Hz

12-2894-01 24 volt wire harness, AC for G series 50 Hz

12-2895-01 Pump wire harness, WC for G series 50 Hz

12-2895-01 Pump and fan wire harness, AC for G series 50 Hz

12-2892-01 24 volt wire harness, WC for G series 50 Hz

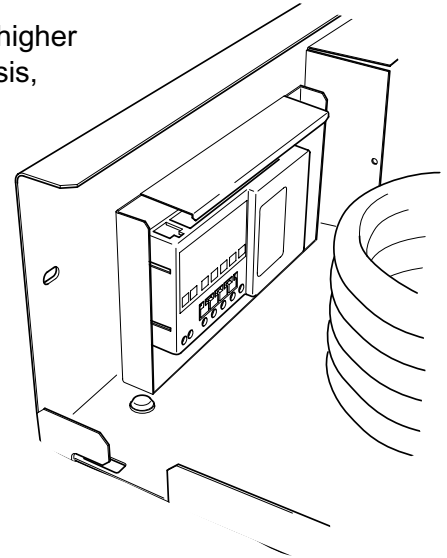

*New Location for Controller*