

Introduction

To the owner or user: This service manual is intended to provide you, and the maintenance or service technician, with the information needed to install, start up, clean, maintain and repair this product.

The SLE400 is an ice machine that produces cubed ice on 6 vertical cube freezing surfaces.

When harvested, the cubes fall individually into the ice storage bin. The SLE400 automatically maintains the level of ice by turning on when the ice level falls, and switches off when the bin is full.

The refrigeration system uses R-404A as the refrigerant.

Table of Contents

Specifications	page 2
Limitations	page 3
Installation	
General	page 4
Bin	page 5
SLD dispenser	page 6
RS or IS dispenser	page 7
Plumbing	page 8
Electrical	page 9
Final Check List	page 10
Component Location	page 11
Initial Start Up	page 12
Electrical Sequence	page 13
Cleaning	page 14
Water/ Refrigeration Schematic	page 16
Technical Characteristics	page 18
Service Diagnosis	page 19
Removal and Replacement	page 22

Parts lists and wiring diagrams are located in the center of this manual, printed on yellow paper.

Note the warning symbol where it appears in this manual. It is an alert for important safety information on a hazard that might cause serious injury.

Keep this manual for future reference.



This manual was printed on recycled paper.

SLE400

Specifications

Information regarding Model Number, Serial Number, Ampacity and Maximum Fuse Size are located on the nameplate of the ice machine. The model number, serial number and refrigerant charge are also listed on the serial number plate just behind the front panel.

If recharging, always use the charge listed on the ice machine.

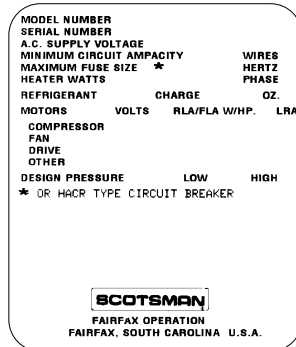

SLE400 Cabinet

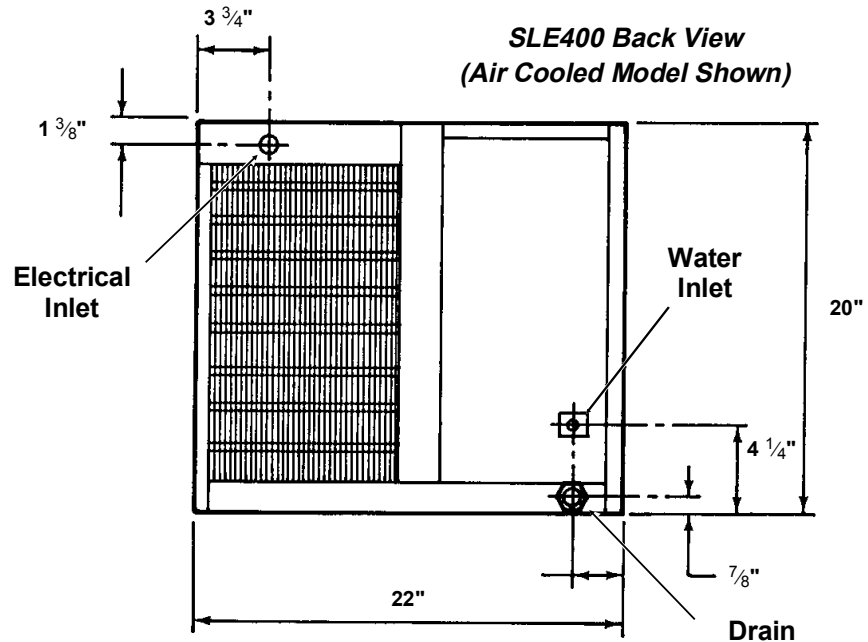
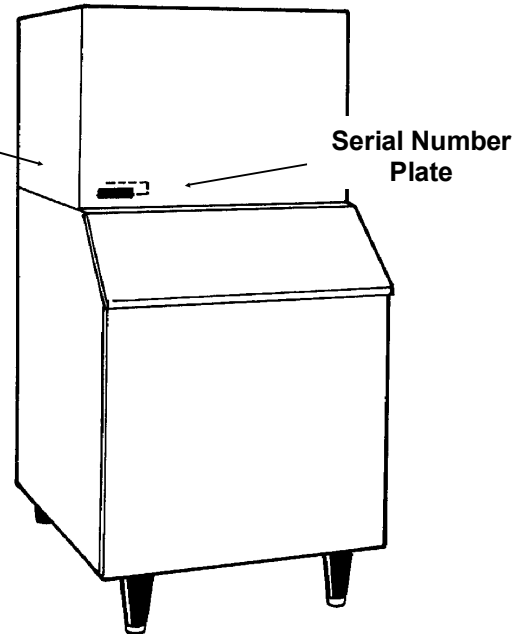

Specifications:

The SLE400 will stack onto a variety of ice storage bins, see sales literature for proper ice storage bin.

Model Number	Dimensions W" x D" x H"	Condenser Type	Basic Electrical	Minimum Circuit Ampacity*	Maximum Fuse Size (or HACR circuit breakers)	Refrigerant Charge. R-404A
SLE400AS-1A	22 x 23 x 20	Air	115/60/1	22.3	25	19 ounces
SLE400WS-1A	22 x 23 x 20	Water	115/60/1	18	20	18 ounces

* Minimum Circuit Ampacity is used to determine wire size and type per the National Electric Code.

For The Installer: Environmental Limitations

The ice machine must be installed indoors in a controlled environment.

	Minimum	Maximum
Air Temp	55⁰F.	100⁰F.
Water Temp	40⁰F.	90⁰F.
Water Pressure	20 PSI	60 PSI
Voltage	103.5	126.5

Operating the ice machine outside of the above limitations, or outdoors, is potentially damaging to the machine, and it is misuse of the machine. This may void the warranty.

Scotsman Ice Systems are designed and manufactured with the highest regard for safety and performance. They meet or exceed the standards of UL, NSF, and CSA.

Scotsman assumes no liability or responsibility of any kind for products manufactured by Scotsman that have been altered in any way, including the use of any part and/or other components not specifically approved by Scotsman.

Scotsman reserves the right to make design changes and/or improvements at any time.

Specifications and design are subject to change without notice.

Airflow on air cooled models is:

- Intake through the right side grill.
- Exhaust through the back.

**SLE400
Top View**

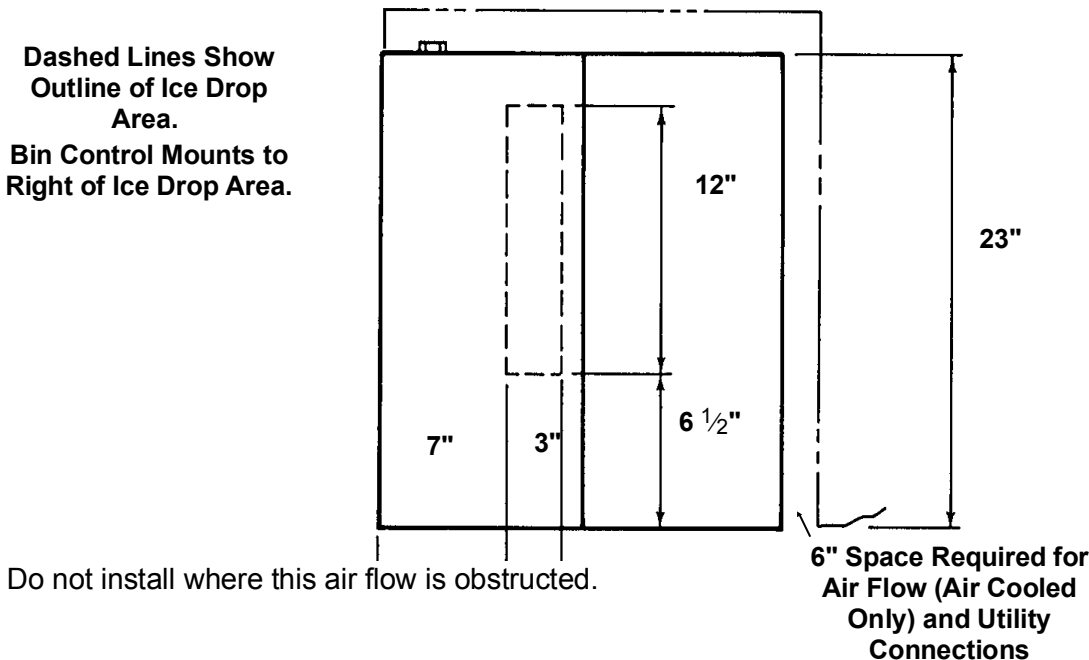

SLE400

Installation

Water

The water supply for this ice machine has been in contact with many materials since it fell from the sky as rain. All rain is slightly acidic, and tends to dissolve the materials it comes in contact with.

During water's journey to the ice machine, it has flowed over and through the ground, been picked up by a municipal or private pump, forced through a series of pipes of differing construction and may have been treated by the municipality providing the water.

The water supplied to this ice machine will then contain a variety of substances that will likely show up as solids during the ice making process. These solids are similar to those found when water is boiled out of a saucepan. Only the water boils away, and the minerals that were in the water solidify in the pan. During ice making only the water is frozen into ice, the minerals stay behind in the reservoir. This machine drains out some water in the reservoir every cycle to minimize the amount of minerals in the water system, but after time the minerals will appear and have to be dissolved by ice machine cleaner, then flushed away during the cleaning process.

An ice machine is a food manufacturing plant; it takes a raw material, in this case water, and transforms it into a food product, ice. The purity of the water is very important in obtaining pure ice and in maximizing product life.

The water to the ice machine should be filtered. Water filters vary greatly in ability and function. Install one that filters out suspended solids to a dimension of 5 microns or less. The finer the filter the better, but finer filters may plug-up sooner than course ones. It may be necessary to add a course filter ahead of the fine filter to prolong filter life. Polyphosphate feeders are usually effective in many water conditions.

Have the water tested. Acidic water or alkaline water will both cause corrosion. Dissolved solids cannot be filtered out. Softened water is not recommended. Never use de-ionized water. Reverse-osmosis water must be treated with buffering agents before use in the ice machine.

Check with a water treatment specialist regarding testing, treatment and filters.

Location

This ice machine may be installed in the open or under a counter. Clearance may be required at the sides, and is required at the back. Air cooled models take air in from the right and blow it out the back. Space is required for utility connections at the back.

The ice machine is NOT designed for outdoor use. It must be installed indoors, in a controlled environment. The air and water temperatures must not exceed rated limits.

Pre-installation:

1. Inspect the place where the ice machine is to be installed. Check for:

- space for the cabinet,
- water supply,
- drain availability
- and electrical power supply.

No extension cords are allowed. The building drain inlet must be lower than the drain outlet of the ice bin. The water supply must have a hand shut off valve accessible when the unit is installed.

Installation: Ice Storage Bin

Assembly:

1. Attach the legs, or optional casters, onto the ice storage bin. Units that are stacked should only use legs, not casters.
2. Be sure that the top edge of the bin has a good gasket on it.
3. Place the ice machine onto the storage bin.
4. Line up the ice machine, check that there is a good seal between the ice machine and the storage bin.
5. If on a Scotsman bin, attach the ice machine to the bin using the straps and bolts shipped with the ice machine. Drill two 1/8" holes in the back of the bin and secure with sheet metal screws provided. If on another brand bin, follow the directions included with that bin.

Bin Thermostat Installation:

1. Remove thermostat bracket from package.
2. Attach the bin thermostat bracket to the bottom of the ice machine using the thumb screws provided. There are pre-drilled and tapped holes located just to the right of the cube drop area.

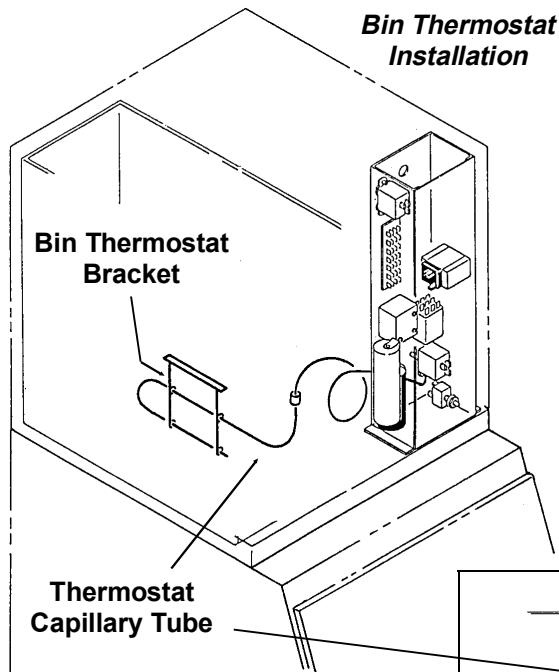

3. Locate and uncoil a portion of the bin thermostat capillary tube. Route the end of the capillary tube into the plastic tube in the base of the ice machine (next to the compressor) and through the bin thermostat bracket.

Note: SLB150: Use thermostat bracket packed with that bin.

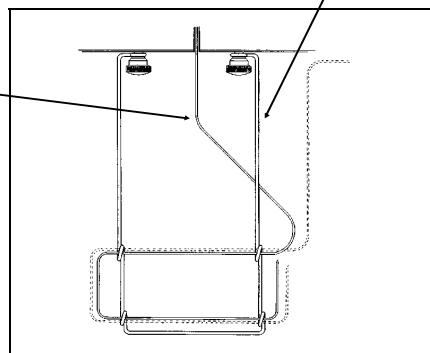

Stacking:

This machine will stack onto any SLC300 or SLE400. Note: Do **not** use casters when stacking.

1. Remove and discard the left top panel from the lower unit.
2. Remove knock out plug from top right panel.
3. Place gasket material around the top of the bottom unit's cabinet & evaporator compartment.
4. Carefully lift the uncrated top unit onto the bottom unit. Use of a mechanical lift is recommended for this step.
5. Align the two ice maker cabinets.
6. Secure the top unit to the bottom one with the hardware and straps shipped with the upper machine.
7. Locate and uncoil all of the bin thermostat capillary tube.
8. Route the bin thermostat capillary tube from the upper unit, through the hole in the base, through the lower unit and into the bin thermostat bracket. Discard upper unit bracket.

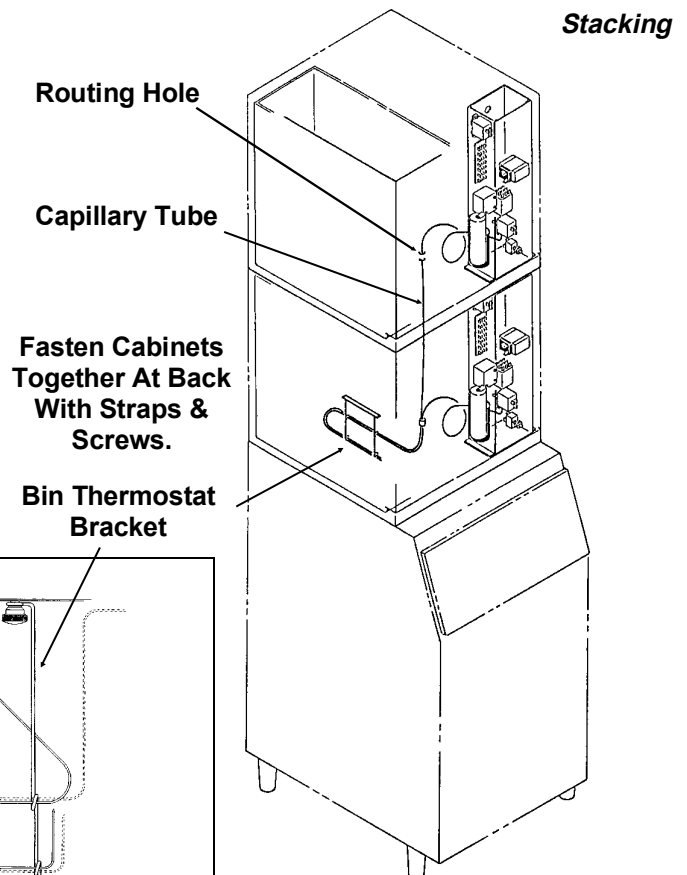

SLE400

Installation: SLD150 Hotel Dispenser

Assembly

The ice machine must be placed onto the top of the dispenser, and the bin thermostat capillary tube routed into the bracket in the dispenser.

1. Check that the dispenser has a gasket all around the perimeter of the top, 22" wide by 23" deep.
2. Locate the inlet hole of the thermostat bracket, and make sure that it is open.
3. Place a corner post from the ice machine carton at the front of left and right sides of the hotel dispenser top.
4. Use a mechanical lift and place the ice machine onto the dispenser. The cardboard corner posts should keep the front edge of the ice machine up.
5. Remove the front panel of the ice machine.
6. Locate the bin thermostat capillary tube and uncoil about 18" of tubing.
7. Locate plastic tube in base of ice machine, next to compressor and push the end of the capillary tube thru the tube, watch the capillary as it comes out of the base, line it up with the inlet hole of the thermostat bracket and push it into the hole. Move the cabinet of the ice machine until the capillary tube is going straight down into the inlet hole.
8. Carefully remove the corner posts.
9. Push the capillary tube into the thermostat bracket tube until about 14" of capillary tube is in the tube.
- 9 Remove the hardware package from the machine, remove brackets.
10. At the back of the dispenser, fasten brackets to the ice machine.
11. Using brackets for templates, drill 1/8" holes into the back of the dispenser.
12. Secure brackets to the dispenser with sheet metal screws from the hardware package.
13. Follow other installation instructions from the SLD150.

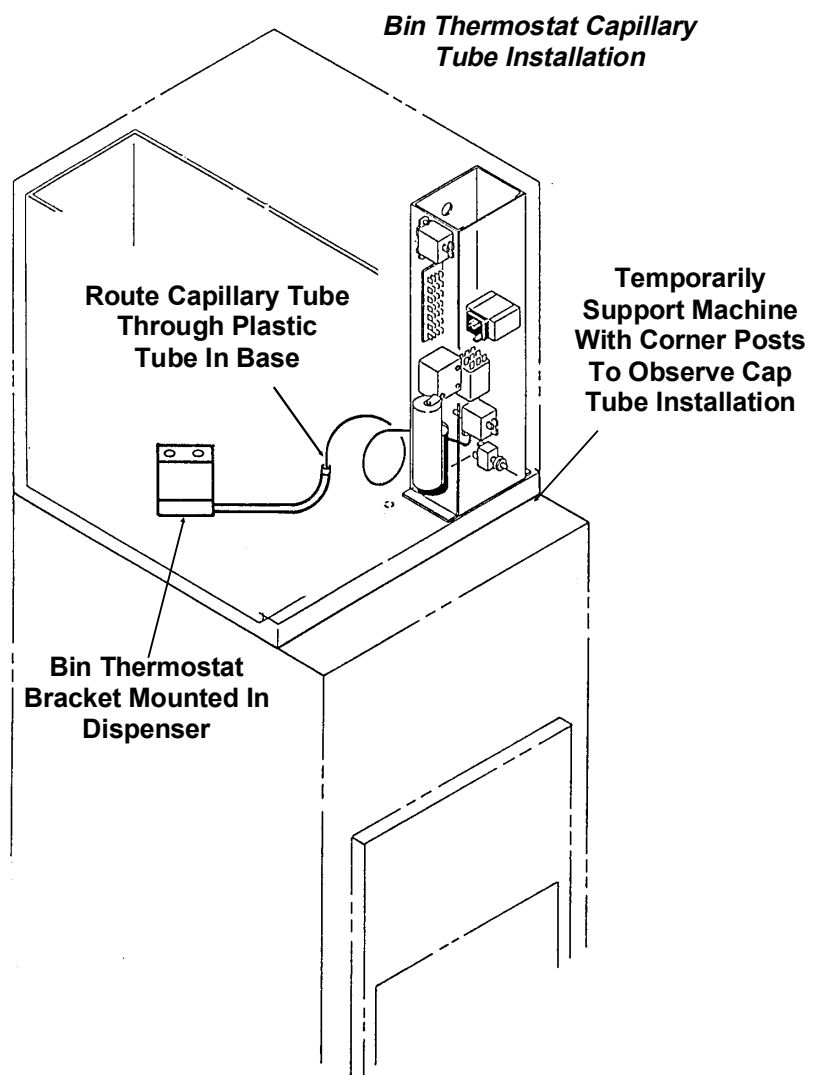

Installation: Scotsman IS or RS Dispenser

Assembly:

The assembly of the ice machine onto the dispenser requires two additional parts: an adapter kit and a thermostat stand off kit.

1. Mark two spots on the inside left liner of the dispenser: 2" down from the top, 4" from the back, and 4" apart.
2. At the two marked spots, drill two 1/4" holes thru the plastic liner only.
3. From the stand off kit, locate the stand offs and plastic anchors. Thread the stand offs partially into the plastic anchors.
4. Push the anchors/stand offs into the holes.
5. Screw the stand offs all the way into the anchors. Be sure that the holes in the stand offs are horizontal.
6. Place a bead of silastic (from the kit) around the stand offs.

7. From the adapter kit, place the stainless steel adapter onto the top of the dispenser. Follow all directions included with the kit.

8. After the ice machine has been placed on the dispenser, remove the front panel and uncoil all of the bin thermostat capillary tube.

9. Route the capillary tube thru the front hole in the base of the ice machine, to the left side if the dispenser towards the stand offs.

10. Route the end of the capillary tube thru the stand offs, bend the tube around the stand offs so that it does not fall off.

11. Check that the routing of the capillary tube is away from the ice chute and up high near the base of the ice machine.

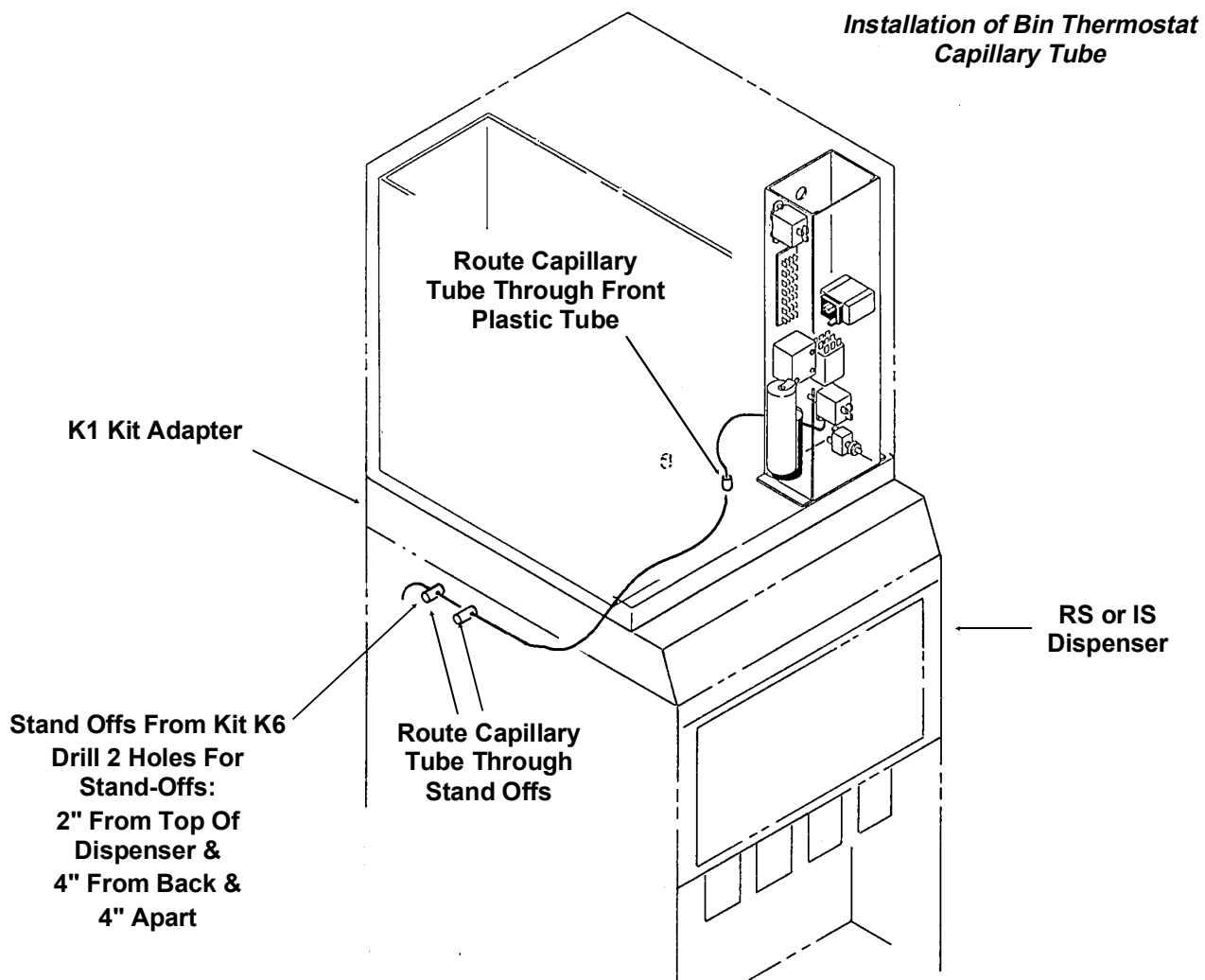

SLE400

Installation

For The Plumber

Supply:

Screw the 3/8" male flare (fitting shipped in package inside cabinet) into the 1/4" FPT fitting at the back of the cabinet (thread tape recommended). Connect cold potable water to the water inlet. A hand shut off valve for inlet water should be installed near the machine. A water filter is recommended. Flush the water line prior to connecting to the ice machine.

If water cooled, connect a separate water inlet line to the water cooled condenser inlet fitting. It should also have a hand shut off valve.

Drains:

Connect a drain tube to the reservoir drain fitting at the back of the cabinet. The drain tube from the fitting must be run separately from any other drain tube. The reservoir drain is a 3/4" F.P.T. brass fitting.

Drain tube material must be rigid and meet local code.

Traps in the bin drain line without vents ahead of them will cause poor draining.

The bin drain must be vented if there is a long horizontal run (5' or more). The reservoir drain must be vented and **not** connected to the bin drain. All drains are gravity, and must have a minimum fall of 1/4" per foot of horizontal run.

Water Cooled: The water cooled condenser drain is not vented, and is routed separately.

Maintain the air gap required by local code between the end of the drain tubes and the building drain receptacle.

Note: Drain tubing should be insulated to prevent condensation from forming on the tubing.

CONFORM TO ALL LOCAL CODES

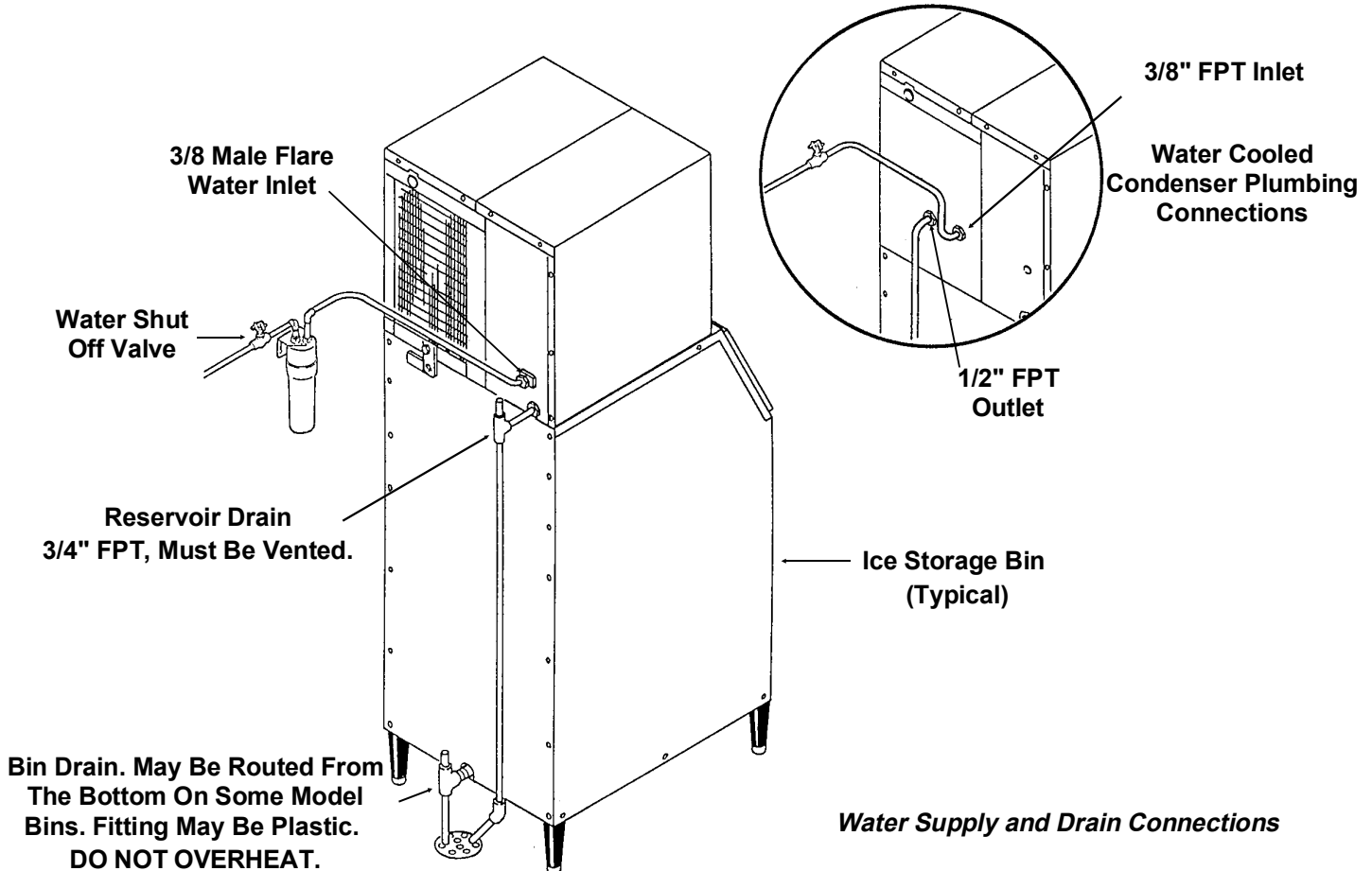

Installation

For The Electrician

This unit must be on a separate 115 volt AC 60 cycle single phase power supply. The maximum fuse size for this circuit is listed on the nameplate, and per the nameplate use fuses, or HACR circuit breakers.

Follow All Local Codes - This Unit Must Be Grounded. Usually a licensed electrician will be required to connect the electrical service.

To make the electrical connections:

1. Remove the right top panel.
2. Remove the junction box cover.
3. Make the electrical connections to the wires in the junction box. A ground screw is provided in the junction box.

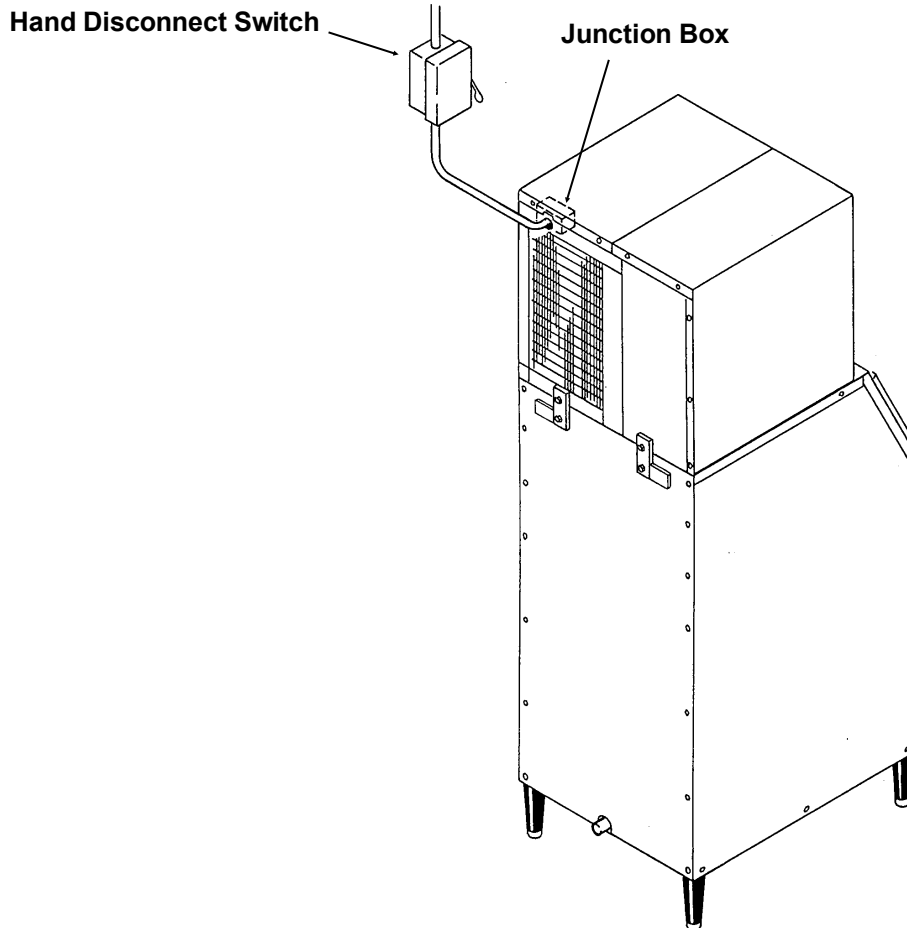

SLE400

After Utility Connections

1. Level the cabinet, use the leg levelers on the end of the legs to adjust the cabinet height. (Legs should have been installed when the bin was unpacked).
2. Wash out the bin. If desired, the interior of the bin could be sanitized.

Final Check List

1. Is the ice maker cabinet in a room where ambient temperatures are within the minimum and maximum temperatures specified?
2. Has the water supply been connected?
3. Is the water pressure adequate?
4. Have the water connections been checked for water leaks?
5. Have the drain connections been made?
6. Have the drain connections been checked for leaks?
7. Is the cabinet level?
8. Is the ice machine connected to a 115 volt electrical power supply and is the ice machine the only load on that circuit?
9. Has all of the shipping material been removed from the inside of the cabinet?
10. Has the bin and cabinet been wiped clean and sanitized?
11. Has the Customer Evaluation & Warranty Registration form been properly filled out? Check for correct model and serial numbers from the nameplate, then mail the completed form to Scotsman.
12. Has the owner/user been given the name and telephone number of the authorized Scotsman Service Agency serving that location?

Component Location

Many components are serviceable from the front without removing the side panels.

Behind the front panel:

- Water pump
- Inlet water valve
- Reservoir
- Evaporators
- Water distributor pan
- Ice size control adjustment
- ICE/OFF/WASH switch
- Control box

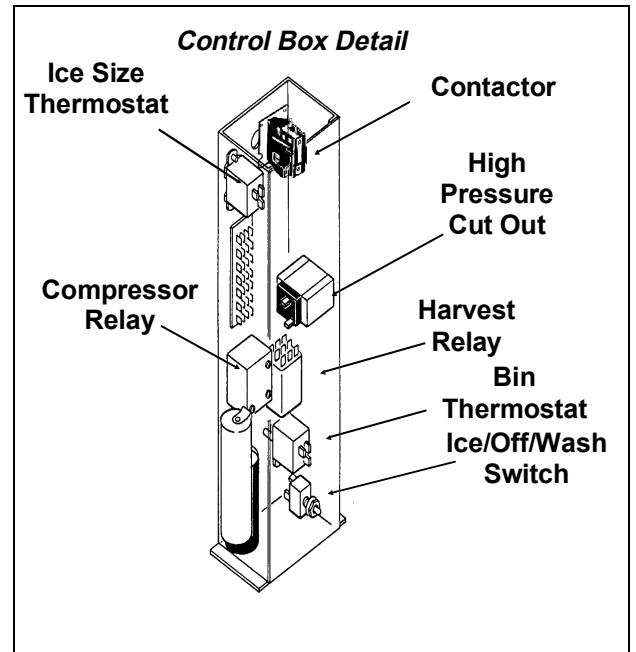

Ice Thickness Control

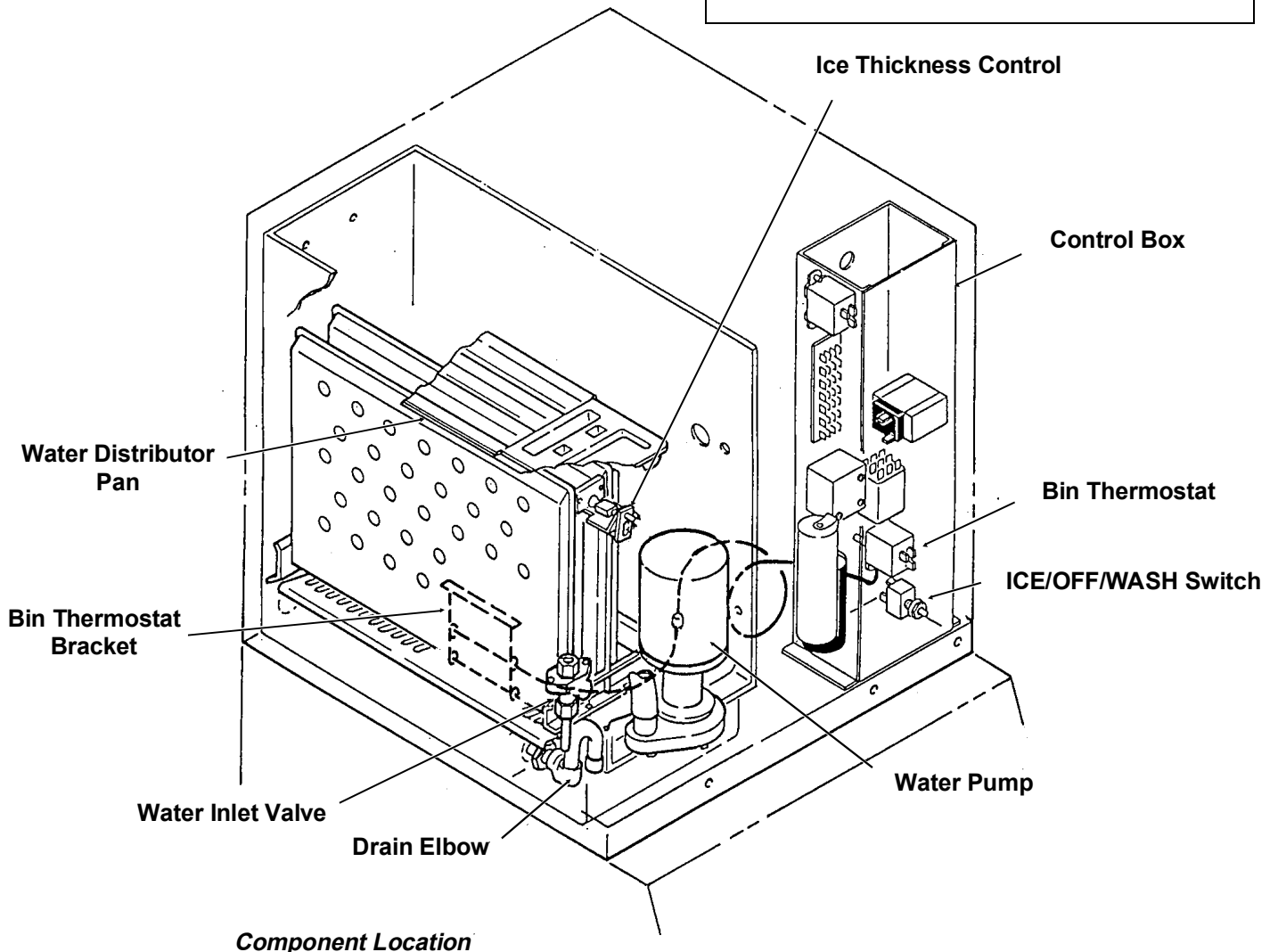

Component Location

SLE400

Initial Start Up

After the final check list has been gone through, the ice machine may be started up.

1. Open the water shut off valve; the inlet water valve will open, and water will flow into the reservoir..
2. Switch on the electrical power.
3. Remove the front panel.
3. Locate the ICE/OFF/WASH switch, switch it to WASH.
4. The water pump will begin to pump water over the evaporators.
5. Allow the reservoir to refill. Normal water level is 1/8" below the high point of the lower curve of the siphon u-tube.
6. Switch the ICE/OFF/WASH switch to OFF.
7. Check the action of the siphon. The water level in the reservoir should drop to the bottom curve of the U-bend (normal water level) in about 2 minutes. If not, check for proper drain tube connections.
8. Switch the ICE/OFF/WASH switch to ON.
9. On air cooled models the fan motor will begin to turn, and warm air will be discharged from the back of the ice machine.

On water cooled models warm water will begin to flow from the condenser drain.

10. The water temperature in the reservoir will soon be 32⁰F., and ice should begin to form on the evaporators.

11. Allow the ice machine to operate for about 15-20 minutes. The ice should be fully formed and should be harvested within a few minutes.

12. After harvest, check the ice cube size.

Compare a fresh cube to the diagram on the back of the front panel. If needed, adjust the cube size by loosening the set screws and moving the ice thickness probe adjustment plate.

Move the adjustment plate down for smaller cubes and up down for larger.

For proper operation, the ice thickness should be set to the 1 1/16" diameter.

The machine is designed to harvest cubes of only the correct thickness.

Ice Size Adjustment

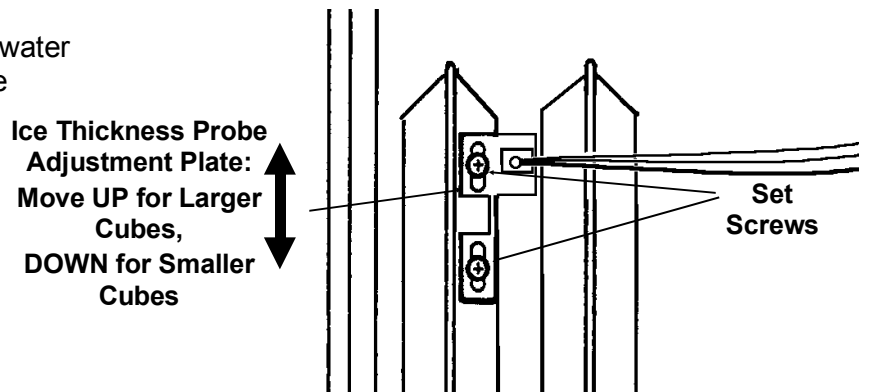

Cube Size Diagram

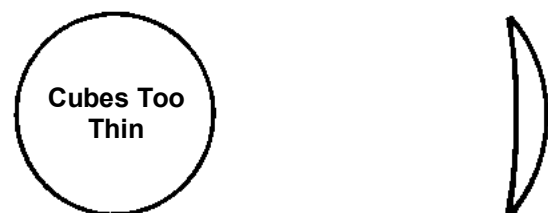
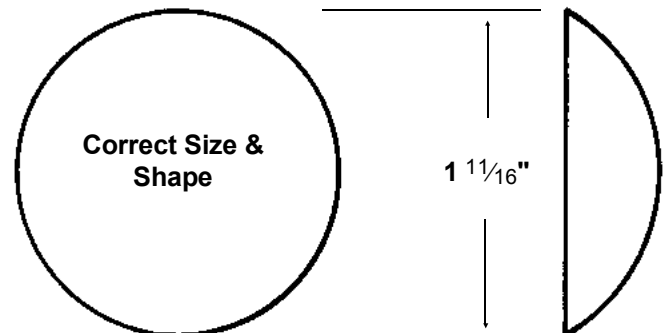
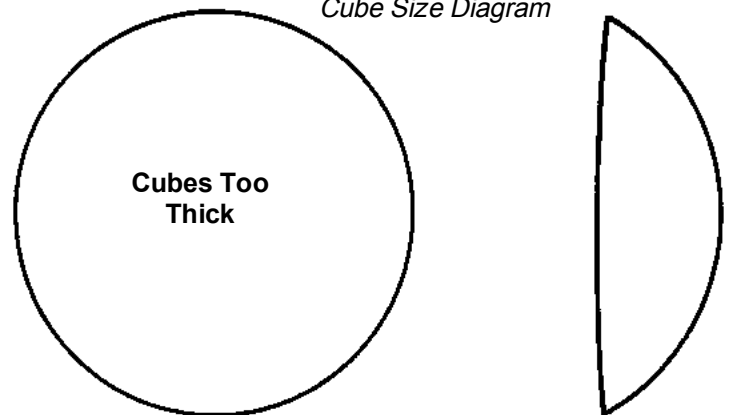

Initial Start Up

Note: If the first batch of cubes are not all uniform discs, some ice machine cleaner should be added to the reservoir.

1. After ice has been harvested, but before new cubes begin to form, switch the ICE/OFF/WASH switch to WASH.
2. Add 4 oz. of ice machine cleaner to the reservoir. Allow unit to operate that way for 10 minutes.
3. Switch ICE/OFF/WASH switch to OFF
4. Shut the water supply off.
5. Remove the splash guard, and drain the reservoir by removing the drain elbow.
7. Replace all parts, turn on the water and move ICE/OFF/WASH switch to ICE. The next batch of ice should be uniform.
13. Check harvest. The machine will have to harvest all of the cubes before it goes back into the freeze cycle.
14. Check operation of the bin control circuit by holding ice on the bin control tube in the bin.

If the ice maker does not stop within 1 minute, while keeping ice on the thermostat, rotate the bin thermostat shaft counter clockwise until the ice maker does stop. Remove the ice from the capillary tube; the ice maker should restart within 2 minutes. If it does not, rotate the adjusting shaft clockwise until the machine starts.

15. Replace all the panels. The ice machine is now ready for automatic operation.

Siphon Tube Schematic

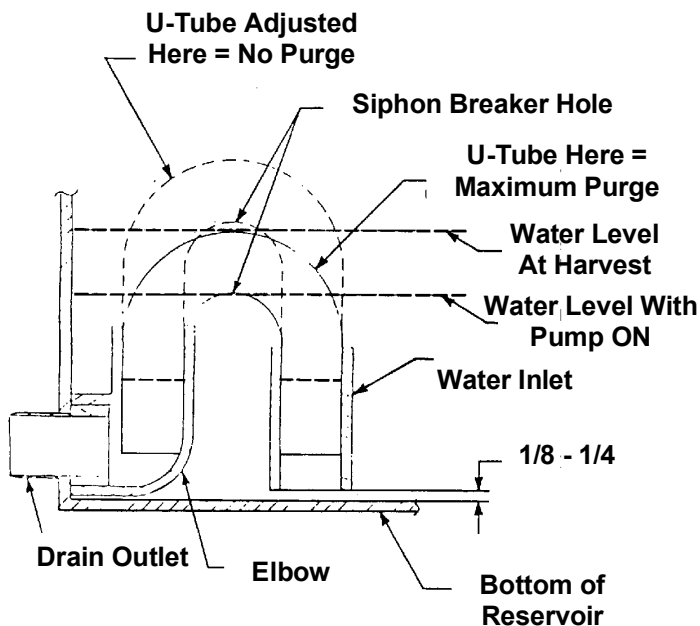

Electrical Sequence:

Freeze Cycle:

During the first part of the freeze cycle, the ice machine compressor, fan motor if air cooled, and water pump are operating.

Assume the bin thermostat is open (low ice), relay K1 will NOT have power thru its coil and K1 contacts 6-2 will be closed, connecting power to the ice size thermostat.

The ice size thermostat contact 2-3 are closed, connecting power to the fan and pump motors.

The Harvest Termination Thermostat is closed to NC, but there is no power thru it.

The ice size thermostat heater is on, and the compressor contactor coil is energized.

Harvest:

In the harvest cycle, the compressor is operating, and the hot gas valve is energized. The water pump is off, and air cooled models switch the fan off. The bin thermostat is still open.

When the ice near the ice size thermostat sensing tube grows large enough to force water over the sensing tube, that tube loses heat, and at 38°F. contacts 2-3 open and 2-1 close.

This removes power from the water pump and fan and connects power to the relay coil. When the relay coil has power, it connects power to the:

- Hot gas valve coil

The harvest termination switch is closed, and power flows thru it to the relay coil. This keeps the relay energized, even when the ice size thermostat switches contact position as a result of ice falling away from the sensing tube.

The unit stays in the harvest cycle until the thermodisc on the suction line warms up to 55°F., at that time the defrost thermodisc switches to NO and the harvest cycle is terminated. If the bin thermostat is still open, relay K1 will still not have power and the unit will go back into the freeze cycle. If relay K1 has power, it shuts off the ice machine by cutting power to the ice size thermostat. The ice size thermostat heater is on.

Whenever there is ice on the bin thermostat, it closes a circuit to the coil of relay K1 and stops the ice making process at the end of a harvest cycle.

SLE400

Maintenance, Cleaning and Sanitizing

Cleaning Schedule:

- Scrub the outside of the cabinet once a week with soap and water.
- Sanitize the bin interior once a month.
- Clean the water system and air cooled condenser a minimum of twice per year. If in an area of high mineral concentration in the water supply, clean water system 4 times a year.

Air Cooled Condenser (air cooled only):

Remove the right side panel.

The air flow thru the condenser is from front to back, so dust will build up on the fan side of the condenser fins.

The fan motor, bracket and part of the shroud may be removed as an assembly.

1. Shut the unit off.
2. Remove the right side panel.
3. Unplug the fan motor.
4. Remove three screws at right edge of shroud.
5. Pull shroud and fan out as an assembly, the inside fins of the condenser are now visible for cleaning.

The fins of the condenser will become fouled with dirt, and must be cleaned. A vacuum cleaner with a soft brush attachment will extract most loose dust stuck to the surface of the condenser fins..

Water Cooled units:

The water cooled condenser may, over time and under certain water conditions, become internally restricted by minerals. These will have to be dissolved by acid or the condenser replaced. Only a qualified service agent should attempt this type of service.

Ice Storage Bin

The interior liner of the bin is in contact with a **food** product: **ice**. The storage bin must be **cleaned** regularly to maintain a **sanitary** environment. Once a week cleaning with soap and water, a hot water rinse and an air dry is a basic procedure.

Every 30 days, the liner should be sanitized with a commercial ice machine sanitizer, according to the directions of the sanitizer, or with a solution of household bleach and water:

1. Mix the bleach and water using the ratio of two ounces of bleach to two gallons of water.
2. Wipe all interior surfaces of the ice storage bin with the bleach and water.
3. Allow to air dry.

To Remove Scale:

1. Mix a cleaning solution of 4 ounces of Scotsman Ice Machine Cleaner to 4 pints of warm (95⁰F.-110⁰F.) water.
2. Using rubber gloves, dip a nylon scouring pad into the cleaning solution and scrub the scale off the liner.
3. After the scale has been removed, rinse all surfaces inside the bin with clean, potable water.

Stainless Steel Bin Liner

The stainless steel liner of the bin will require periodic cleaning. Chemicals in the water supply, such as chlorine, cause brown stains to appear on the surface of the stainless steel parts.

1. General Cleaning - staining is usually removed by washing the parts with ordinary cleaning powder such as Bon-Ami or Copper-Glo and water. After cleaning, rinse with clear water.
2. Water treatment. The chlorine enters the machine from the municipal water supply. It can be removed from the water supply by using a charcoal or activated carbon water filter to treat the water to the ice machine. If staining is severe, filters of this type are recommended.

Exterior Cabinet Cleaning:

The exterior cabinet may be cleaned by scrubbing with soap and water. Do not use cleaners containing petroleum products.

A nylon type brush may be used to scrub stubborn deposits.

Cleaning: Ice Machine Water System

Dissolve and Remove Minerals:

1. Remove front panel.
2. Move the ICE/OFF/WASH switch to OFF.
3. Remove the splash guard.
4. Shut the water supply off.
5. Drain the water from the sump by removing the drain elbow.
6. Disconnect hose from the water distributor pan, and remove the water distributor pan.
7. Mix a solution of 5 oz. ice machine cleaner and 1 gallon of warm (95°F. - 115°F.) water.

Scotsman Ice Machine Cleaner contains acids. These compounds may cause burns.

If swallowed, DO NOT induce vomiting. Give large amounts of water or milk. Call Physician immediately. In case of external contact, flush with water.

KEEP OUT OF THE REACH OF CHILDREN.

⚠ WARNING

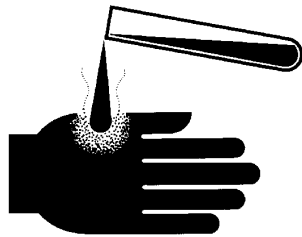

8. Wash the splash guard, drain elbow and water distributor pan with the ice machine cleaner/water solution.
9. With the solution of ice machine cleaner and water, wash the refrigeration tubing, liner, evaporators, support brackets and the water pump assembly. Use the brush and/or a clean cloth.
10. Replace the drain elbow.
11. Open the water supply and allow the sump to refill.
12. Add 5 oz. ice machine cleaner to the sump area.
13. Replace the water distributor pan and splash guard. Be certain the hose to water distributor pan is connected to pan.
14. Move the ICE/OFF/WASH switch to wash and allow the solution to circulate for 15 minutes, then move the ICE/OFF/WASH switch to OFF.
17. Remove the splash guard.

15. Shut the water supply off.
16. Drain the water from the sump by removing the drain elbow.

Sanitize:

17. Remove the water distributor pan.
18. Mix a sanitizer solution of 1 ounce of household bleach to 2 gallons of warm (95°F. - 115°F.) water
19. Wash the splash guard and the water distributor pan with the solution of sanitizer. Allow to air dry.
20. With the sanitizer solution, wash the refrigeration tubing, liner, evaporators, support brackets and water pump assembly; use the brush and/or a clean cloth.
21. Replace the water distributor pan and splash guard. Be certain that the hose to the water distributor pan is tightly connected to the pan, and that the flow washer in the hose is not in sideways.
22. Replace the drain elbow.
23. Add ice machine sanitizer solution to the sump area until it is full.
24. Move the ICE/OFF/WASH switch to WASH add more sanitizer solution to the sump area until it is full again.
25. After 5 minutes, move the ICE/OFF/WASH switch to OFF.
26. Remove the splash guard.
27. Drain the water from the sump by removing the drain elbow.
28. Replace the drain elbow and splash guard
29. Open the water supply and allow the sump to refill.
30. Move the ICE/OFF/WASH switch to ICE.
31. Replace the front panel.
32. Discard first batch of ice and all other batches until all traces of cleaner and sanitizer disappear.

SLE400

Refrigeration Schematic:

Freeze Cycle:

From the compressor, hot discharge gas is pumped to the condenser, either air or water cooled.

At the condenser, heat from the refrigerant flows into the cooling medium, either air or water, and the refrigerant condenses into a liquid. From the condenser the liquid refrigerant flows through the liquid line to the metering device - a thermostatic expansion valve.

At the expansion valve, the liquid refrigerant passes from a high pressure zone to one of relatively low pressure, and in the low pressure zone it evaporates. The low pressure zone where the refrigerant evaporates is the evaporator. When the refrigerant evaporates, it absorbs heat from the metal parts of the evaporator and the water flowing over it.

From the evaporator, the refrigerant flows back to the compressor through the suction line.

Water Schematic:

Water flows into the ice machine from its inlet connection at the back of the cabinet, through the inlet water valve and into the reservoir. The water in the reservoir is pumped up and through the water distributor tube at the top of the evaporators. From there, the water flows over both sides of the evaporators and back into the reservoir.

Melted ice and water spills into the bin flow through a drain in the base of the bin to the exterior drain connection at the back of the cabinet.

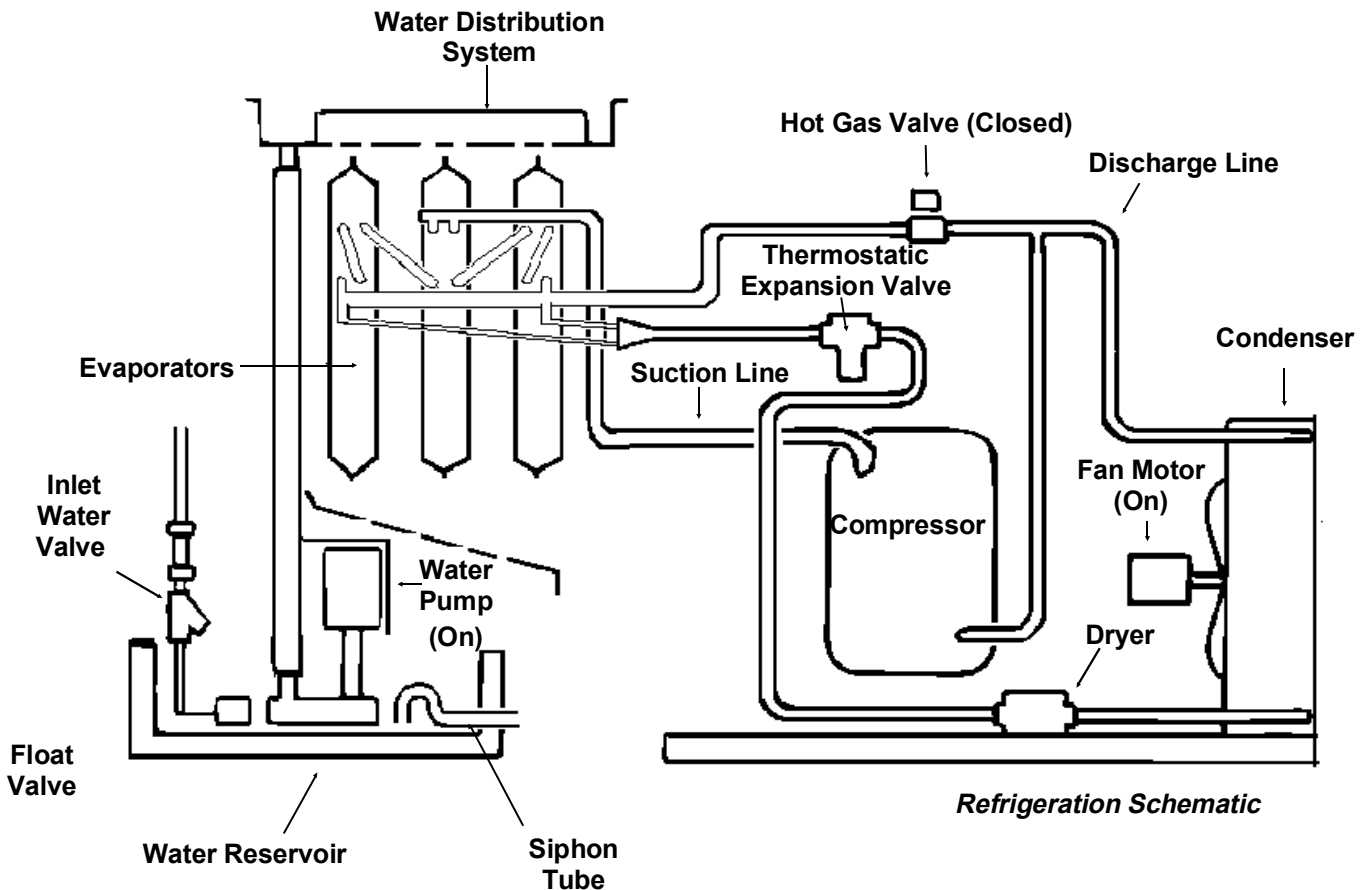

Harvest Cycle:

The ice maker continues to freeze the water into ice until the ice next to the ice size thermostat probe has become thick enough to force water over the probe. After the cold water has reduced the temperature of the probe to 38°F., the ice size thermostat will switch the machine into the harvest cycle.

During the harvest cycle, the refrigerant flows from the condenser, through the discharge line to a branch in the line containing the Hot Gas Valve. This valve is Open during the harvest cycle, allowing the hot discharge gas to bypass the condenser and enter the evaporator at its inlet.

The hot discharge gases warm up the evaporator enough to allow the surface of the ice frozen to the evaporator to melt. The remaining ice will then fall off into the bin.

During the Harvest Cycle, the water level rises, filling the reservoir over the siphon tube and siphoning some of the reservoir water out to the drain.

The harvest cycle continues until the suction line warms up enough to cause the harvest termination thermostat to switch the machine back into the freeze cycle.

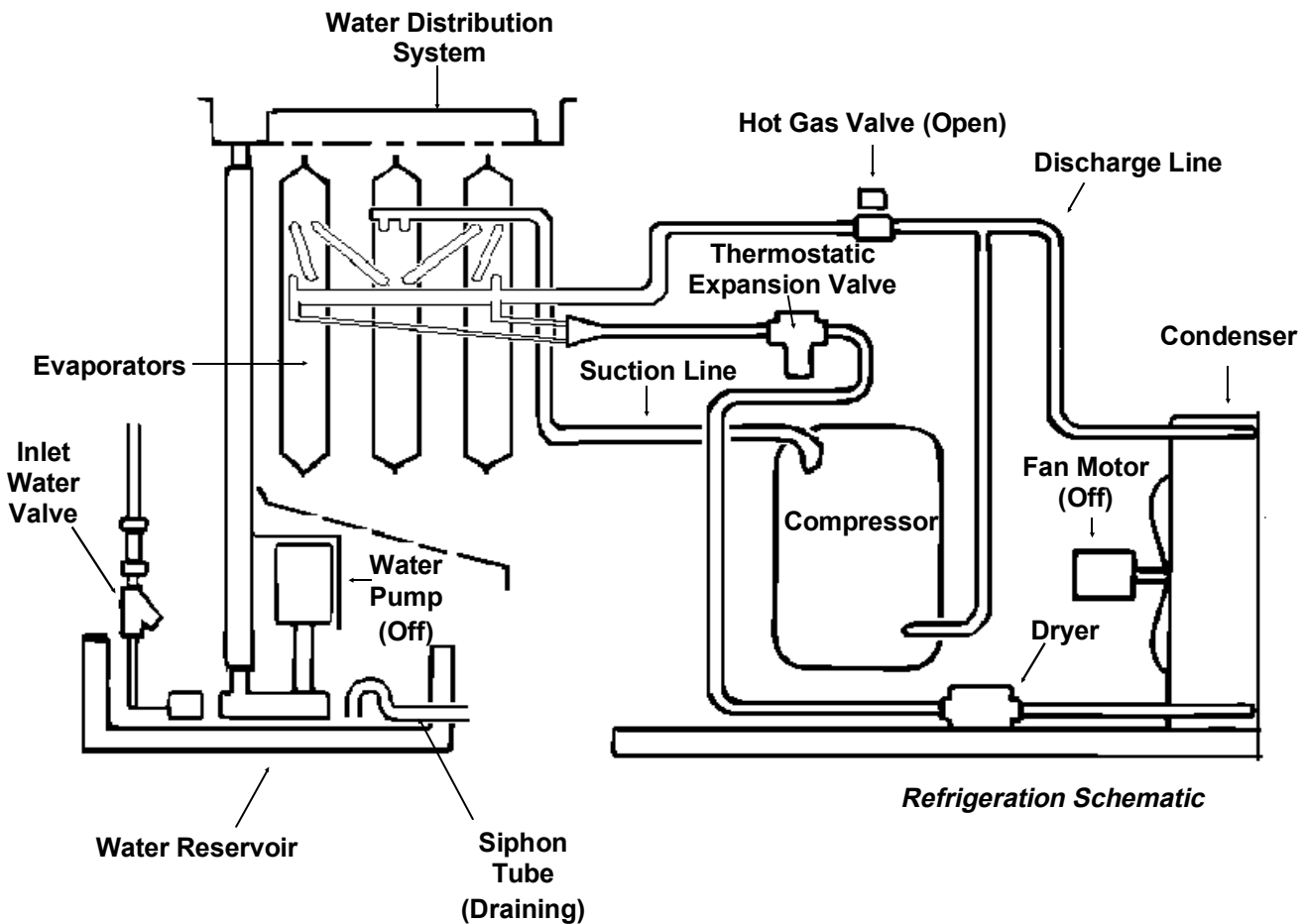

SLE400

Technical Characteristics

Typical Cycle Time

- 16 - 17 minutes @ 90°F. air and 70°F. water

Typical Harvest Ice Weight

- 3.8 - 3.9 pounds .

Typical Low Side Pressure 8 minutes into freeze

- 22 PSIG @ 70° F. air
- 31 PSIG @ 90° F. air
- 36 PSIG @ 100° F. air
- 22-27 for water cooled

Typical Freeze Cycle Discharge Pressure

- 226 PSIG @ 70° F. air
- 290 PSIG @ 90° F. air
- 370 PSIG @ 100° F. air
- 270 for water cooled

Refrigerant Charge:

- Air cooled = 19 ounces R-404A; Water cooled = 18 ounces R-404A

Harvest Time

- Normally 1½ to 2 minutes. Depends upon time required to warm suction line to 55°F.

Typical Suction Pressure, In Harvest:

- PSIG

Typical Discharge Pressure, In Harvest:

- PSIG

High Pressure Cut Out

- Cuts out at 380 PSIG, resets at 315 PSIG

Thermostatic Expansion Valve

- Superheat is 3° - 6°F.

Ice Size Thermostat:

- Switches to harvest cycle with temperature fall to 38°F.. Resets at 43°F.

Ice Size Heater

- Adds heat to ice size thermostat to prevent premature harvest. 6,000 ohms resistance.

Harvest Termination Thermodisk

- Switches from contacts C-NC to contacts C-NO at a temperature rise to 55°F. At that point the machine returns to the Freeze Cycle or switches OFF. The thermodisk resets at 40°F.

Service Diagnosis:

SYMPTOM	POSSIBLE CAUSE	PROBABLE FIX
No ice is made, nothing operates	Unit off, due to no power	Restore power
	Unit off, due to ICE/OFF/WASH switch in OFF position	Switch ICE/OFF/WASH switch to ICE
	Unit off, due to bin thermostat closed	Check temperature at bin thermostat bracket, if warmer than 40° F., thermostat should be closed. Adjust/replace thermostat.
	Unit off, due to relay K1 coil open	Check relay K1, replace if coil is open.
	Water cooled unit off, due to high pressure cut out open	Lack of water to condenser, check water supply and water regulating valve.
No ice, compressor off	No cooling due to compressor not operating	Check compressor for voltage, continuity, and operation. Check starting components. Replace if found to be faulty.
		If no voltage, check contactor, replace if coil or contacts open.
		Check temperature of compressor, if hot may be lack of refrigerant, defective TXV or compressor
No ice is made, compressor is operating	No water due to water turned off.	Reconnect water supply
	No water due to water filter plugged.	Replace water filter
	No water due to strainer screen plugged	Clean out inlet screen
	No water due to inlet water valve will not open	Replace valve
	Water in reservoir, but no water over evaporators	Water pump does not work, replace pump
	No cooling at evaporator due to hot gas valve leaking thru	Replace hot gas valve
	No cooling at evaporator due to fan not turning	Check & replace fan motor.
	Fan and pump do not have power; hot gas valve opens and closes.	Coil or relay open, replace relay.
	No cooling at evaporator due to dirty condenser	Clean condenser
	No cooling due to compressor not pumping	Check system pressures, replace compressor if not pumping

SLE400

Service Diagnosis:

SYMPTOM	POSSIBLE CAUSE	PROBABLE FIX
No ice compressor is operating	No cooling due to low refrigerant charge	Locate leak, recover remaining refrigerant, replace dryer, evacuate and weigh in nameplate charge.
Ice is made, but not harvested.	Ice size thermostat contacts do not switch position	Ice not made near thermostat probe due to water distributor holes restricted. Clean water distributor pan. Thermostat defective, replace it
	Ice will not slide down ice rack due to minerals on rack.	Clean machine with ice machine cleaner.
	Ice will not slide down ice rack due to ice rack out of position	Reposition ice rack
	Ice will not slide down ice rack due to bent ice rack	Replace ice rack
	Lack of heat during harvest cycle due to unit in air temp. less than 55 ⁰ F.	Warm up air or move machine.
	Lack of heat during harvest due to water flowing thru water cooled condenser	Replace water regulating valve
	Lack of heat during harvest due to lack of refrigerant	Check low side pressure during harvest. If low either the charge is low or the hot gas valve does not open fully. If charge is the problem, locate leak, recover remaining refrigerant, repair leak, replace drier, evacuate and weigh in nameplate charge.
	Lack of heat during harvest due to hot gas valve not opening fully.	Check low side pressure during harvest. If low either the charge is low or the hot gas valve does not open fully.
	Ice does not slide down face of evaporator due to minerals on evaporator surface	Clean water system with ice machine cleaner
	Harvest cycle too short due to harvest termination thermostat opens at too low a temperature.	Replace harvest termination thermostat

Service Diagnosis:

SYMPTOM	POSSIBLE CAUSE	PROBABLE FIX	
Ice is made, but will not harvest	Will not harvest due to hot gas valve not opening.	Check for voltage to coil in harvest, if there is voltage replace hot gas valve	
	Slow/incomplete harvest due to hot gas valve not fully open.	Check low side pressure in harvest, replace hot gas valve if too low with correct ref. charge.	
Makes ice, but very little	High discharge pressure, due to dirty condenser; faulty fan motor; not enough water thru water cooled condenser, high water temperatures, water reg. valve set too high.	Check for causes of high discharge pressure and correct.	
	Inlet water temperatures and room ambient very high	Advise user, suggest additional room cooling.	
	Long freeze cycle due to hot gas valve leaking thru.	Check temperature of tubes to and from hot gas valve; there should be a temperature drop across the valve in the freeze cycle. Replace valve if temps are nearly equal.	
	Compressor inefficient	Check/replace compressor	
Cubes are wrong size/shape	Ice size thermostat not adjusted properly	Adjust ice size thermostat; use gauge shipped with machine	
	Freeze cycle too short due to heater open	Check/replace heater on ice size thermostat probe tube.	
	Water system is restricted with minerals	Clean water system with Scotsman Ice Machine Cleaner	
	Ice thickness probe tube covered with minerals	Clean tube with ice machine cleaner	
	Not enough water		Check water supply pressure
			Check water supply for restrictions
	Too much superheat		Check superheat, replace TXV if too high.
Check hot gas valve for leak-thru; replace if leaks thru.			
Ice fused together in bin	Ice in bin too long	Advise user to pour water on ice to ease removal	
	Too many minerals in water	Suggest water treatment to user.	

SLE400

Removal and Replacement

Ice Size Thermostat:

Before replacing the ice size thermostat, it should be positively determined that it is at fault.

1. Disconnect electrical power.

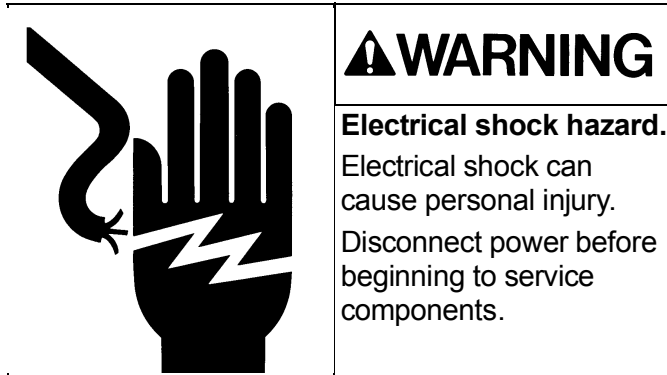

2. Remove the front panel.
3. Remove the control box cover.
4. Locate the ice size thermostat.
5. Remove the two screws holding the control to the control box, and lift the control out.
6. Pull the three wires off the posts of the ice size thermostat.
7. Follow ice size thermostat capillary tube to ice size probe.
8. The end of the ice size thermostat is inserted in a tube. Pull it out of the tube.
9. Follow the capillary tube of the ice size thermostat and pull it thru the insulated wall and the grommet in the side of the control box.
10. Remove thermostat from control box.
11. Replace the ice size thermostat with the proper part number, following the above steps from 9-1.

Primary Resistor (Heater)

1. Disconnect electrical power.
2. Disconnect the primary resistor's yellow wire from terminal #4 and the white wire from terminal #1. Pull the two wires out of the control box and thru the insulated wall.
3. Mark location of probe tube bracket.
4. Remove two screws and the probe tube bracket from the evaporator.
5. Remove the plastic sleeve and heater from the tube.
6. Replace heater and plastic tubes.
7. Place probe tube bracket on evaporator in its original position. Probe tube must be inserted into plastic guide attached to evaporator.

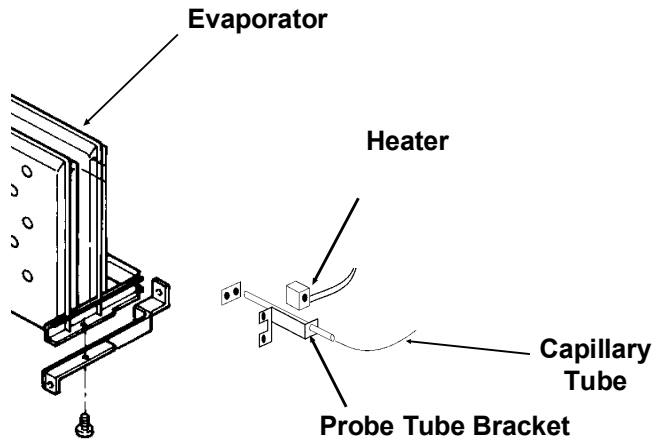

Replacement of Ice Size Thermostat

8. Replace wires.
9. Reconnect power, restart ice maker. Check ice size.

Removal and Replacement

Water Pump

The pump provides the force to move the water from the reservoir to the freezing surface. The pump does not need oil, but if it becomes noisy, overheats, or will not pump it should be replaced. Be certain to confirm electrical faults with a voltmeter or ohmmeter before replacing the pump. The pump should be operating whenever the machine is in the freeze cycle.

1. Unplug or disconnect the electrical power.

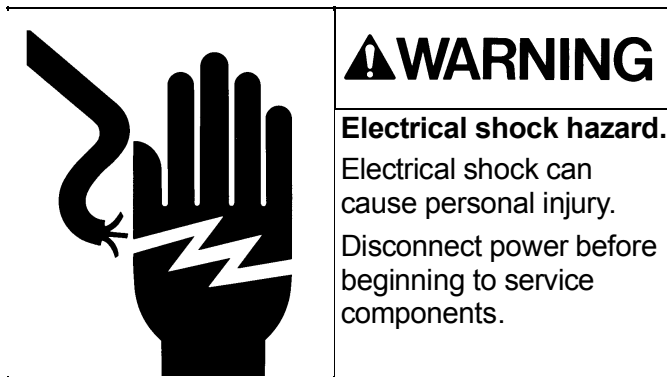

2. Unplug the pump from its connection.
5. Loosen the two fasteners holding the cover to the wall.
6. Remove pump cover from the machine.
7. Pull discharge hose from pump discharge port.
8. Remove pump from ice machine.
9. Reverse above steps to replace.

Inlet Water Valve

The valve may plug-up from minerals in the water, and should then be cleaned rather than replaced. There is also a strainer located above the float valve that may be cleaned.

1. Shut off the water supply.
2. Unscrew the fitting at the top of the valve, and pull the water inlet tube out of the valve body.
3. Remove the screws holding the valve bracket to the liner.
4. Remove the valve from the ice machine.
5. Reverse the above steps to reassemble.

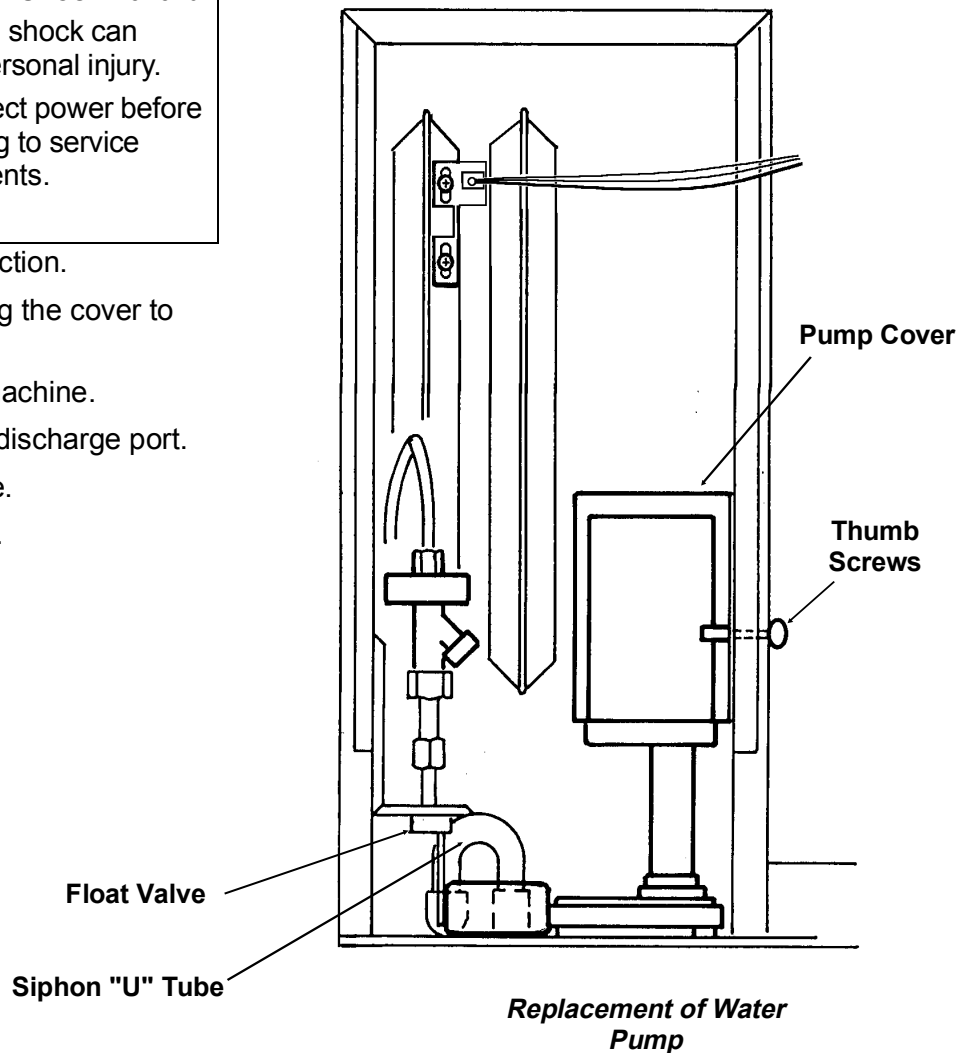

SLE400

Removal and Replacement: Refrigeration System

This ice machine uses R-404A (HP62) refrigerant and polyolester oil. Do NOT use mineral oil in this refrigeration system.

- R-404A is a "Near Azeotrope" so liquid charging is required:
- When the system is serviced, a special liquid line drier is required. It is included with replacement compressors.
- HP62 is not compatible with mineral oil, so these ice machines use Polyolester oil. Polyolester oil absorbs water very easily. When one of these refrigeration systems is opened for service, it must be re-sealed as soon as possible (15 minutes maximum).
- Special leak detection equipment is required to locate small refrigerant leaks. Usually a leak detector capable of detecting a Halogenated refrigerant or HFC-134a will work. Check with the leak detector manufacturer if in doubt.

LIQUID CHARGING Instructions for R-404A

In preparation for charging, the low side hose should have a sight glass, and/or a restrictor device (such as a "Charge Faster") installed in it for metering liquid into the low side of the system.

1. After a thorough evacuation to at least 200 microns, shut off the manifold valves and switch off the vacuum pump.
 2. Place a drum of R-404A onto an electronic scale.
 3. Attach the charging hose to the drum.
 4. Open the valve on the drum and purge the charging hose.
 5. Zero out the scale.
 6. Shut the low side access valve at the ice machine.
 7. Open the discharge manifold valve full open.
 8. Watch the scale, when the correct charge is shown, shut the manifold valve.
- Note: If all of the charge will not "go in" the discharge side:
- A. Shut the discharge access valve at the ice machine.
 - B. Switch the machine on.
 - C. Open the low side access valve at the ice machine.
 - D. Open the low side manifold valve and observe the sight glass to be certain that only gas is flowing into the system.
 - E. When the proper charge is indicated on the scale, shut off the manifold valve(s).
9. Shut off the valve on the refrigerant drum.
 10. Re-open the manifold valves until all liquid has flowed out of the hoses.
 11. Shut the low side access valve on the ice machine.
 12. Remove hoses from ice machine and replace all caps.

Pressure-Temperature Chart for HP62

TEMP. (DEG F)	VAPOR	
	TEMP. (DEG F)	PRESS. (PSIG)
-20	70	146
-18	72	150
-16	74	155
-14	76	161
-12	78	166
-10	80	171
-8	82	177
-6	84	182
-4	86	188
-2	88	194
0	90	200
2	92	206
4	94	212
6	96	219
8	98	225
10	100	232
12	102	239
14	104	246
16	106	253
18	108	260
20	110	268
22	112	275
24	114	283
26	116	291
28	118	299
30	120	307
32	122	316
34	124	324
36	126	333
38	128	342
40	130	351
42	132	360
44	134	370