

# TDE470 Service Parts

This parts lists contains part numbers for the service parts available for the TDE470.

The TDE470 has been manufactured in both 60 Hz and 50 Hz models.

The 60 Hz models are:

- TDE470AE-1A
- TDE470AS-1A

The 50 Hz models are:

- TDE470AE-6A
- TDE470AS-6A

Always check the model number of the ice machine being serviced to be certain that the parts ordered will be correct.

## Table of Contents

Cabinet .....	Page 2
Condensing Components.....	Page 3
Evaporator, Auger, Bearings & Water Seal.....	Page 4
Water And Drain System .....	Page 5
Bin Cover, Dispenser Motor, Electric Eyes .....	Page 6
Gear Reducer and Motor .....	Page 7
Control Box.....	Page 8
Wiring Diagrams.....	Page 9

# TDE470 Service Parts Cabinet

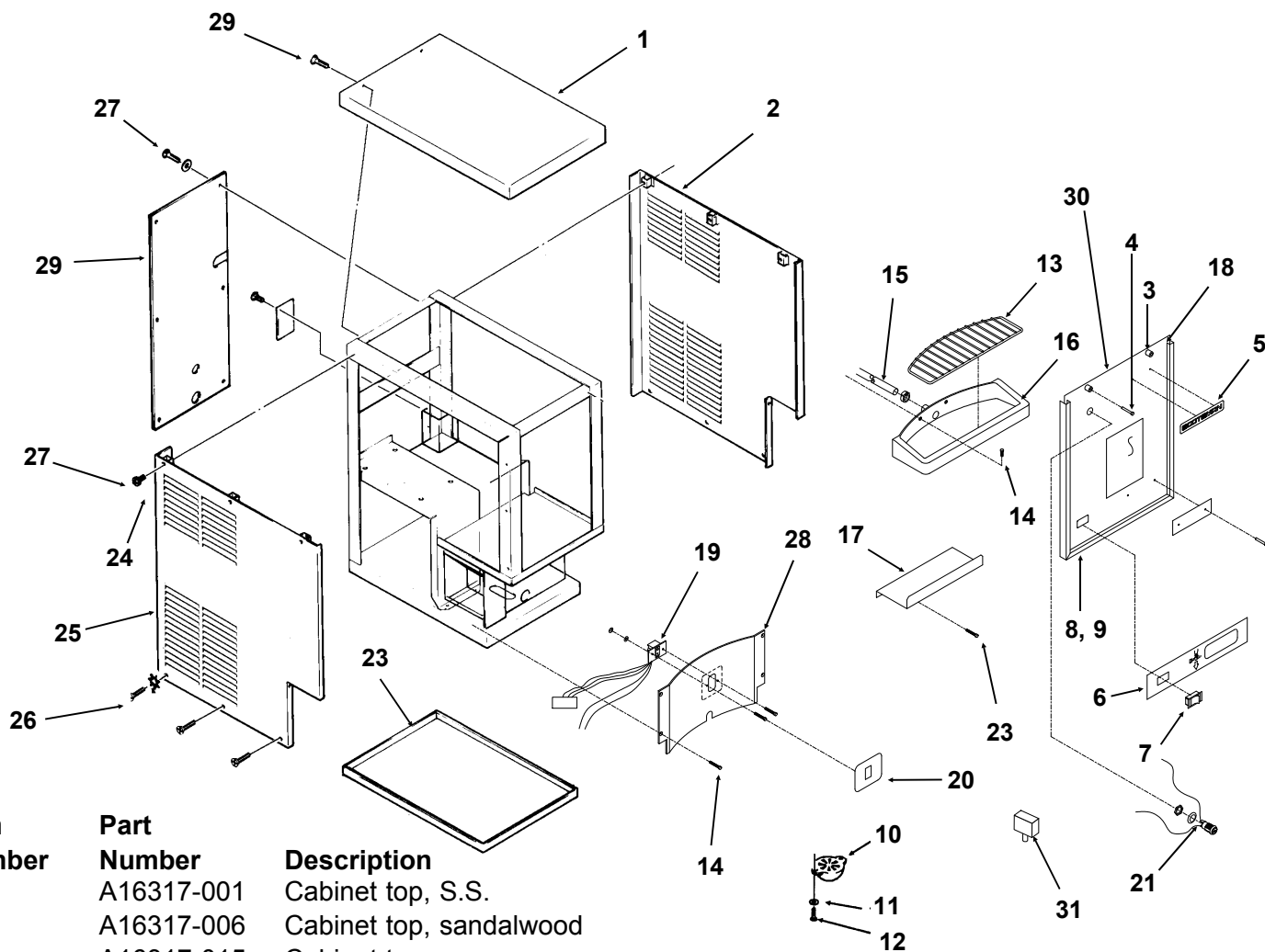

Item Number	Part Number	Description	Item Number	Part Number	Description
1	A16317-001	Cabinet top, S.S.			
	A16317-006	Cabinet top, sandalwood			
	A16317-015	Cabinet top, gray			
2	A21416-001	Right side panel, SS			
	A21416-004	Rt side panel, sandalwood			
	A21416-015	Rt side panel, gray			
3	13-0616-00	Rubber bumper	19	12-2551-20	Touch free sensor
4	03-1404-11	Screw	20	17-2288-06	Decal
5	15-0718-01	Emblem for sandalwood	21	12-2391-01	Lock, Gov't units only
	15-0809-01	Emblem for S.S. or gray	22	03-1360-00	Screw
6	17-2360-01	Touch Free decal	23	13-0566-01	Moulding
7	12-1377-00	Switch	24	03-1417-27	Washer
8	03-1403-15	Screw	25	A21415-004	Left side panel, sandalwood
9	03-1417-27	Washer		A21415-001	Left side panel, SS
10	02-1804-00	Spout		A21415-015	Left side panel, gray
11	03-1407-03	Washer	26	03-1419-27	Screw
12	03-1403-19	Screw	27	03-1404-09	Screw
13	02-3302-01	Grill	28	02-3423-01	Splash panel
14	03-1419-17	Screw	29	A21405-004	Back panel, sandalwood
15	13-0674-07	Tube, order 3 units.		A21405-001	Back panel, SS
16	02-3402-30	Sink		A21405-015	Back panel, gray
17	A35875-001	Bracket	30	A36551-001	Front panel, SS
18	15-0507-00	Moulding trim		A36551-002	Front panel, Gov't units
			31	12-2501-01	Touch Free disable switch

# TDE470 Service Parts

## Condensing Components

Item Number	Part Number	Description
1	18-8741-21	60 Hz compressor
	18-8741-26	50 Hz compressor
2	18-8741-27	Overload for 60 Hz
	18-8741-22	Overload for 50 Hz
3	18-8741-28	60 Hz relay
	18-8741-23	50 hz relay
3	18-8741-29	Start capacitor for 60 Hz
	18-8741-24	Start capacitor for 50 Hz
4	03-1647-01	Screw
	03-1417-12	Washer
	03-1407-07	Washer
	18-4700-28	Grommet
5	18-0108-41	Sleeve
6	16-0832-21	Access valve
6a	16-0832-03	Core cap
6b	16-0832-02	Stem cap
7	18-0422-00	Fan motor bracket
8	18-7200-02	60 Hz fan motor
	18-7200-03	50 Hz fan motor
9	18-8743-01	Fan blade
10	A36094-001	Fan shroud
11	18-8846-01	Condenser
12	02-3319-01	Drier

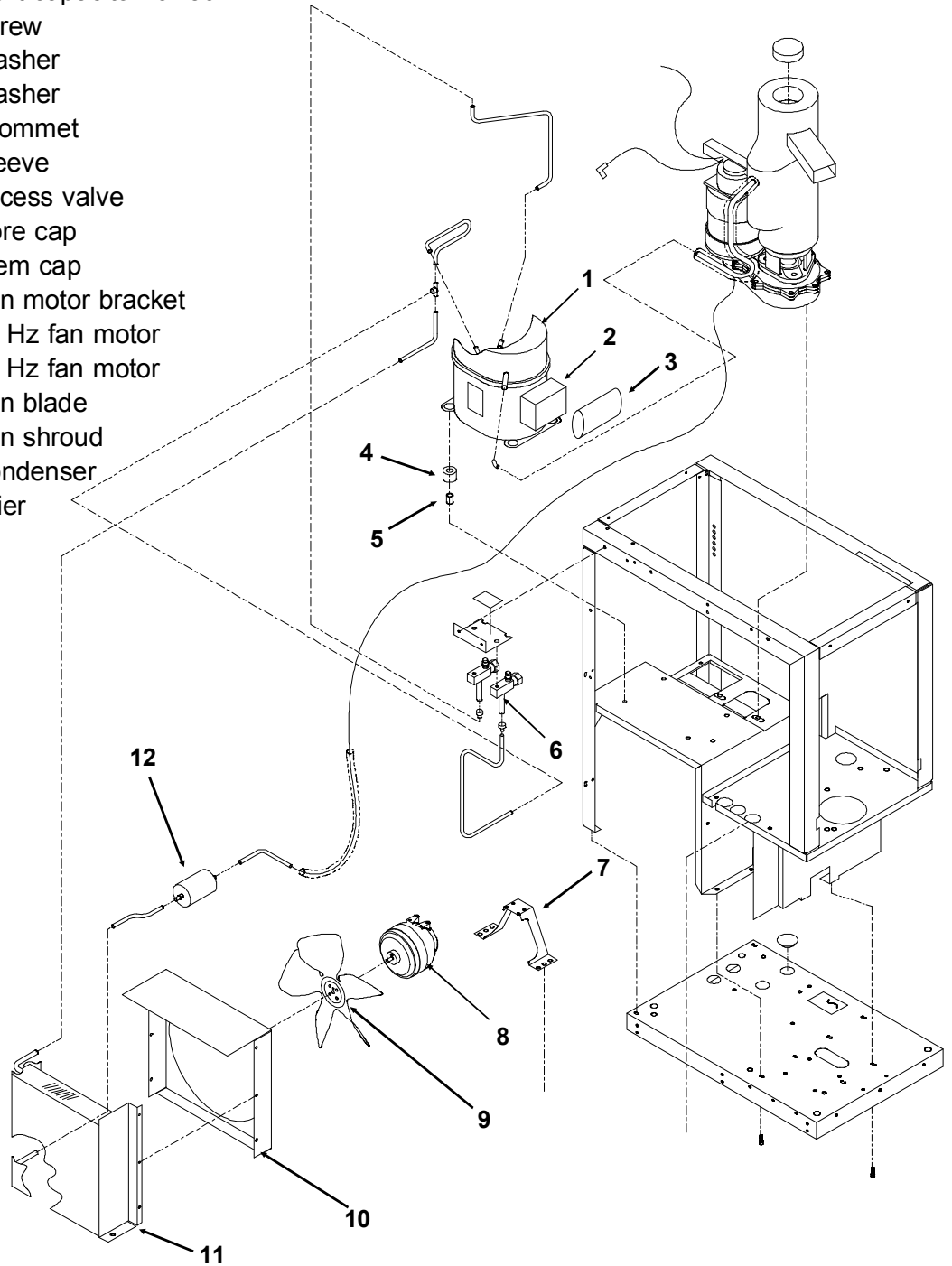

# TDE470 Service Parts

## Evaporator, Auger, Bearings & Water Seal

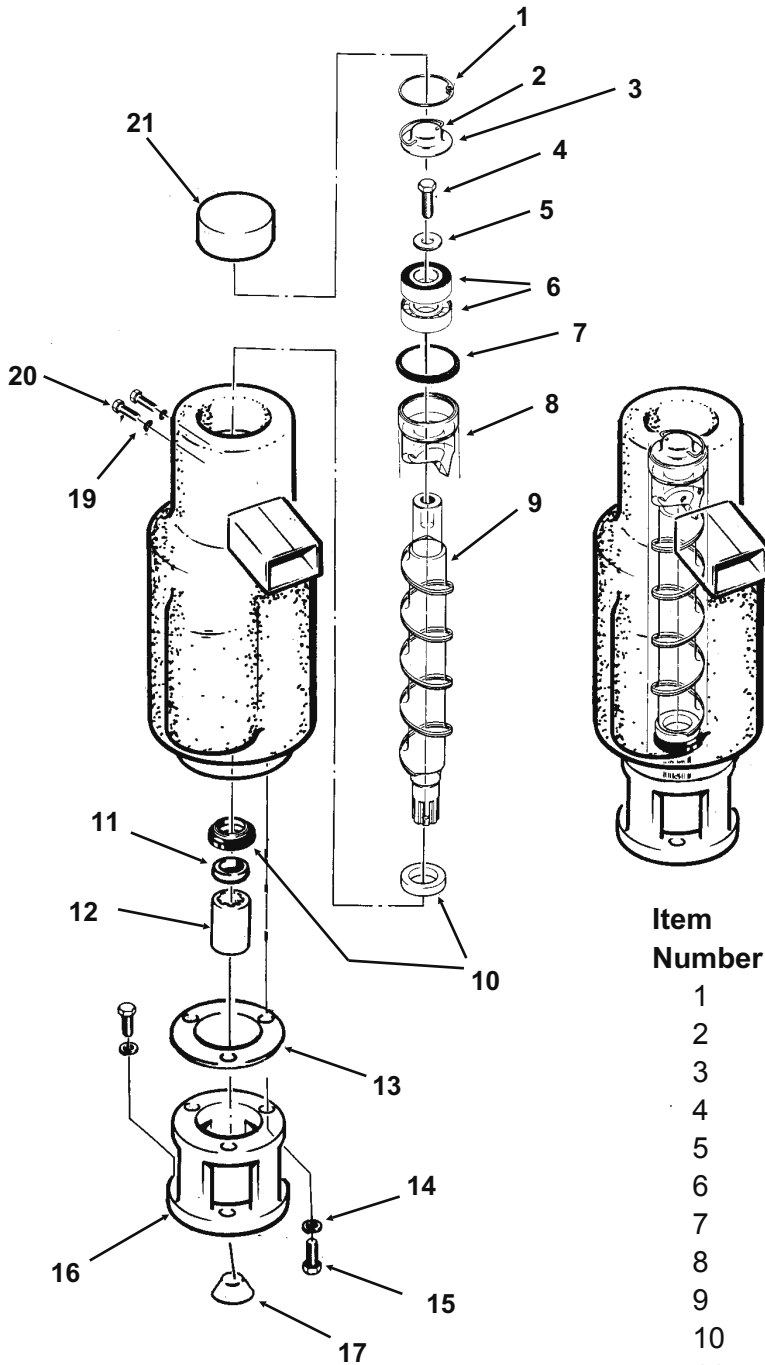

\* Auger and Breaker w/bearing no longer available. Use auger kit 02-4578-02.

Item Number	Part Number	Description
1	03-1558-03	Retainer Ring
2	A08162-000	Cap hook
3	A07701-000	Cap
4	03-0758-00	Screw
5	A07699-000	Washer
6	02-1412-20	Top bearing set
7	13-0617-16	"O" ring
8	A14591-020	Breaker with bearing*
9	02-4023-20	Auger*
10	02-4599-21	Water seal
11	02-0417-21	Bottom bearing
12	A29915-002	Coupling
13	03-1505-00	Gasket
14	03-1410-04	Washer
15	03-1420-01	Cap screw
16	08-0595-01	Adapter
17	13-0709-01	Rubber drip shield
18	A36081-020	Evaporator
19	03-1417-07	Washer
20	03-1403-46	Screw
21	02-4404-01	Cap

# TDE470 Service Parts

## Water And Drain System

Item Number	Part Number	Description
1	A37893-001	Vane Assembly
2	A38272-001	Bin Bottom Assy
3	02-3033-01	Hub Assembly
4	03-1409-22	Fiber Washer
5	A36118-020	Storage Bin
6	13-0895-01	Inlet water line requires 26"
7	03-1394-00	Pal Nut
8	12-1434-04	Water valve (60 Hz)
	12-1434-05	Water valve (50 Hz)
9	16-0869-01	Barbed adapter
10	13-0674-02	Tubing, 12" req.
11	A33101-022	Water sensor
12	02-3402-30	Sink
13	02-3302-02	Grill for sink
14	13-0674-08	Tube, requires 12"
15	02-2814-10	Clamps
16	13-0079-03	Tube, overflow to drain, requires 12"
17	02-2814-08	Clamp
18	02-2814-07	Clamp
19	02-3371-20	Reservoir Assy
20	A36402-001	Reservoir Bracket
21	02-3371-21	Float and arm
21a	02-3266-03	Plunger/seat
22	03-1407-05	Plain Washer
23	03-1645-01	Hex Cap Screw
24	16-0812-01	Tube (to evap.)
25	A21433-000	Inlet fitting
26	16-0870-01	NPT to compr. fitting
27	16-0871-01	Brass insert

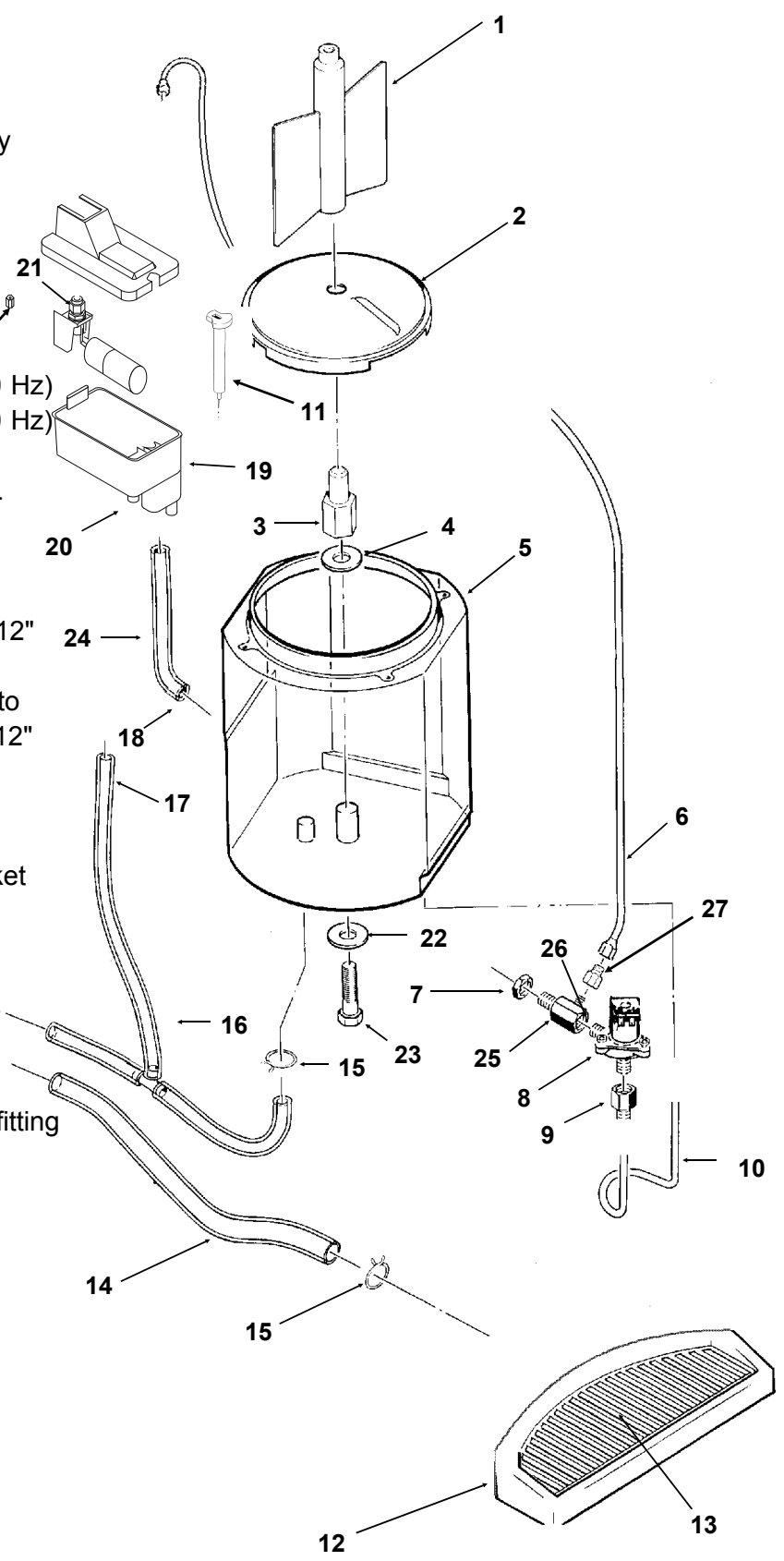

# TDE470 Service Parts

## Bin Cover, Dispenser Motor, Electric Eyes

Item Number	Part Number	Description
1	03-1403-15	Screw
2	03-1531-01	Screw
3	A35474-001	Motor Mtg. Bracket
4	02-3238-01	Bushing
5	03-0727-10	Thumbscrew
6	13-0866-01	Grommet
7	A37710-021	Electric eye set
8	02-3237-01	Bin top
9	02-3239-01	Nut
10	02-3241-01	Shaft
11	12-1610-01	Motor & gears 60 Hz
	12-1610-06	Motor & gears 50 Hz
12	02-1801-02	Strap

A35483-021 Complete assembly 60 Hz (except item 7)  
A35483-026 Complete assembly 50 Hz (except item 7)

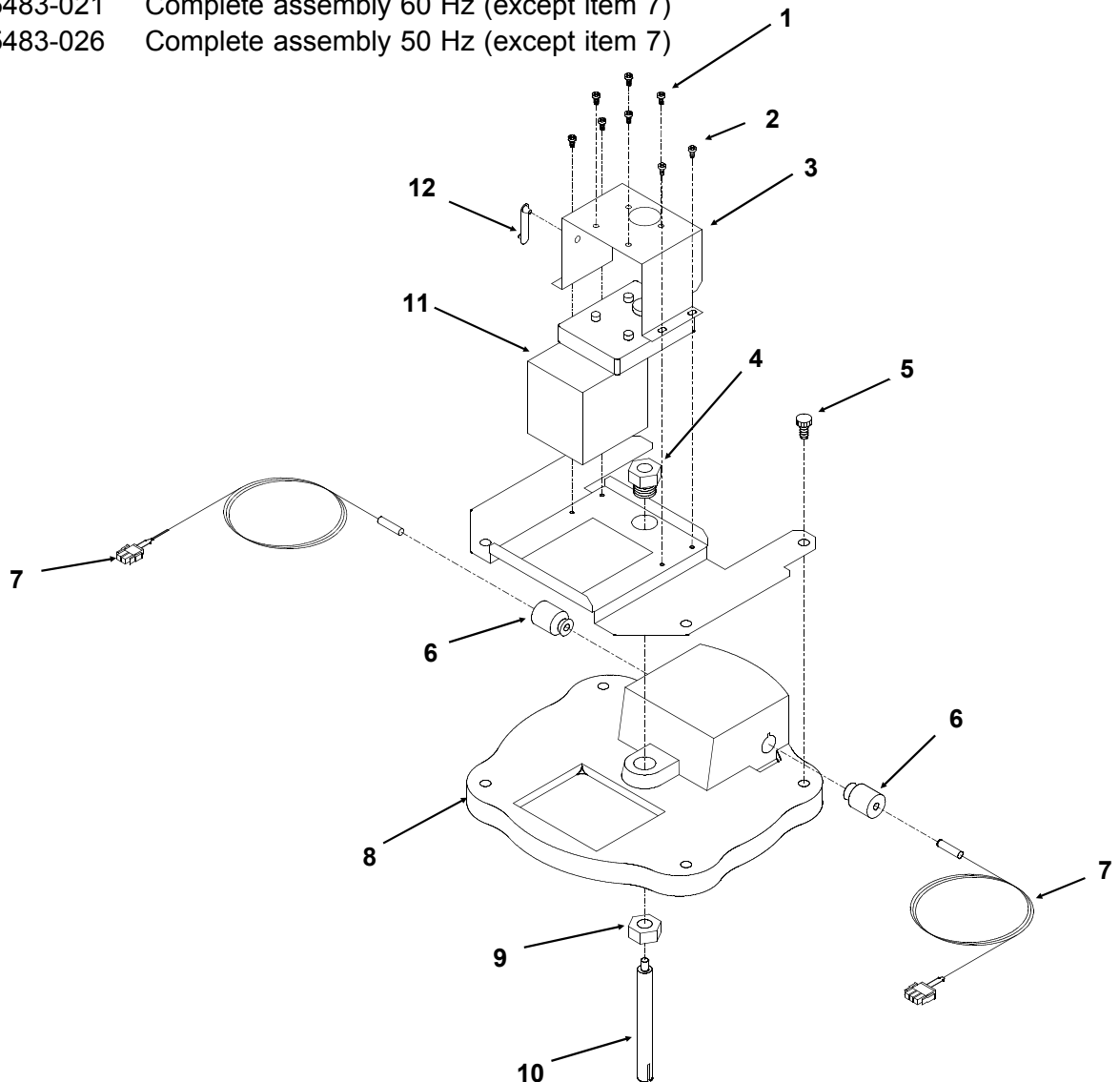

# TDE470 Service Parts

## Gear Reducer and Motor

Item Number	Part Number	Description
1	A27494-001	Centrifugal switch kit
2	12-2059-01	Switch
3	A27494-001	Housing
4	03-1403-77	Screw
5	A30579-001	Shaft & actuator
6	03-1408-36	Washer
7	A38487-001	Motor housing
8	A28168-001	Cooling fan
9	A37707-021	Motor kit, 115/60/1
	A38501-001	Motor kit, 50 Hz
10	no number, part of item 9	
11	03-1408-08	Washer
12	02-1501-00	Bearing
13	02-3969-20	Grease seal (input)
14	02-1503-00	Grease seal (output)
	13-0941-01	Water shed, not shown
15	A28165-021	Gear case cover
16	03-1408-21	Washer
17	03-1408-04	Washer
18	02-2445-01	Output shaft
19	03-1515-03	Retaining ring
20	03-1602-01	Woodruff key

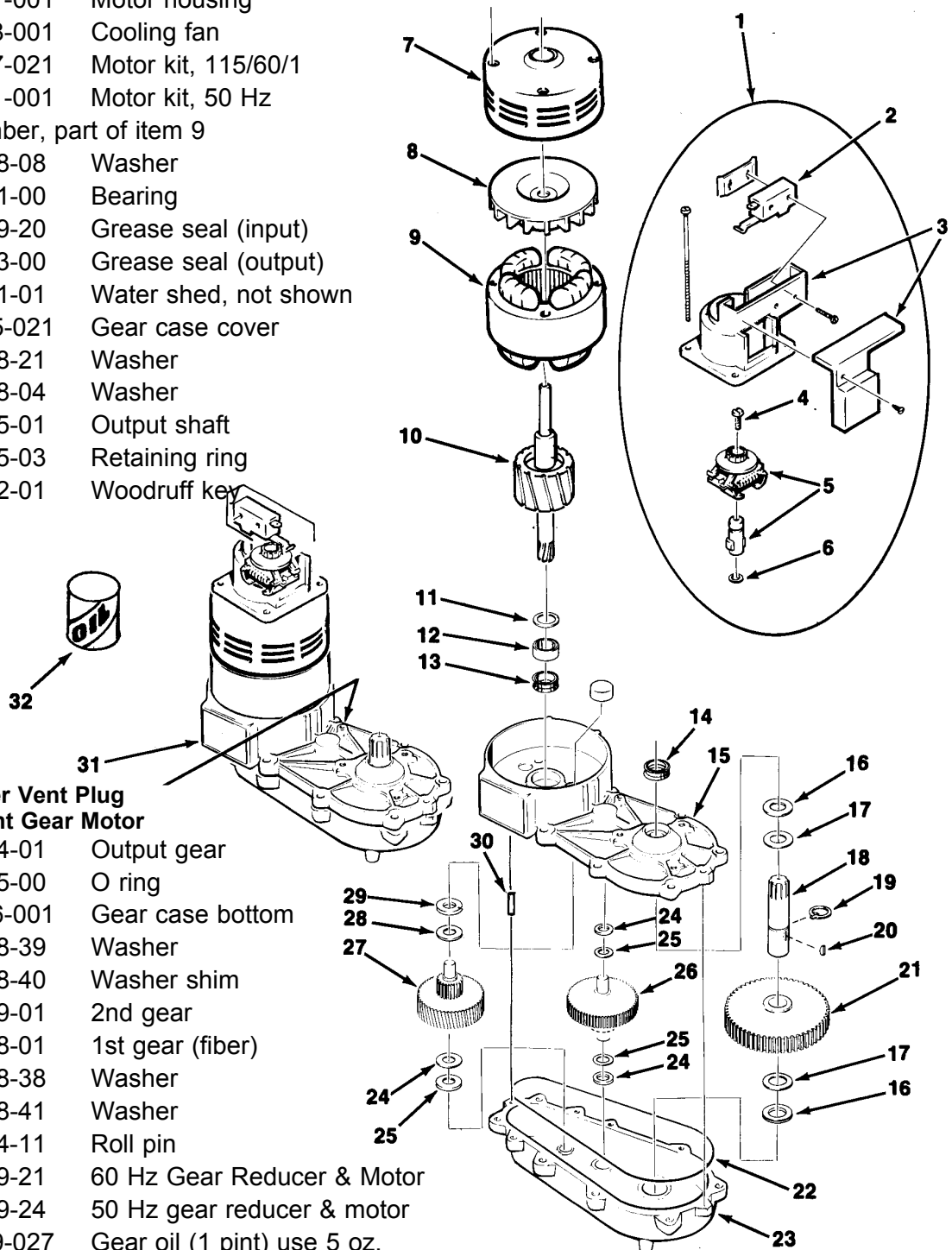

**Remove Rubber Vent Plug From Replacement Gear Motor**

21	02-2444-01	Output gear
22	02-1505-00	O ring
23	A28166-001	Gear case bottom
24	03-1408-39	Washer
25	03-1408-40	Washer shim
26	02-2439-01	2nd gear
27	02-2438-01	1st gear (fiber)
28	03-1408-38	Washer
29	03-1408-41	Washer
30	03-0774-11	Roll pin
31	02-4399-21	60 Hz Gear Reducer & Motor
	02-4399-24	50 Hz gear reducer & motor
32	A32379-027	Gear oil (1 pint) use 5 oz.

# TDE470 Service Parts

## Control Box

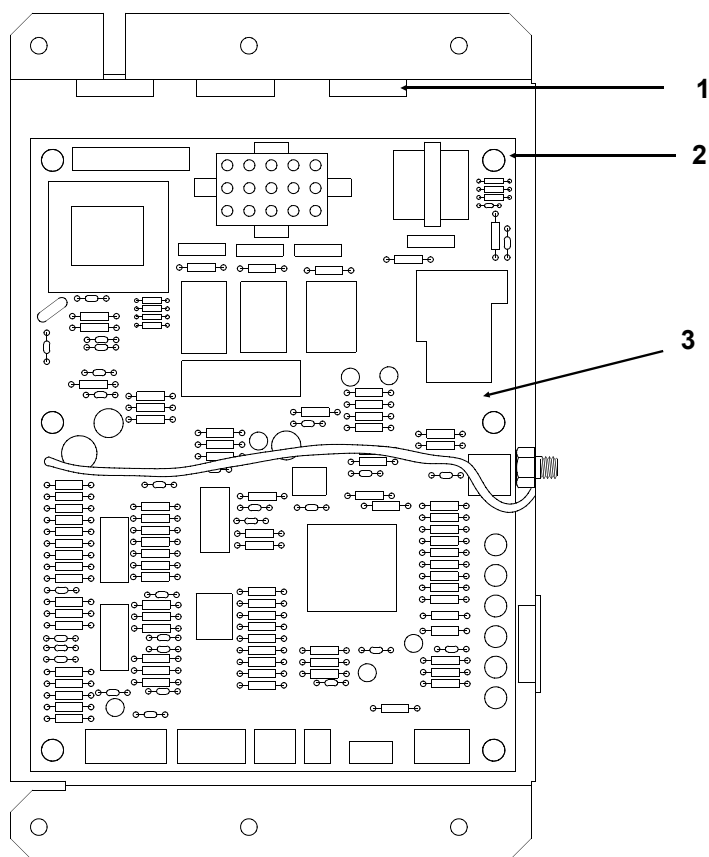

Item Number	Part Number	Description
1	12-1213-10	Snap bushing
2	12-2499-01	Stand off
3	12-2843-21	Circuit board for 115/60/1
	12-2843-26	Circuit board for 220/50/1
	12-2549-01	Board harness (not shown)

**Not Shown: Sink Extension Kit, KDE1A and KDE1A-SS**

1	17-2288-05	Ice Label
2	02-2809-01	Drain top
3	A18331-000	Drain fitting
4	02-1699-00	Sink
5	02-1701-00	Grill
6	02-3446-01	Splash panel
7	13-0617-11	O-ring
8	A21538-000	Base support - enamel
	A21538-001	Base support - stainless steel



# TDE470 Service Parts Wiring Diagram TDE470AE-1A

A36522-001

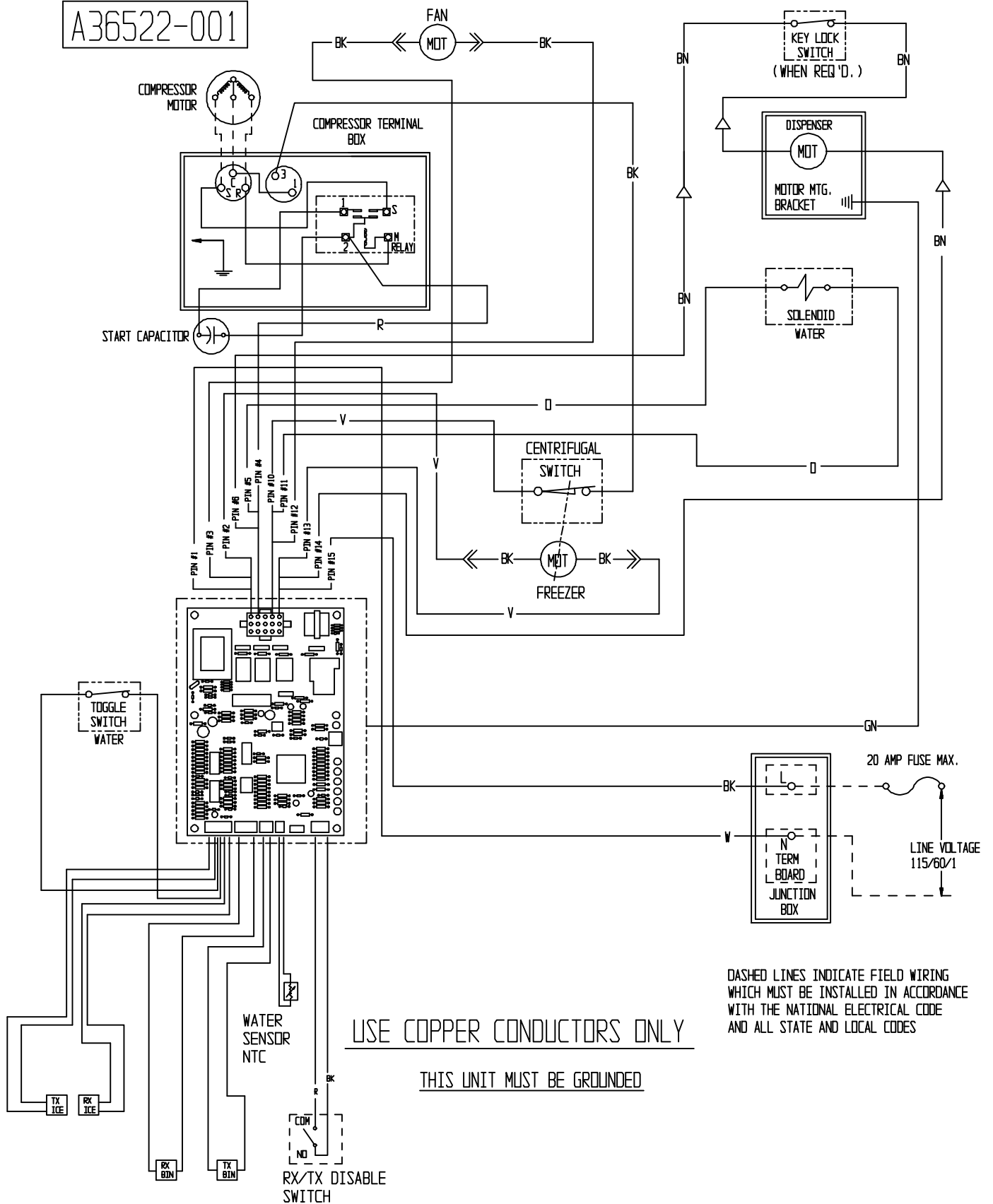

USE COPPER CONDUCTORS ONLY

THIS UNIT MUST BE GROUNDED

DASHED LINES INDICATE FIELD WIRING WHICH MUST BE INSTALLED IN ACCORDANCE WITH THE NATIONAL ELECTRICAL CODE AND ALL STATE AND LOCAL CODES

# TDE470 Service Parts Schematic Diagram TDE470AE-1A

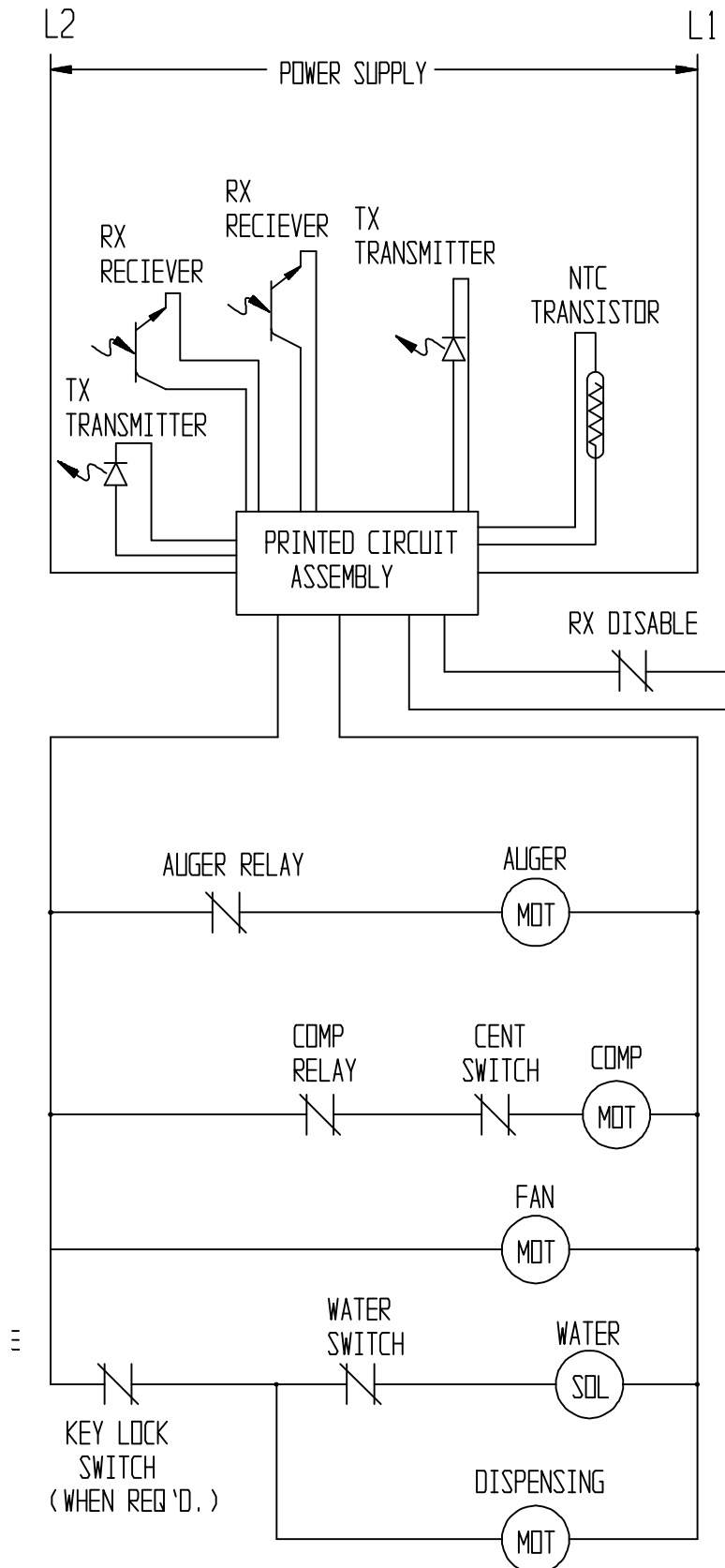

Controls shown in the ice making mode with all dispensing systems in operation.

# TDE470 Service Parts

## Wiring Diagram TDE470AE-6A

