



S E R V E R

SERVE BETTER™

MODEL:

**DPDS**

**DRY PRODUCT DISPENSER STAND,  
DOUBLE**

Series 09L

**86561**

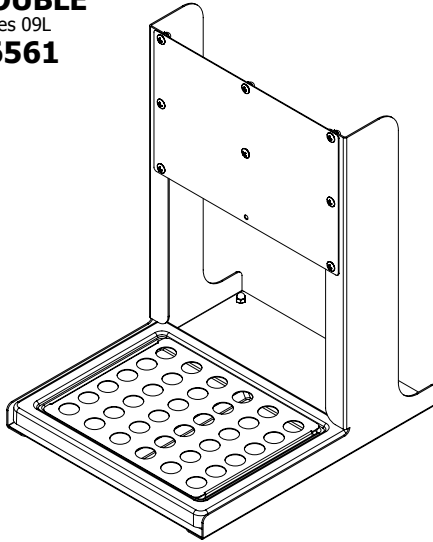

**DPDS**

**DRY PRODUCT DISPENSER STAND,  
SINGLE**

Series 13J

**86666**

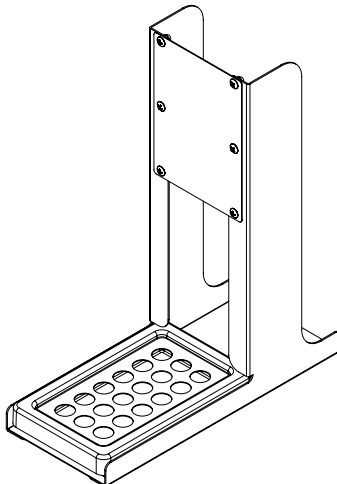

## SAFETY GUIDELINES:

Stainless steel is one of the best materials for food serving and storage, but there are many products which can corrode it. If you notice corrosion beginning on any stainless steel surface, you may need to change the cleansing agent, sanitizing agent, or the cleaning procedures you are using.

- Products containing: acids, alkalines, chlorine, or salt can corrode stainless steel.
- Sauerkraut and Au Jus sauces corrode stainless steel. Server Products, Inc. regrets that we can not honor warranty claims on stainless steel parts that have been affected by sauerkraut or Aus Jus.

## UNIT SET-UP

ALWAYS CLEAN UNIT THOROUGHLY BEFORE EACH USE. SEE SAFETY GUIDELINES AND UNIT CLEANING.

- 1 PLACE BOTTOM PANEL ON TOP OF RIGHT AND LEFT LEG FLANGES. SECURE PANEL WITH FOUR FEET SCREWS AND FOUR HEX CAP NUTS.
- 2 ATTACH MOUNTING BRACKET PANEL ON FRONT OF STAND.
  - Secure six 5/16" screws in four corners and sides of mounting bracket panel.
  - Ⓐ **For Double 86561 Unit:** Secure two 1/4" (shorter) screws in center holes of mounting bracket panel.
  - Secure all screws with hex cap nuts.
  - Place drip tray cover on drip tray.
  - Place drip tray on bottom panel.

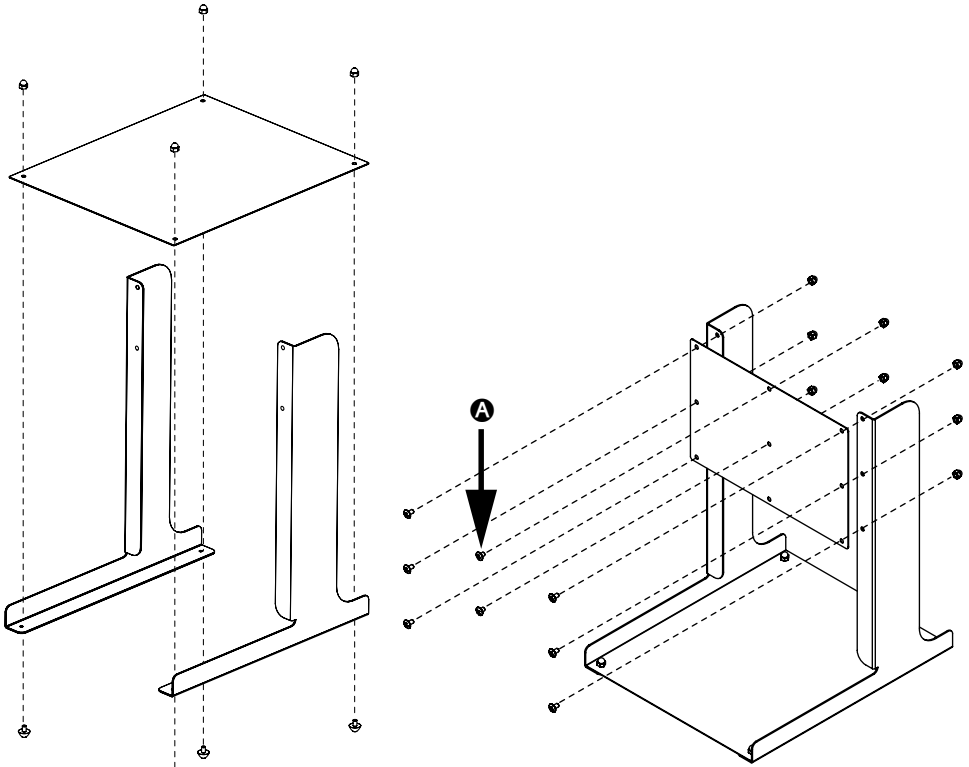

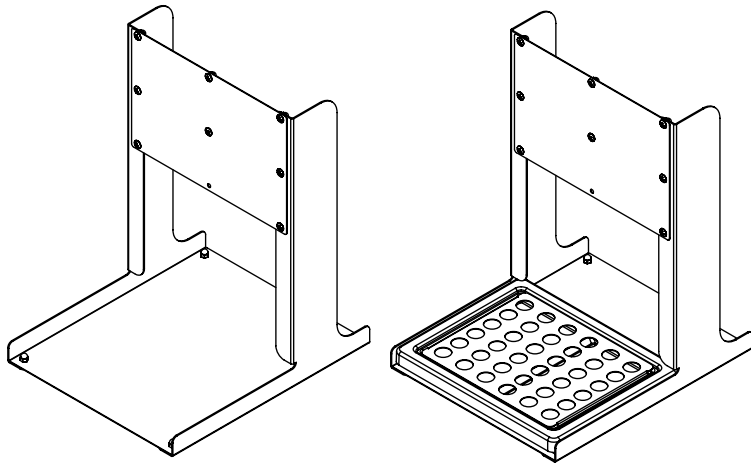
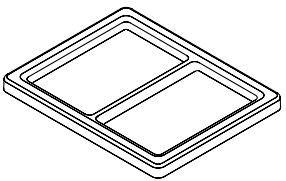
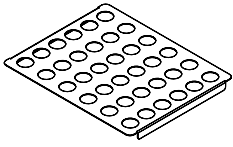
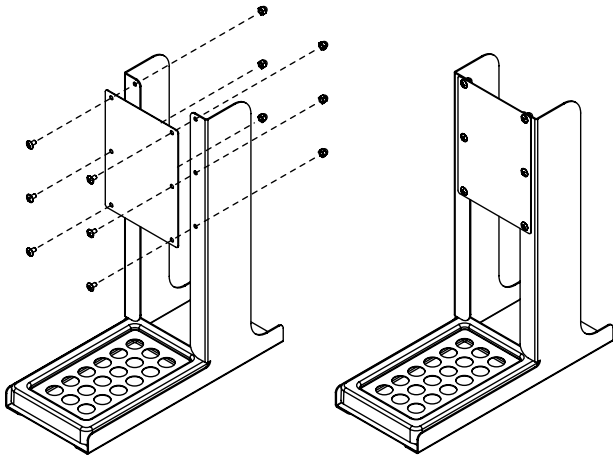

## UNIT CLEANING

BEFORE FIRST USE AND AFTER USE DAILY OR REGULARLY, DISASSEMBLE AND CLEAN PARTS. FOR SAFE AND PROPER CARE, AND TO PREVENT CORROSION, OF PARTS, IT IS IMPORTANT TO CLEAN, RINSE, SANITIZE, AND DRY PARTS DAILY OR REGULARLY. FAILURE TO COMPLY WITH ANY OF THESE INSTRUCTIONS MAY VOID UNIT WARRANTY.

- ❶ WASH ALL REMOVABLE PARTS WITH DISHWASHING DETERGENT AND HOT WATER. RINSE THOROUGHLY AND DRY WITH A CLEAN SOFT CLOTH.
  - A general purpose, nonabrasive cleaner may be used on hard to remove food deposits.
  - You may use a mildly abrasive NYLON or brass brush to remove any stubborn food or mineral deposits on interior surfaces of unit.
  - Do not use abrasive cleansers, scrapers, steel pads, steel wool, or other cleaning tools that can scratch surfaces.
  - Do not use caustic cleansers nor cleansing agents with high concentrations of acid, alkaline or chlorine. These agents can corrode metal parts.
  - Fully rinsing all parts can help prevent corrosion.
  - Various elements and minerals, such as chlorides in tap water, can accumulate on stainless steel parts and create corrosion.
  - To prevent corrosion on any stainless steel parts, it is important to fully dry with a clean soft cloth regularly.
- ❷ WIPE EXTERNAL SURFACES OF UNIT WITH A CLEAN DAMP CLOTH. DRY WITH A CLEAN SOFT CLOTH.
  - A nontoxic glass cleaner may be used for cleaning any stainless steel parts.
- ❸ SANITIZE ALL PARTS FOLLOWING YOUR LOCAL SANITIZATION REQUIREMENTS. ALL PARTS IN CONTACT WITH FOOD MUST BE SANITIZED.
  - Allow parts to fully air dry after sanitization.

## GENERAL SERVICE, REPAIR, OR RETURNS

Before sending any item to Server Products for service, repair, or return, contact Server Products customer service to request a **Return Authorization Number**. Merchandise must be sent to Server Products with this number.

Merchandise being returned for credit must be in new and unused condition and not more than 90 days old and will be subject to a 20% (percent) restocking charge. Electrical parts (thermostats, heating elements, etc.) are not returnable.

Server Products maintains a fully staffed service department with highly skilled factory trained personnel. Service is extremely prompt. Under normal circumstances, a repaired unit is shipped out the day after it is received. Labor charges are reasonable.

## SERVICE

Contact your dealer or Server Products Inc. customer service department for the following:

### ORDERING REPLACEMENT PARTS

#### Be prepared to give this information:

- Model Letters/Name/Numbers
- Part Numbers- P/N
- Series Numbers/Letters
- Part Description

This information and other important data is stamped on the lid or cylinder of pumps or on the bottom or back side of every unit.

## SERVER PRODUCTS LIMITED WARRANTY

All Server Products equipment is backed by a two-year limited warranty against defects in materials and workmanship. For complete warranty information go to: [www.server-products.com](http://www.server-products.com)



**Server Products Inc.**

3601 Pleasant Hill Road  
Richfield, WI 53076 USA



262.628.5600



800.558.8722



262.628.5110



[spsales@server-products.com](mailto:spsales@server-products.com)



[www.server-products.com](http://www.server-products.com)