



S E R V E R

SERVE BETTER™

## Server Express™ Pumps

### MODELS:

07392

07398

07726

07949

Used with pouches up to  
1½ gallons with 16mm fitments.

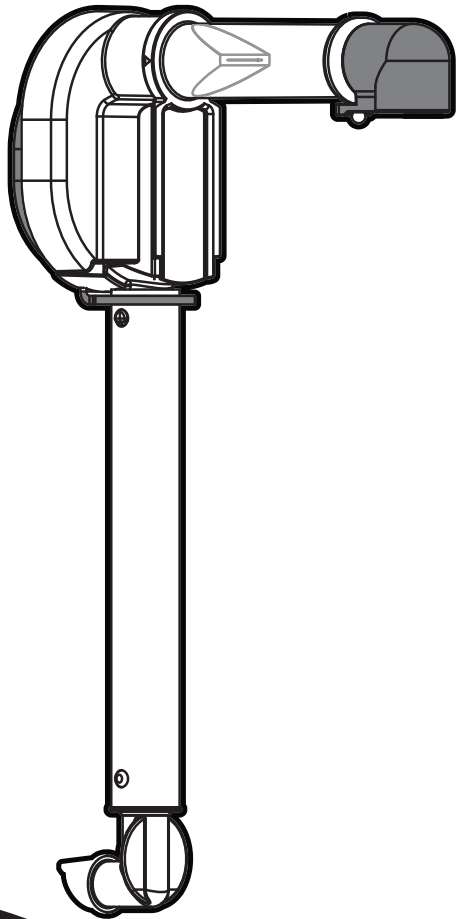
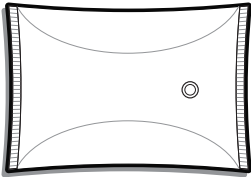

### ***Thank You***

...for purchasing our Server Express™ Pump.  
Express™ pouched condiment systems are sealed  
and sanitary, achieve excellent evacuation and have  
only a few parts for easy clean-up.

SIMPLIFY CONDIMENT MANAGEMENT — GO POUCHED

# ASSEMBLY

WASH ALL PARTS  
PROPERLY BEFORE USE. See page 3.

## 1 INSERT PINCH VALVE

into pump housing.

*TIP: Squeeze the pinch valve open before installation to ensure it isn't stuck shut.*

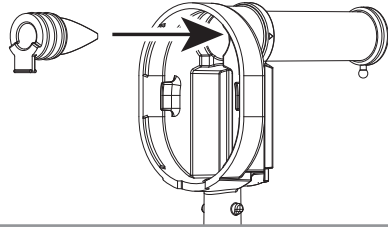

## 2 INSTALL DOME

Press dome into housing fully. Ensure valve flap covers bottom opening.

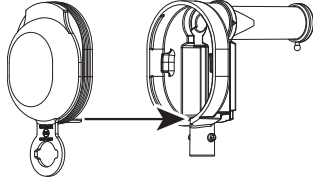

Wrap loop around lower opening to secure dome.

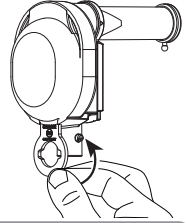

## 3 INSTALL TUBE

Lubricate with a small amount of clean water. Rotate and position until both pegs on housing fit into holes on tube.

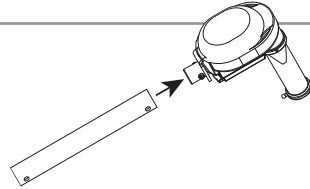

## 4 INSERT CONNECTOR

Lubricate with a small amount of clean water. Rotate and position until both pegs on connector fit into holes on tube. Connector must point away from end of discharge tube.

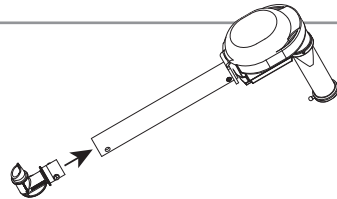

## 5 SELECT DISCHARGE FITTING

if applicable. Page 4 lists discharge fitting size(s) included with each pump model.

### CONSISTENCY OF WHAT YOU DISPENSE

### SUGGESTED FITTING SIZE

THIN (hot sauce) ..... SMALL  
THICK (ketchup or mustard)..... MEDIUM  
PARTICULATES (relish or tartar sauce).... LARGE

*Fittings are marked small, medium or large on bottom.*

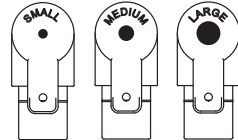

## 6 INSERT DISCHARGE FITTING

into pump housing discharge tube.

Place loop of fitting around peg on end of discharge tube to secure.

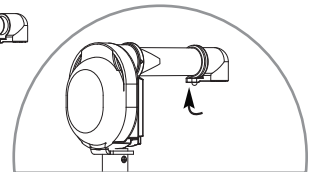
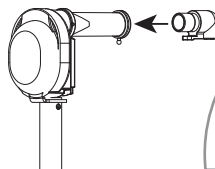

# SAFETY



## IMPORTANT

Clean, rinse, sanitize, and dry parts daily or regularly to comply with local sanitization requirements.

According to food and safety regulations, most foods must be stored and/or served at certain temperatures or they could become hazardous. Check with local food and safety regulators for specific guidelines. Server Products, Inc. cannot be responsible for the serving of potentially hazardous product.



NSF International (National Sanitation Foundation) lists this pump as: "Not acceptable for dispensing potentially hazardous foods."

ADA  
compliant

# DISASSEMBLY

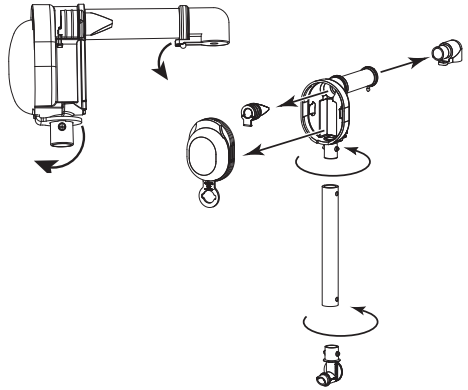

# CLEANING

## 1 FLUSH & RINSE

all pump surfaces with hot water. Place lower end of pump into container of hot water and operate pump until all remaining product is expelled and only hot water is discharged.

## 2 DISASSEMBLE & CLEAN

all washable parts with soap and hot water. Use brush to clean any confined areas.

## 3 RINSE

 fully with clear water.

## 4 SANITIZE

all parts according to local sanitization requirements. All parts in contact with food must be sanitized.

## 5 AIR DRY

 all parts fully.

# YES!

Use dishwashing soap, hot water and nylon brush

- Dishwasher safe
- Do not use abrasive, caustic or ammonia based cleansers.
- Do not use cleansing agents with high concentrations of acid, alkaline or chlorine.
- Do not use metal scrapers or cleaning pads that could scratch surfaces.

# TROUBLESHOOTING

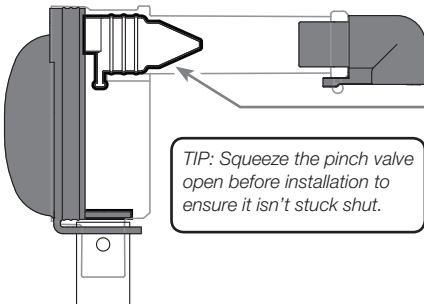

## DIFFICULT TO ATTACH PARTS?

- Wet parts with clean water to help fit.

## PRODUCT DOESN'T PUMP?

- Ensure pinch valve is inserted in housing.
- Ensure connector is snapped fully in place to fitment in pouch.
- Ensure pump is properly installed in unit.
- Clean pump thoroughly.

## DOMES POP OFF?

- Clean thoroughly. Food residue could prevent a tight seal between dome and housing.
- Ensure dome edges are flush with housing.

# PUMP COMPONENT PART NUMBERS

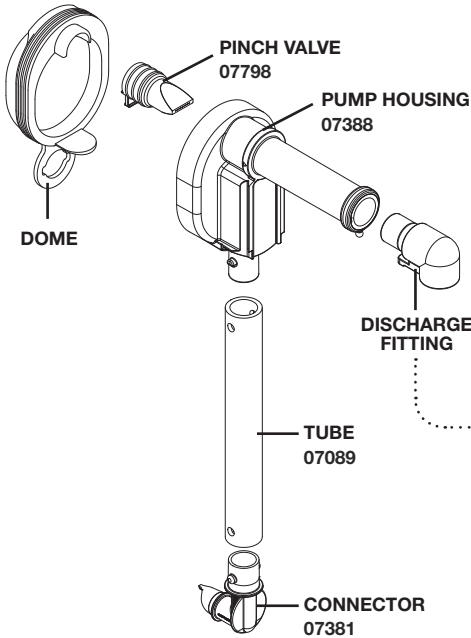

PART	QTY	DESCRIPTION
07798	1	LARGE PINCH VALVE
07388	1	PUMP HOUSING
07089	1	7" TUBE
07381	1	CONNECTOR, 16MM

DOME FOR MODELS 07392, 07398, 07726		
07383	1	PUMP DOME, BLACK
DOME FOR MODEL 07949		
07399	1	PUMP DOME, BLUE

PUMP MODEL	INCLUDED DISCHARGE FITTING(S)
07392	MEDIUM & LARGE FITTINGS
07398	MEDIUM FITTING
07726	SMALL & MEDIUM FITTINGS
07949	LARGE FITTING

DISCHARGE FITTINGS (VARIOUS SIZES)	
07795	DISCHARGE FITTING, .156, SMALL
07796	DISCHARGE FITTING, .256, MEDIUM
07797	DISCHARGE FITTING, .394, LARGE

## SERVER PRODUCTS LIMITED WARRANTY

**2**  
YEAR  
WARRANTY



Server Products equipment is backed by a two-year limited warranty against defects in materials and workmanship. For complete warranty information go to:

[www.Server-Products.com](http://www.Server-Products.com)

## GENERAL SERVICE, REPAIR OR RETURNS

Before sending any item to Server Products for service, repair, or return, contact Server Products customer service to request a **Return Authorization Number**. Merchandise must be sent to Server Products with this number. Service is extremely prompt. Typically, units are repaired and ship out within 48 hours of receipt.

Merchandise being returned for credit must be in new and unused condition and not more than 90 days old and will be subject to a 20% restocking charge.

## HELP or ORDERING REPLACEMENT PARTS

### Server Products Inc.

3601 Pleasant Hill Road  
Richfield, WI 53076 USA



262.628.5600 | 800.558.8722



[SPSALES@SERVER-PRODUCTS.COM](mailto:SPSALES@SERVER-PRODUCTS.COM)

Please be prepared with the **Part Numbers** for your items. Individual part numbers are listed above.