



S E R V E R

SERVE BETTER™

New Carbon's Batter Serving Center

MODEL:

BSC

87319

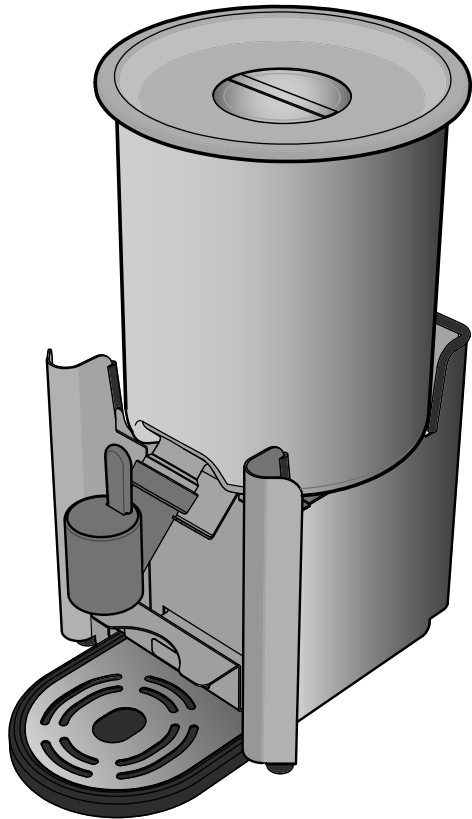

Thank You

...for purchasing this Batter Serving Center.
Easily dispense batter from a convenient vessel.

DISPENSE BETTER—SERVE BETTER

SAFETY



According to food and safety regulations, most foods must be stored and/or served at certain temperatures or they could become hazardous. Check with local food and safety regulators for specific guidelines.

Be aware of the product you are serving and the temperature the product is required to maintain. Server Products, Inc. cannot be responsible for the serving of potentially hazardous product.

IMPORTANT

Clean, rinse, sanitize, and dry parts daily or regularly to comply with local sanitization requirements.



NSF International listed.

CLEANING

1 CLEAN

After disassembling, thoroughly clean all washable parts with soap and hot water.

2 RINSE

 fully with clear water.

3 SANITIZE

all parts according to local sanitization requirements. All parts in contact with food must be sanitized.

4 AIR DRY

 all parts fully.

5 CLEAN EXTERNAL SURFACES

- Wipe daily with a clean damp cloth.
- Dry with a clean soft cloth.
- Glass and surface cleaners approved for use in food contact areas may be used.

YES!

Use dishwashing soap and hot water



CARE OF STAINLESS STEEL

- If you notice corrosion beginning on any stainless steel surface, you may need to change the cleansing agent, sanitizing agent, or the cleaning procedures you are using.
- A mildly abrasive nylon or brass brush may be used to remove any stubborn deposits.
- Fully rinsing and drying all parts can help prevent corrosion. Elements and minerals in tap water can accumulate on stainless steel parts and create corrosion.
- Do not use abrasive, caustic or ammonia based cleansers.
- Do not use products containing acids, alkalines, chlorine, or salt. These agents can corrode stainless steel.
- Do not use metal scrapers or cleaning pads that could scratch surfaces.

AFTER CLEANING VALVE:

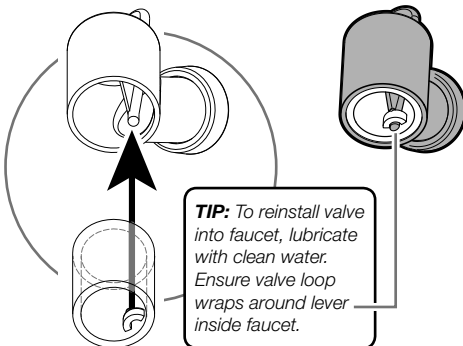

SETUP



WASH ALL PARTS PROPERLY BEFORE USE. See page 2.

1 ATTACH FAUCET TO VESSEL

- Insert faucet neck into vessel spout.
- Screw faucet connector to vessel.

2 PLACE VESSEL ONTO BASE

3 POSITION DRIP TRAY UNDER BASE

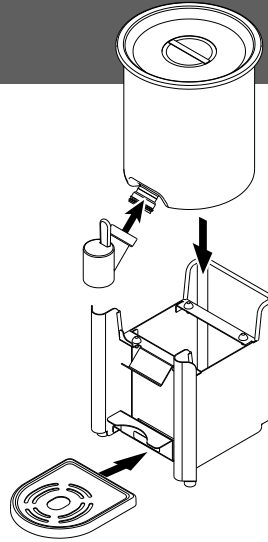

TAKE-DOWN

1 REMOVE DRIP TRAY

2 REMOVE VESSEL & ANY REMAINING FOOD PRODUCT

3 DISASSEMBLE FAUCET

- Unscrew and remove faucet from food vessel.
- Remove valve from faucet:
Pinch valve and gently pull it out for cleaning.

TROUBLESHOOTING

UNIT DISPENSES LITTLE OR NO PRODUCT? FAUCET DRIPS?

- Ensure faucet connector is threaded correctly to create tight seal.
- Ensure there is enough product remaining to dispense.
- Ensure lever inside faucet is placed correctly within valve loop.
- Check valve for defects.
Replace if necessary.

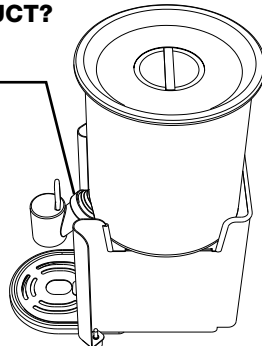

PARTS

87319 BATTER SERVING CENTER

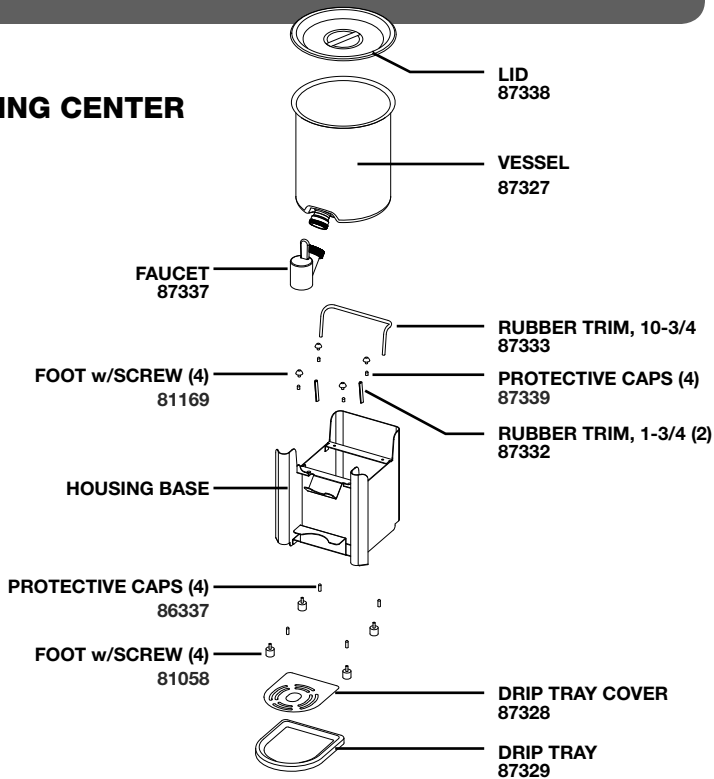

SERVER PRODUCTS LIMITED WARRANTY

2
YEAR
WARRANTY



Server Products equipment is backed by a two-year limited warranty against defects in materials and workmanship.

For complete warranty information go to:

www.Server-Products.com

GENERAL SERVICE, REPAIR OR RETURNS

Before sending any item to Server Products for service, repair, or return, contact Server Products customer service to request a **Return Authorization Number**. Merchandise must be sent to Server Products with this number. Service is extremely prompt. Typically, units are repaired and ship out within 48 hours of receipt.

Merchandise being returned for credit must be in new and unused condition and not more than 90 days old and will be subject to a 20% restocking charge.

NEED HELP WITH REPLACEMENT PARTS?

New Carbon Co., Inc.

4101 William Richardson Dr.
South Bend, IN 46628

 **574.247.2270**

Please be prepared with your **Series Number** and **Description** located on the back of unit base.
Individual **Part Numbers** listed above.