



01955-REVA\_080414\_ENGLISH

S E R V E R

SERVE BETTER™

MODEL:

**FSF**      **FAST FILL,  
SQUEEZE BOTTLE  
FILLING STATION,  
CRYOVAC™ FITMENT 16MM  
1.5 GALLON**  
Series 13E  
**87690**

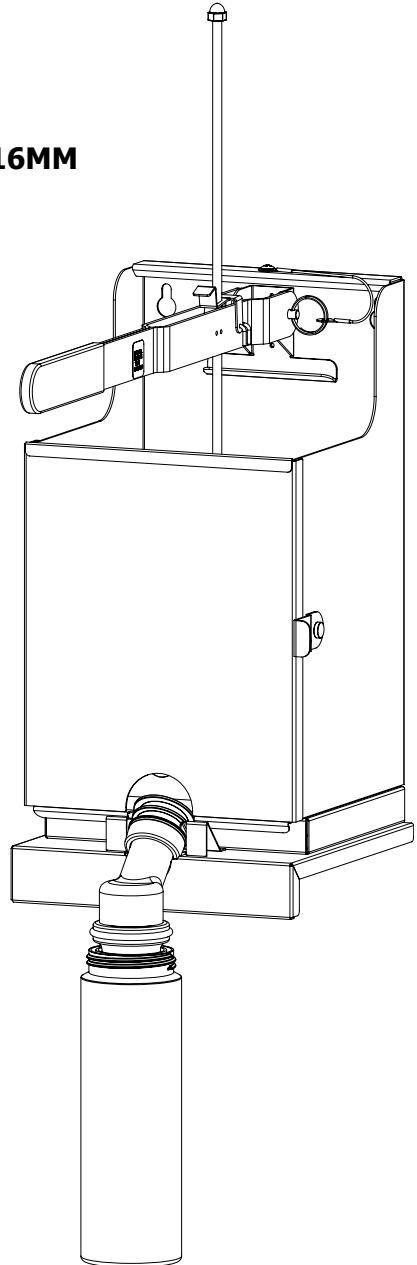

## SAFETY GUIDELINES WHEN USING THIS UNIT:

According to food and safety regulations, most foods must be stored and/or served at certain temperatures or they could become hazardous. Check with local food and safety regulators for specific guidelines.

**Be aware of the product you are serving and the temperature the product is required to maintain. Server Products, Inc. can not be responsible for the serving of potentially hazardous product.**

Stainless steel is one of the best materials for food serving and storage, but there are many products which can corrode it. If you notice corrosion beginning on any stainless steel surface, you may need to change the cleansing agent, sanitizing agent, or the cleaning procedures you are using.

- Products containing: acids, alkalines, chlorine, or salt can corrode stainless steel.

## INSTALLATION OPTIONS

This unit can be set onto a countertop or mounted onto a wall. There are four mounting holes available on back side of unit.

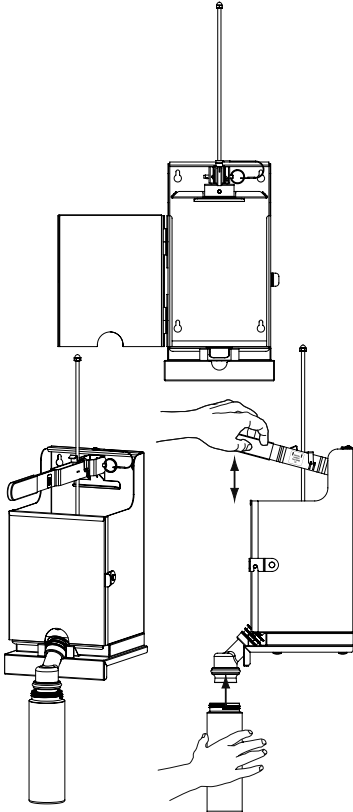

## UNIT SET-UP

ALWAYS CLEAN UNIT THOROUGHLY BEFORE EACH USE AND AFTER USE DAILY.

- 1 POSITION PLUNGER UP ONTO PLUNGER REST TO INSTALL PRODUCT POUCH.**
  - Open unit door by lifting latch.
  - Lift up handle and plunger assembly by depressing handle lever release and lifting handle into horizontal position to allow plunger rod to move up freely.
  - Tip plunger front up enough to position plunger back up onto plunger rest on back wall of unit.
- 2 INSTALL VALVE BODY AND CONNECTOR ASSEMBLY ONTO PRODUCT POUCH.**
  - Ensure valve nut is installed onto valve body with threading facing out.
  - Install connector into valve body and secure with valve nut threading.
  - Place product pouch on a counter top with circular pouch fitment facing upward.
  - Position valve body and connector assembly directly over center of circular pouch fitment.
  - Press valve body and connector assembly down to pierce through film in circular pouch fitment. Valve body and connector assembly will "snap" securely onto fitment.
  - Valve body and connector assembly is fully engaged into pouch fitment when surface of circular pouch fitment is flush with connector.
  - Prime valve body by applying light pressure on end of product pouch while holding valve body like a cup, so that product does not spill out. Continue to press on product pouch until valve body is full of product.
  - Install silicone valve onto valve body. Push silicone valve down around edges of valve body until silicone valve "snaps" securely into groove on edge of valve body.
- 3 INSTALL POUCH, WITH ATTACHED VALVE BODY, INTO UNIT.**
  - Align connector grooves onto unit valve body holder.
  - Connector groove which is closest to threaded cap on valve body is the groove which must align and slide into holder.
- 4 RELEASE PLUNGER FROM PLUNGER REST ON BACK WALL OF UNIT.**
  - Close unit door and secure latch.
  - Tip plunger front up enough to release plunger back up off of plunger rest on back wall of unit.
  - Set plunger into position resting on product pouch.

## UNIT OPERATION

PLACE BOTTLE TO FILL DIRECTLY UNDER VALVE BODY. PUSH PLUNGER LEVER DOWN TO DISPENSE PRODUCT FROM POUCH INTO BOTTLE.

# UNIT SET-UP

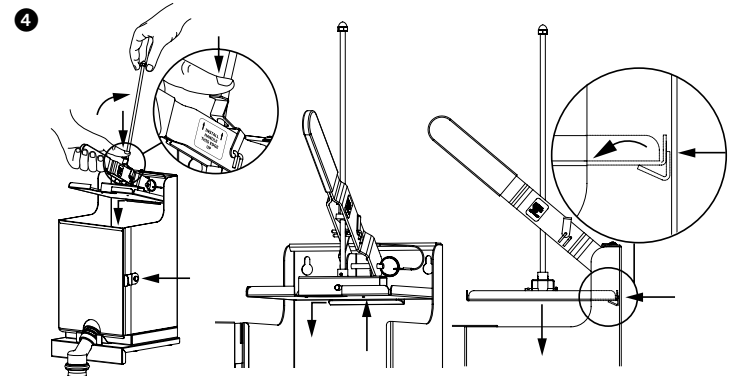
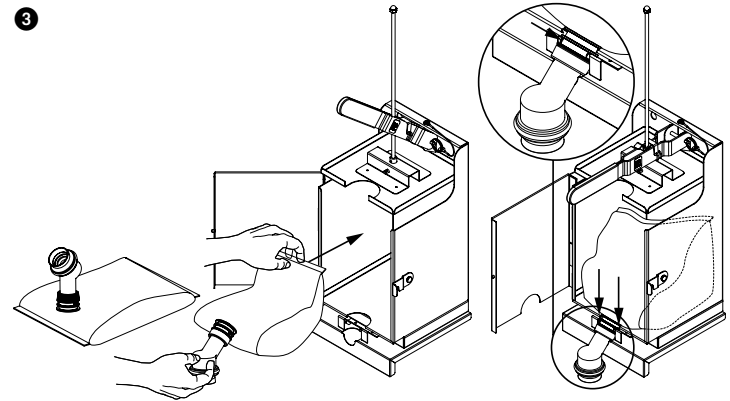
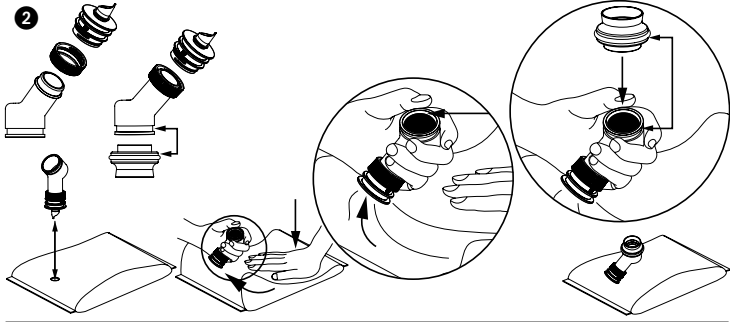
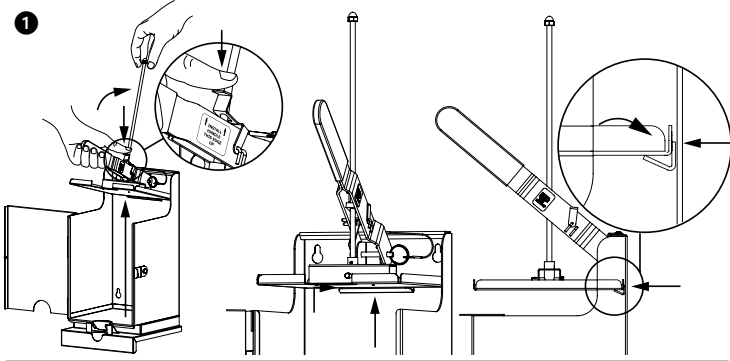

## UNIT TAKE-DOWN

- 1 OPEN UNIT DOOR AND REMOVE PRODUCT POUCH WITH VALVE BODY ATTACHED.
- 2 REMOVE VALVE BODY AND CONNECTOR ASSEMBLY FROM PRODUCT POUCH.
  - Do not discard valve body, connector, or valve nut.

## UNIT CLEANING

BEFORE FIRST USE AND AFTER USE DAILY OR REGULARLY, DISASSEMBLE AND CLEAN PARTS. FOR SAFE AND PROPER CARE, AND TO PREVENT CORROSION, OF PARTS, IT IS IMPORTANT TO CLEAN, RINSE, SANITIZE, AND DRY PARTS DAILY OR REGULARLY. FAILURE TO COMPLY WITH ANY OF THESE INSTRUCTIONS MAY VOID UNIT WARRANTY.

- 1 SEE UNIT TAKE DOWN.
- 2 WASH CLEAN ALL WASHABLE PARTS WITH DISHWASHING DETERGENT AND HOT WATER.
  - Clean all confined areas with any supplied brush(es).
  - **IMPORTANT AREA TO CLEAN: Clean inside valve body thoroughly.**
  - Do not use scrapers, steel pads, steel wool, or other cleaning tools that can scratch surfaces.
  - Mildly abrasive NYLON or brass brush may be used to remove any stubborn food or mineral deposits on interior surfaces of unit.
  - Do not use abrasive cleansers.
  - Do not use caustic cleansers.
  - Do not use cleansing agents with high concentrations of acid, alkaline or chlorine.
  - Do not use ammonia based cleansers.
- 3 FULLY RINSE ALL WASHED PARTS THOROUGHLY WITH CLEAR WATER.
  - To prevent corrosion on parts, it is important to thoroughly and fully rinse washed parts.
- 4 WIPE CLEAN EXTERNAL SURFACES OF UNIT WITH A CLEAN DAMP CLOTH.
  - Nontoxic glass cleaner may be used to clean stainless steel parts.
- 5 DRY ALL PARTS WITH A CLEAN SOFT CLOTH.
  - Various elements and minerals, such as chlorides in tap water, can accumulate on stainless steel parts and create corrosion.
  - To prevent corrosion on stainless steel parts, it is important to thoroughly and fully dry with a clean soft cloth regularly.
- 6 SANITIZE ALL PARTS FOLLOWING LOCAL SANITIZATION REQUIREMENTS. ALL PARTS IN CONTACT WITH FOOD MUST BE SANITIZED.
  - Allow parts to fully air dry after sanitization.

## GENERAL SERVICE, REPAIR, OR RETURNS

Before sending any item to Server Products for service, repair, or return, contact Server Products customer service to request a **Return Authorization Number**. Merchandise must be sent to Server Products with this number.

Merchandise being returned for credit must be in new and unused condition and not more than 90 days old and will be subject to a 20% (percent) restocking charge. Electrical parts (thermostats, heating elements, etc.) are not returnable.

Server Products maintains a fully staffed service department with highly skilled factory trained personnel. Service is extremely prompt. Under normal circumstances, a repaired unit is shipped out the day after it is received. Labor charges are reasonable.

## SERVICE

Contact your dealer or Server Products Inc. customer service department for the following:

### ORDERING REPLACEMENT PARTS

#### Be prepared to give this information:

- Model Letters/Name/Numbers
- Part Numbers- P/N
- Series Numbers/Letters
- Part Description

This information and other important data is stamped on the lid or cylinder of pumps or on the bottom or back side of every unit.

## SERVER PRODUCTS LIMITED WARRANTY

All Server Products equipment is backed by a two-year limited warranty against defects in materials and workmanship. For complete warranty information go to: [www.server-products.com](http://www.server-products.com)



### Server Products Inc.

3601 Pleasant Hill Road  
Richfield, WI 53076 USA



262.628.5600



800.558.8722



262.628.5110



[spsales@server-products.com](mailto:spsales@server-products.com)



[www.server-products.com](http://www.server-products.com)