



S E R V E R

SERVE BETTER™

## ConserveWell™

**DROP-IN UNIT**

MODEL: CW-DI

**87772**

120V USA

with Countdown Timer



### ***Thank You***

...for purchasing our ConserveWell™ Drop-In Heated Utensil Holder. This unit holds serving utensils above 140°F, keeping them safe while saving water, energy and money. Countdown timer ensures scheduled change-outs.

SAVE WATER. SAVE MONEY.

# SETUP

**YOU WILL NEED:**  
Phillips-head Screwdriver



**YOU MAY NEED:**  
Appropriate personnel and tools to cut countertop hole(s)



## **PRACTICE SAFETY. WASH PAN & PAN LINER PROPERLY BEFORE USE.**

See pages 8 & 9.

### **1 SELECT COUNTERTOP HOLE**

for unit to drop into.

Consider best placement for ease of use.

6" of clearance needed below countertop.

Ensure cord can reach power source.

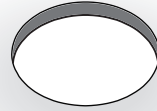

#### **EXISTING HOLE**

Unit fits within countertop hole cutout diameters 5.5" –6.5"

**TIP:** Unit is factory assembled to fit 6" diameter hole. Skip steps 2 & 3 if countertop hole is 6" wide.

#### **NEW HOLE**

Use appropriate personnel and tools to cut a 6" diameter hole.

See below and refer to cutout template for details on an additional optional anti-rotational hole.

## **OPTIONAL**

### **ADD ANTI-ROTATIONAL FOOT**

to prevent unit pivoting within countertop hole.

#### **A REMOVE OUTER SCREW**

from cord cover.

#### **B INSERT ANTI-ROTATIONAL FOOT**

in place of removed screw.

#### **C DRILL FOOT HOLE IN COUNTERTOP**

Refer to cutout template for details.

Drill 3/4" diameter hole in countertop.

#### **5.75" –6.5" diameter countertop holes:**

Locate foot hole center 3.75" from large countertop hole center.

#### **5.5" up to 5.75" diameter countertop hole:**

Locate foot hole center 3.5" from large countertop hole center.

**UNIT & ANTI-ROTATIONAL FOOT WILL FIT INTO CORRESPONDING COUNTERTOP HOLES.**

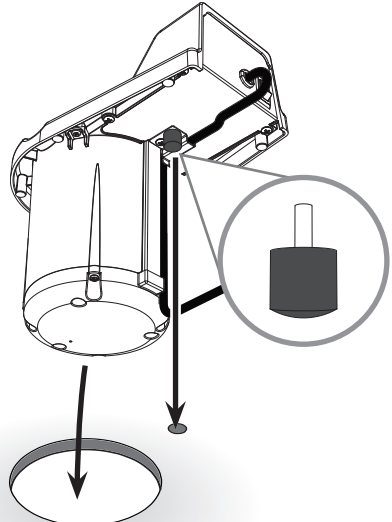
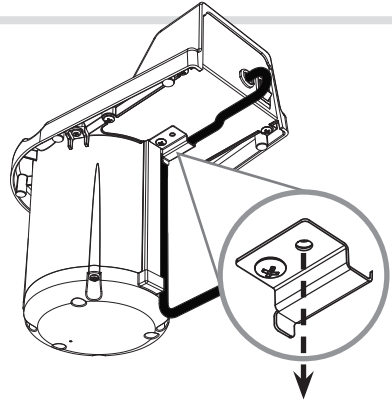

## 2 SELECT LOCATION BLOCK HARDWARE

to create proper fit within countertop hole.

Hole diameter determines which 3 location blocks to use.

If size is between two listed dimensions, refer to smaller diameter.

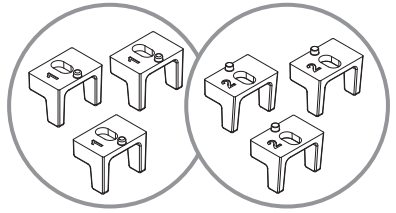

### COUNTERTOP HOLE DIAMETER LOCATION BLOCKS

5.5"	.....	No location blocks needed
5.75"	.....	BLUE, embossed with "1"
6"	.....	BLUE, embossed with "1"
6.25"	.....	RED, embossed with "2"
6.5"	.....	RED, embossed with "2"

## 3 ATTACH 3 LOCATION BLOCKS

to underside of rim.

Place each location block peg into slot in underside of rim.

Slide location blocks either away from or towards base.

Refer to chart below.

### COUNTERTOP HOLE DIAMETER LOCATION BLOCK FITTING

5.5"	.....	Remove all location blocks
5.75"	.....	BLUE, slide towards base
6"	.....	BLUE, slide away from base
6.25"	.....	RED, slide towards base
6.5"	.....	RED, slide away from base

Screw in each location block using 1 screw and Phillips-head screwdriver.

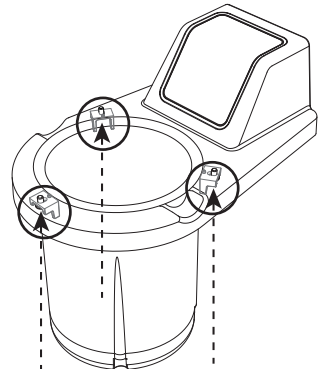
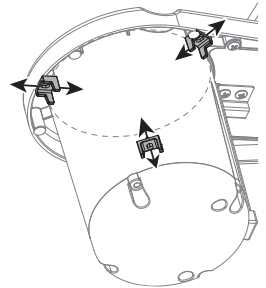
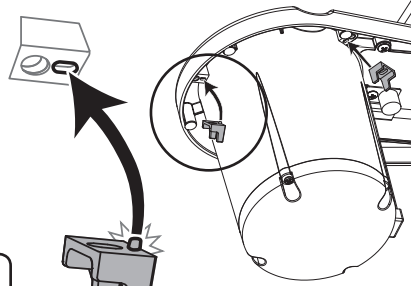

**4****INSERT UNIT**

and cord into countertop hole.

If outlet is above the countertop,  
refer to **CORD COVER** instructions below.

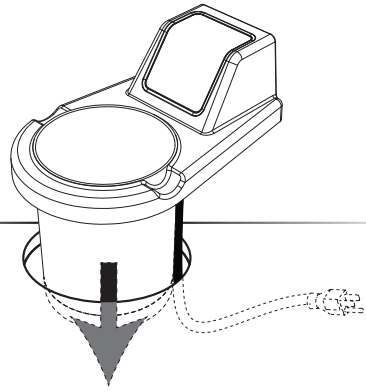
**CORD COVER****CAUTION-****PREVENT CORD DAMAGE**

Secure cord within cord cover  
when plug is used below counter.

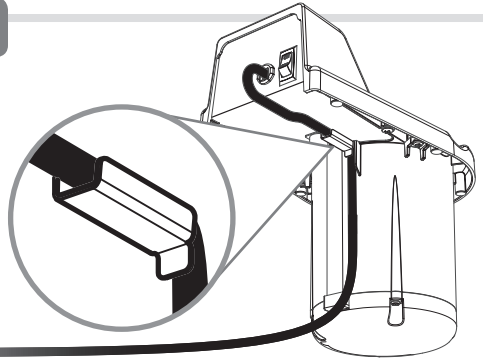
**USE CORD COVER WHEN CORD IS PLUGGED IN BELOW COUNTERTOP**

Affix cord cover using 2 screws  
and Phillips-head screwdriver.

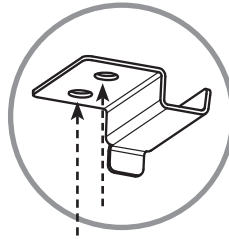
**DO NOT USE CORD COVER WHEN CORD IS PLUGGED IN ABOVE COUNTERTOP****A****DETACH CORD COVER**

Use Phillips-head screwdriver to remove  
both screws.

**B****RELEASE CORD****C****REATTACH CORD COVER**

with both screws.

Secure onto unit in case of future need.

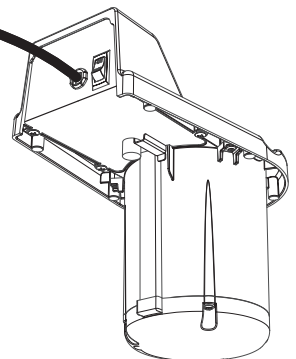

## 5 INSERT WATER PAN

- Insert green pan liner into bottom of pan.
- Fill 28 oz. of HOT water up to fill-line in pan.  
Refer to water temperature charts below.
- Insert pan of water into basin.

Pour water into pan only.

### BE AWARE OF THE WATER TEMPERATURE

Help prevent bacteria growth. The FDA warns that bacteria grow most rapidly in the range of temperatures between 40°F–140°F. (4°C–60°C.)

#### WATER HEATING TIMES (When unit is *not* pre-heated)

INITIAL WATER TEMP.	TARGET TEMPERATURE	
	140°F	145°F
70°F	45 min.	50 min.
110°F	30 min.	40 min.
120°F	20 min.	30 min.
130°F	20 min.	25 min.

**YES** →  
Proper water level in PAN

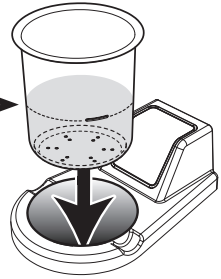

**NO**  
Never pour water directly into BASIN



#### WATER HEATING TIMES (In pre-heated unit)

INITIAL WATER TEMP.	TARGET TEMPERATURE	
	140°F	145°F
70°F	35 min.	40 min.
110°F	20 min.	25 min.
120°F	10 min.	15 min.
130°F	5 min.	10 min.

## 6 PLUG CORD INTO POWER SOURCE

## 7 TURN UNIT ON

Press switch at back of unit.

## 8 PRESS RESET TO START

countdown cycle.

Timer is programmed for 2 hour cycles.

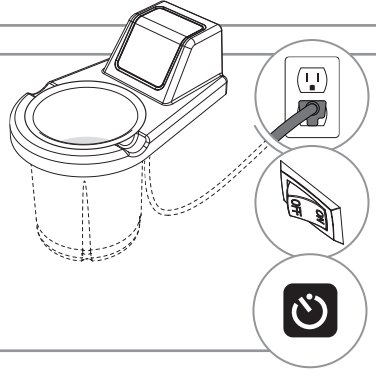

### ONLY USE WITH UTENSILS SAFE IN HIGH TEMPERATURES



**CAUTION-**  
**BURNS MAY RESULT**

**Do not use liquid or gel-filled utensils.**  
Handles become extremely hot.

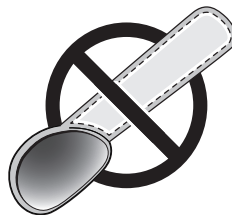

# WHEN COUNTDOWN TIMER ENDS:

Alarm will beep.

Display will indicate "END"



## 1 PRESS RESET TO STOP ALARM



## 2 REMOVE & EMPTY PAN OF WATER



### CAUTION- HOT

Unit, pan and water will be hot.

Take proper care while removing pan.  
Carefully pour water down a drain.  
Keep the pan liner inside pan.

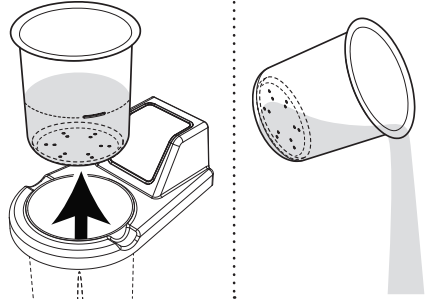

## 3 REFILL & RETURN WATER PAN TO BASIN

Fill 28 oz. of new HOT water up to fill-line in pan.

Insert pan of water into basin.

Never pour water directly into basin of unit.  
Pour water into pan only.

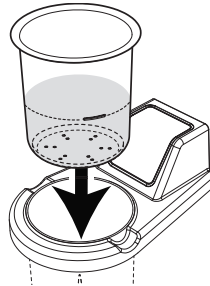

## 4 PRESS RESET BUTTON

to restart the countdown cycle.



# RESETTING COUNTDOWN TIMER

To replace water before countdown cycle completes:

### PRESS RESET BUTTON

to stop the timer.



### CHANGE OUT WATER

(See steps 2 & 3 above.)

### PRESS RESET BUTTON

again to restart timer cycle.



# UNIT TAKE-DOWN



## CAUTION- HOT

Allow unit to cool first  
or take proper care with hot surfaces.

### 1 PRESS SWITCH TO OFF

### 2 UNPLUG CORD

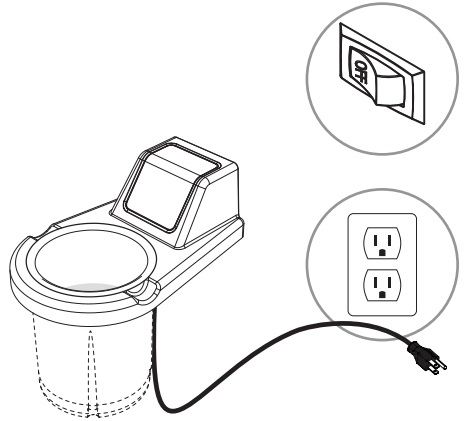

### 3 REMOVE PAN FROM BASIN

Pour water down a drain.  
Clean pan and pan liner (See page 9.)

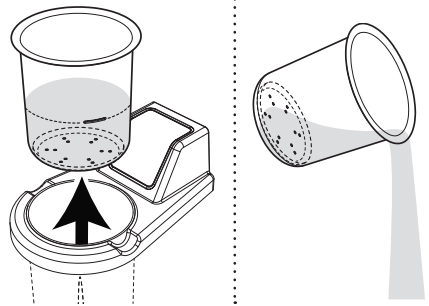

# SAFETY



**WARNING-**  
**ELECTRICAL SHOCK COULD OCCUR**

This unit must be earthed or grounded.

This requires all three prongs (terminals) on cord plug to be plugged into power source.

**IMPORTANT TO KNOW**

*Certain ice cream scoops and spades contain heat-conductive fluid inside handles.*



**CAUTION-**  
**BURNS MAY RESULT**

**Do not use liquid or gel-filled utensils.**  
Handles become extremely hot.

Only use ConserveWell™ with utensils safe at high temperatures.

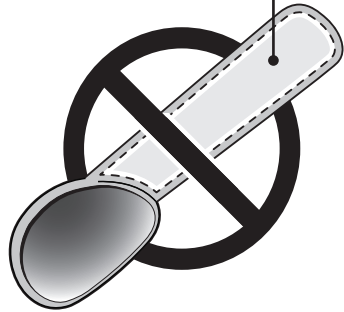

**BE AWARE OF THE WATER TEMPERATURE**

Help prevent bacteria growth. The FDA warns that bacteria grow most rapidly in the range of temperatures between 40°F—140°F. (4°C—60°C.)



NSF International listed.  
This unit is not to be used for serving food.



# CLEANING



## **WARNING-** **ELECTRICAL SHOCK COULD OCCUR**

- Electrical components of unit could be damaged from water exposure or any liquid.
- Never immerse unit into water or any liquid.
- Never use any water jet or pressure sprayer on unit.
- Ensure unit is "OFF" and unplugged.



## **CAUTION- HOT** Allow unit to cool before cleaning.



**YES!**  
Use dishwashing  
soap and hot water

**Pan & Pan Liner are dishwasher safe.**

## CLEAN THE PAN & PAN LINER

- 1 CLEAN**  
Wash water pan and pan liner with soap and hot water.
- 2 RINSE**  
fully with clear water.
- 3 SANITIZE**  
all parts according to local sanitization requirements. All parts in contact with food must be sanitized.
- 4 DRY**  
pan fully with a clean soft cloth.  
Air dry pan liner fully.

## CLEAN EXTERNAL SURFACES

- Wipe daily with a clean damp cloth.
- Dry with a clean soft cloth.
- Glass and surface cleaners approved for use in food contact areas may be used.

# CARE OF STAINLESS STEEL

The water pan is constructed of stainless steel.

If you notice corrosion beginning on any stainless steel surface, you may need to change the cleansing agent, sanitizing agent, or the cleaning procedures you are using.

- A mildly abrasive nylon or brass brush may be used to remove any stubborn deposits on interior surfaces of unit.

- Fully rinsing and drying all parts can help prevent corrosion. Elements and minerals in tap water can accumulate on stainless steel parts and create corrosion.
- Do not use abrasive, caustic or ammonia based cleansers.
- Do not use products containing acids, alkalines, chlorine, or salt. These agents can corrode stainless steel.
- Do not use metal scrapers or cleaning pads that could scratch surfaces.

# WIRING DIAGRAM

**87772**

**120V USA**

**with Countdown Timer**

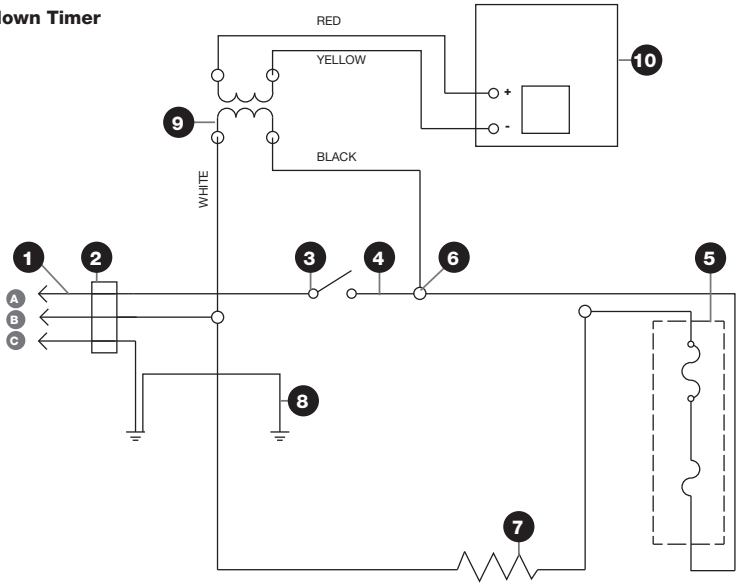

- 1** Cord Assembly  
120V
  - A** Black
  - B** White
  - C** Green
- 2** Bushing/Strain Relief
- 3** Rocker Switch
- 4** Wire Assembly, 18GA, Black, 4"
- 5** Thermal Assembly, Cut-out
- 6** Wire Nut
- 7** 100W Silicone Element
- 8** Wire Assembly, 18GA, Green, 14"
- 9** Transformer Assembly
- 10** Timer Board

# TROUBLESHOOTING

## UNIT DOES NOT HEAT?

- Ensure cord is securely plugged in.
- Ensure power is available from source.
- Ensure unit is on.

## UNIT OVERHEATING?

- Ensure water has not spilled or leaked from pan into the basin.

### CAUTION:

#### WATER IN BASIN MAY STEAM & BURN.

- Allow unit to cool. Pour out any water and dry basin.

## WATER NOT REACHING 140° F?

- Make sure to use HOT water in pan. Refer to temperature charts on page 5.
- Damaged pan may not heat properly. Inspect and replace pan if needed. Use pan liner to protect pan bottom from damage.



## SERVER PRODUCTS LIMITED WARRANTY

**2**  
YEAR  
WARRANTY



Server Products equipment is backed by a two-year limited warranty against defects in materials and workmanship.

For complete warranty information go to:

**[www.Server-Products.com](http://www.Server-Products.com)**

## GENERAL SERVICE, REPAIR OR RETURNS

Before sending any item to Server Products for service, repair, or return, contact Server Products customer service to request a **Return Authorization Number**. Merchandise must be sent to Server Products with this number. Service is extremely prompt. Typically, units are repaired and ship out within 48 hours of receipt.

Merchandise being returned for credit must be in new and unused condition and not more than 90 days old and will be subject to a 20% restocking charge. Electrical parts (thermostats, heating elements, etc.) are not returnable.

**Servicing Cord:** Specific tools are required for safe and proper power supply cord removal and installation. If cord must be replaced, only a representative of the OEM (original equipment manufacturer) or a qualified technician may replace cord. Cord must meet code designation H05 RN-F requirements.

# CONSERVEWELL™ DROP-IN

MODEL: CW-DI

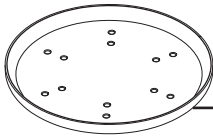

PAN LINER  
87774

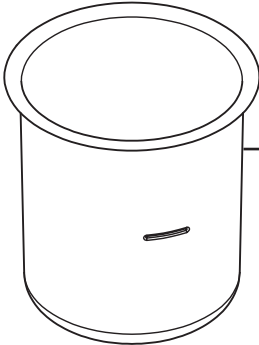

PAN  
87771

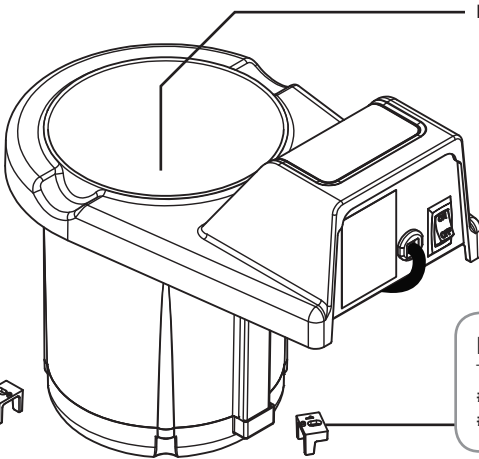

BASIN

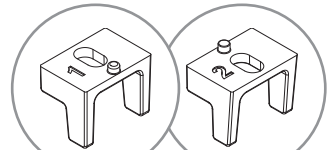

LOCATOR BLOCK HARDWARE

Two Sets Supplied:

#1 BLUE LOCATOR BLOCKS (QTY 3) 87785

#2 RED LOCATOR BLOCKS (QTY 3) 87786



CORD COVER  
87795



ANTI-ROTATIONAL FOOT  
81058



## NEED HELP?

### Server Products Inc.

3601 Pleasant Hill Road  
Richfield, WI 53076 USA



262.628.5600 | 800.558.8722



SPSALES@SERVER-PRODUCTS.COM

Please be prepared with your **Series Number** and **Description** located on the back of the unit.

Individual **Part Numbers** listed above.

# COUNTERTOP CUTOUT TEMPLATE

READ MANUAL FOR COMPLETE INSTRUCTIONS

(FRONT OF UNIT)

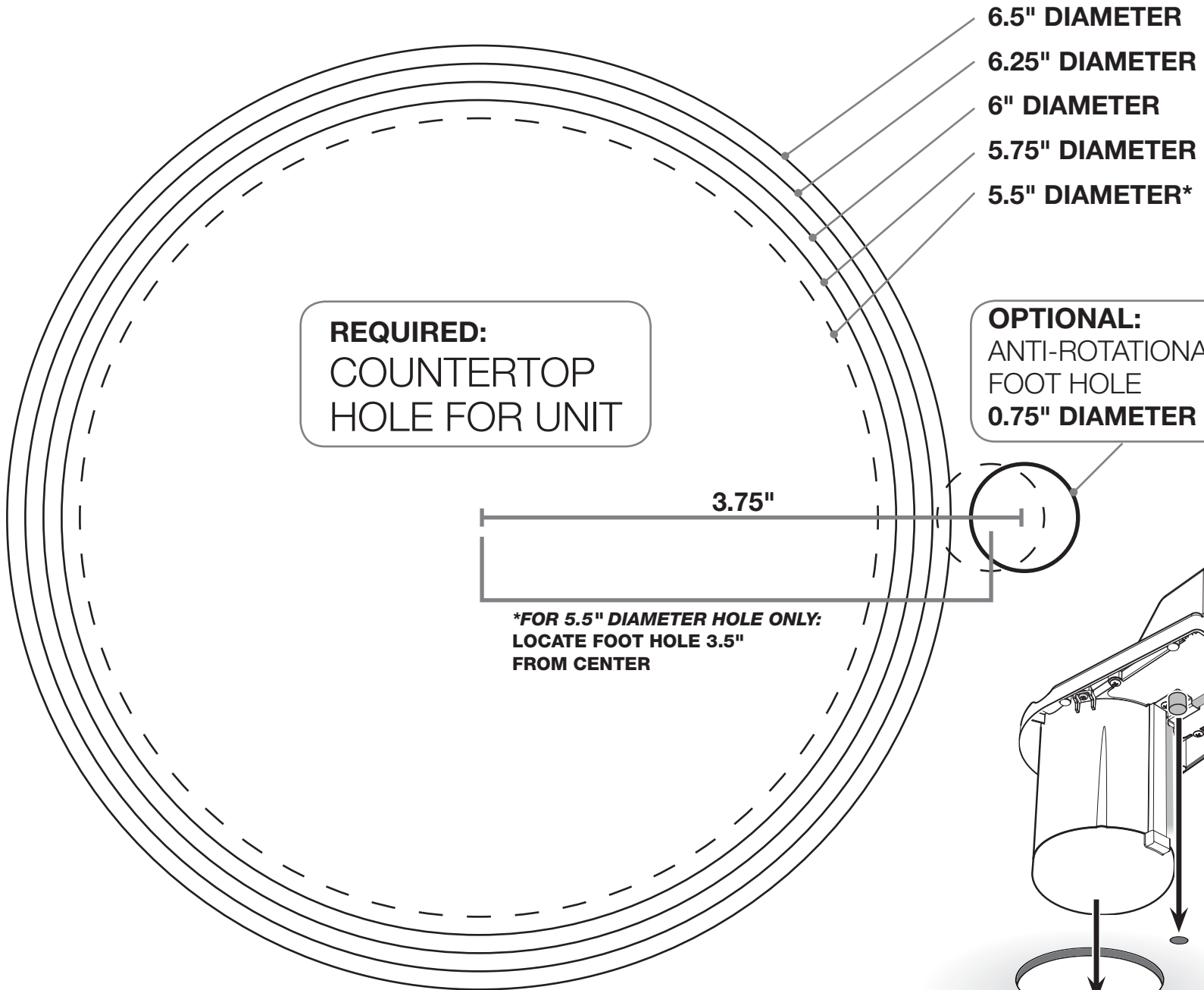

(BACK OF UNIT)

