





Server Products Inc.  
3601 Pleasant Hill Road  
Richfield, WI 53076 USA

-  (262) 628-5600
-  (800) 558-8722
-  (262) 628-5110
-  [spsales@server-products.com](mailto:spsales@server-products.com)
-  [www.server-products.com](http://www.server-products.com)

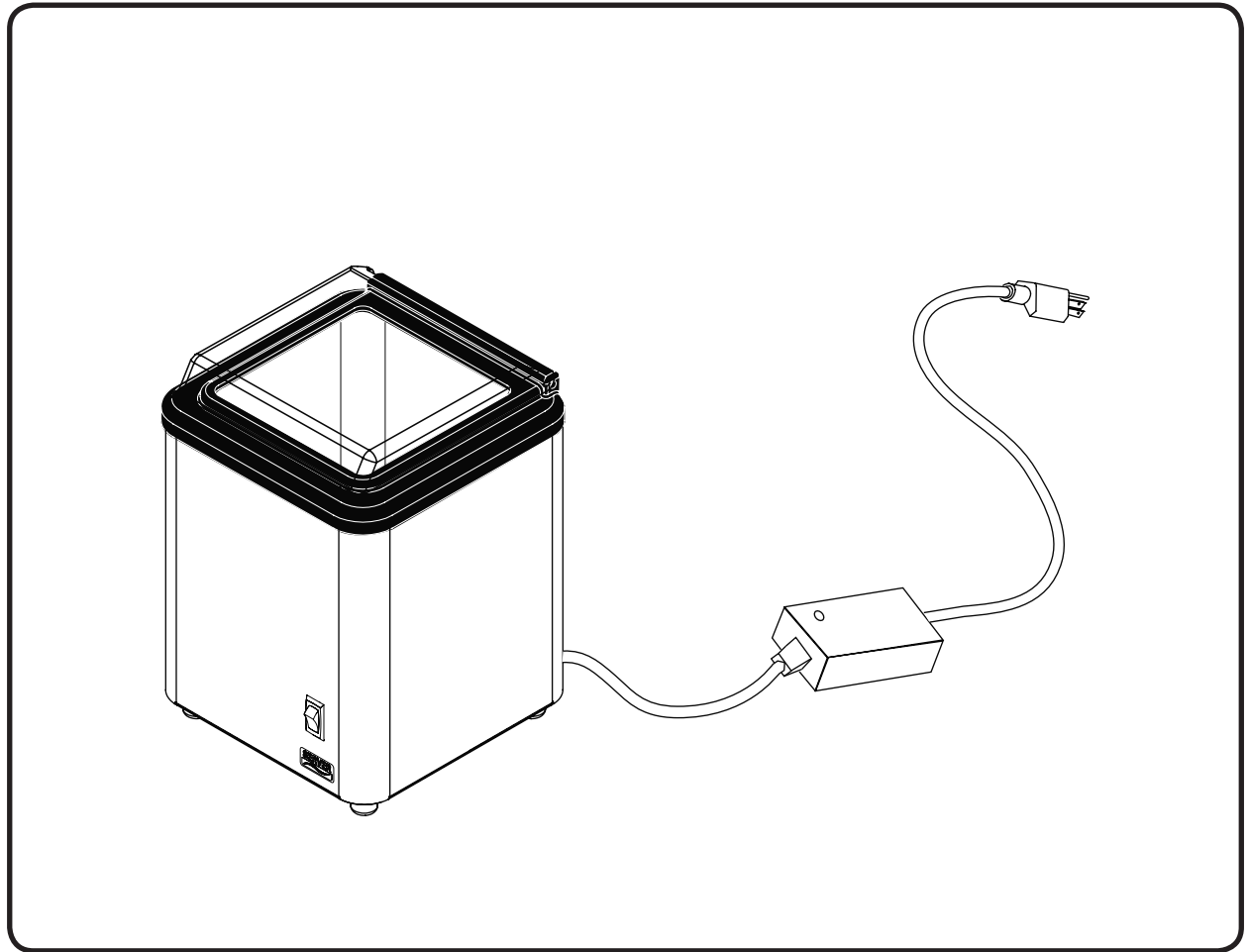

Model: CC	<b>CONDIMENT CHILLER</b>	<b>CONDIMENT CHILLER-Cont Euro</b>	<b>CONDIMENT CHILLER-Aust</b>	<b>CONDIMENT CHILLER-UK</b>
	Series 11A	Series 11A	Series 11A	Series 11A
	Stock No. 86070	Stock No. 86091	Stock No. 86092	Stock No. 86095

## UNIT SET-UP

### ALWAYS CLEAN UNIT THOROUGHLY BEFORE EACH USE.

See Unit Take-Down, Cleaning and Safety Guidelines.

- 1 Power unit up allowing it to pre-cool for 20 minutes.
- 2 Lift lid and fill with product vessel in place. Do not overfill. Maximum capacity is two (2) quarts.
- 3 Close lid to maintain maximum cold temperature. Temperature strip is located on front of product vessel.

**It is recommended to keep unit running 24-7 to prevent pre-cool period and improve performance.**

## UNIT TAKE-DOWN

- 1 Detach power inlet cord from unit.
- 2 Lift up lid, remove any remaining product. Product vessel can be removed for cleaning.

## CLEANING

Before first use and after use daily, remove product vessel to clean, and wipe down unit. Metal parts can corrode. It is important to clean, rinse, sanitize, and dry these parts daily and properly. Failure to comply with any of these instructions may void unit warranty:

- 1 See Unit Take-Down.
- 2 Make sure unit is unplugged from power supply.

**Warning:** Never immerse base or shroud of unit into water. Never use any water jet or pressure sprayer on base or shroud of unit. Electrical shock could occur or electrical components inside the unit base could be damaged from water exposure.

- 3 Wash product vessel and lid with dishwashing detergent and hot water daily. (Lid can be removed by gently pulling hinge tabs out and lifting off.)

Rinse thoroughly and dry with a clean soft cloth.

- You may use a mildly abrasive nylon or brass brush to remove any food or mineral deposits on the interior of the vessel.
  - Do not use any highly alkaline or acidic solvents, steel wool, or other harsh abrasives to clean vessel.
- 4 Wipe external surfaces of base or shroud with a clean damp cloth daily. Dry with a clean soft cloth. You may use a general purpose, nonabrasive cleaner on hard to remove food deposits.

## CLEANING (CONTINUED)

- Do not use abrasive cleansers, scrapers, steel pads, steel wool, or other cleaning tools that can scratch any polished surfaces.
  - A nontoxic glass cleaner may be used for cleaning any stainless steel parts.
- 5 Sanitize parts following your local sanitization requirements. All parts in contact with food must be sanitized.
  - 6 Allow parts to fully air dry after sanitization.
- Various elements and minerals, such as chlorides in tap water, can accumulate on metal parts and create corrosion.
  - To prevent corrosion on metal parts, it is important to fully air dry, as required after sanitization, or to fully dry with a clean soft cloth regularly.

**NOTE:** If unit will not be used or powered up for an extended period after cleaning, remove lid and vessel to allow unit to warm to room temperature and air dry to prevent condensation from developing between vessel and basin.

Unit can remain assembled if powered up and cooling after cleaning and sanitizing.

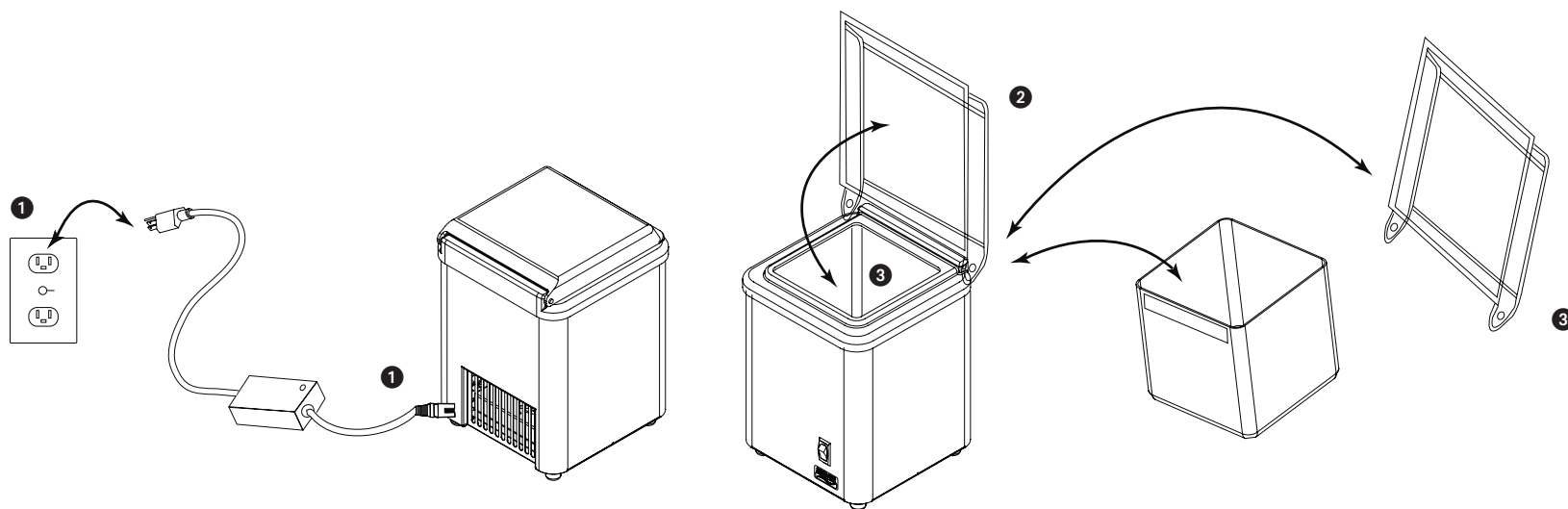

## CLEANING AND/OR CHANGING FILTERS

Changing out and/or cleaning of the filter at minimum once a month—is for optimum cooling and performance.

- 1 Always unplug unit for maintenance and cleaning. See **Unit Take-Down** for specifics.
- 2 After cleaning turn unit over to access filter holder and filter. Lift off filter holder by prying off one edge.
- 3 Remove filter and clean or replace. See filter pack #86067 for replacement filters.
- 4 If necessary wipe down fan cover and surrounding area on underside of unit with cloth dampened with dishwashing liquid or mild sanitizing detergent.

**WARNING:** Make sure to wring any excess water from cloth between wipes. Dripping water **into** unit can cause electrical damage to unit.

- 5 Place new/cleaned filter over fan cover and replace filter holder. Following **Unit Set-Up** instructions, unit should now be ready to return to service.

## SAFETY GUIDELINES

### WHEN USING UNIT:

**WARNING:** This appliance must be earthed. Electrical shock could occur if the unit is not earthed or grounded. This requires all three prongs (terminals) on the cord plug to be plugged into the power source.

According to food and safety regulations, most foods must be stored and/or served at certain temperatures or they could become hazardous. Check with your local food and safety regulators for specific guidelines.

- Be aware of the product you are serving and the temperature the product is required to maintain. Server Products, Inc. can not be responsible for the serving of potentially hazardous product.

Stainless steel is one of the best materials for food serving and storage, but there are many products which can corrode it. If you notice corrosion beginning on any stainless steel surface, you may need to change the cleansing agent, sanitizing agent, or the cleaning procedures you are using.

- Products containing: acids, alkalines, chlorine, or salt can corrode stainless steel.
- Sauerkraut corrodes stainless steel. Server Products, Inc. regrets that we can not honor warranty claims on stainless steel parts that have been affected by sauerkraut.

## SAFETY GUIDELINES (CONTINUED)

- Au Jus sauces can corrode stainless steel. Server Products, Inc. regrets that we can not honor warranty claims on stainless steel parts that have been affected by Au Jus sauces.

### WHEN CLEANING UNIT:

Make sure unit is unplugged.

**WARNING:** Never immerse base or shroud of unit into water. Never use any water jet or pressure sprayer on base or shroud of unit. Electrical shock could occur or electrical components inside the unit base could be damaged from water exposure.

## UNIT TROUBLESHOOTING

Possible Problem:

Unit does not cool.

Solutions:

- Make sure cord is securely plugged in.
- Make sure fan is running.
- Make sure power is available from source.
- Make sure filter is clean and change if necessary.

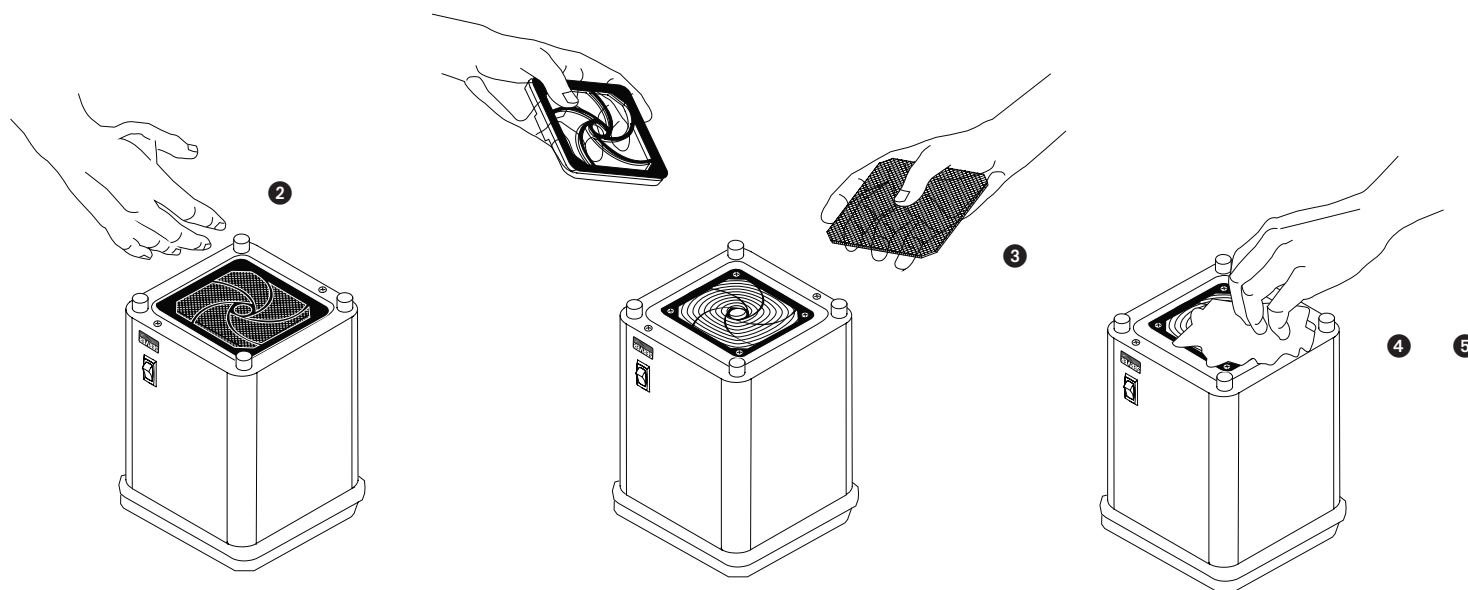

## SERVICE

Contact your dealer or Server Products Inc. Customer Service Department for the following:

### ORDERING REPLACEMENT PARTS

#### BE PREPARED TO GIVE THIS INFORMATION:

- Model Number
- Series Number
- Part Description
- Part Number

You can find the unit model number, series number, and other specific data on a label attached to bottom or back side of every unit.

### Servicing Cord

Specific tools are required for safe and proper power supply cord removal and installation. If cord must be replaced, only a representative of the OEM (Original Equipment Manufacturer) or a qualified technician may replace cord. Cord must meet code designation H05 RN-F requirements.

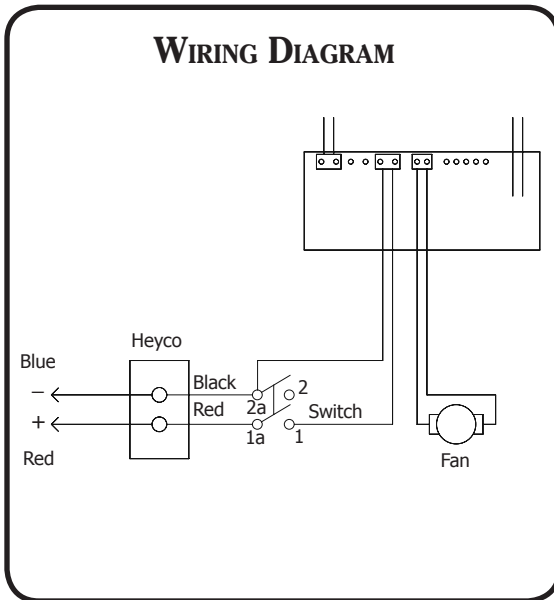

## GENERAL SERVICE, REPAIR, OR RETURNS

Before sending any item to Server Products for service, repair, or return, contact Server Customer Service to request a **RETURN AUTHORIZATION NUMBER**. Merchandise must be sent to Server with this number.

Returned goods must be in new and unused condition and not more than 90 days old and will be subject to a 20% (percent) restocking charge. Electrical parts (thermostats, heating elements etc.) are not returnable.

Server Products maintains a fully staffed service department with highly skilled factory trained personnel.

Service is extremely prompt. Under normal circumstances, a repaired unit is shipped out the day after it is received. Labor charges are reasonable.

## SERVER PRODUCTS LIMITED WARRANTY

All Server Products equipment is backed by a two-year limited warranty against defects in materials and workmanship. For complete warranty information go to: [www.server-products.com](http://www.server-products.com)

### PARTS LIST

Part #	Description
81058	RUBBER FEET (4)
85426	SMALL SERVER LOGO
86029	POWER SUPPLY (NOT SHOWN)
86032	ROCKER SWITCH
86033	BASIN ASSEMBLY
86035	POWER INLET BOARD (NOT SHOWN)
86038	POWER INLET CONNECTOR
86049	BOTTOM ASSEMBLY
86067	REPLACEMENT FILTER PACK (5)
86068	GUARD, FILTER
86078	TOP
86106	LID
86144	VESSEL REPLACEMENT KIT (INCLUDES THERM STRIP)
86472	HOUSING ASSEMBLY
86873	STRIP THERMOMETER
86876	FAN

## 86070

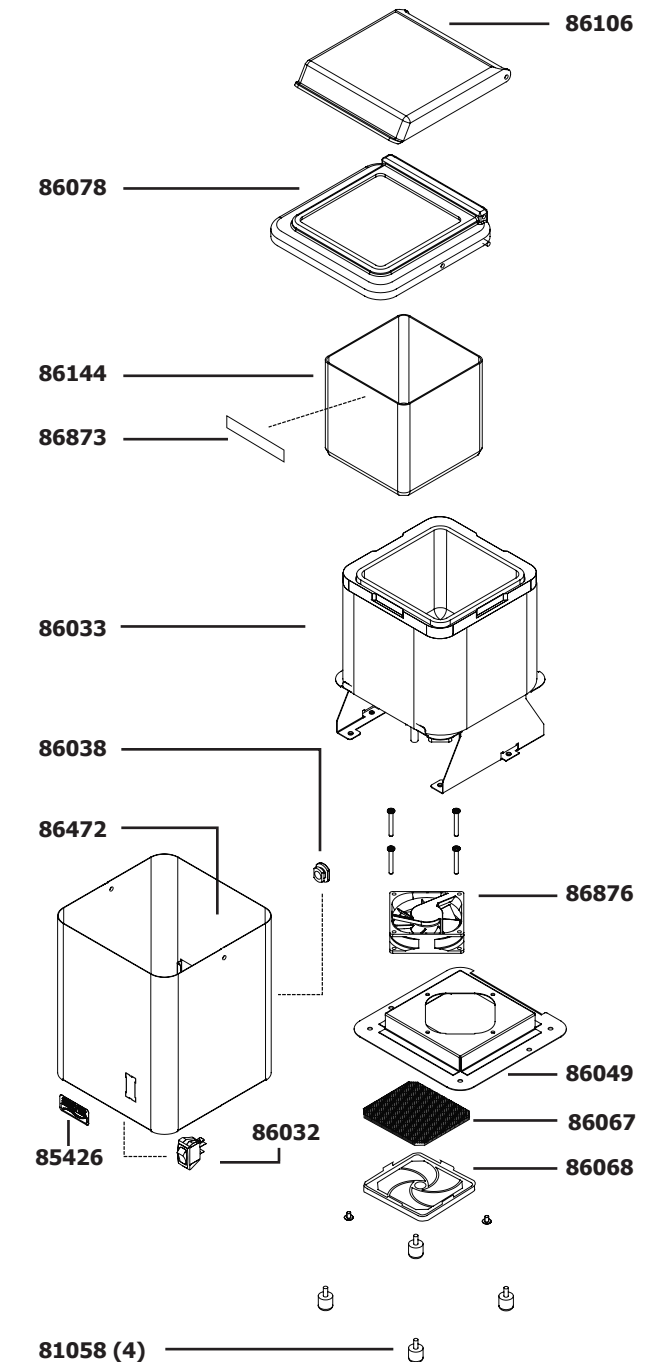

Power Supply	Europe	Australia	U.K.
86029	81351	81352	81355

Chart for 230V Cord Assemblies.