



S E R V E R

SERVE BETTER™

MODEL:

CC 1/3

CONDIMENT CHILLER 1/3

120V

Series 10D

86080

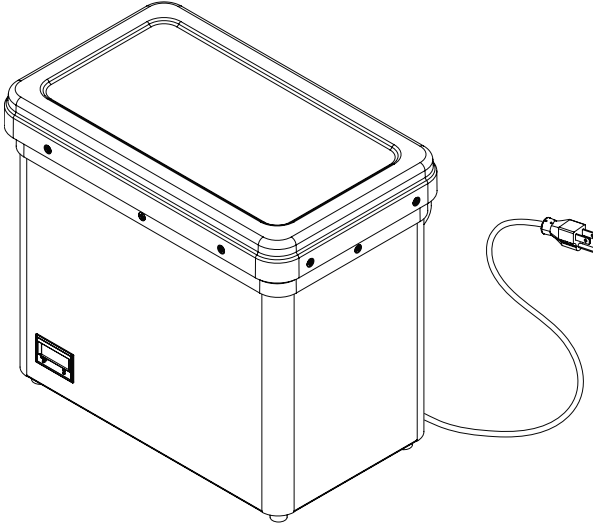

CC 1/3

**CONDIMENT CHILLER 1/3,
NO LID**

120V

Series 10D

86140

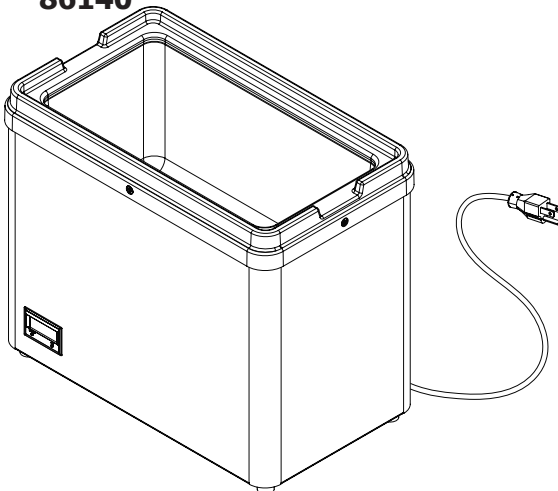

SAFETY GUIDELINES WHEN USING THIS UNIT:

⚠️ ⚡ Warning- Electrical shock could occur:

- **This unit must be earthed or grounded.**
- **This requires all three prongs (terminals) on cord plug to be plugged into power source.**

According to food and safety regulations, most foods must be stored and/or served at certain temperatures or they could become hazardous. Check with local food and safety regulators for specific guidelines.

Be aware of the product you are serving and the temperature the product is required to maintain. Server Products, Inc. can not be responsible for the serving of potentially hazardous product.

Stainless steel is one of the best materials for food serving and storage, but there are many products which can corrode it. If you notice corrosion beginning on any stainless steel surface, you may need to change the cleansing agent, sanitizing agent, or the cleaning procedures you are using.

- Products containing: acids, alkalines, chlorine, or salt can corrode stainless steel.
- Sauerkraut and Au Jus sauces corrode stainless steel. Server Products, Inc. regrets that we can not honor Warranty claims on stainless steel parts that have been affected by sauerkraut or Aus Jus.

Do not place plastic lid, plastic cover, plastic top or plastic chiller block insulation assembly under, in, or near to high heat, as this can melt the plastic.

SAFETY GUIDELINES WHEN CLEANING THIS UNIT:

Ensure unit is "OFF" and unplugged.

⚠️ ⚡ Warning- Electrical shock could occur:

- **Electrical components of unit could be damaged from water exposure or any liquid.**
- **Never immerse unit into water or any liquid.**
- **Never use any water jet or pressure sprayer on unit.**

Plastic Lid:

- Not dishwasher safe.
- Hand Wash Only.

Do not place plastic lid under, in, or near to high heat, as this can melt the plastic.

UNIT SET-UP

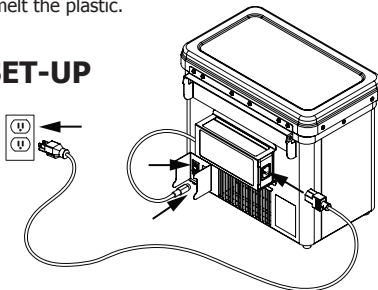

UNIT SET-UP

ALWAYS CLEAN UNIT THOROUGHLY BEFORE EACH USE. SEE UNIT TAKE-DOWN, SAFETY GUIDELINES, AND UNIT CLEANING.

IT IS RECOMMENDED TO ALLOW UNIT TO PRE-COOL WITH JARS OR PANS INSTALLED INTO UNIT BASIN FIRST, THEN POUR FOOD PRODUCT INTO PRE-COOLED JARS OR PANS.

- 1 PLUG CORD INTO POWER SOURCE.
 - Verify that cord is securely plugged into the unit, the power supply (adaptor), and the power source (outlet).
- 2 PRESS SWITCH TO THE "ON" POSITION.
 - Allow unit to pre-cool for 20 minutes.
- 3 INSTALL FOOD PRODUCT INTO UNIT.
 - Food product must always be inside a product jar or pan.
 - Never place food product directly into unit basin without a product jar or pan.
- 4 MAINTAIN MAXIMUM COLD TEMPERATURE.
 - Close lid(s) on unit that includes lid(s).
 - Temperature can be monitored by viewing digital thermometer located on front unit.
 - For best unit cooling and performance, always keep unit on continuously all day and all night, every day and every night, to prevent pre-cool period. Unit should remain on, as a refrigerator.

Server Products Inc. claims no responsibility for actual serving temperature of product. It is the responsibility of the user to ensure that any product is held and served at a safe temperature.

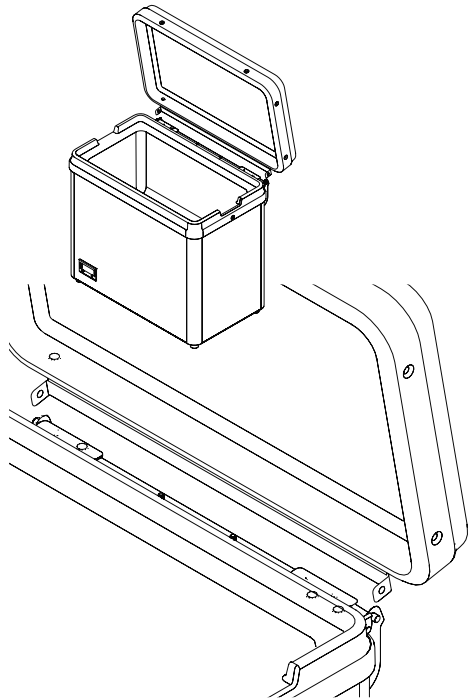

UNIT TAKE-DOWN

- 1 PRESS SWITCH TO "OFF" POSITION.
- 2 UNPLUG CORD.
- 3 REMOVE FOOD PRODUCT VESSEL, JAR, OR POUCH/BOX FROM UNIT BASIN.

REPLACING OR CLEANING FILTER

FOR BEST UNIT COOLING AND PERFORMANCE, CHANGE OR CLEAN FILTER AT A MINIMUM OF ONCE PER MONTH.

- 1 SEE UNIT TAKE DOWN.
- 2 ENSURE UNIT IS "OFF" AND UNPLUGGED.
- 3 TURN UNIT OVER TO ACCESS FILTER HOLDER AND FILTER ON UNDERSIDE OF UNIT.
- 4 LIFT OFF FILTER HOLDER BY PULLING IT OFF FROM ONE EDGE.
- 5 REMOVE FILTER AND CLEAN OR REPLACE.
 - Server Products Inc. Pack of 5 Replacement filters: 86067
 - Filter can be cleaned with hot water and dishwashing detergent. Fully rinse.
- 6 IF NECESSARY, WIPE DOWN FAN COVER AND SURROUNDING AREA ON UNDERSIDE OF UNIT WITH CLOTH DAMPENED WITH DISHWASHING LIQUID OR MILD SANITIZING DETERGENT.

⚠ ⚡ Warning- Electrical shock could occur:

- Be sure to wring out any excess water from cloth before wiping near fan of unit.
- Dripping water into unit can cause electrical damage to unit.

- 7 PLACE NEW OR CLEANED FILTER OVER FAN COVER.
- 8 REPLACE FILTER HOLDER.

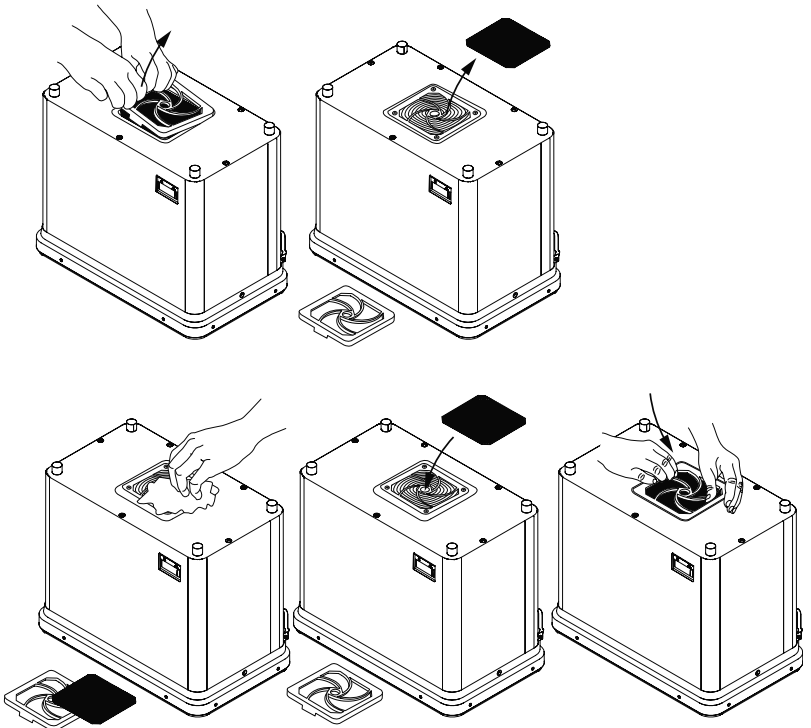

UNIT CLEANING

BEFORE FIRST USE AND AFTER USE DAILY OR REGULARLY, DISASSEMBLE AND CLEAN PARTS. FOR SAFE AND PROPER CARE, AND TO PREVENT CORROSION, OF PARTS, IT IS IMPORTANT TO CLEAN, RINSE, SANITIZE, AND DRY PARTS DAILY OR REGULARLY. FAILURE TO COMPLY WITH ANY OF THESE INSTRUCTIONS MAY VOID UNIT WARRANTY.

- 1 SEE UNIT TAKE DOWN.
- 2 ENSURE UNIT IS "OFF" AND UNPLUGGED.

Warning- Electrical shock could occur:

- **Electrical components of unit could be damaged from water exposure or any liquid.**
 - **Never immerse unit into water or any liquid.**
 - **Never use any water jet or pressure sprayer on unit.**
- 3 WASH CLEAN ALL WASHABLE PARTS WITH DISHWASHING DETERGENT AND HOT WATER.
 - Do not use scrapers, steel pads, steel wool, or other cleaning tools that can scratch surfaces.
 - Mildly abrasive NYLON or brass brush may be used to remove any stubborn food or mineral deposits on interior surfaces of unit.
 - Do not use abrasive cleansers.
 - Do not use caustic cleansers.
 - Do not use cleansing agents with high concentrations of acid, alkaline or chlorine.
 - Do not use ammonia based cleansers.
 - 4 FULLY RINSE ALL WASHED PARTS THOROUGHLY WITH CLEAR WATER.
 - To prevent corrosion on parts, it is important to thoroughly and fully rinse washed parts.
 - 5 WIPE CLEAN EXTERNAL SURFACES OF UNIT WITH A CLEAN DAMP CLOTH.
 - Nontoxic glass cleaner may be used to clean stainless steel parts.
 - 6 DRY ALL PARTS WITH A CLEAN SOFT CLOTH.
 - Various elements and minerals, such as chlorides in tap water, can accumulate on stainless steel parts and create corrosion.
 - To prevent corrosion on stainless steel parts, it is important to thoroughly and fully dry with a clean soft cloth regularly.
 - 7 SANITIZE ALL PARTS FOLLOWING LOCAL SANITIZATION REQUIREMENTS. ALL PARTS IN CONTACT WITH FOOD MUST BE SANITIZED.
 - Allow parts to fully air dry after sanitization.
 - Fully air drying all parts will prevent condensation from developing inside unit basin.

Plastic Lid:

- Not dishwasher safe.
- Hand Wash Only.
- Do not place plastic lid under, in, or near to high heat, as this can melt the plastic.

TROUBLESHOOTING

Possible Problem:

- Unit does not cool.

Possible Solutions:

- Ensure cord is securely plugged in. Verify that cord is securely plugged into the unit, the power supply (adaptor), and the power source (electrical outlet).
- Ensure power is available from source.
- Ensure unit is on.
- Ensure fan is on/running.
- Ensure filter is clean or replace if necessary.

GENERAL SERVICE, REPAIR, OR RETURNS

Before sending any item to Server Products for service, repair, or return, contact Server Products customer service to request a **Return Authorization Number**. Merchandise must be sent to Server Products with this number.

Merchandise being returned for credit must be in new and unused condition and not more than 90 days old and will be subject to a 20% (percent) restocking charge. Electrical parts (thermostats, heating elements, etc.) are not returnable.

Server Products maintains a fully staffed service department with highly skilled factory trained personnel. Service is extremely prompt. Under normal circumstances, a repaired unit is shipped out the day after it is received. Labor charges are reasonable.

SERVICE

Contact your dealer or Server Products Inc. customer service department for the following:

ORDERING REPLACEMENT PARTS

Be prepared to give this information:

- Model Letters/Name/Numbers
- Part Numbers- P/N
- Series Numbers/Letters
- Part Description

This information and other important data is stamped on the lid or cylinder of pumps or on the bottom or back side of every unit.

SERVER PRODUCTS LIMITED WARRANTY

All Server Products equipment is backed by a two-year limited warranty against defects in materials and workmanship. For complete warranty information go to: www.server-products.com



NSF International listed.
(National Sanitation Foundation)



Server Products Inc.

3601 Pleasant Hill Road
Richfield, WI 53076 USA



262.628.5600



800.558.8722



262.628.5110



spsales@server-products.com



www.server-products.com