

## CLEANING

BEFORE FIRST USE AND AFTER USE DAILY OR REGULARLY, DISASSEMBLE AND CLEAN PARTS. FOR SAFE AND PROPER CARE, AND TO PREVENT CORROSION, OF PARTS, IT IS IMPORTANT TO CLEAN, RINSE, SANITIZE, AND DRY PARTS DAILY OR REGULARLY. FAILURE TO COMPLY WITH ANY OF THESE INSTRUCTIONS MAY VOID UNIT WARRANTY.

- 1 SEE DISASSEMBLY.
- 2 WASH CLEAN ALL PARTS WITH DISHWASHING DETERGENT AND HOT WATER.
  - Clean all confined areas with any supplied brush(es).
  - Do not use scrapers, steel pads, steel wool, or other cleaning tools that can scratch surfaces.
  - Mildly abrasive NYLON or brass brush may be used to remove any stubborn food or mineral deposits on interior surfaces of unit.
  - Do not use abrasive cleansers.
  - Do not use caustic cleansers.
  - Do not use cleansing agents with high concentrations of acid, alkaline or chlorine.
  - Do not use ammonia based cleansers.
- 3 FULLY RINSE ALL WASHED PARTS THOROUGHLY WITH CLEAR WATER.
  - To prevent corrosion on parts, it is important to thoroughly and fully rinse washed parts.
- 4 SANITIZE ALL PARTS FOLLOWING LOCAL SANITIZATION REQUIREMENTS. ALL PARTS IN CONTACT WITH FOOD MUST BE SANITIZED.
  - Allow parts to fully air dry after sanitization.
  - Dishwasher safe.

## TROUBLESHOOTING

### Possible Problems:

- Dispenses little or no product.
- Portion control is not consistent.
- Trigger does not push in.

### Possible Solutions:

- Clean unit.
- Ensure unit has adequate level of product to dispense.
- Ensure unit is assembled correctly.
- Ensure closer plate is installed correctly.
- Ensure that unit is not clogged. Some powder products can pack and plug.
- Shake unit.
- Ensure correct trigger is installed per product.

## SAFETY GUIDELINES

According to food and safety regulations, most foods must be stored and/or served at certain temperatures or they could become hazardous. Check with local food and safety regulators for specific guidelines.

**Be aware of the product you are serving and the temperature the product is required to maintain. Server Products, Inc. can not be responsible for the serving of potentially hazardous product.**



## GENERAL SERVICE, REPAIR, OR RETURNS

Before sending any item to Server Products for service, repair, or return, contact Server Products customer service to request a **Return Authorization Number**. Merchandise must be sent to Server Products with this number.

Merchandise being returned for credit must be in new and unused condition and not more than 90 days old and will be subject to a 20% (percent) restocking charge. Electrical parts (thermostats, heating elements etc.) are not returnable.

Server Products maintains a fully staffed service department with highly skilled factory trained personnel. Service is extremely prompt. Under normal circumstances, a repaired unit is shipped out the day after it is received. Labor charges are reasonable.

## SERVICE

Contact your dealer or Server Products Inc. customer service department for the following:

### ORDERING REPLACEMENT PARTS

#### Be prepared to give this information:

- Model Letters/Name/Numbers
- Part Numbers- P/N
- Series Numbers/Letters
- Part Description

This information and other important data is stamped on the lid or cylinder of pumps or on the bottom or back side of every unit.

## SERVER PRODUCTS LIMITED WARRANTY

All Server Products equipment is backed by a two-year limited warranty against defects in materials and workmanship. For complete warranty information go to: [www.server-products.com](http://www.server-products.com)

**Server Products Inc.**  
3601 Pleasant Hill Road  
Richfield, WI 53076 USA

262.628.5600

800.558.8722

262.628.5110

[spsales@server-products.com](mailto:spsales@server-products.com)

[www.server-products.com](http://www.server-products.com)



S E R V E R

SERVE BETTER™

01674-REVD\_080414\_ENGLISH

MODEL:  
**INS**

**INSEASON™,  
DROP**

**INSEASON™,  
SPREAD**

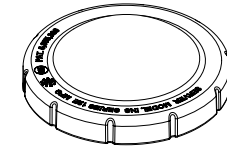
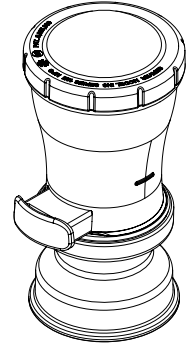
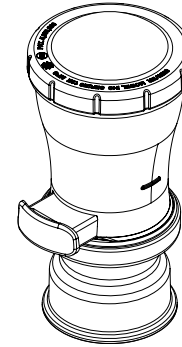

LID

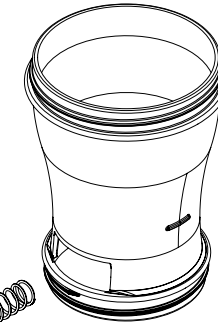

BODY

TRIGGER  
AND  
SPRING  
ASSEMBLY

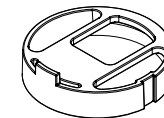
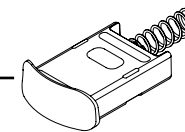

CLOSER PLATE

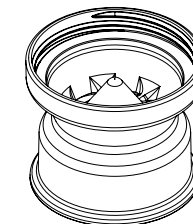

SPREADER

## DISASSEMBLY

ALWAYS CLEAN UNIT THOROUGHLY BEFORE USE. SEE CLEANING.

- 1 REMOVE LID FROM UNIT BODY.
  - Rotate lid counter clockwise to loosen.
- 2 EMPTY PRODUCT FROM UNIT.
  - Tip over and pour product out of unit body.
- 3 REMOVE SPREADER FROM UNIT BODY.
  - Rotate spreader counter clockwise to loosen.
- 4 REMOVE CLOSER PLATE FROM UNIT BODY.
  - Set unit body upside down on countertop, with removable parts on top, to disassemble.
  - Push trigger and spring assembly into unit body until space is available for closer plate rim tab to release from interior space.
  - Pull closer plate, by grasp tab, up and out of unit body.
- 5 REMOVE TRIGGER AND SPRING ASSEMBLY FROM SLOT OF UNIT BODY.
  - Ensure that spring does not spring up and out of unit body.
  - Hold spring as spring compression is released, so that spring doesn't pop out and become lost.

## ASSEMBLY

ALWAYS CLEAN UNIT THOROUGHLY BEFORE EACH USE. SEE DISASSEMBLY AND CLEANING.

Portion Control is preset: 1/3 tsp. for pink and yellow trigger units, and 1/2 tsp. for green trigger units.

- 1 INSTALL TRIGGER AND SPRING ASSEMBLY INTO SLOT OF UNIT BODY.
  - Set unit body upside down on countertop.
  - Install spring end of trigger and spring assembly into slot of unit body first, with trigger portion amount stamp, on inside of trigger, facing upward.
- 2 INSTALL CLOSER PLATE INTO UNIT BODY.
  - Hold closer plate by grasp tab that extrudes out from inside middle of closer plate.
  - Push and depress trigger and spring assembly into unit body slot until closer plate rim tab can install into largest interior space of trigger.
  - Ensure that spring does not spring up and out of unit body.
  - Trigger will not depress if closer plate rim tab is installed into smaller interior spaces of trigger.
  - Also align slot on side of closer plate to slide onto key tab on inside rim of unit body.
- 3 INSTALL SPREADER ONTO UNIT BODY.
  - Rotate spreader clockwise to tighten.
- 4 FILL UNIT WITH PRODUCT TO DISPENSE.
  - Refill with product when product is dispensed down to refill line.
- 5 INSTALL LID ONTO UNIT BODY.
  - Rotate lid clockwise to tighten.

- A Portion Amount Stamp
- B Body Slot
- C Grasp Tab
- D Closer Plate Slot and Body Rim Key Tab
- E Closer Plate Rim Tab
- F Closer Plate Rim Tab installing into Largest Interior Space of Trigger
- G Trigger Assembly installing into Body Slot
- H Trigger Assembly depressed into Body Slot for Closer Plate Rim Tab to install into Largest Interior Space of Trigger
- I Spreader install
- J Spreader rotating clockwise to secure threading to body
- K Lid install and rotating clockwise to secure threading to body
- L Refill Line

## PORTION CONTROL

Set portion control by selecting appropriate trigger assembly. Trigger assembly includes trigger and spring. Trigger part number and portion amount is stamped on inside of each trigger.

\*Portion amount will be incorrect if unit is not filled with product above refill line on unit.

Optional Trigger Assemblies:

Trigger Assembly	Trigger	Color	Portion Amount	Conversion
87126	87093	Green	1/2 tsp.	(.083 oz.) (2.465 mL)
87127	87097	Blue	1/3 tsp.	(.056 oz.) (1.642 mL)
87128	87098	Black	1/4 tsp.	(.042 oz.) (1.233 mL)
87129	87099	White	.15 tsp.	(.025 oz.) (0.739 mL)
87131	87104	Burgundy	1/8 tsp.	(.021 oz.) (0.616 mL)
87132	87105	Tan	1/16 tsp.	(.010 oz.) (0.308 mL)
87133	87108	Pink	1/3 tsp.	(.056 oz.) (1.642 mL)
87134	87109	Yellow	1/3 tsp.	(.056 oz.) (1.642 mL)

## ASSEMBLY

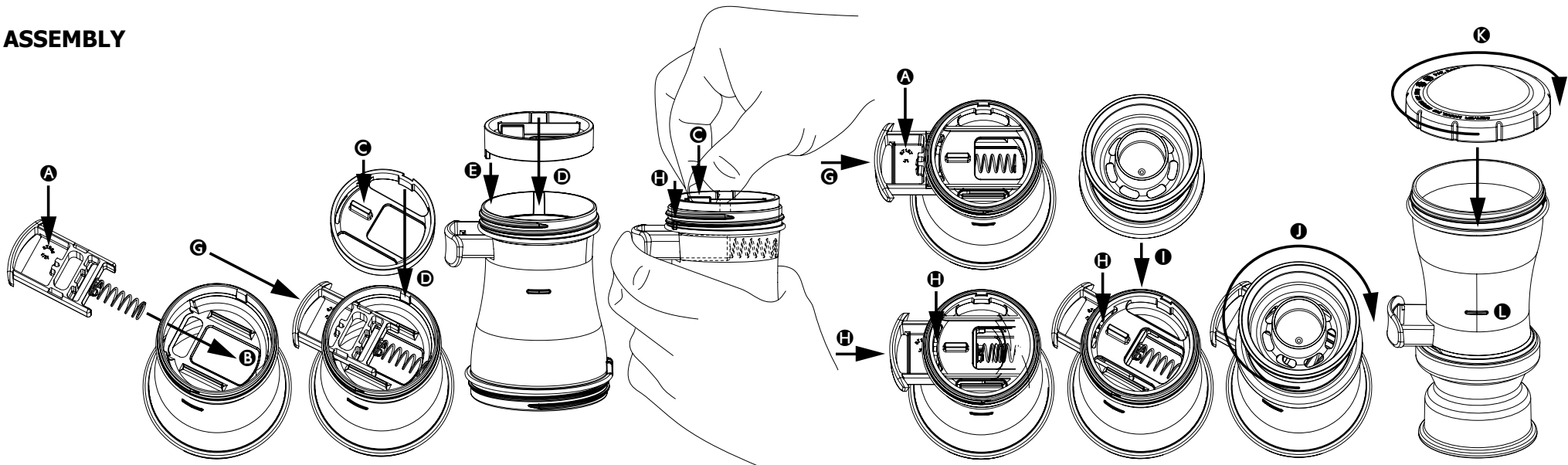

REMOVE SPRING FROM CIRCULAR TAB OF TRIGGER, ONLY IF NECESSARY FOR CLEANING.

- Use a flat head screw driver to pry off spring by pushing straight end of spring away and out of groove in center of circular tab of trigger.

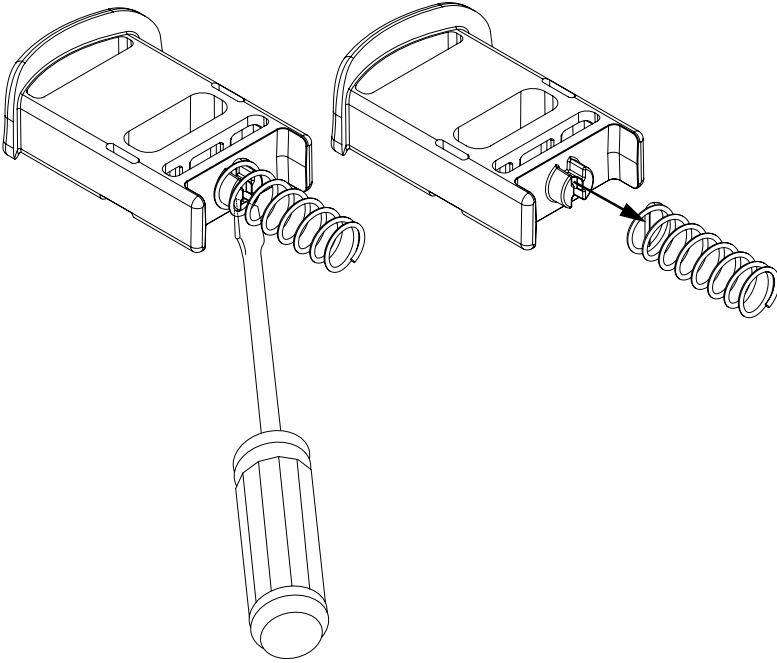

IF REMOVED FROM TRIGGER, RE-INSTALL SPRING ONTO CIRCULAR TAB OF TRIGGER.

- Install straight end of spring into groove in center of circular tab of trigger.
- Use a flat head screw driver to press down on straight end of spring to engage and snap spring into circular tab of trigger.

