



S E R V E R

SERVE BETTER™

SERVER EXPRESS™

MODEL	Description	Series	MODEL Number
SLE-2	SLIM SERVER EXPRESS TWIN	07J	07520
SLE-3	SLIM SERVER EXPRESS TRIPLE	07J	07530
SLE-6	SLIM SERVER EXPRESS SEXTUPLE	07J	07540

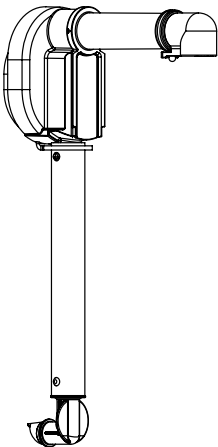
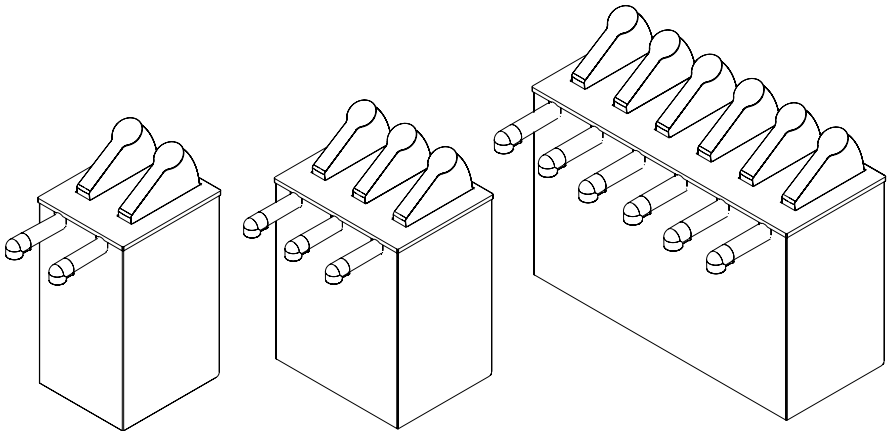

SAFETY GUIDELINES

According to food and safety regulations, most foods must be stored and/or served at certain temperatures or they could become hazardous. Check with local food and safety regulators for specific guidelines.

Be aware of the product you are serving and the temperature the product is required to maintain. Server Products, Inc. can not be responsible for the serving of potentially hazardous product.



NSF International (National Sanitation Foundation) lists this pump as: "Not acceptable for dispensing potentially hazardous foods."

Stainless steel is one of the best materials for food serving and storage, but there are many products which can corrode it. If you notice corrosion beginning on any stainless steel surface, you may need to change the cleansing agent, sanitizing agent, or the cleaning procedures you are using.

- Products containing: acids, alkalines, chlorine, or salt can corrode stainless steel.
- Sauerkraut and Au Jus sauces corrode stainless steel. Server Products, Inc. regrets that we can not honor Warranty claims on stainless steel parts that have been affected by sauerkraut or Aus Jus.

PORTION CONTROL

Portion control is the amount of product which will dispense from pump with each full push of lever. The roller, which is attached to the bottom of the lever, can be adjusted to allow for specific portion control.

How to Set Portion Control

- 1 REMOVE LID FROM UNIT.
- 2 REMOVE ROLLER FROM LEVER BY PULLING HINGE PIN OUT.
- 3 DETERMINE WHICH PIVOT HOLES IN LEVER WILL BE USED TO HOLD ROLLER FOR PORTION DESIRED PER FULL PUSH OF LEVER.

Portion Desired (per full push of lever)	Adjust roller to pivot on lever holes
1 Ounce	A
3/4 Ounce	B
1/2 Ounce	C
1/4 Ounce	D

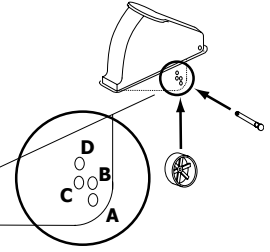

- 4 ALIGN CENTER HOLE OF ROLLER WITH SELECTED PIVOT HOLES ON LEVER.
- 5 INSTALL HINGE PIN THROUGH SELECTED PIVOT HOLE ON ONE SIDE OF LEVER, THROUGH CENTER HOLE OF ROLLER, AND THROUGH COORDINATING PIVOT HOLE ON OTHER SIDE OF LEVER.
 - Push hinge pin through until it securely snaps into place.
- 6 INSTALL LID ONTO UNIT.

UNIT SET-UP

ALWAYS CLEAN UNIT THOROUGHLY BEFORE EACH USE. SEE SAFETY GUIDELINES, UNIT TAKE-DOWN, PUMP DISASSEMBLY, CLEANING, AND PUMP ASSEMBLY.

- 1 SET PORTION CONTROL IF NECESSARY. SEE PORTION CONTROL.
- 2 ASSEMBLE PUMP. SEE PUMP ASSEMBLY.
- 3 ATTACH PUMP TO PRODUCT POUCH.
 - Place product pouch on a counter top with pouch fitment circle facing upward.
 - Remove cap from product pouch.
 - Position pump connector directly over center of pouch fitment circle.
 - Press pump connector down to pierce through film in pouch fitment circle.
 - Pump connector will be fully engaged into pouch fitment when outer top surface of pouch fitment circle touches pump connector rim.
- 4 PRIME PUMP.
 - Apply light pressure on end of product pouch while repeatedly compressing pump dome. Continue to repeat this process until pump is full of product.
- 5 INSTALL PUMP AND PRODUCT POUCH COMBINATION INTO SHROUD.
 - Align pump guides into retaining slot on inside wall of shroud.
- 6 INSTALL LID.
 - Position lid with roller facing near pump dome.

UNIT TAKE-DOWN

- 1 REMOVE LID FROM UNIT.
- 2 REMOVE PUMP (AND ATTACHED PRODUCT POUCH IF UNIT HAS ALREADY BEEN IN USE) FROM SHROUD.
 - If unit has already been in use, disconnect pump from product pouch. Pull pump by connector from product pouch fitment.
- 3 FLUSH AND RINSE ALL INSIDE AND OUTSIDE SURFACES OF PUMP THOROUGHLY WITH HOT WATER.
 - Place lower end of pump into container of hot water and operate pump until all (if any) remaining product is expelled and only hot water flows from discharge tube. Then remove pump from container of water to disassemble.
- 4 DISASSEMBLE AND CLEAN PUMP. SEE PUMP DISASSEMBLY AND PUMP CLEANING.

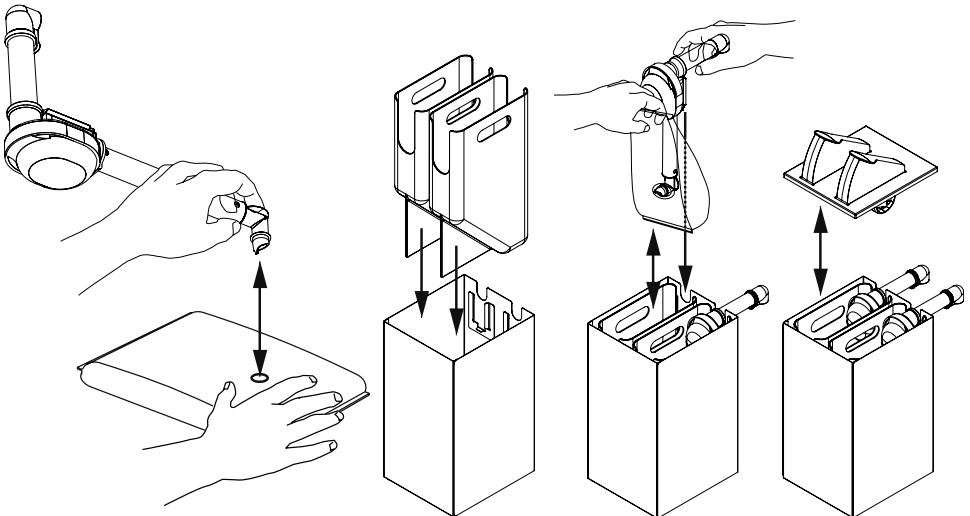

PUMP DISASSEMBLY

- 1 REMOVE CONNECTOR FROM FLEXIBLE PLASTIC TUBE.
- 2 ROTATE AND PULL CONNECTOR AWAY FROM FLEXIBLE PLASTIC TUBE.
- 3 REMOVE FLEXIBLE PLASTIC TUBE FROM BOTTOM OF PUMP HOUSING.
- 4 ROTATE AND PULL FLEXIBLE PLASTIC TUBE AWAY FROM PUMP HOUSING.
- 5 REMOVE PUMP DOME FROM PUMP HOUSING.
- 6 UNHOOK LOOP FROM BOTTOM OF DOME TO RELEASE DOME FROM PUMP HOUSING.
- 7 TAKE PINCH VALVE OUT OF PUMP HOUSING.

PUMP ASSEMBLY

ALWAYS CLEAN PUMP THOROUGHLY BEFORE EACH USE. SEE UNIT TAKE-DOWN, PUMP DISASSEMBLY, PUMP ASSEMBLY, SAFETY GUIDELINES, AND CLEANING.

- 1 INSERT PINCH VALVE INTO PUMP HOUSING.
- 2 INSTALL DOME ONTO PUMP BODY.
 - Align valve flap inside dome to be on top of opening between pump body and pump body discharge tube.
 - Place loop onto pump housing tube to secure dome.
- 3 INSTALL FLEXIBLE TUBE ONTO PUMP BODY SHORT EXTENSION TUBE.
 - Use small amount of water as lubricant when installing flexible tube.
 - Rotate flexible tube onto pump body short extension tube until projections on pump body short extension tube align with holes in flexible tube.
 - Rotate and position flexible tube with connector on opposite end to be pointing away from pump body discharge tube.
- 4 INSTALL CONNECTOR ONTO FLEXIBLE TUBE.
 - Use small amount of water as lubricant when installing connector.
 - Rotate connector into flexible tube until projections on connector align and fall into holes in flexible tube.
- 5 INSTALL DISCHARGE FITTING ONTO PUMP HOUSING DISCHARGE TUBE.
 - Place loop of discharge fitting onto peg on end of discharge tube to secure discharge fitting.

PUMP CLEANING

BEFORE FIRST USE AND AFTER USE DAILY OR REGULARLY, DISASSEMBLE AND CLEAN PARTS. FOR SAFE AND PROPER CARE, AND TO PREVENT CORROSION, OF PARTS, IT IS IMPORTANT TO CLEAN, RINSE, SANITIZE, AND DRY PARTS DAILY OR REGULARLY. FAILURE TO COMPLY WITH ANY OF THESE INSTRUCTIONS MAY VOID UNIT WARRANTY.

- 1 SEE UNIT TAKE DOWN
- 2 FLUSH AND RINSE ALL INSIDE AND OUTSIDE SURFACES OF PUMP THOROUGHLY WITH HOT WATER.
 - Place lower end of pump into container of hot water and operate pump until all (if any) remaining product is expelled and only hot water flows from discharge tube. Then remove pump from container of water to disassemble.
- 3 DISASSEMBLE PUMP. SEE PUMP DISASSEMBLY.
- 4 WASH CLEAN ALL PARTS WITH DISHWASHING DETERGENT AND HOT WATER.
 - Clean all confined areas with any supplied brush(es).
 - Do not use scrapers, steel pads, steel wool, or other cleaning tools that can scratch surfaces.
 - Mildly abrasive NYLON or brass brush may be used to remove any stubborn food or mineral deposits on interior surfaces of unit.
 - Do not use abrasive cleansers.
 - Do not use caustic cleansers.
 - Do not use cleansing agents with high concentrations of acid, alkaline or chlorine.
 - Do not use ammonia based cleansers.
- 5 FULLY RINSE ALL WASHED PARTS THOROUGHLY WITH CLEAR WATER.
 - To prevent corrosion on parts, it is important to thoroughly and fully rinse washed parts.
- 6 SANITIZE ALL PARTS FOLLOWING LOCAL SANITIZATION REQUIREMENTS. ALL PARTS IN CONTACT WITH FOOD MUST BE SANITIZED.
 - Allow parts to fully air dry after sanitization.
 - Dishwasher safe.

PUMP DISASSEMBLY

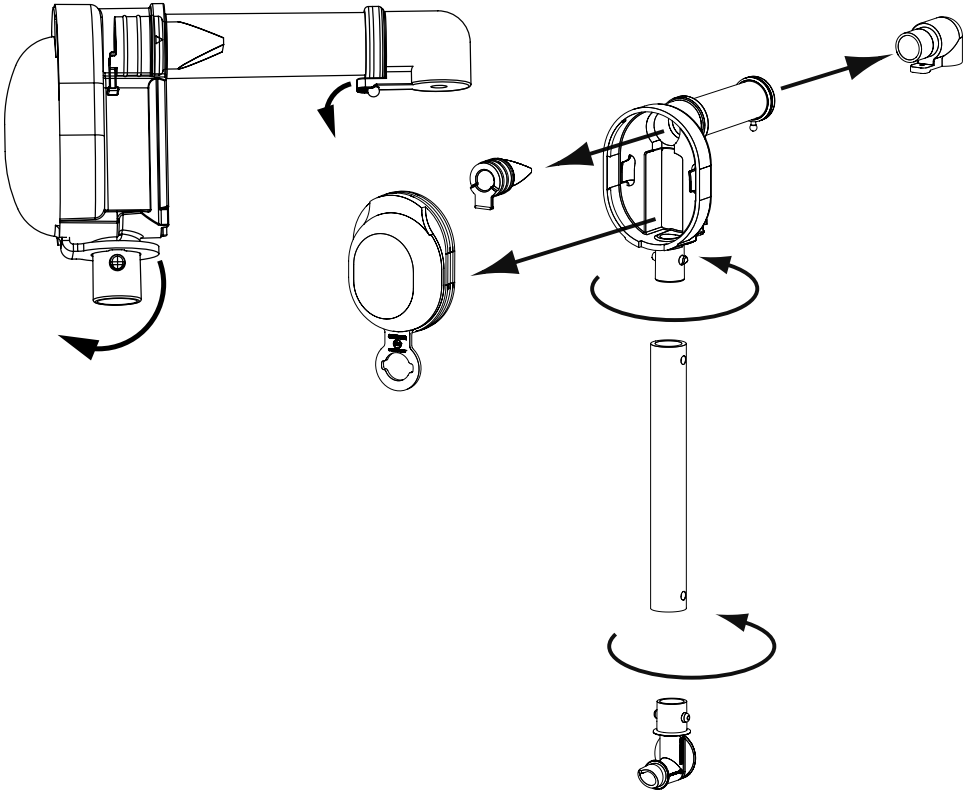

PUMP ASSEMBLY

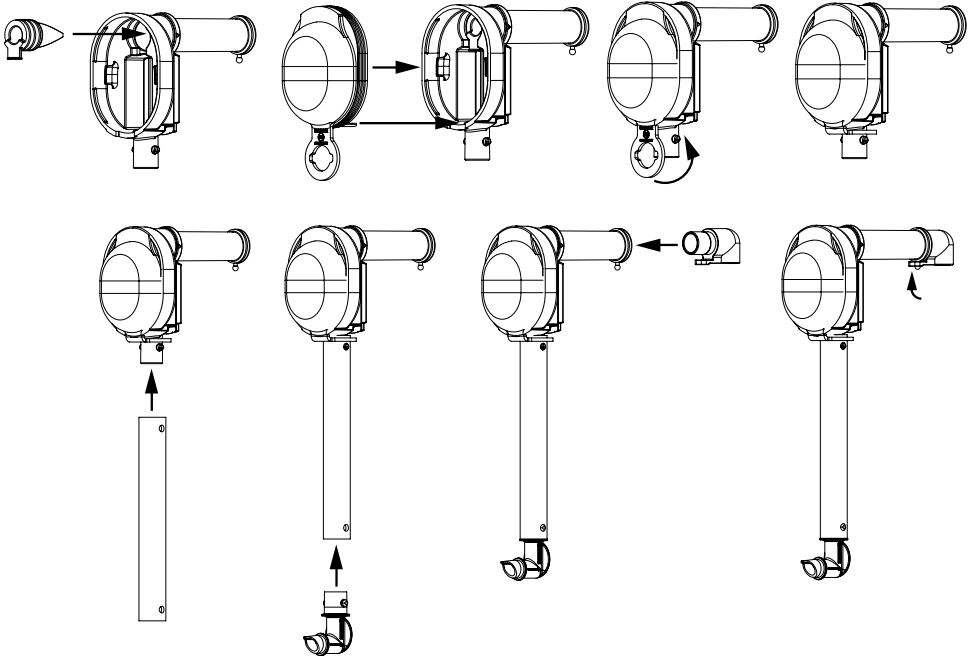

**SERVER EXPRESS™
PUMP, ADA, PINCH VALVE, LONG
07794**

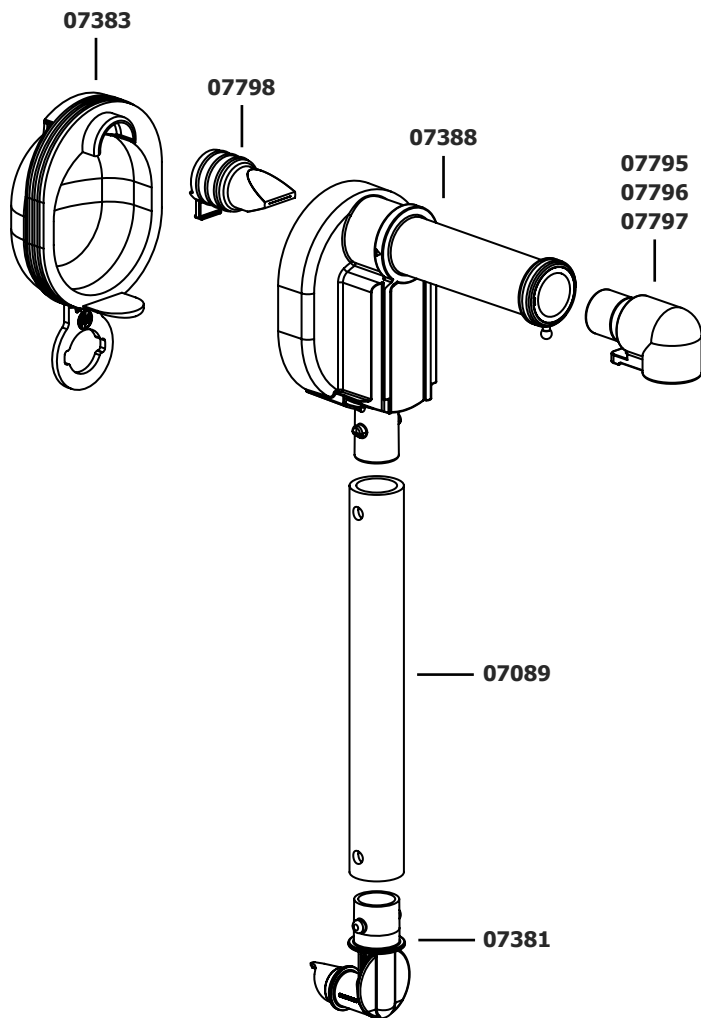

PUMP PARTS LIST

Part	Description
07089	TUBE, PLASTIC, 7"
07381	CONNECTOR, 16MM
07383	DOMES, PUMP, .218, 45-50 DURO
07388	HOUSING, PUMP ASSEMBLY, CLR
07795	FITTING, DISCHARGE, .156-SMALL
07796	FITTING, DISCHARGE, .256-MEDIUM
07797	FITTING, DISCHARGE, .394-LARGE
07798	VALVE, PINCH, ADA PUMP, LARGE

CLEANING UNIT

BEFORE FIRST USE AND AFTER USE DAILY OR REGULARLY, DISASSEMBLE AND CLEAN PARTS. FOR SAFE AND PROPER CARE, AND TO PREVENT CORROSION, OF PARTS, IT IS IMPORTANT TO CLEAN, RINSE, SANITIZE, AND DRY PARTS DAILY OR REGULARLY. FAILURE TO COMPLY WITH ANY OF THESE INSTRUCTIONS MAY VOID UNIT WARRANTY.

SEE PUMP DISASSEMBLY AND PUMP CLEANING FOR PUMP INSTRUCTIONS.

- 1 SEE UNIT TAKE DOWN.
- 2 WASH CLEAN ALL PARTS WITH DISHWASHING DETERGENT AND HOT WATER.
 - Do not use scrapers, steel pads, steel wool, or other cleaning tools that can scratch surfaces.
 - Mildly abrasive NYLON or brass brush may be used to remove any stubborn food or mineral deposits on interior surfaces of unit.
 - Do not use abrasive cleansers.
 - Do not use caustic cleansers.
 - Do not use cleansing agents with high concentrations of acid, alkaline or chlorine.
 - Do not use ammonia based cleansers.
- 3 FULLY RINSE ALL WASHED PARTS THOROUGHLY WITH CLEAR WATER.
 - To prevent corrosion on parts, it is important to thoroughly and fully rinse washed parts.
- 4 WIPE CLEAN EXTERNAL SURFACES OF UNIT WITH A CLEAN DAMP CLOTH.
 - Nontoxic glass cleaner may be used to clean stainless steel parts.
- 5 DRY ALL PARTS WITH A CLEAN SOFT CLOTH.
 - Various elements and minerals, such as chlorides in tap water, can accumulate on stainless steel parts and create corrosion.
 - To prevent corrosion on stainless steel parts, it is important to thoroughly and fully dry with a clean soft cloth regularly.
- 6 SANITIZE ALL PARTS FOLLOWING LOCAL SANITIZATION REQUIREMENTS. ALL PARTS IN CONTACT WITH FOOD MUST BE SANITIZED.
 - Allow parts to fully air dry after sanitization.

UNIT TROUBLESHOOTING

Possible Problems:

- Pump dispenses little or no product.
- Portion control is not consistent.

Possible Solutions:

- Clean pump.
- Ensure product pouch is not empty.
- Ensure product pouch is installed correctly.
- Ensure roller is properly installed on lever.
- Ensure flap inside pump dome and pinch valve are properly positioned when assembling pump.
- Ensure pump is installed into retaining slot on inside front wall of unit.

GENERAL SERVICE, REPAIR, OR RETURNS

Before sending any item to Server Products for service, repair, or return, contact Server Products customer service to request a **Return Authorization Number**. Merchandise must be sent to Server Products with this number.

Merchandise being returned for credit must be in new and unused condition and not more than 90 days old and will be subject to a 20% (percent) restocking charge. Electrical parts (thermostats, heating elements, etc.) are not returnable.

Server Products maintains a fully staffed service department with highly skilled factory trained personnel. Service is extremely prompt. Under normal circumstances, a repaired unit is shipped out the day after it is received. Labor charges are reasonable.

SERVICE

Contact your dealer or Server Products Inc. customer service department for the following:

ORDERING REPLACEMENT PARTS







Be prepared to give this information:

- Model Letters/Name/Numbers
- Part Numbers- P/N
- Series Numbers/Letters
- Part Description

This information and other important data is stamped on the lid or cylinder of pumps or on the bottom or back side of every unit.

SERVER PRODUCTS LIMITED WARRANTY

All Server Products equipment is backed by a two-year limited warranty against defects in materials and workmanship. For complete warranty information go to: www.server-products.com

	Server Products Inc. 3601 Pleasant Hill Road Richfield, WI 53076 USA
	262.628.5600
	800.558.8722
	262.628.5110
	spsales@server-products.com
	www.server-products.com