



01688-REVA_080414_PORTUGUESE

(01688 is 01834 translated)

S E R V E R

SERVE BETTER™

MODEL:

TWIN FOOD SERVER/FOOD SERVER WITH PUMP

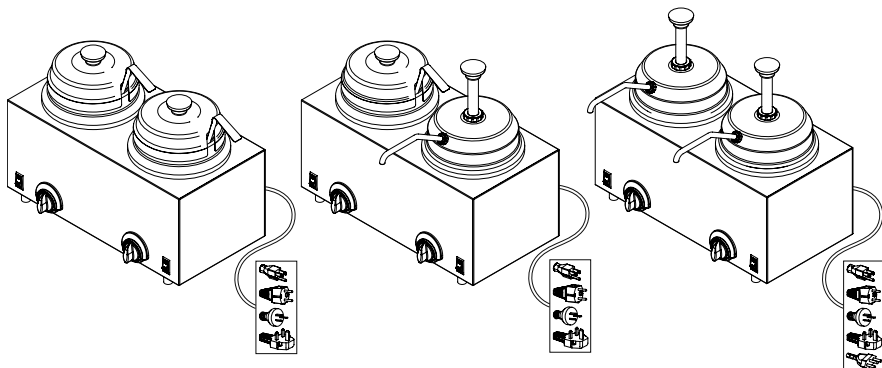

TWIN FS

120V
Series 13C
81220

230V Continental Europe
Series 13C
81250

230V Australia
Series 13C
81420

230V United Kingdom
Series 13C
84910

TWIN FS/FSP

120V
Series 13C
81290

230V Continental Europe
Series 13C
80280

230V Australia
Series 13C
80850

230V United Kingdom
Series 13C
84950

TWIN FSP

120V
Series 13C
81230

230V Continental Europe
Series 13C
81260

230V Australia
Series 13C
81460

230V United Kingdom
Series 13C
84990

230V Brazil
Series 13C
86943

SAFETY GUIDELINES WHEN USING THIS UNIT:

  **Warning- Electrical shock could occur:**

- This unit must be earthed or grounded.
- This requires all three prongs (terminals) on cord plug to be plugged into power source.

According to food and safety regulations, most foods must be stored and/or served at certain temperatures or they could become hazardous. Check with local food and safety regulators for specific guidelines.

Be aware of the product you are serving and the temperature the product is required to maintain. Server Products, Inc. can not be responsible for the serving of potentially hazardous product.

Stainless steel is one of the best materials for food serving and storage, but there are many products which can corrode it. If you notice corrosion beginning on any stainless steel surface, you may need to change the cleansing agent, sanitizing agent, or the cleaning procedures you are using.

- Products containing: acids, alkalines, chlorine, or salt can corrode stainless steel.
- Sauerkraut and Au Jus sauces corrode stainless steel. Server Products, Inc. regrets that we can not honor Warranty claims on stainless steel parts that have been affected by sauerkraut or Au Jus.

SAFETY GUIDELINES WHEN CLEANING THIS UNIT:

Ensure unit is "OFF" and unplugged.

 **Caution- Hot:**

- If unit has already been in use, unit may still be hot. Allow unit to cool before continuing.

  **Warning- Electrical shock could occur:**

- Electrical components of unit could be damaged from water exposure or any liquid.
- Never immerse unit into water or any liquid.
- Never use any water jet or pressure sprayer on unit.

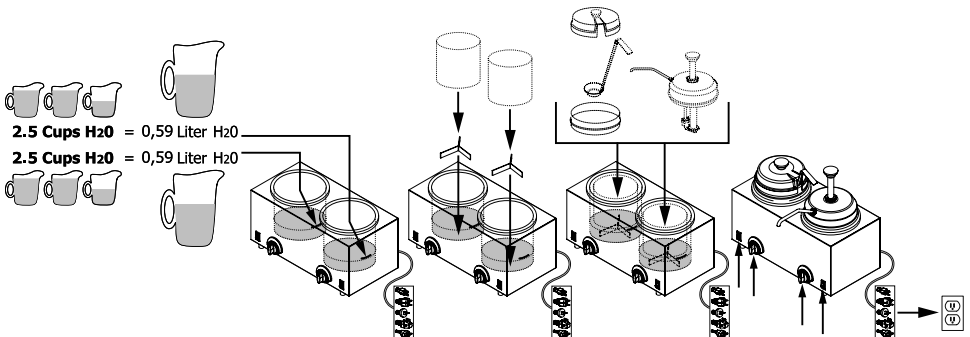

UNIT SET-UP

ALWAYS CLEAN UNIT (AND PUMPS) THOROUGHLY BEFORE EACH USE. SEE UNIT TAKE-DOWN, SAFETY GUIDELINES AND CLEANING. SEE SEPARATE PUMP MANUAL FOR PUMP INSTRUCTIONS.

- 1 FILL WATER VESSEL BASINS OF UNIT WITH WATER.
 - Fill to embossed water level line inside water vessel basin
 - 2.5 cups (20 oz) water
 - DO NOT OVER FILL.
- 2 INSTALL SPACERS AND PRODUCT TINS(#10 CANS) OR STAINLESS STEEL JARS INTO WATER VESSEL BASINS.
 - Product being served must always be inside product tin(#10 can) or stainless steel jar and never placed directly into water vessel.
- 3 INSTALL PUMP(S) OR LID(S) AND ADAPTER(S) INTO/ONTO PRODUCT TINS(#10 CANS) OR STAINLESS STEEL JARS.
- 4 PLUG CORD INTO POWER SOURCE.
- 5 PRESS SWITCH(ES) TO THE "ON" POSITION.
- 6 SET THERMOSTAT KNOBS TO RECOMMENDED PRODUCT SERVING TEMPERATURES.
 - To heat unit faster, thermostat knobs may be rotated to maximum setting TEMPORARILY.

Server Products Inc. claims no responsibility for actual serving temperature of product. It is the responsibility of the user to ensure that any product is held and served at a safe temperature.

FOR PRODUCTS BEING SERVED WHICH REQUIRE RETHERMALIZATION OR NEED TO ACHIEVE SAFE HOT FOOD HOLDING, SEE RETHERMALIZATION AND HOT FOOD HOLDING.

RE THERMALIZATION AND HOT FOOD HOLDING



(National Sanitation Foundation)
NSF International and
(American National Standards Institute)
ANSI list this unit as a "Rethermalization
and Hot Food Holding unit (Standard 4)"

Rethermalization of food products is achieved by this appliance when it elevates the food product temperature from a refrigerated 40°F (4°C) to a safe food cooked temperature of 165°F (74°C) within a period of 2 hours.

Hot Food Holding is achieved with this appliance when it maintains a product temperature at or above 150°F (66°C), in all locations throughout the product, for a minimum of 2 hours, even if any lid, cover, or pump is removed. The lid, cover, or pump is recommended to help maintain product temperature.

PRE-HEAT FOR AT LEAST 30 MINUTES WITH:

- correct amount of water in water vessel basins
- pump(s) or lid(s) installed
- thermostat knob(s) set at maximum setting

MAXIMUM CAPACITY OF FOOD PRODUCT MUST BE LIMITED TO:

- 96 oz. (#10 can) or 3 quarts (12 cups)
- DO NOT OVER FILL.

AFTER PRE-HEAT:

- Thermostat knob must remain set at maximum setting for entire duration of Hot Food Holding

UNIT TAKE-DOWN

- 1 PRESS SWITCHES TO "OFF" POSITION.
- 2 UNPLUG CORD.



Caution- Hot:

- If unit has already been in use, unit may still be hot. Allow unit to cool before continuing.
- 3 REMOVE PUMP(S) OR LID(S) AND ADAPTER(S) FROM PRODUCT TINS(#10 CANS) OR STAINLESS STEEL JARS.
 - 4 REMOVE PRODUCT TINS(#10 CANS) OR STAINLESS STEEL JARS AND SPACERS FROM WATER VESSEL BASINS.
 - 5 EMPTY WATER OUT OF WATER VESSEL BASINS.
 - Tip unit over a drain to pour water out.

SEE SEPARATE PUMP MANUAL FOR PUMP INSTRUCTIONS.

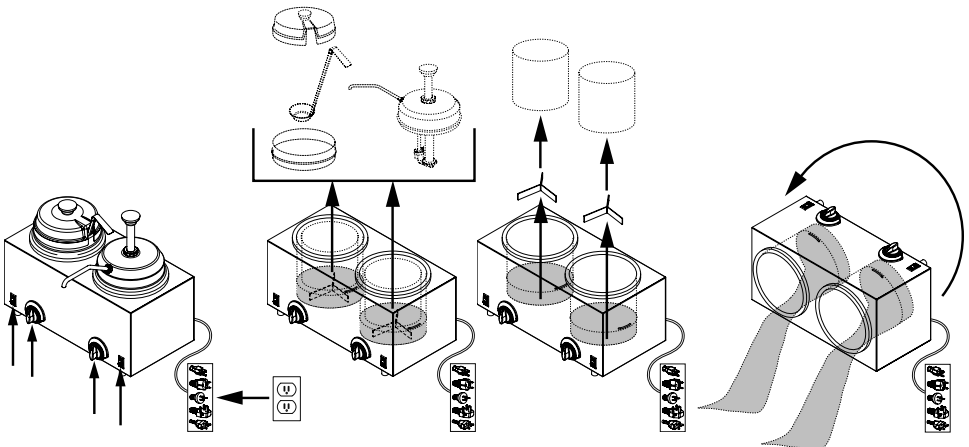

UNIT CLEANING

BEFORE FIRST USE AND AFTER USE DAILY OR REGULARLY. DISASSEMBLE AND CLEAN PARTS. FOR SAFE AND PROPER CARE, AND TO PREVENT CORROSION, OF PARTS, IT IS IMPORTANT TO CLEAN, RINSE, SANITIZE, AND DRY PARTS DAILY OR REGULARLY. FAILURE TO COMPLY WITH ANY OF THESE INSTRUCTIONS MAY VOID UNIT WARRANTY.

- 1 SEE UNIT TAKE DOWN. SEE SEPARATE PUMP MANUAL FOR PUMP INSTRUCTIONS.
- 2 ENSURE UNIT IS "OFF" AND UNPLUGGED.

  **Warning- Electrical shock could occur:**

- **Electrical components of unit could be damaged from water exposure or any liquid.**
 - **Never immerse unit into water or any liquid.**
 - **Never use any water jet or pressure sprayer on unit.**
- 3 WASH ALL REMOVABLE PARTS WITH DISHWASHING DETERGENT AND HOT WATER. RINSE THOROUGHLY AND DRY WITH A CLEAN SOFT CLOTH.
 - A general purpose, nonabrasive cleaner may be used on hard to remove food deposits.
 - A mildly abrasive NYLON or brass brush may be used to remove any stubborn food or mineral deposits on interior surfaces of unit.
 - Do not use abrasive cleansers, scrapers, steel pads, steel wool, or other cleaning tools that can scratch surfaces.
 - Do not use caustic cleansers nor cleansing agents with high concentrations of acid, alkaline or chlorine. These agents can corrode metal parts.
 - Fully rinsing all parts can help prevent corrosion.
 - Various elements and minerals, such as chlorides in tap water, can accumulate on stainless steel parts and create corrosion.
 - To prevent corrosion on any stainless steel parts, it is important to fully dry with a clean soft cloth regularly.
 - 4 WIPE EXTERNAL SURFACES OF UNIT WITH A CLEAN DAMP CLOTH. DRY WITH A CLEAN SOFT CLOTH.
 - A nontoxic glass cleaner may be used for cleaning any stainless steel parts.
 - 5 SANITIZE ALL PARTS FOLLOWING LOCAL SANITIZATION REQUIREMENTS. ALL PARTS IN CONTACT WITH FOOD MUST BE SANITIZED.
 - Allow parts to fully air dry after sanitization.

UNIT TROUBLESHOOTING

Possible Problem:

- Unit does not heat.

Possible Solutions:

- Ensure cord is securely plugged in.
- Ensure power is available from source.
- Ensure unit is on.
- Ensure thermostat knobs are set correctly.

GENERAL SERVICE, REPAIR, OR RETURNS

Before sending any item to Server Products for service, repair, or return, contact Server Products customer service to request a **Return Authorization Number**. Merchandise must be sent to Server Products with this number.

Merchandise being returned for credit must be in new and unused condition and not more than 90 days old and will be subject to a 20% (percent) restocking charge. Electrical parts (thermostats, heating elements, etc.) are not returnable.

Server Products maintains a fully staffed service department with highly skilled factory trained personnel. Service is extremely prompt. Under normal circumstances, a repaired unit is shipped out the day after it is received. Labor charges are reasonable.

SERVICE

Contact your dealer or Server Products Inc. customer service department for the following:

ORDERING REPLACEMENT PARTS

Be prepared to give this information:

- Model Letters/Name/Numbers
- Part Numbers- P/N
- Series Numbers/Letters
- Part Description

This information and other important data is stamped on the lid or cylinder of pumps or on the bottom or back side of every unit.

Servicing Cord

Specific tools are required for safe and proper power supply cord removal and installation. If cord must be replaced, only a representative of the OEM (original equipment manufacturer) or a qualified technician may replace cord. Cord must meet code designation H05 RN-F requirements.

SERVER PRODUCTS LIMITED WARRANTY

All Server Products equipment is backed by a two-year limited warranty against defects in materials and workmanship. For complete warranty information go to: www.server-products.com



Server Products Inc.

3601 Pleasant Hill Road
Richfield, WI 53076 USA



262.628.5600



800.558.8722



262.628.5110



spsales@server-products.com



www.server-products.com