

Technical Manual and Replacement Parts List

Manual Defrost Refrigerator



MODEL SKTTR7

SILVER KING REFRIGERATION INC.

1600 Xenium Lane North, Minneapolis, MN 55441-3787
Phone (763) 923-2441

SILVER KING[®]

Specifications Subject to Change With out Notice.

TECHNICAL MANUAL

SILVER KING MODEL SKTTR7 MANUAL DEFROST REFRIGERATOR

Thank you for purchasing Silver King food service equipment. Our goal is to provide our customers with the most reliable equipment in the industry today. Please read this manual and the accompanying warranty information before operating your new Silver King unit. Be sure to complete and mail the warranty card within 10 days of purchase to validate your warranty.

INSPECT FOR DAMAGE AND UNCRATE

Upon delivery of your new Silver King unit, uncrate at once to inspect for possible damage following the instructions printed on the exterior of the container. Report any damages to the carrier responsible for transportation and promptly present a claim for any evidence of mishandling.

INSTALLATION

The stainless steel exterior of the cabinet has been protected by a plastic covering during manufacturing and shipping. This covering can be readily stripped before installation. After removing this covering, wash the interior and exterior surfaces using a warm, mild soapy water solution and a sponge or cloth.

Legs/Casters

The unit comes with Legs or Casters. To install them, tip the unit on to its side and thread the Legs or Casters into the 4 Rivnuts in the base of the unit. Make sure that they are installed tightly to prevent future thread wear.

Shelves

Packaged with the unit you will find two Shelves. The Shelves fit in the unit on the ribs on the side walls and are adjustable to numerous positions.

Door Adjustment and Swing

Should the Door ever require straightening, loosen the Screws on the Hinges, square the Door with the cabinet and retighten the Screws.

The mounting of the door is easily reversible should space requirements demand that you do so. Simply remove the 3 Screws holding each Hinge in place, rotate the Door 180 degrees and relocate the Hinges in the corner opposite their original location.

Location

When locating your new refrigerator or freezer, convenience and accessibility are important considerations, but the following installation guidelines must be followed;

*Always avoid placing the unit adjacent to an oven, heating element or hot air source that would affect the operation of the unit.

*For proper ventilation the unit requires the following minimum clearances:

- 3 inches on sides and 4 inches above the cabinet
- 6 inches behind the cabinet
- must be on legs or casters

*The unit must be level or tilted backwards slightly.

Electrical Connections

Be sure to check the data plate, located on the liner of the cabinet, for required voltage prior to connecting the unit to power. The specifications on the data plate supersede any future discussion.

The standard unit is equipped with an eight (8) foot power cord that requires a 115 Volt, 60 Cycle, 1 Phase **properly grounded** electrical receptacle. The power cord comes with a 3 prong plug for grounding purposes. Any attempt to cut off the grounding spike or to connect to an ungrounded adapter plug will void the warranty, terminate the manufacturers responsibility and could result in serious injury.

The circuit must be protected with a 15 or 20 ampere fuse or breaker. The unit must be isolated on a circuit and not plugged into an extension cord.

OPERATION

Initial start up

After satisfying the installation requirements, the unit is ready to start. The Compressor will start when the power cord is connected to the required power source. If the Compressor does not start when the unit is initially plugged in, check to make sure that the Temperature Control is not in the "off" position. Allow the unit to run for two hours before loading it with product.

Temperature Control

The Temperature Control is located on the back of the cabinet and is factory set to maintain an average cabinet temperature of approximately 38 to 42 Deg F. on the refrigerator. To obtain colder temperatures turn the Temperature Control knob clockwise and vice versa. Allow the unit a minimum of one hour to respond to a control setting adjustment.

Defrost

Your Silver King refrigerator is a manual defrost unit. The unit should be defrosted whenever the frost layer on the evaporator plate is approximately 1/2 inch thick. To defrost the unit, either turn the Temperature Control knob to the 'off' position or disconnect the power cord from the electrical receptacle and prop open the Door. After the frost has melted or come loose, wipe out the cabinet interior. **Do not** attempt to scrape or chisel off the frost as you could do irreparable damage to the unit. You may find it helpful to lay a dry towel in the bottom of the unit to catch the defrost water as it drips down.

MAINTENANCE

Preventative maintenance is minimal although these few steps are very important to continued operation and maximizing the life of the appliance.

Cabinet Surfaces

The cabinet interior is impact resistant ABS plastic and the exterior is stainless steel. These surfaces should be cleaned periodically with a solution of warm water and mild soap and wiped dry with a soft cloth. Should a surface become stained or discolored, do not attempt to clean with an abrasive cleanser or scouring pad. Use a soft cleanser and rub with the grain of the metal to avoid scratching the surface. Do not use chlorinated cleaners on the stainless steel.

Condenser

Periodically, accumulated dust must be removed from the condenser. First, disconnect the unit from the power supply. Remove the Back Panel. To clear the dust, vacuum or brush the condenser at the rear of the cabinet. This will need to be done regularly to maintain the compressor warranty!

P/N 23992

MODEL _____ SERIAL NO. _____ DATE INSTALLED _____

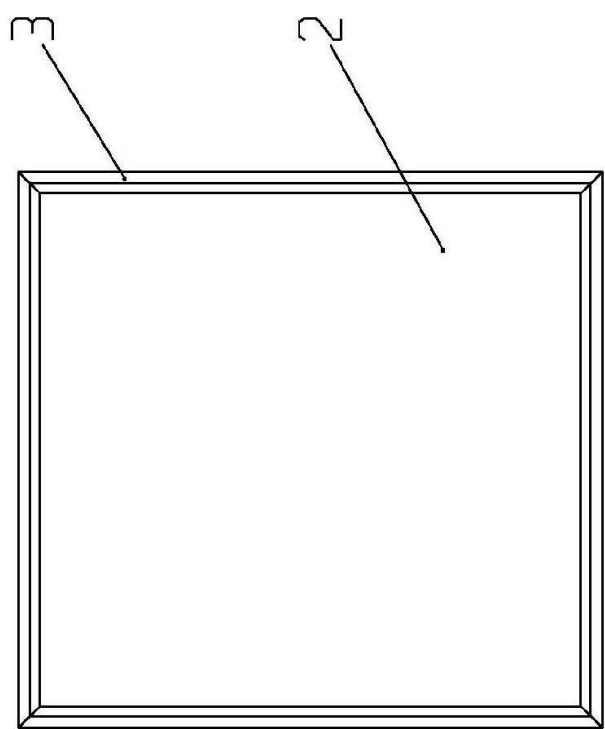
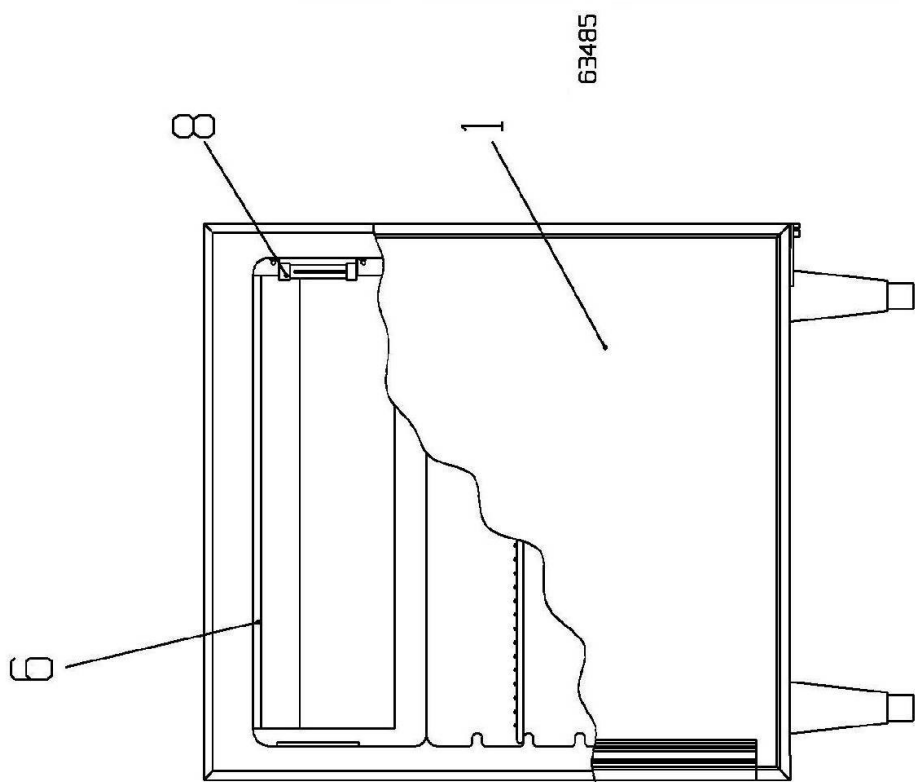

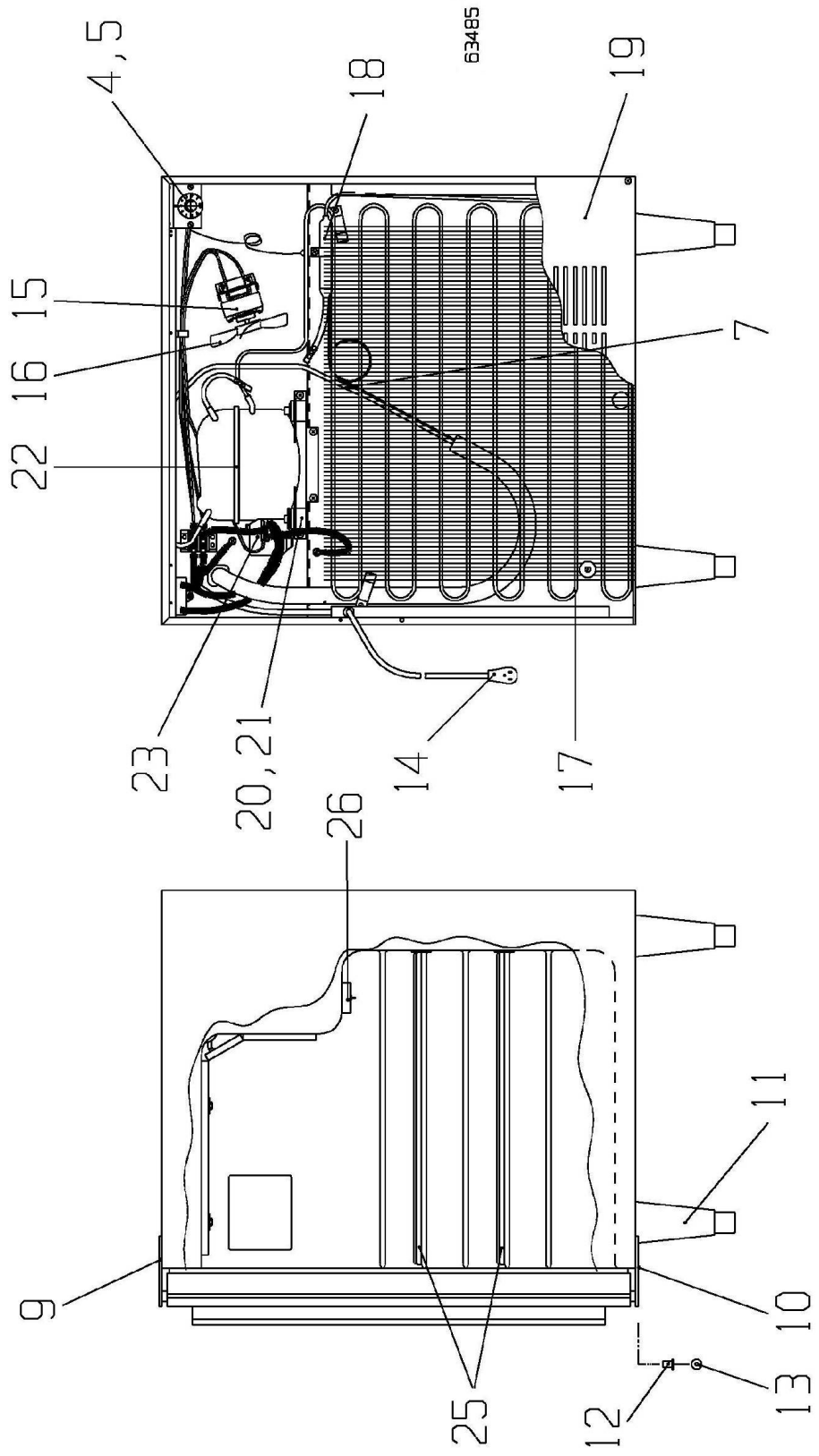

PARTS LIST - 63485

ITEM NO.	PART DESCRIPTION	PART NO.
1	DOOR, COMPLETE SS	60669
2	DOOR LINER	10309-01
3	DOOR GASKET	10310-04
4	KNOB TEMPERATURE CONTROL (20651)	23163
5	TEMPERATURE CONTROL	42929
6	ASSY LO SIDE SKTTR7	60712
7	HEAT EXCHANGER	40768
8	THERMOMETER	22409
9	HINGE (RIGHT TOP/LEFT BOTTOM)	23176
10	HINGE (RIGHT BOTTOM/LEFT TOP)	23175
11	KIT 6 IN LEG (4)	10314-57
12	DOOR BUSHING	20703
13	DOOR WASHER	20702
14	POWER CORD 115V	22099
15	FAN MOTOR 115V	21251-2
16	FAN BLADE 5 IN CW	99196
17	CONDENSER COIL	63028
18	DRIER	22677
19	BACK PANEL	62950
20	GROMMET	20363
21	CLIP HAIRPIN	98106
22	KIT COMPRESSOR 115V	10343-09
23	KIT ELECTRICALS 115V EM40SC	10344-09
25	SHELF WIRE	40751
26	COVER BULB	43056
*WHEN ORDERING REPLACEMENT PARTS, PLEASE PROVIDE MODEL AND SERIAL NUMBER		

SEE SERIAL PLATE FOR CORRECT POWER SOURCE
115VAC, 60HZ, 1 PHASE

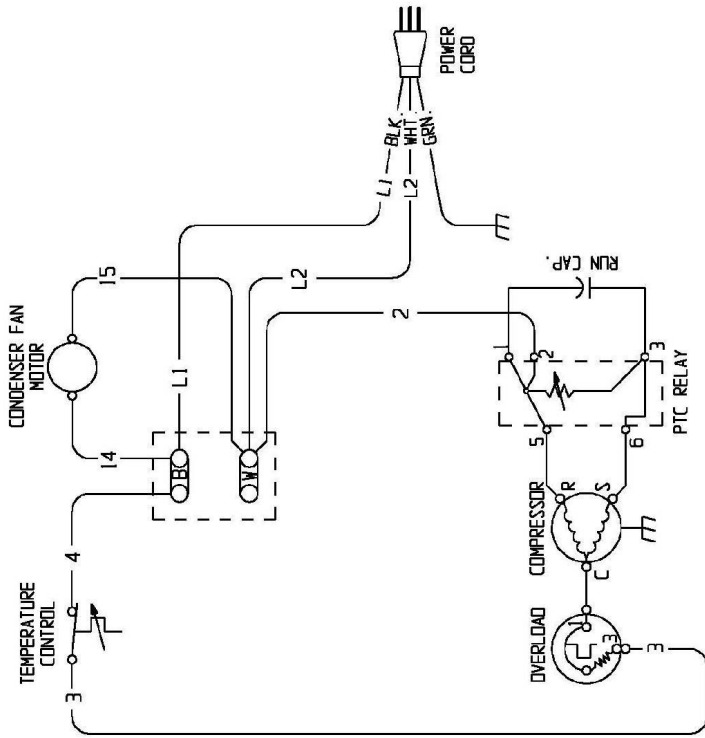
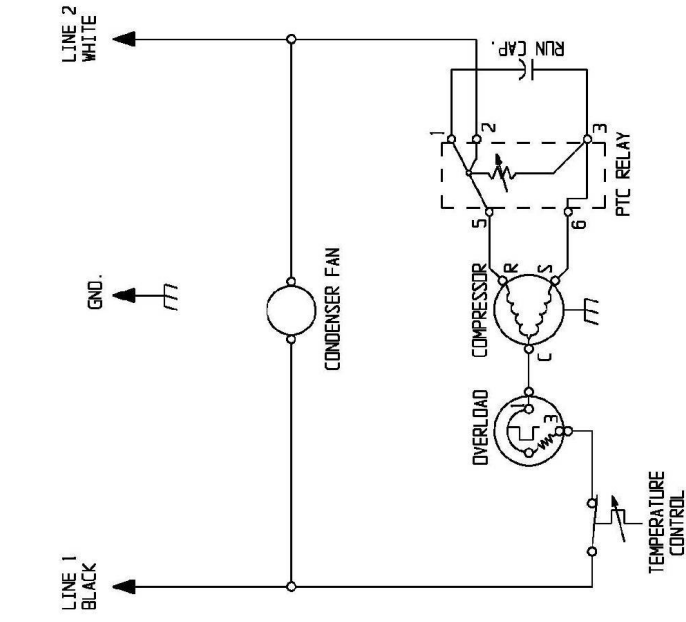

63516 REV A

WIRING DIAGRAM
MODEL: SKTR7
115V