

Technical Manual & Replacement Parts List

Freezer

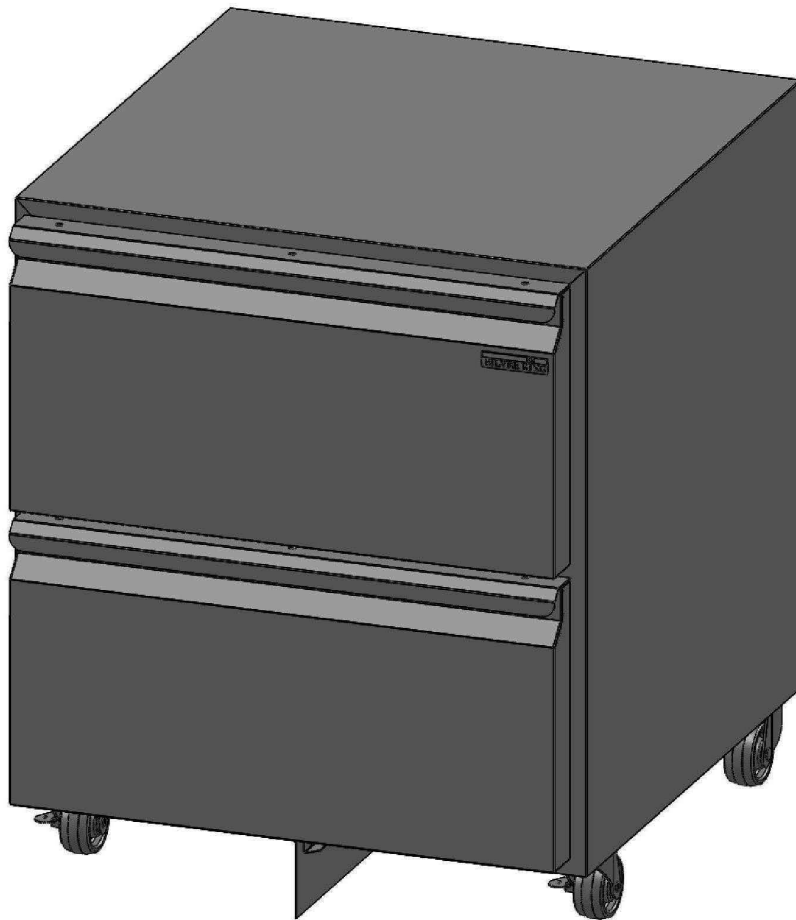

MODEL: DEFF-27D2

1600 Xenium Lane North, Minneapolis, MN 55441-3787
Phone (763) 923-2441

SILVER KING[®]

FORM NO. 39390 REV A 12/2015

Specifications Subject to Change Without Notice.



TECHNICAL MANUAL
SILVER KING FRONT BREATHING FREEZER
MODEL DEFF-27D2

Thank you for purchasing Silver King food service equipment. Our goal is to provide our customers with the most reliable equipment in the industry today. Please read this manual and the accompanying warranty information before operating your new Silver King unit. Be sure to complete and mail the warranty card within 10 days of purchase to validate your warranty.

INSPECT FOR DAMAGE AND UNCRATE

Upon delivery of your new Silver King unit, uncrate at once to examine and test for possible damage following the instructions printed on the exterior of the container. Report any damages to the carrier responsible for transportation and promptly present a claim for any evidence of mishandling. Save all packaging materials if a claim must be filed.

INSTALLATION

The stainless steel exterior of the cabinet has been protected by a plastic covering during manufacturing and shipping. This covering can be readily stripped before installation. After removing this covering, wash the interior and exterior surfaces using a warm, mild soapy water solution and a sponge or soft cloth. Rinse afterward with clean water and wipe dry. Do not use chlorinated cleaners.

Location:

When locating your new Silver King unit, convenience and accessibility are important considerations, but the following installation guidelines must be observed;

- Always avoid locating the unit adjacent to an oven, heating element or hot air source which could adversely affect the performance of the unit.
- The unit must be level.
- For proper ventilation, the bottom front of the unit must not be obstructed.

Legs/Casters:

Models without a base come with Legs or Casters. To install them, tilt the unit and thread the Legs or Casters into the four Rivnuts in the bottom of the cabinet. Make sure that they are installed tightly to prevent future thread wear.

Drawers:

To remove the Drawers on the drawer models for cleaning, simply open them fully, push the stop levers out of the way on the Cabinet Drawer Tracks while pulling the Drawer out. To reinstall the Drawer, line up the Drawer Tracks on the cabinet and the Drawer and push the Drawer into the cabinet. The Drawer Pan can be removed by lifting it out with the Drawer extended.

Electrical Connections:

Be sure to check the data plate, located on the liner of the cabinet, for required voltage prior to connecting the unit to a power source. The specifications on the data plate supersede any future discussion.

The standard unit is equipped with an eight (8) foot power cord that requires a 115 Volt, 60 Cycle, 1 Phase **properly grounded** electrical receptacle. The power cord comes with a 3 prong plug for grounding purposes. Any attempt to cut off the grounding spike or to connect to an ungrounded adapter plug will void the warranty, terminate the manufacturers responsibility and could result in serious injury.

The circuit must be protected with a 15 or 20 ampere fuse or breaker. The unit must be isolated on a circuit and not plugged into an extension cord.

OPERATION

Initial Start Up:

After satisfying the installation requirements, the unit is ready to start. The unit will start when the power cord is connected to the required power source. If the compressor does not start when the unit is initially plugged in, check to make sure that the temperature control is not in the 'off' position. Allow the unit to run a minimum of two hours before loading it with product. When loading the unit with product, take care not to block the air flow at the back of the cabinet as this would affect the performance of the cabinet.

Temperature Control

The Temperature Control is located on the back of the cabinet and is factory set to maintain an average cabinet temperature of approximately 0 Deg F. To obtain colder temperatures, press and hold the set button until the set point value flashes. Use the up or down arrow buttons to change the value and then press the set button again. Allow the unit a minimum of one hour to respond to a control setting adjustment.

Defrost:

Your Silver King unit is an automatic defrost unit. No additional plumbing is required. Automatic defrosting is accomplished by a defrost heater and timer. Defrost water is collected in a pan located in the compressor compartment where it is evaporated into the room air. It is important that the unit be level so the condensate can drain properly.

MAINTENANCE

Preventative maintenance is minimal although these few steps are very important to continued operation and maximizing the life of the appliance.

Cabinet Surfaces:

The cabinet interior is aluminum and the exterior is stainless steel. These surfaces should be cleaned periodically with a solution of warm water and mild soap. After cleaning the surfaces, they should be rinsed with clean water and wiped dry with a soft cloth. Stainless steel cleaners can be used on the exterior. Should a surface become stained, do not attempt to clean with an abrasive cleaner or scouring pad. Use a soft cleanser and rub with the grain of the metal to avoid scratching the surface. Always rinse well and dry after cleaning. Do not use chlorinated cleaners.

Condenser

Periodically, accumulated dust must be removed from the condenser. First, disconnect the unit from the power supply. To clear the dust, vacuum or brush the condenser at the bottom rear of the cabinet. This will need to be done regularly to maintain the compressor warranty!

Drawer Gasket

The Drawer Gasket will collect dirt and should be wiped clean with a warm, mild soapy water solution to extend its life and assure maximum cabinet performance and life.

MODEL _____ SERIAL NO. _____ DATE INSTALLED _____

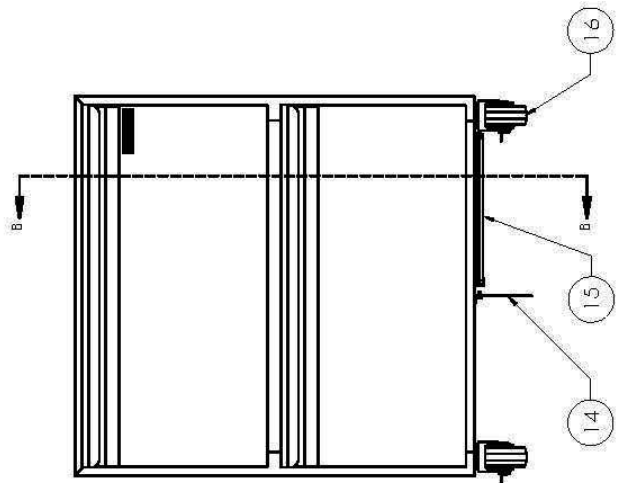
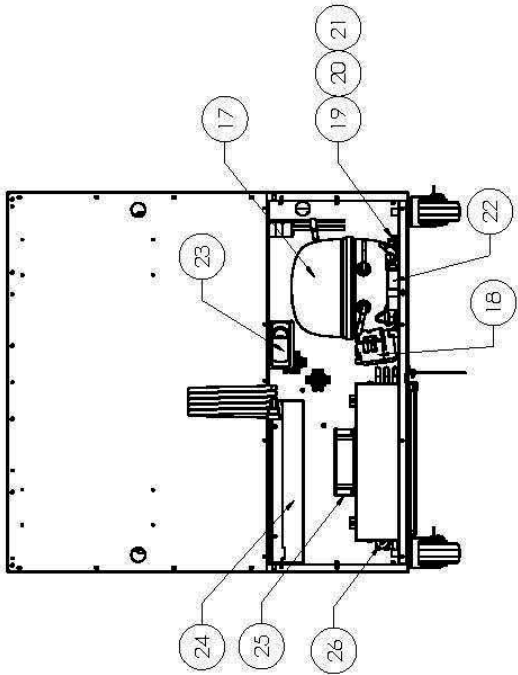
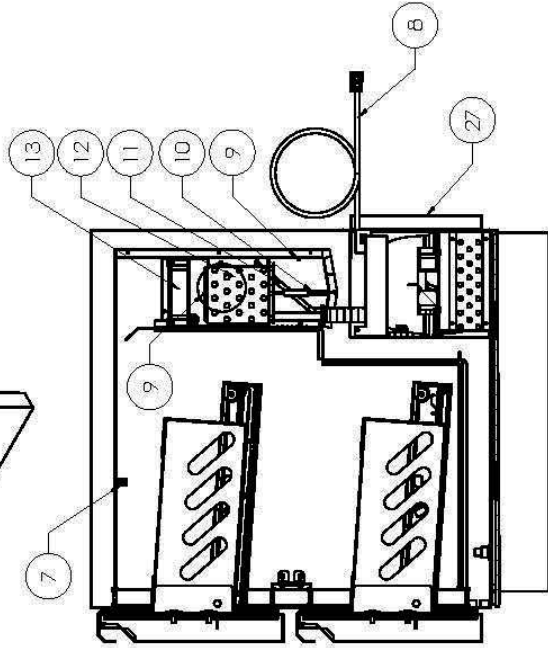
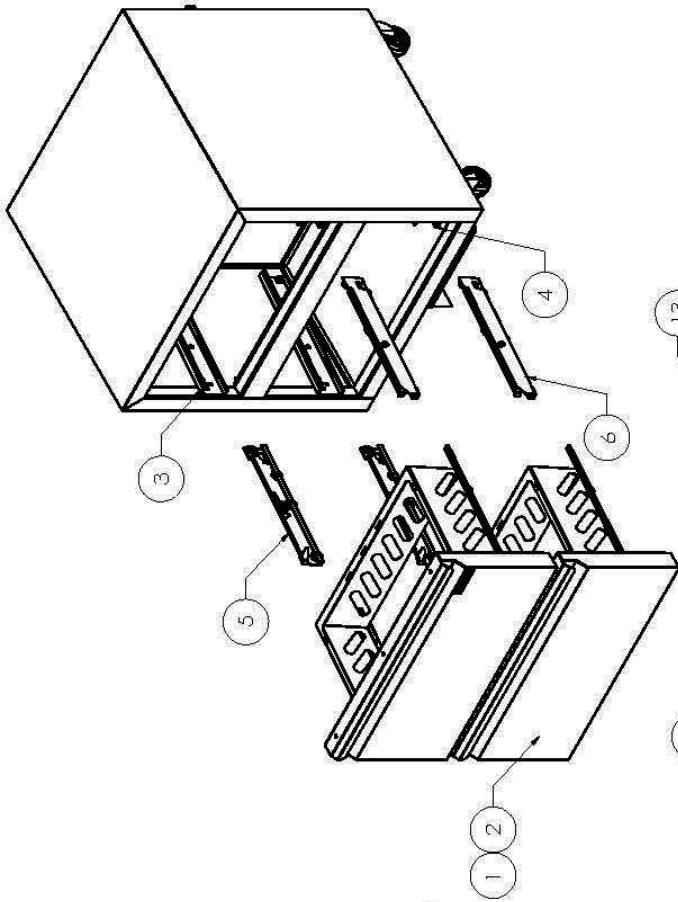

REPLACEMENT PARTS LIST - DEFF-27D2

ITEM NO.	PART DESCRIPTION	PART NO.
1	DRAWER ASSEMBLY COMPLETE	38327
2	DRAWER GASKET	10310-76
3	CABINET SLIDE LH	38315
4	CABINET SLIDE RH	38316
5	CENTER SLIDE LH	38317
6	CENTER SLIDE RH	38318
7	TEMPERATURE INDICATOR	22409
8	POWER CORD 115V	32199
9	DEFROST PROBE EVAPORATOR	38822
	TEMPERATURE PROBE	
10	DEFROST HEATER EVAPORATOR 115V	38344
11	CAPILLARY TUBE EVAPORATOR	22950
12	EVAPORATOR COIL	38337
13	EVAPORATOR FAN MOTOR 115V/60HZ	37736
14	AIR CURTAIN	38353
15	FILTER CONDENSER (OPTIONAL)	31221
16	CASTER KIT 2"	10314-100
	CASTER KIT 3"	10314-63
17	KIT COMPRESSOR W/ ELECTRICALS 115V/60HZ	10343-100
18	ELECTRICAL KIT 115V (RELAY, OVERLOAD, RUN CAPACITOR)	10344-100
19	GROMMET COMPRESSOR MOUNT	20481
20	WASHER COMPRESSOR MOUNT	22401
21	HAIRPIN CLIP	98106
22	DRIER	22677
23	ELECTRONIC TEMPERATURE CONTROL 115V	38553
24	CONDENSATE PAN ASSEMBLY	38379
25	CONDENSER FAN MOTOR 115V	37736
26	CONDENSER COIL	43339
27	REAR PANEL	39374

FORM 38253

WHEN ORDERING REPLACEMENT PARTS, PLEASE PROVIDE MODEL AND SERIAL NUMBERS.

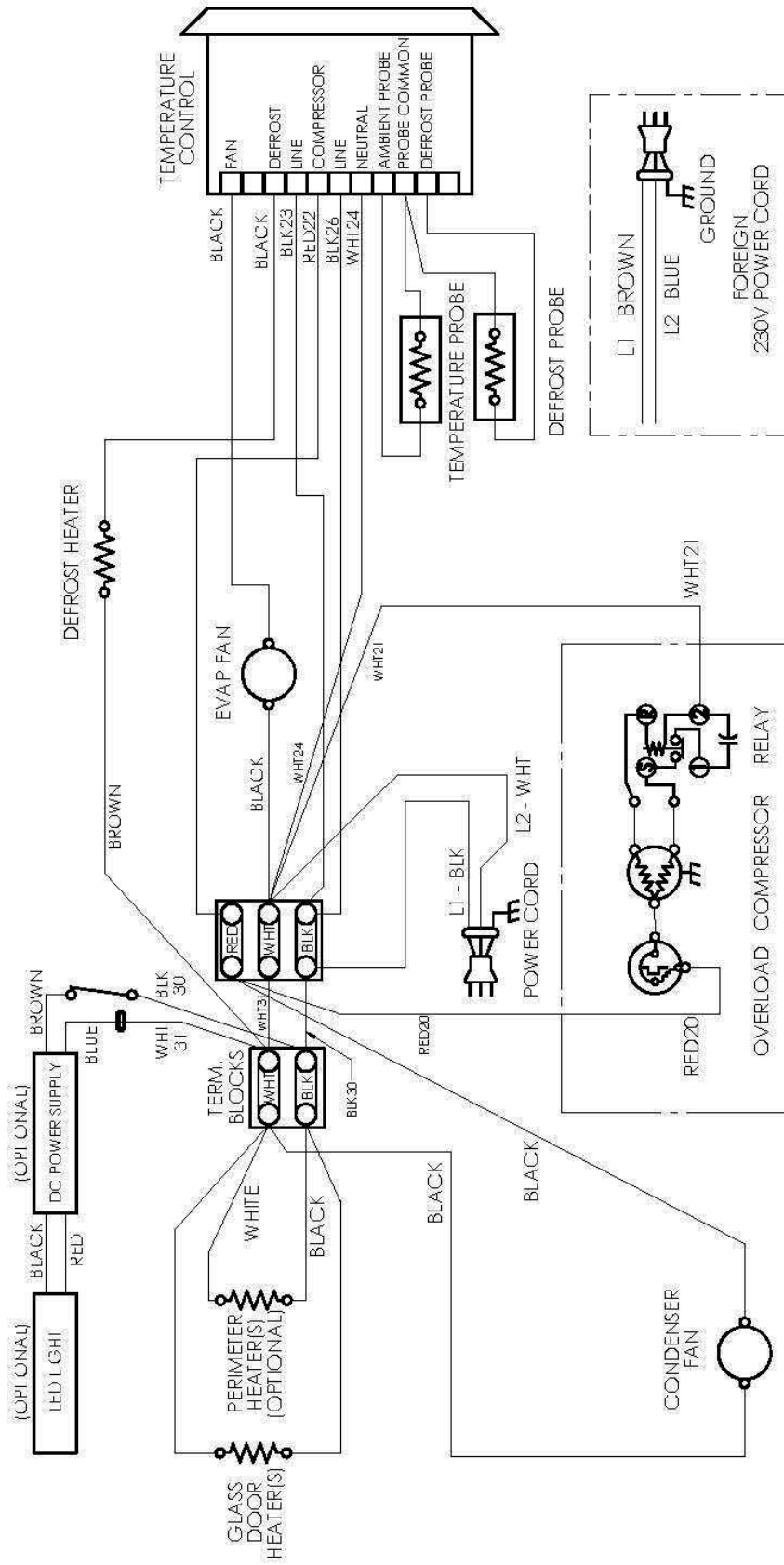

WIRING DIAGRAM
38500 REV B

SILVER KING LIMITED WARRANTY

Silver King Refrigeration warrants to the original purchaser of Silver King refrigerated equipment that the equipment shall be free from defects in material and workmanship under normal use and service as outlined in the Technical Manual. This limited warranty shall apply for a period of one (1) year from the date of original purchase. The Compressor will carry an additional four (4) year warranty. The warranty registration card attached must be filled out and returned within 10 days of installation or the warranty will be void. All warranties are subject to specific limitations outlined below.

This limited warranty does not apply to repair or replacement required as a result of carelessness, neglect and/or abuse, including improper installation, incorrect voltage supply, tampering with or altering components and/or equipment or failure to perform proper maintenance. Equipment damaged in transit, by fire, flood or an act of God is not covered. This limited warranty does not include freight, handling, installation, labor (following the one (1) year labor warranty period) or other incidental or consequential costs including product and/or economic loss. This limited warranty is in lieu of all other warranties, express or implied, including those of merchantability, and is non-transferable.

Specific provisions of this limited warranty are as follows:

One (1) Year Parts Warranty

Silver King warrants to the original purchaser of new Silver King equipment that such equipment and all parts thereof will be free of defects in material and workmanship, under normal use and service, for a period of one (1) year from the date of original purchase or 18 months from the date of shipment from the factory, whichever comes first, subject to all terms and conditions herein.

This warranty is limited to repairing or replacing any parts that, at Silver King's discretion, are deemed to be defective within the time period covered by this warranty. The one year parts warranty covers reasonable freight and handling charges. It does not cover special handling charges or expedited means for transport. Use of non-OEM parts may, at Silver King's discretion, void this warranty. If approved, warranty credit for non-OEM parts will be issued at the OEM cost.

Replacement parts sold separately are warranted for 90-days from date of purchase.

Five (5) Year Compressor Warranty

Silver King warrants to the original purchaser for a period of five (5) years from the date of original purchase or five (5) years and six (6) months from the date of shipment from the factory, whichever comes first, that it will replace the compressor with one of similar design and capacity, exclusive of delivery and installation charges, if it is found to Silver King's satisfaction to be inefficient or inoperative due to defects in material or factory workmanship. It is the owner's responsibility to return the serial plate of the defective compressor, or at Silver King's option the complete compressor, to the factory. Failure to do so will void the warranty.

Five (5) Year Heavy Duty Drawer Slide Warranty

Silver King warrants to the original purchaser for a period of five (5) years from the date of original purchase or five (5) years and six (6) months from the date of shipment from the factory, whichever comes first, that it will replace the heavy duty drawer slides with one of similar design and capacity, exclusive of delivery and installation charges, if it is found to Silver King's satisfaction to be inefficient or inoperative due to defects in material or factory workmanship.

One (1) Year Labor Warranty

Silver King warrants to the original purchaser for a period of one (1) year from the date of purchase or 18 months from the date of shipment from the factory, whichever comes first, a limited service labor warranty on Silver King refrigerated equipment subject to the following terms;

A factory issued Service Authorization Number must be obtained prior to work being performed under the labor warranty. Call your supplier or Silver King. Claims submitted without a Service Authorization Number will be paid at Silver King's discretion.

The labor warranty includes standard straight time labor charges in accordance with Silver King's Labor Warranty Guidelines and reasonable travel time, as determined by Silver King.

The warranty does not cover original installation, startup, normal adjustments or maintenance. Normal adjustments and maintenance include, but are not limited to; temperature control adjustments, temperature indicator calibrations, coil and filter cleaning, condensate drain cleaning.

A second service call for a related failure is not covered.

Use of refrigerants other than specified on the equipment serial plate voids the warranty.

All claims must include; model and serial number of equipment, date of purchase, date of failure, and a copy of the service invoice detailing the defect and service performed. No claim will be processed without this information. All claims must be filed within 60 days from date of service.