

Technical Manual and Replacement Parts List

FREEZER

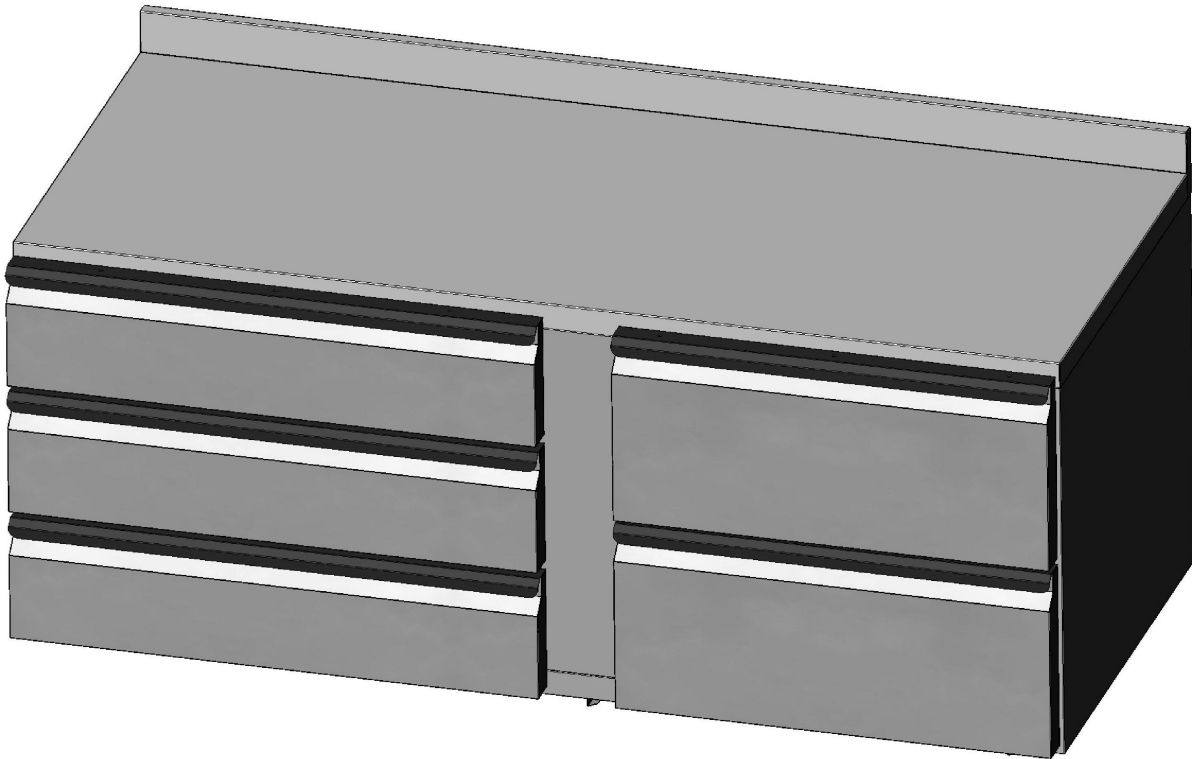

MODEL SKF72D

SILVER KING REFRIGERATION INC.

1600 Xenium Lane North, Minneapolis, MN 55441-3787
Phone (763) 923-2441

SILVER KING®

Specifications Subject to Change Without Notice.



TECHNICAL MANUAL
SILVER KING FREEZER
MODEL SKF72D

Thank you for purchasing Silver King food service equipment. Our goal is to provide our customers with the most reliable equipment in the industry today. Please read this manual and the accompanying warranty information before operating your new Silver King unit. Be sure to complete and mail the warranty card within 10 days of purchase to validate your warranty.

INSPECT FOR DAMAGE AND UNCRATE

Upon delivery of your new Silver King unit, uncrate at once to inspect for possible freight damage following the instructions printed on the exterior of the container. Report any damages to the carrier responsible for transportation and promptly present a claim for any evidence of mishandling. Save all packaging materials if a claim is filed.

INSTALLATION

The stainless steel exterior of the cabinet has been protected by a plastic covering during manufacturing and shipping. This covering can be readily stripped before installation. After removing this covering, wash the interior and exterior surfaces using a warm, mild soapy water solution and a sponge or cloth, rinse with clean water and dry.

Casters

The unit comes with four casters. To install them, tip the unit on its back (remove the drawers first to lighten the unit) and locate the four hex-screw patterns on the base of the unit. These hex screws are used to mount the plate casters. Remove the hex screws, align a plate caster over the four hole pattern and re-install the hex screws tightly to mount the casters. The casters with brakes should be installed at the front of the cabinet.

Condenser Filter Screen

The Condenser Filter Screen, Screen Pull and Filter Guides are packaged inside the unit. The instructions for installing these parts are included in this technical manual. Do not operate the unit without the filter screen installed!

Drawers

To remove drawers for cleaning, simply open them fully, lift up on the front of drawer, and pull drawer out. Replace drawers in the same fashion.

With drawer removed, the roller members can be removed by rocking the top of the roller member out when the roller member is pushed all the way to the back of the cabinet.

The drawer system is rated for a maximum dynamic load of 275 pounds. The drawers are not designed or intended as a surface to stand on. At no time should the drawers be extended and used as a platform for standing on to reach elevated equipment.

Location

When locating your new freezer, convenience and accessibility are important considerations, but the following installation guidelines must be followed;

*Always avoid placing the freezer adjacent to an oven, heating element or hot air source that would affect the operation of the unit.

*For proper ventilation the bottom front of the unit must not be obstructed. The unit must be on legs or casters to raise it off the floor. The unit can be installed tight on the sides and back.

*The unit must be level or tilted backwards slightly.

Electrical Connections

Be sure to check the data plate, located on the liner of the cabinet, for required voltage prior to connecting the unit to power. The specifications on the data plate supersede any future discussion.

The standard freezer is equipped with an eight (8) foot power cord that requires a 115 Volt, 60 Cycle, 1 Phase **properly grounded** electrical receptacle. The power cord comes with a 3 prong plug for grounding purposes. Any attempt to cut off the grounding spike or to connect to an ungrounded adapter plug will void the warranty, terminate the manufacturers responsibility and could result in serious injury.

The circuit must be protected with a 15 or 20 ampere fuse or breaker. The unit must be isolated on a circuit and not plugged into an extension cord.

OPERATION

Initial start up

After satisfying the installation requirements, the freezer is ready to start. The Compressor will start when the power cord is connected to the required power source. If the Compressor does not start when the unit is initially plugged in, check to make sure that the Temperature Control is not in the "off" position. Allow the unit to run for two hours before loading it with product. When loading the unit with product, take care not to block the air flow in the cabinet as this would affect the units performance.

Temperature Control

The Temperature Control is located on the front of the evap panel and is factory set to maintain an average cabinet temperature of -5 to 5 Deg. F. Temperature may rise with prolonged drawer opening or following a defrost cycle.

Defrost

Your Silver King freezer is an automatic defrost unit and no additional plumbing is required. Defrost water is collected in a pan located in the compressor compartment where it is evaporated into the room air. It is important that the unit be installed level to allow proper drainage of the defrost water.

MAINTENANCE

Preventative maintenance is minimal although these few steps are very important to continued operation and maximizing the life of the appliance.

Cabinet Surfaces

The cabinet interior is aluminum and stainless steel and the exterior is stainless steel. These surfaces should be cleaned periodically with a solution of warm water and mild soap, rinsed and wiped dry with a soft cloth. A good stainless steel cleaner can also be used. Should a surface become stained, do not attempt to clean with an abrasive cleanser or scouring pad. Use a soft cleanser and rub with the grain of the metal to avoid scratching the surface. Do not use chlorinated cleaners. Always rinse well and dry after cleaning.

Condenser

Periodically the Condenser Filter Screen must be cleaned. The Condenser Filter Screen is located on the bottom of the cabinet. To clean it simply pull it out the front of the unit using the Filter Screen Pull and rinse it in a stream of water. Dry the screen by tapping it on a counter or floor. Replace the filter screen by placing it into the filter screen tracks on the bottom of the unit and sliding it all the way to the rear of the cabinet. Do not operate the unit without the filter sreen installed!

Drawer Gasket

The Door Gasket will collect dirt and should be wiped clean with a warm, mild soapy water solution to extend its life and assure maximum cabinet performance and life.

MODEL _____ SERIAL NO. _____ DATE INSTALLED _____

FILTER GUIDES AND SCREEN INSTALLATION INSTRUCTIONS

MODELS: SKF48, SKP7218, SKP7230, SKPZ60, SKPZ92, SKR48, SKP488, SKP4812, SKP4818

DO NOT OPERATE UNIT WITHOUT FILTER SCREEN AND AIR CURTAIN INSTALLED

1. Disconnect unit from power source.
2. Tip the unit on its back and loosen the 2 screws along the top edge of the base.
3. Insert tab on the end of the filter guide with curtain into the slot located along the lower edge of the base unit.
4. Slip the opposite end of the filter guide with curtain under the screw head loosened in step 2, pull forward, and tighten screw to secure the filter guide to base.
5. Repeat step 4 with right filter guide.
6. Insert filter screen into tracks formed by the guides and slide back until the screen stops.
7. Install legs or casters.
8. Return unit to original upright position.

This kit includes:

- Filter guide with curtain
- Right filter guide
- Filter screen

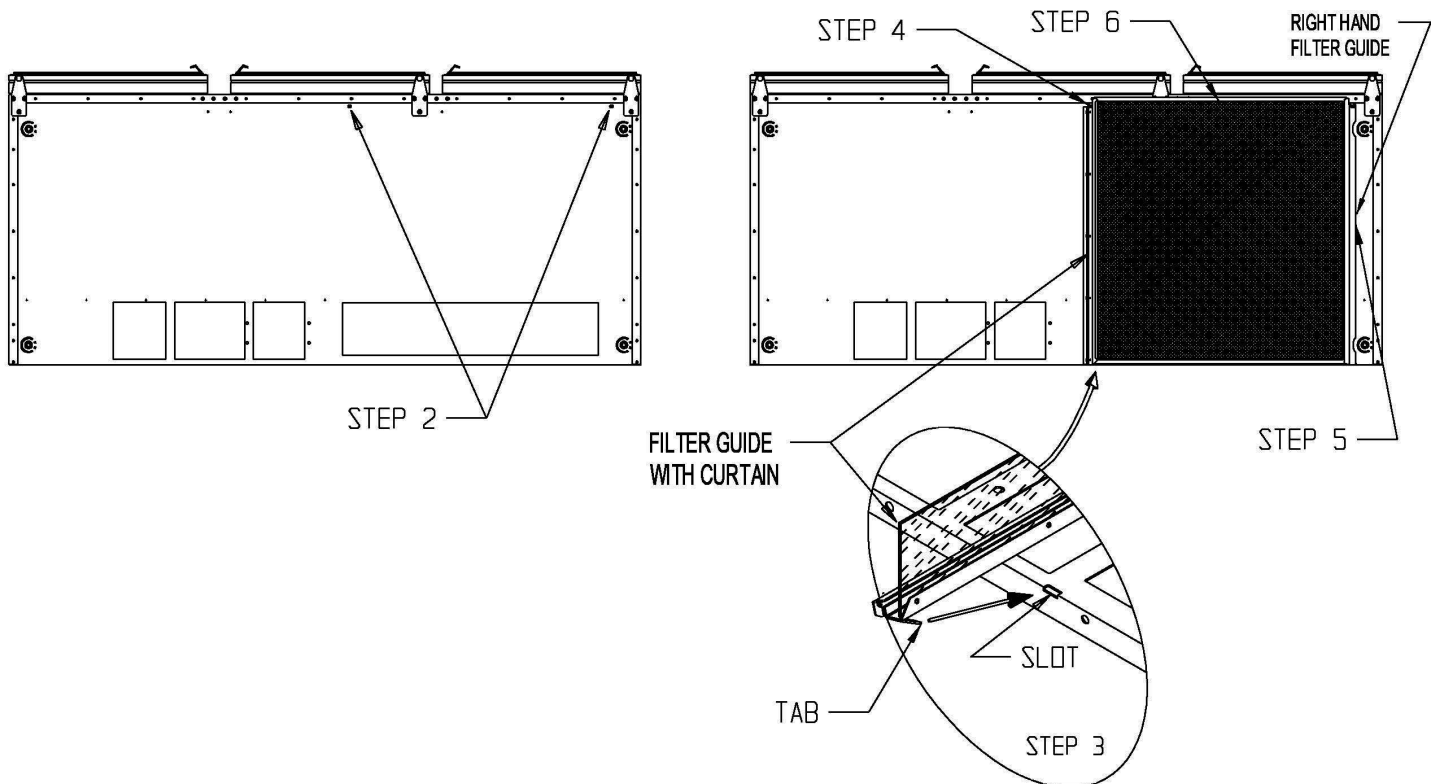

REPLACEMENT PARTS LIST – MODEL F72D

ITEM NO.	PART DESCRIPTION	PART NO.
1	TEMPERATURE CONTROL	42575
2	PLATE, TEMPERATURE CONTROL	20653
3	KNOB, TEMPERATURE CONTROL	21487
4	TEMPERATURE INDICATOR	22409
5	SCREW	97007
6	FILTER SCREEN	31225
7	KIT FILTER W/ GUIDES	27263-6
8	REAR PANEL	24892
9	CONDENSER COIL	24801
10	CONDENSER FAN BLADE, 6.75"	24194
11	CONDENSER FAN MOTOR, 115V	22048
12	POWER CORD, 115V	42667
13	DEFROST HEATER, 115V	34950
14	HEAT EXCHANGER 115V	35507
15	EVAPORATOR COIL	35311
16	DEFROST THERMOSTAT	33338
17	EVAPORATOR FAN MOTOR, 115V/60HZ	21256
18	EVAPORATOR FAN BLADE, 5"	99196
19	FAN GUARD	41473
20	CASTER KIT, 4"	10314-78
21	WMENT PLATE SLIDE	28821
21	WMENT PLATE SLIDE LARGE	35303
22	DRAWER ASSEMBLY LARGE	35014
23	DRAWER GASKET LARGE	34826
24	SLIDE 22 IN CENTER MEMBER RH	28824
25	SLIDE 22 IN CENTER MEMBER LH	28825
26	CONDENSATE PAN	24966
27	DEFROST TIMER, 115V	99291
28	ELECTRICAL KIT, 115V (RELAY, OVERLOAD, CAPACITOR)	10344-65
29	COMPRESSOR KIT W/ ELECTRICALS, 115V/60HZ	10343-65
30	DRIER	23793
31	GROMMET, COMPRESSOR MOUNT	20481
32	HAIRPIN CLIP	98106
33	DRAWER ASSEMBLY SMALL	34919
34	DRAWER GASKET SMALL	34740

WHEN ORDERING REPLACEMENT PARTS, PLEASE PROVIDE MODEL AND SERIAL NUMBERS

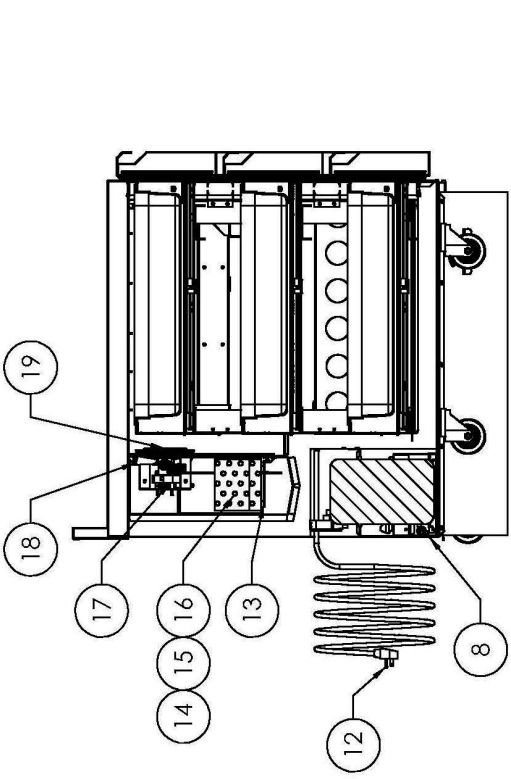
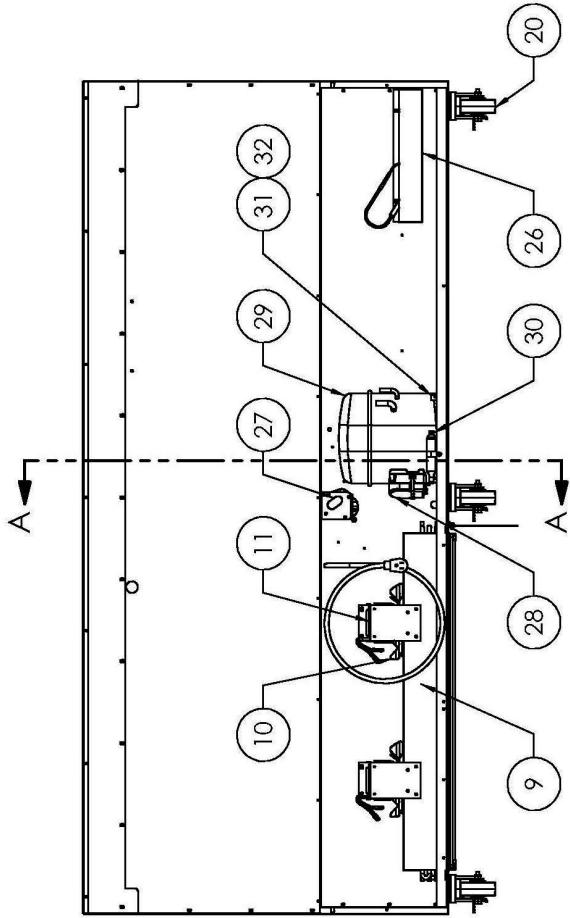

SECTION A-A

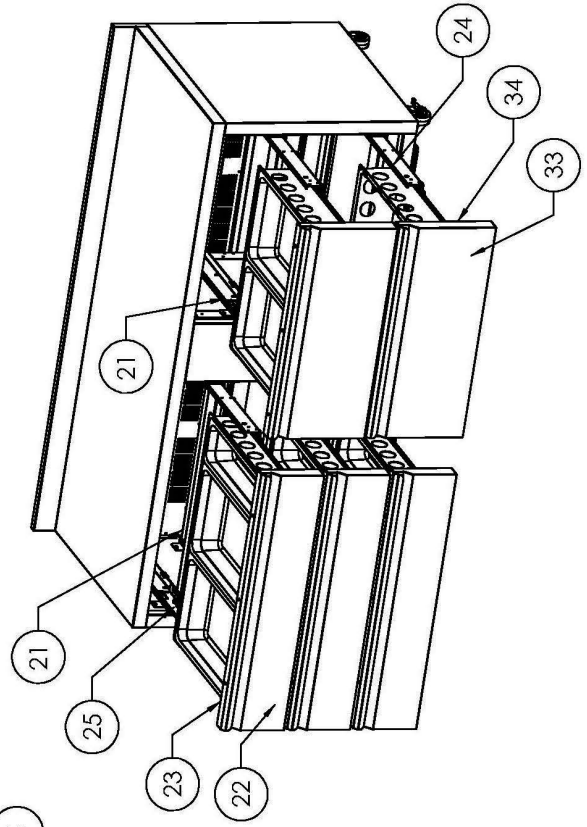
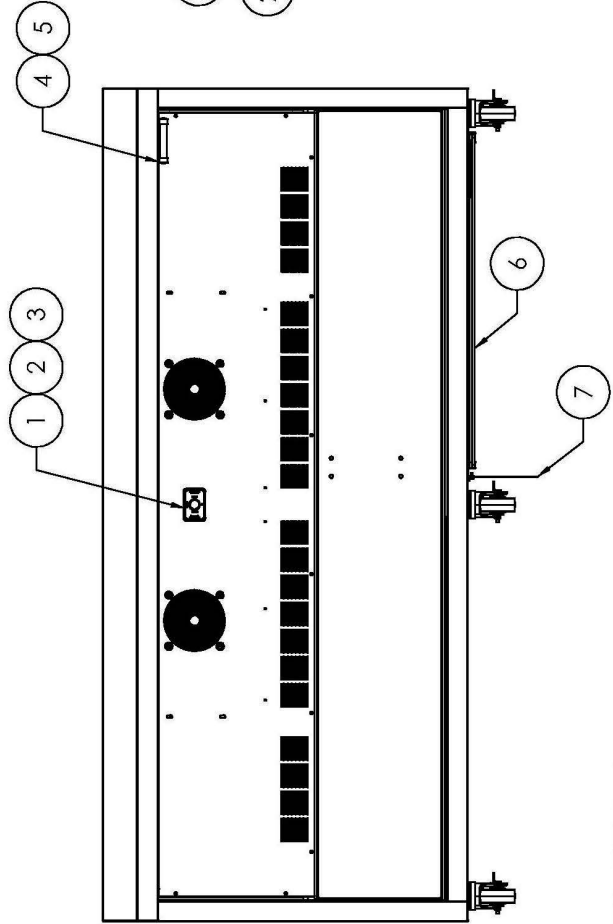

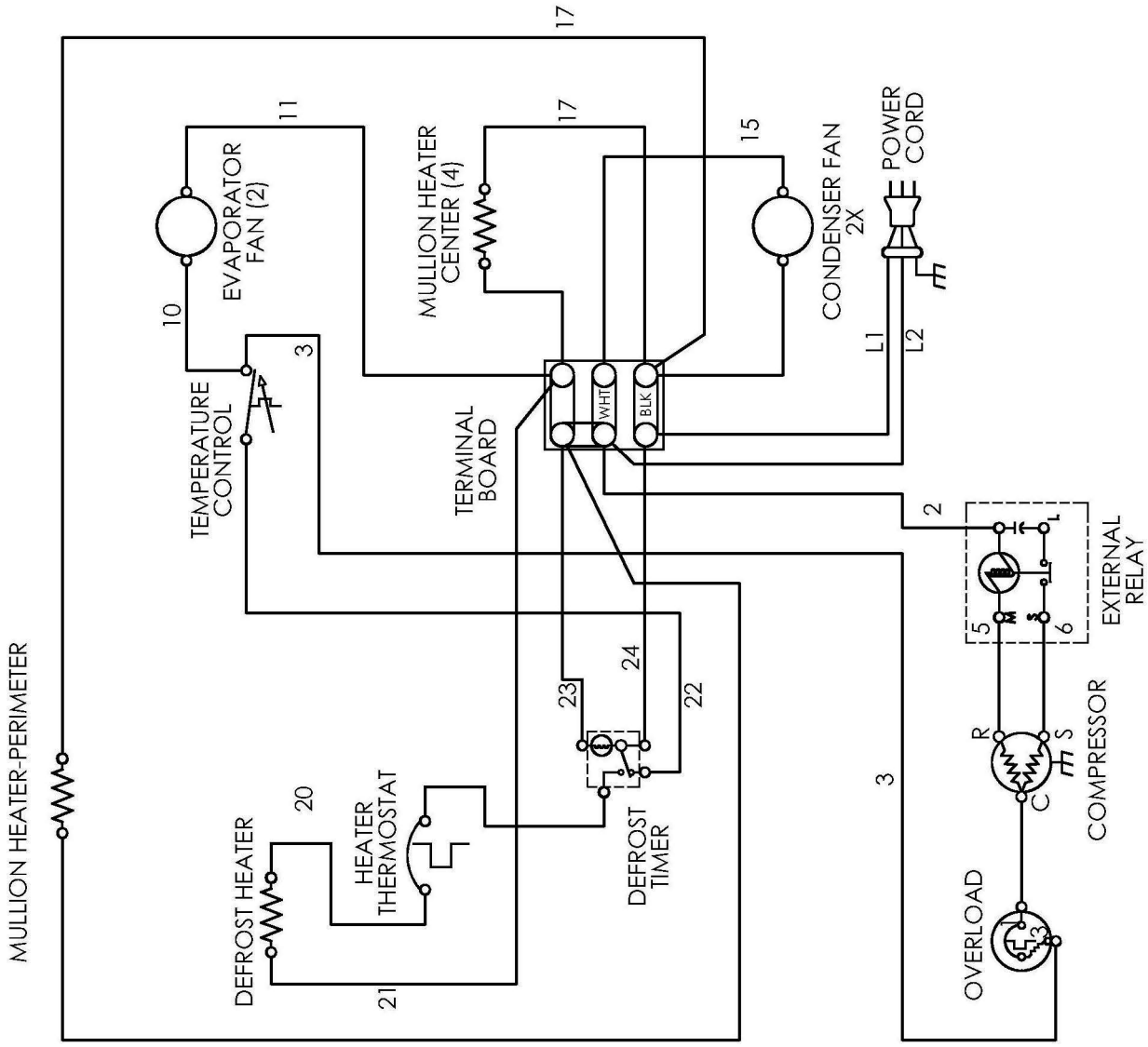

35509 REV. A

Silver King Tech Bulletin

Bulletin Number: 4

Date: 11/4/14

Subject: SKF72 Freezing Issues

Older model SKF72 freezers have had issues with the evaporator freezing solid due to insufficient amount of defrosts per day and also with the defrost heaters not in direct contact with the evaporator controls. Tech bulletin 4 addresses these issues.

Upon arriving on Site inspect to see if the unit is iced up, and not reaching set point of 0 degrees, if so, follow these steps in order to correct the problem.

- Inspect Defrost heater
- Install New Defrost Timer
- Install new defrost thermostat

Inspect Defrost heater to insure it is tightly affixed to the bottom evaporator coil.

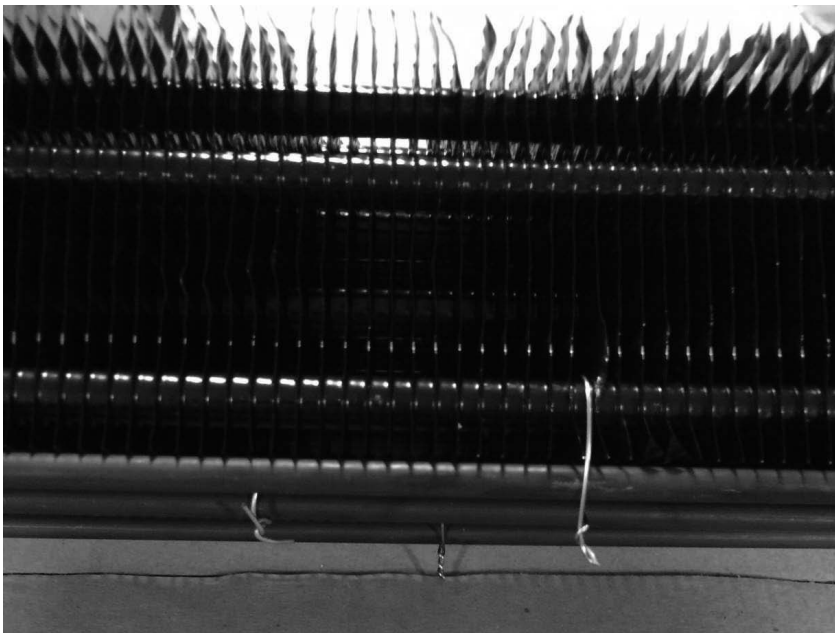

If not tight, use stainless wire to hold heater rod tight to the bottom of the evaporator.

Install new defrost timer

(4 hour interval, 21 minute duration, 6 cycles per day)

New timer 38693

Terminal 1	L1	(normally black wire)
Terminal 2	Defrost thermostat	(normally brown wire)
Terminal 3	Neutral	(normally white wire)
Terminal 4	Temperature control	(normally red wire)

Old timer 99291:

Terminal 1	Defrost thermostat	(normally brown wire)
Terminal 2	L1	(normally black wire)
Terminal 3	Neutral	(normally white wire)
Terminal 4	Temperature control	(normally red wire)

Install New Defrost thermostat

- Remove old defrost thermostat Part number 33338
- Install new defrost thermostat Part Number 38801
- Install at uppermost middle tube bend on the evaporator
- Make sure part of the heater sits in the drain pan to help keep the drain defrosted

