

Technical Manual and Replacement Parts List

Freezer Chef Base

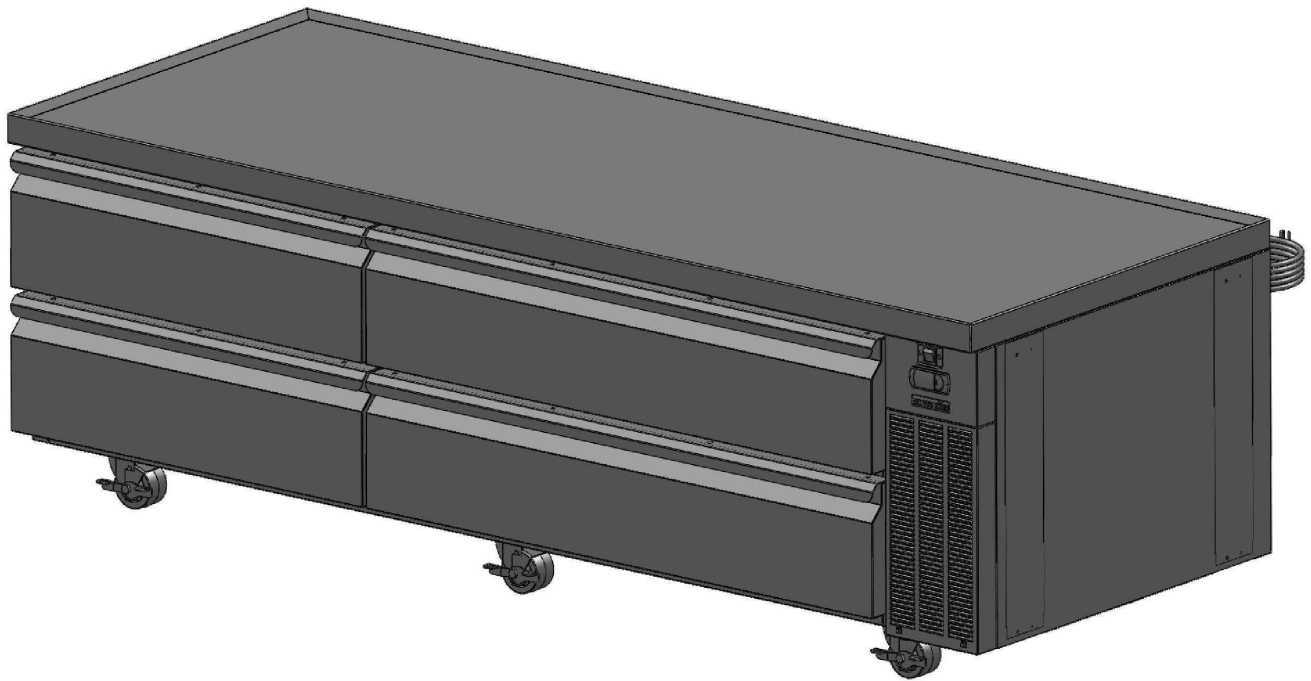

MODEL SKFCB79H (SHOWN)
SKFCB84H

SILVER KING REFRIGERATION INC.

1600 Xenium Lane North, Minneapolis, MN 55441-3787
Phone (763) 923-2441



FORM NO. 37811 REV A

Specifications Subject to Change Without Notice.



TECHNICAL MANUAL
SILVER KING FREEZER CHEF BASES
MODELS SKFCB79H AND SKFCB84H

Thank you for purchasing Silver King food service equipment. Our goal is to provide our customers with the most reliable equipment in the industry today. Please read this manual and the accompanying warranty information before operating your new Silver King unit. Be sure to complete and mail the warranty card within 10 days of purchase to validate your warranty.

INSPECT FOR DAMAGE AND UNCRATE

Upon delivery of your new Silver King unit, uncrate at once to examine and test for possible damage following the instructions printed on the exterior of the container. Report any damages to the carrier responsible for transportation and promptly present a claim for any evidence of mishandling. Save all packaging materials if a claim must be filed.

INSTALLATION

The stainless steel exterior of the cabinet has been protected by a plastic covering during manufacturing and shipping. This covering can be readily stripped before installation. After removing this covering, wash the interior and exterior surfaces using a warm, mild soapy water solution and a sponge or soft cloth. Rinse afterward with clean water and wipe dry. Do not use chlorinated cleaners.

Location

When locating your new Silver King unit, convenience and accessibility are important considerations, but the following installation guidelines must be observed;

- When stacking cooking equipment on these units observe the following load limits: Models SKRCB50H and SKRCB60H have a maximum load limit of 950 pounds of stacked equipment.
- Stacked cooking equipment should not transfer excessive heat down onto the cabinet. When cabinet surface temperatures exceed 150° F damage to cabinet insulation may occur.
- The unit must be level.
- Allow at least 2 inches of space on the right and back side, no space on the left side and leave the top open for proper air flow.
- All caster brakes should be set when the unit is positioned in its intended place.

Legs/Casters

The unit comes with legs or casters (four on models SKRCB50H and 60H). To install them, tip the unit on its back (remove the drawers first to lighten the unit) and locate the four hex-screw patterns on the base of the unit. These hex screws are used to mount the plate casters. Remove the hex screws, align a plate caster over the four hole pattern and re-install the hex screws tightly to mount the casters. The casters with brakes should be installed at the front of the cabinet.

Drawers

To remove drawers for cleaning, simply open them fully, lift up on the front of drawer, and pull drawer out. Replace drawers in the same fashion.

With drawer removed the roller members can be removed by rocking the top of the roller member out when the roller member is pushed all the way to the back of the cabinet.

The drawer system is rated for a maximum dynamic load of 275 pounds. The drawers are not designed or intended as a surface to stand on. At no time should the drawers be extended and used as a platform for standing on to reach elevated equipment.

Electrical Connections

Be sure to check the data plate, located on the liner of the cabinet, for required voltage prior to connecting the unit to a power source. The specifications on the data plate supersede any future discussion.

The standard unit is equipped with an eight (8) foot power cord that requires a 115 Volt, 60 Cycle, 1 Phase properly grounded electrical receptacle. The power cord comes with a 3 prong plug for grounding purposes. Any attempt to cut off the grounding spike or to connect to an ungrounded adapter plug will void the warranty, terminate the manufacturers responsibility and could result in serious injury.

The circuit must be protected with a 15 or 20 ampere fuse or breaker. The unit must be isolated on a circuit and not plugged into an extension cord.

OPERATION

Initial Start Up:

After satisfying the installation requirements, the unit is ready to start. The unit will start when the power cord is connected to the required power source. Allow the unit to run a minimum of two hours before loading it with product.

Temperature Control

The Electronic Temperature Control is located on the front of the unit. To check the temperature control set point, push and release the 'set' button on the control and the display will show the set point temperature. To adjust the set point, push and hold the 'set' button for two seconds then push the up or down arrows to adjust the set point. Either press the 'set' button again or wait 10 seconds and the control will store the new set point. Allow the unit a minimum of one hour to respond to a control setting adjustment.

Defrost

Your Silver King unit is an automatic defrost unit. No additional plumbing is required. Defrost water is collected in a pan located in the compressor compartment where it is evaporated into the room air. It is important that the unit be level so the condensate can drain properly. To initiate a defrost cycle push the bottom right button (melting snowflake) on the temperature control for two seconds.

MAINTENANCE

Preventative maintenance is minimal although these few steps are very important to continued operation and maximizing the life of the appliance.

Cabinet Surfaces

The cabinet interior is aluminum and the exterior is stainless steel. These surfaces should be cleaned periodically with a solution of warm water and mild soap. After cleaning the surfaces should be rinsed with clean water and wiped dry with a soft cloth. Stainless steel cleaners can be used on the exterior. Should a surface become stained, do not attempt to clean with an abrasive cleaner or scouring pad. Use a soft cleanser and rub with the grain of the metal to avoid scratching the surface. Always rinse well and dry after cleaning. Do not use chlorinated cleaners.

Condenser

Periodically, dust on the condenser coil must be cleaned. The condenser is located behind the front cover at the right front of the unit. Remove the front cover by pulling on the bottom edge of the cover. The condenser will be exposed. Clean the accumulated dust/debris from the condenser with a vacuum or brush. This will need to be done regularly to maintain the compressor warranty!

Casters

Check to make sure that the casters are installed tightly to the cabinet.

MODEL _____ SERIAL NO. _____ DATE INSTALLED _____

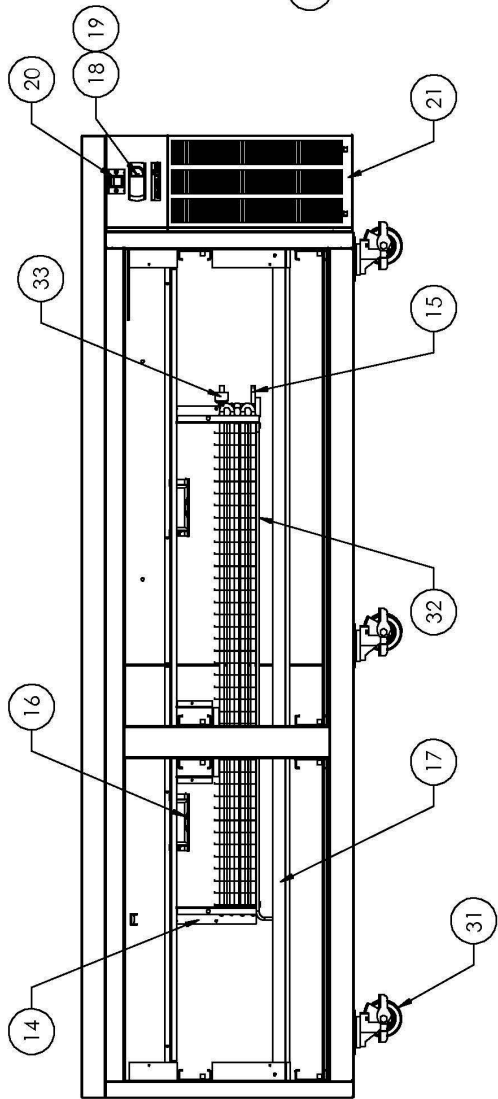
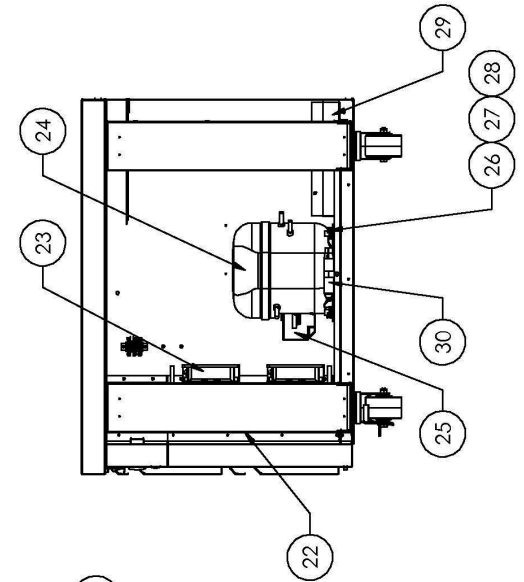
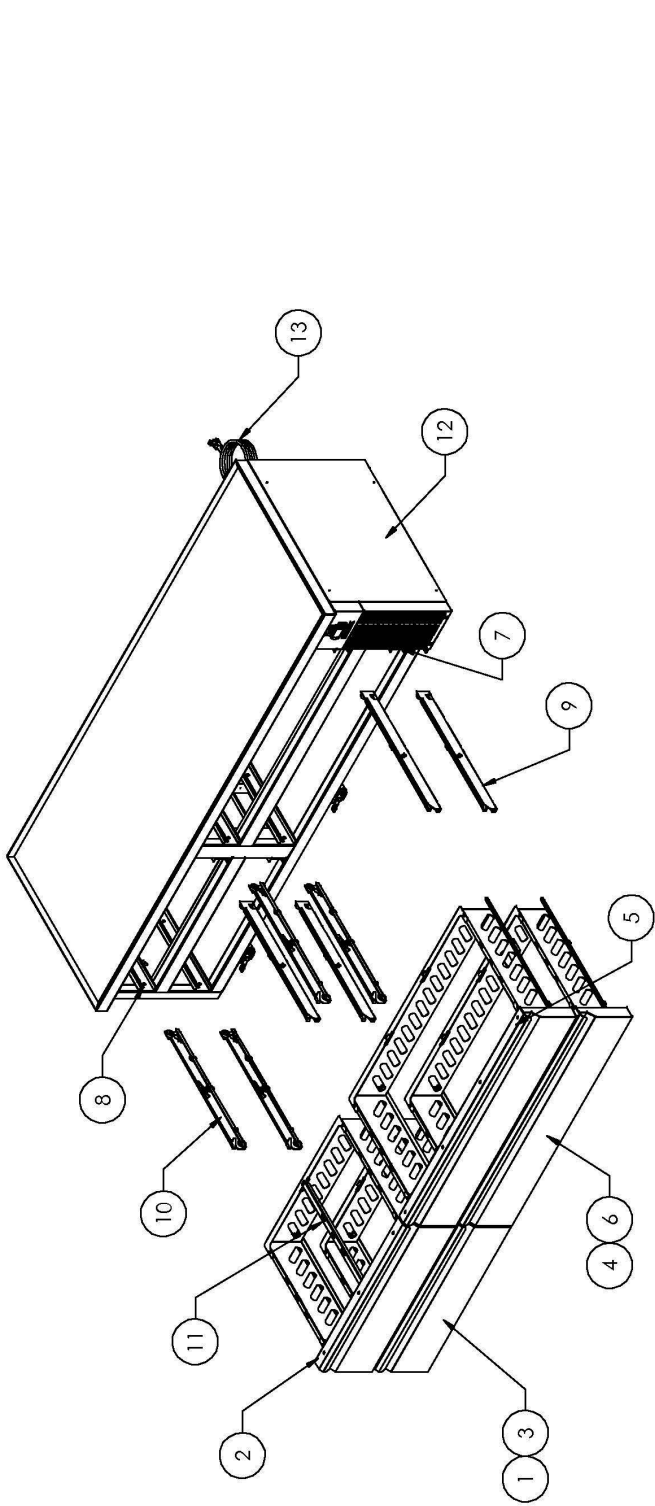

REPLACEMENT PARTS LIST - SKFCB79H/84H

ITEM NO.	PART DESCRIPTION	PART NO.
1	DRAWER ASSEMBLY COMPLETE (2 PAN DRAWER)	37785
2	DRAWER HANDLE (2 PAN DRAWER)	26188
3	DRAWER GASKET (2 PAN DRAWER)	10310-55
4	DRAWER ASSEMBLY COMPLETE (3 PAN DRAWER)	37784
5	DRAWER HANDLE (3 PAN DRAWER)	26025
6	DRAWER GASKET (3 PAN DRAWER)	10310-56
7	CABINET SLIDE MEMBER RH	34503
8	CABINET SLIDE MEMBER LH	34504
9	DRAWER SLIDE ROLLER MEMBER RH	34509
10	DRAWER SLIDE ROLLER MEMBER LH	34510
11	ADAPTER BAR	28726
12	RIGHT END PANEL	37664
13	POWER CORD 115V	32199
14	EVAPORATOR COIL	37716
15	HEAT EXCHANGER (CAP TUBE AND SUCTION LINE)	37806
16	FAN MOTOR 115V EVAPORATOR	37736
17	DRAIN PAN ASSEMBLY EVAPORATOR	37652
18	TEMPERATURE CONTROL ELECTRONIC	37586
19	TEMPERATURE PROBE	30660
20	POWER SWITCH	26378
21	FRONT COVER ASSEMBLY	37767
22	CONDENSER COIL	37737
23	FAN MOTOR 115V CONDENSER	37736
24	COMPRESSOR KIT 115/60 (INCLUDES ELECTRICALS AND DRIER)	10343-80
25	ELECTRICAL KIT 115/60	10344-80
26	GROMMET - COMPRESSOR MOUNT	20481
27	WASHER - COMPRESSOR MOUNT	22401
28	HAIRPIN CLIP - COMPRESSOR MOUNT	98106
29	CONDENSATE PAN ASSEMBLY	37768
30	DRIER	22677
31	CASTER KIT 4 INCH (SIX CASTERS)	10314-91
32	DEFROST HEATER 115V	37742
33	DEFROST LIMIT SWITCH	33338

FORM 37810

WHEN ORDERING REPLACEMENT PARTS, PLEASE PROVIDE MODEL AND SERIAL NUMBERS.

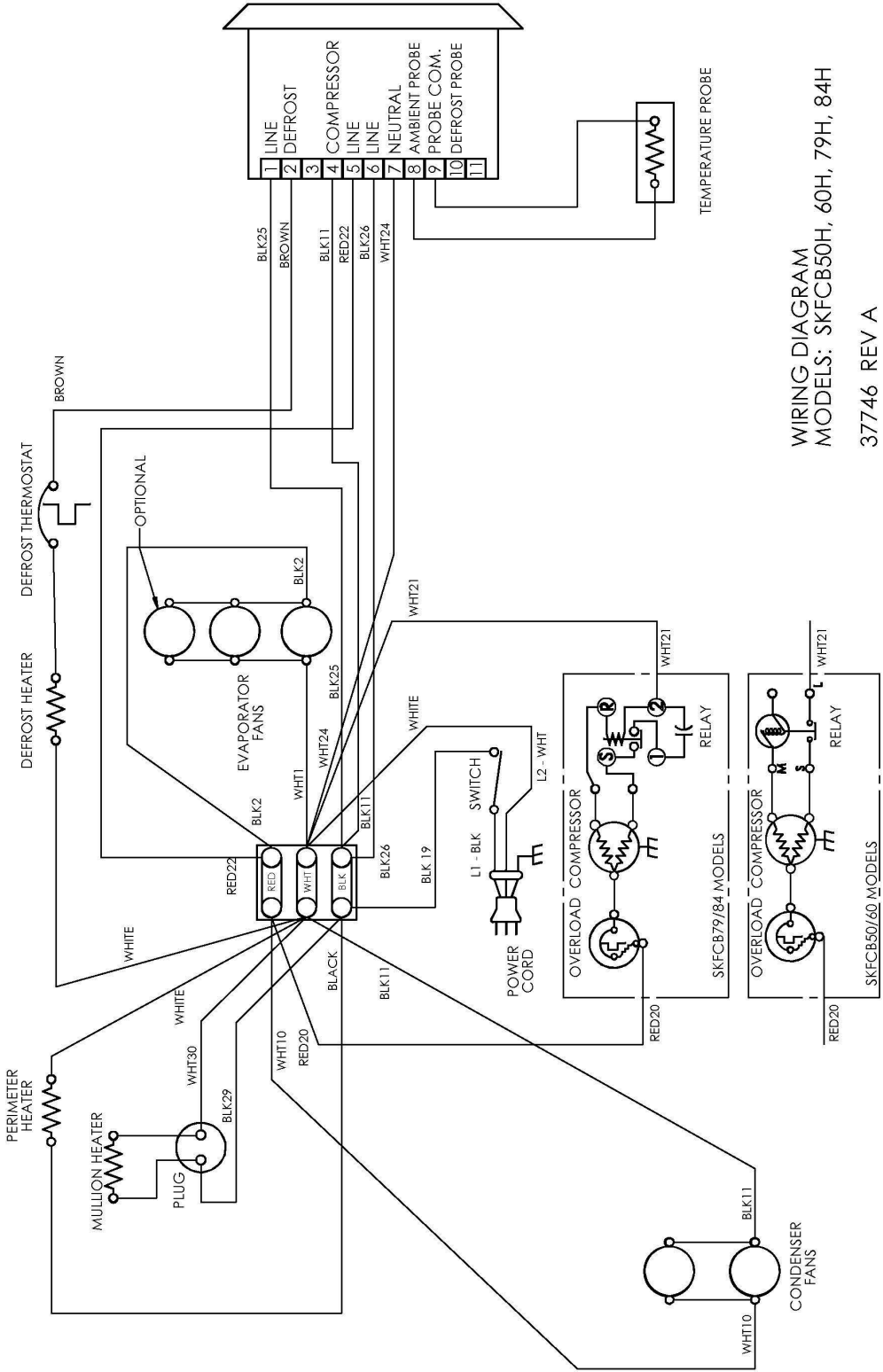

WIRING DIAGRAM
 MODELS: SKFCB50H, 60H, 79H, 84H
 37746 REV A