

# Technical Manual and Replacement Parts List

---

## Mobile Freezer



MODEL SKFS2

**SILVER KING REFRIGERATION INC.**

1600 Xenium Lane North, Minneapolis, MN 55441-3787  
Phone (763) 923-2441

**SILVER KING**<sup>®</sup>

Specifications Subject to Change Without Notice.



**TECHNICAL MANUAL**  
**SILVER KING MOBILE FREEZER**  
**MODELS SKFS2**

Thank you for purchasing Silver King food service equipment. Our goal is to provide our customers with the most reliable equipment in the industry today. Please read this manual and the accompanying warranty information before operating your new Silver King unit. Be sure to complete and mail the warranty card within 10 days of purchase to validate your warranty.

**UNCRATE AND INSPECT FOR DAMAGE**

Upon delivery of your new Silver King unit, uncrate at once to inspect for possible freight damage following the instructions printed on the exterior of the container. Report any damages to the carrier responsible for transportation and promptly present a written claim for any evidence of mishandling. Be sure to save all packaging materials if a claim is to be filed.

**INSTALLATION**

The stainless steel exterior of the cabinet has been protected by a plastic covering during manufacturing and shipping. The covering can be readily stripped from the unit before installation. After removing the covering, wash the interior and exterior surfaces using a warm, mild soapy water solution and a sponge or cloth, rinse with clean water and dry thoroughly.

**Casters**

To install the included casters, tilt the unit and thread the Legs or Casters into the four Rivnuts in the bottom of the cabinet. Make sure that they are installed tightly to prevent future thread wear.

**Location**

When locating the freezer, convenience and accessibility are important considerations, but the following factors must be observed:

- The unit must be level.
- Allow at least 6 inches of space at both ends to allow for proper air flow through the louvered panels. The space above the unit should be open to allow access to the product.
- Avoid placing the freezer next to ovens, heating elements or hot air sources that would affect the performance of the unit.

**Electrical Considerations**

Be sure to check the data plate, located on the liner of the cabinet, for required voltage prior to connecting the unit to power. The specifications on the data plate supersede any future discussion.

The standard freezer is equipped with an eight (8) foot power cord that requires a 115 Volt, 60 Cycle, 1 Phase properly grounded electrical receptacle. The power cord comes with a 3 prong plug for grounding purposes. Any attempt to cut off the grounding spike or to connect to an ungrounded adapter plug will void the warranty, terminate the manufactures responsibility and could result in serious injury.

The circuit must be protected with a 15 or 20 amp fuse or breaker. The use of extension cords is not recommended with this unit.

## **OPERATION**

### **Initial Start Up**

After satisfying the installation requirements, the freezer is ready to operate. The unit will start when the power cord is connected to a live electrical receptacle. If the Compressor and Condenser Fan are not running when the unit is initially connected to power, check to make sure that the Temperature Control is not set to the 'off' position. Allow the unit to run a minimum of two (2) hours before loading it with product.

### **Temperature Control**

The Temperature Control, located behind the service panel in the rear of the cabinet, comes set at the midpoint position, #4, which will maintain an average cabinet temperature of about 0 Deg F. To obtain cooler temperatures turn the Temperature Control clockwise and vice versa. Allow the unit a minimum of six hours to fully respond to a control setting adjustment if the product is in the cabinet.

### **Defrost**

This freezer is a manual defrost unit. The unit should be defrosted whenever the walls accumulate a frost bank that is 1/2 inch thick. To defrost the unit, first remove the product and the covers from the unit then either turn the Temperature Control to the 'off' position or disconnect the power cord from the electrical receptacle. After the frost has melted or come loose from the cabinet walls, wipe out the cabinet interior with a sponge or position the unit over a floor drain and remove the drain plug allowing the condensate to drain out of the cabinet and into the floor drain. Do not attempt to scrape or chisel off the frost as you could do irreparable damage to the cabinet.

## **MAINTENANCE**

Preventative maintenance is minimal although these few steps are very important to continued operation and maximizing the life of the appliance.

### **Cabinet Surfaces**

The interior and exterior surfaces are stainless steel and should be cleaned periodically with a solution of warm water and a mild soap, rinsed with clean water and wiped dry. A good stainless steel cleaner can also be used. Should a surface become stained or discolored, do not attempt to clean with an abrasive cleaner or scouring pad. Use a soft cleaner and rub with the grain of the metal to avoid scratching the surface. Always rinse and dry afterwards. Do not use chlorinated cleaners on the stainless steel.

### **Condenser**

Periodically, dust accumulated on the Condenser should be removed. First, disconnect the unit from the power supply. Remove the service panel to expose the Condenser. Remove the accumulated dust by vacuuming or blowing air through the coil. This procedure will save on Compressor running time (electrical costs) and also extend the life of the Compressor.

### **Casters**

Retighten the Casters to the base of the unit regularly to prevent damage to the base of the cabinet.

MODEL \_\_\_\_\_ SERIAL NO. \_\_\_\_\_ DATE INSTALLED \_\_\_\_\_

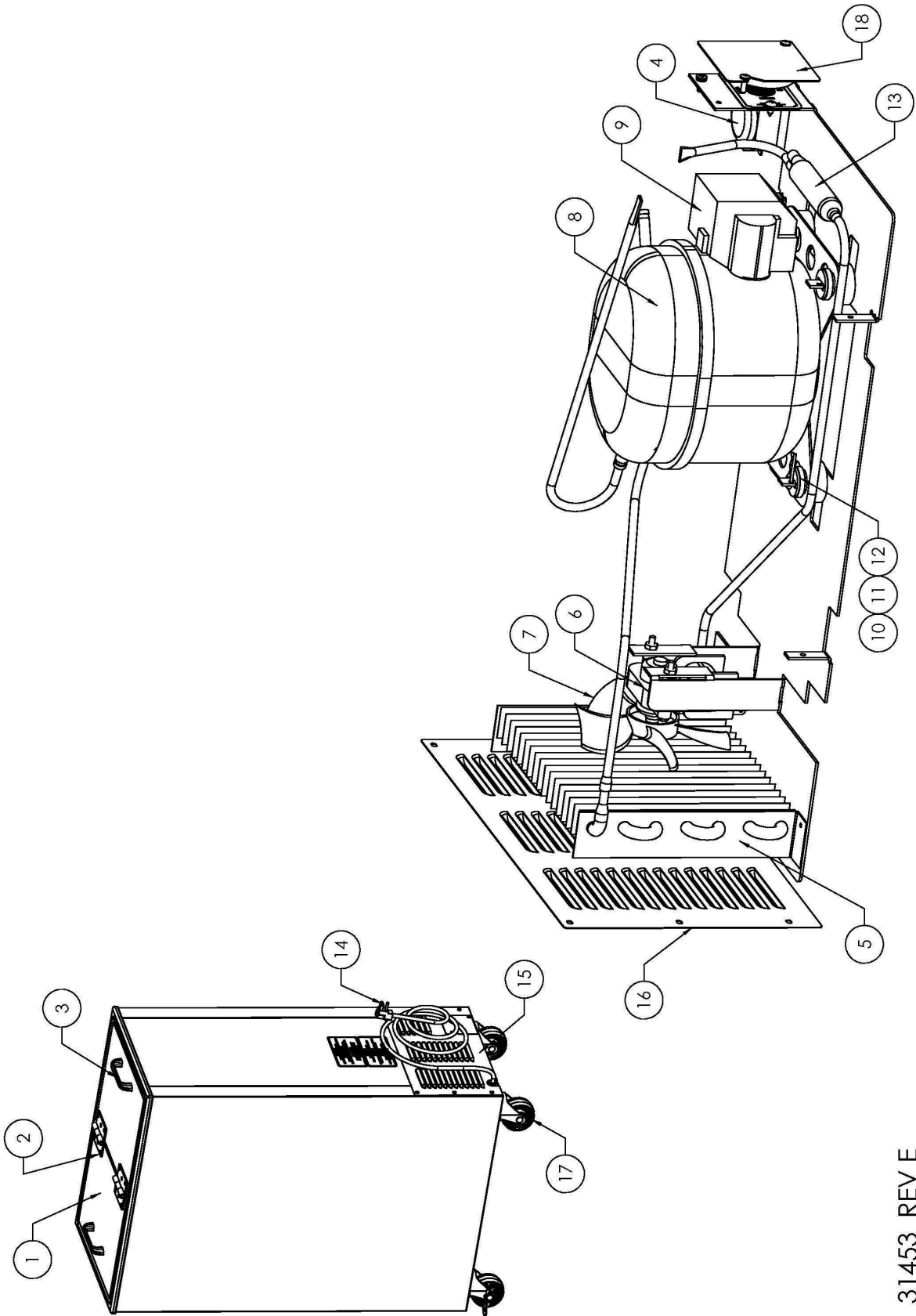

31453 REV E

# REPLACEMENT PARTS LIST - SKFS2

ITEM NO.	PART DESCRIPTION	PART NO.
1	DOOR ASSEMBLY WITH HANDLES AND HINGES	31242
2	DOOR HINGE	34519
3	DOOR HANDLE	28788
4	TEMPERATURE CONTROL	21332
5	CONDENSER COIL	43647
6	CONDENSER FAN MOTOR	21251-2
7	CONDENSER FAN BLADE	22943
8	COMPRESSOR KIT, 115V	10343-02
9	COMPRESSOR ELECTRICAL KIT, 115V	10344-02
10	COMPRESSOR GROMMET	20481
11	COMPRESSOR HAIRPIN CLIP	98106
12	COMPRESSOR MOUNTING WASHER	22401
13	DRIER	23793
14	POWER CORD, 115V	43263
15	BACK PANEL	32808
16	FRONT PANEL	32809
17	CASTER KIT, 3"	10314-63
18	ACCESS CONTROL COVER	31685

FORM 31453

WHEN ORDERING REPLACEMENT PARTS, PLEASE PROVIDE MODEL AND SERIAL NUMBERS

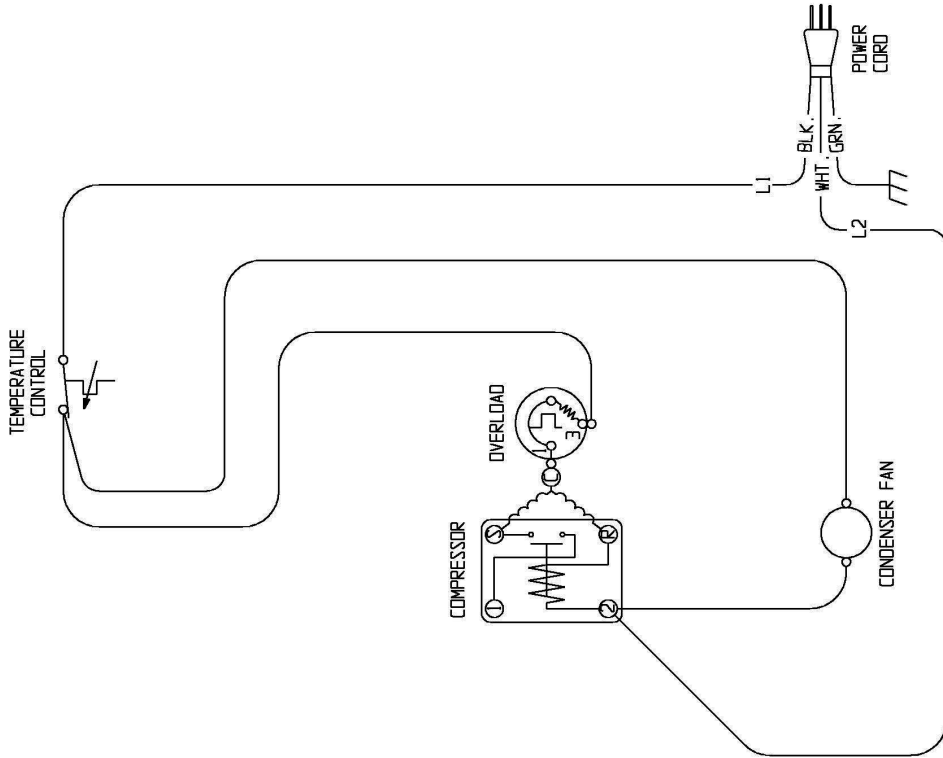

WIRING DIAGRAM  
MODEL SKFS2

SEE SERIAL PLATE FOR CORRECT POWER SOURCE  
115 VAC, 60 Hz, 1 PHASE  
OR  
220 VAC, 60/50 Hz, 1 PHASE

