

Technical Manual and Replacement Parts List

Refrigerated Pizza Prep Table

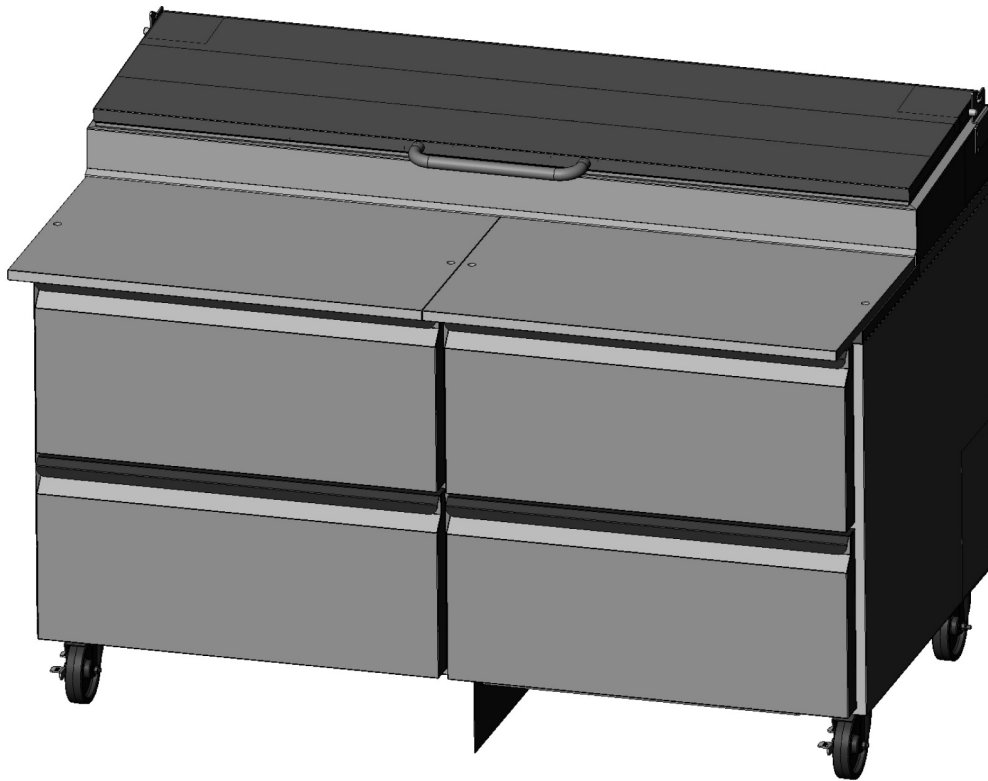

MODEL: SKPZ60D2/C5

SILVER KING REFRIGERATION INC.

1600 Xenium Lane North, Minneapolis, MN 55441-3787
Phone (763) 923-2441

FORM NO. 37064 REV C

SILVER KING®

Specifications Subject to Change Without Notice.



TECHNICAL MANUAL
SILVER KING PREPARATION TABLES
MODEL SKPZ60D2/C5

Thank you for purchasing Silver King food service equipment. Our goal is to provide our customers with the most reliable equipment in the industry today. Please read this manual and the accompanying warranty information before operating your new Silver King unit. Be sure to complete and mail the warranty card within 10 days of purchase to validate your warranty.

INSPECT FOR DAMAGE AND UNCRATE

Upon delivery of your new Silver King unit, uncrate at once to inspect for possible freight damage following the instructions printed on the exterior of the container. Report any damages to the carrier responsible for transportation and promptly present a claim for any evidence of mishandling. Save all packaging materials if a claim is filed.

INSTALLATION

The stainless steel exterior of the cabinet has been protected by a plastic covering during manufacturing and shipping. This covering can be readily stripped before installation. After removing this covering, wash the interior and exterior surfaces using a warm, mild soapy water solution and a sponge or cloth, rinse with clean water and dry.

Legs/Casters

The unit comes with legs or casters. To install them, tip the unit on its back and thread the legs or casters into the four tapping plates in the base of the unit. The casters with brakes should be installed at the front of the cabinet. Make sure that they are installed tightly to prevent future thread wear. Periodically check for tightness.

Condenser Filter Screen

The Condenser Filter Screen, Screen Pull and Filter Guides are packaged inside the unit. The instructions for installing these parts are included in this technical manual. Do not operate the unit without the filter screen installed!

Pans and Pan Supports

The Pans and Pan Supports are packaged with the unit.

Cutting Board

The Cutting Boards are shipped with the cabinet. The Cutting Boards have two holes in them that align with studs installed on the top of the cabinet. To install the Cutting Boards place the back of the boards under the lip in front of the raised rail and set them down so the studs on the cabinet top align with the holes in the Cutting Boards. The Cutting Boards are reversible to extend wear.

Drawers

To remove the drawers for cleaning, simply open them fully, lift up on the front of the drawer to remove the front wheels from the drawer tracks, continue to slide the drawer out until the rear wheels reach the end of the tracks and lift the drawer out of the tracks. To reinstall the drawer, insert the rear wheels of the drawer into the drawer tracks and slide the drawer back until the front wheels on the drawer can be inserted into the track, push the drawer into the cabinet. The drawer pans can be removed by lifting them out with the drawer extended. The drawer tracks can be removed for cleaning when the drawers are removed from the cabinet. With the track fully in the cabinet, simply lift up on the drawer track to remove it from the cabinet. The drawer slide system is rated for a maximum load of 200 pounds. The drawers are not designed for or intended to be used as a surface to stand on. At no time should the drawers be extended and used as a platform for standing on to reach elevated equipment.

Location

When locating your new refrigerator, convenience and accessibility are important considerations, but the following installation guidelines must be followed:

- Always avoid placing the refrigerator adjacent to an oven, heating element or hot air source that would affect the operation of the unit.
- For proper ventilation the bottom front of the unit must not be obstructed. The unit must be on legs or casters to raise it off the floor. The unit can be installed tight on the sides and back.
- The unit must be level or tilted backwards slightly.

Electrical Connections

Be sure to check the data plate, located on the liner of the cabinet, for required voltage prior to connecting the unit to power. The specifications on the data plate supersede any future discussion.

The standard refrigerator is equipped with an eight (8) foot power cord that requires a 115 Volt, 60 Cycle, 1 Phase properly grounded electrical receptacle. The power cord comes with a 3 prong plug for grounding purposes. Any attempt to cut off the grounding spike or to connect to an ungrounded adapter plug will void the warranty, terminate the manufacturers responsibility and could result in serious injury.

The circuit must be protected with a 15 or 20 ampere fuse or breaker. The unit must be isolated on a circuit and not plugged into an extension cord.

OPERATION

Initial start up

After satisfying the installation requirements, the refrigerator is ready to start. The Compressor will start when the power cord is connected to the required power source. If the Compressor does not start when the unit is initially plugged in, check to make sure that the Temperature Control is not in the off position. Allow the unit to run for two hours before loading it with product. When loading the unit with product, take care not to block the air flow in the cabinet as this would affect the units performance.

Temperature Control

The Temperature Control is located on the back wall of the cabinet liner and is factory set to maintain an average cabinet temperature of approximately 36 to 40 Deg F.. To obtain colder temperatures turn the Temperature Control stem clockwise and vice versa. Allow the unit a minimum of one hour to respond to a control setting adjustment. To save energy, the rail cover should be closed when rail access is not required for a period of 10 minutes or more.

Defrost

Your Silver King refrigerator is an automatic defrost unit and no additional plumbing is required. Automatic defrosting is accomplished when frost buildup on the Evaporator Coil is cleared during Compressor off cycles. Defrost water is collected in a pan located in the compressor compartment where it is evaporated into the room air. It is important that the unit be installed level to allow proper drainage of the defrost water.

MAINTENANCE

Preventative maintenance is minimal although these few steps are very important to continued operation and maximizing the life of the appliance.

Cabinet Surfaces

The cabinet interior is aluminum and stainless steel and the exterior is stainless steel. These surfaces should be cleaned periodically with a solution of warm water and mild soap, rinsed and wiped dry with a soft cloth. A good stainless steel cleaner can also be used. Should a surface become stained, do not attempt to clean with an abrasive cleanser or scouring pad. Use a soft cleanser and rub with the grain of the metal to avoid scratching the surface. Do not use chlorinated cleaners. Always rinse well and dry after cleaning.

Condenser

Periodically the Condenser Filter Screen must be cleaned. The Condenser Filter Screen is located on the bottom of the cabinet. To clean it simply pull it out the front of the unit using the Filter Screen Pull and rinse it in a stream of water. Dry the screen by tapping it on a counter or floor. Replace the filter screen by placing it into the filter screen tracks on the bottom of the unit and sliding it all the way to the rear of the cabinet. Do not operate the unit without the filter sreen installed!

Drawer Gasket

The Door Gasket will collect dirt and should be wiped clean with a warm, mild soapy water solution to extend its life and assure maximum cabinet performance and life.

MODEL _____ SERIAL NO. _____ DATE INSTALLED _____

FILTER GUIDES AND SCREEN INSTALLATION INSTRUCTIONS

MODELS: SKF48, SKP7218, SKP7230, SKPZ60, SKPZ92, SKR48, SKP488, SKP4812, SKP4818

DO NOT OPERATE UNIT WITHOUT FILTER SCREEN AND AIR CURTAIN INSTALLED

1. Disconnect unit from power source.
2. Tip the unit on its back and loosen the 2 screws along the top edge of the base.
3. Insert tab on the end of the filter guide with curtain into the slot located along the lower edge of the base unit.
4. Slip the opposite end of the filter guide with curtain under the screw head loosened in step 2, pull forward, and tighten screw to secure the filter guide to base.
5. Repeat step 4 with right filter guide.
6. Insert filter screen into tracks formed by the guides and slide back until the screen stops.
7. Install legs or casters.
8. Return unit to original upright position.

This kit includes:

- Filter guide with curtain
- Right filter guide
- Filter screen

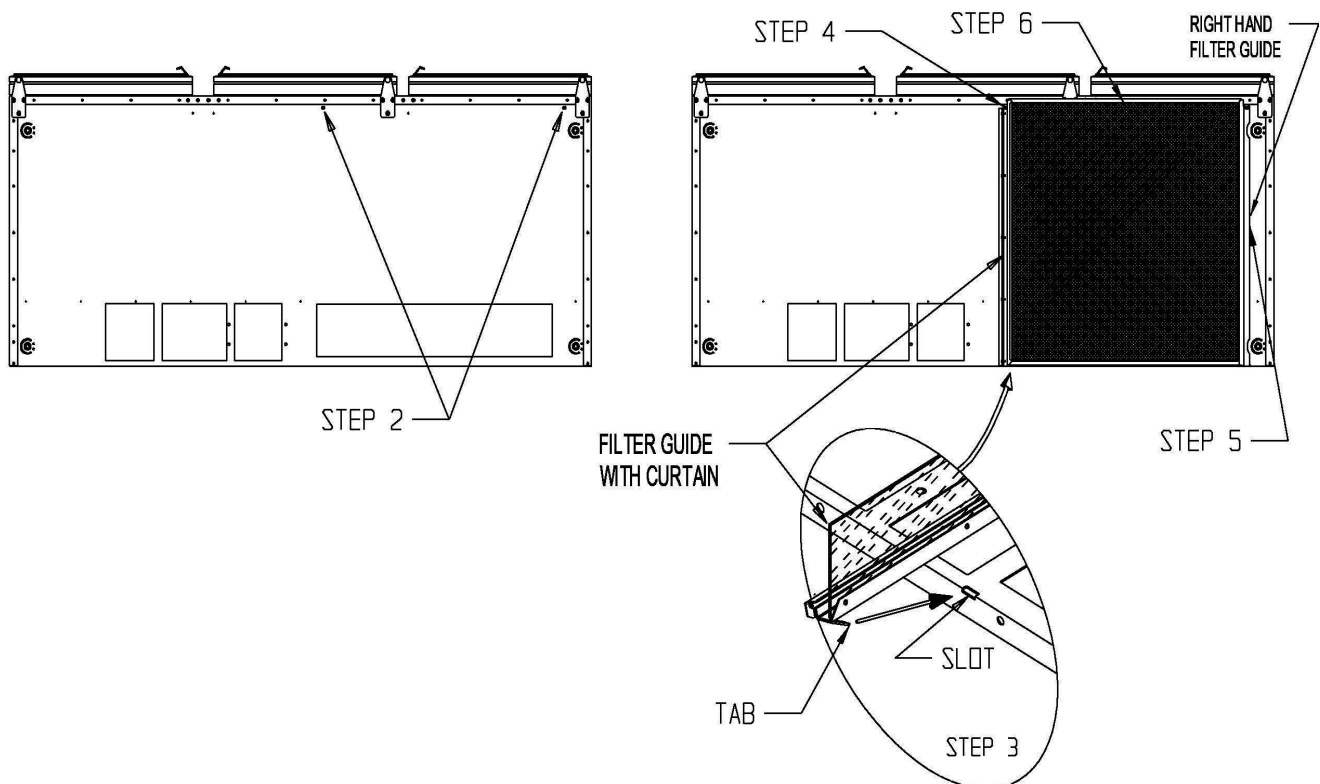

Evaporator Drain Cleaning Instructions

- 1) Remove the pans and adapter bars from the left side of the unit.
- 2) There is a 5" X 5" access plate located on the inside left of the unit as shown in the picture below.
- 3) Loosen the two screws on the access plate and rotate the plate counter clockwise. The drain hole is located directly behind the access hole.
- 4) Clear any debris that may be clogging the drain hole.
- 5) Inspect the drain area. If there is excessive debris, the evaporator panel will need to be removed to clean the entire drain pan area.

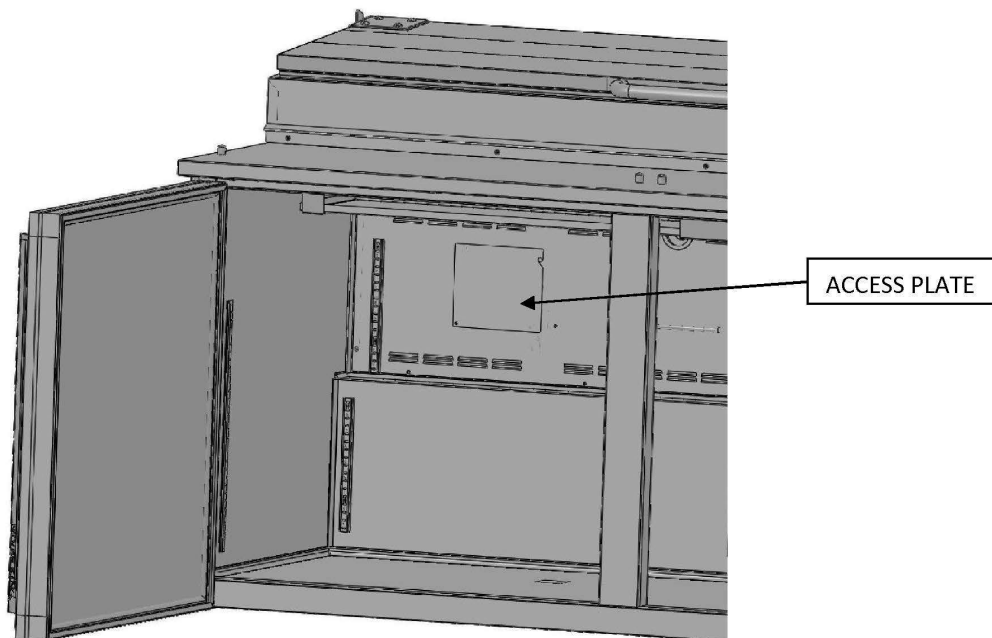

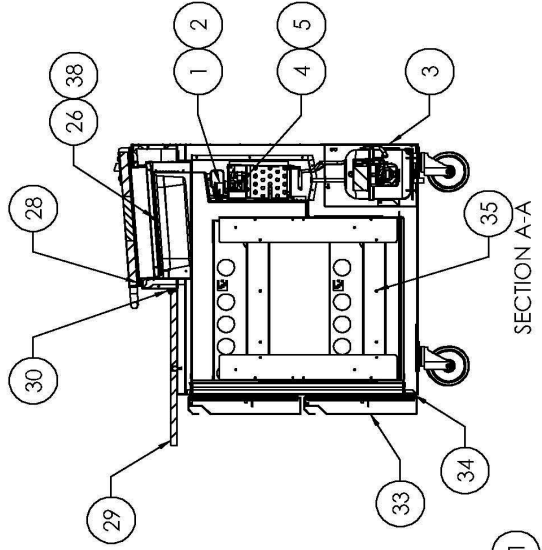
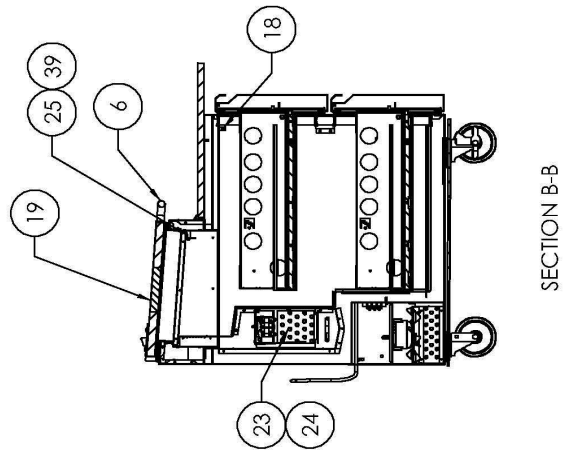
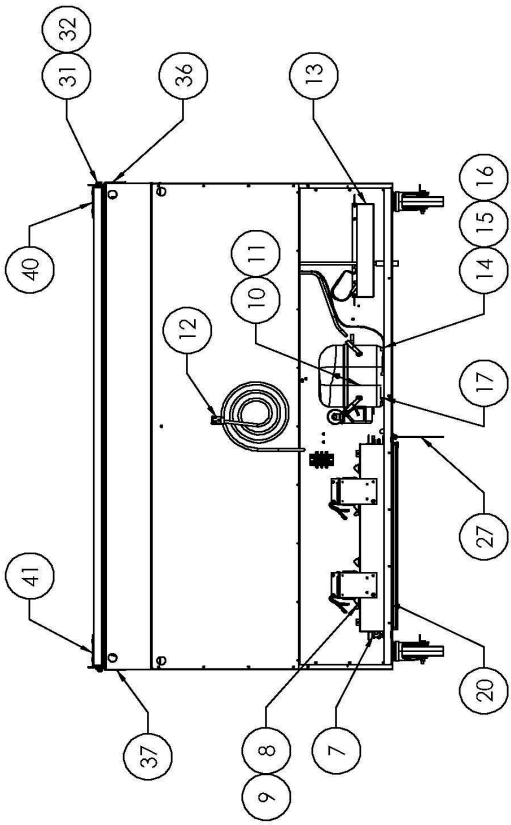

REPLACEMENT PARTS LIST - SKPZ60D2/C5

ITEM NO.	PART DESCRIPTION	PART NO.
1	TEMPERATURE CONTROL PLATE	20653
2	TEMPERATURE CONTROL	20889
3	BACK PANEL LH	34940
	BACK PANEL RH	34941
4	FAN MOTOR EVAPORATOR 115V	21251-2
5	FAN BLADE EVAPORATOR	99190
6	HANDLE COVER	26930
7	CONDENSER COIL	43762
8	FAN MOTOR CONDENSER 115V	22048
9	FAN BLADE CONDENSER	24194
10	COMPRESSOR 115V (WITH DRIER & ELECTRICALS)	10343-75
11	COMPRESSOR ELEC 115V (OVERLOAD, RELAY, ETC)	10344-75
12	POWER CORD 115V	43263
13	CONDENSATE PAN ASSEMBLY 115V	24966
14	GROMMET - COMPRESSOR MOUNT	20481
15	HAIRPIN CLIP	98106
16	WASHER - COMPRESSOR MOUNT	22401
17	DRIER	23793
18	TEMPERATURE INDICATOR	22409
19	RAIL COVER	36056
20	FILTER SCREEN	30939
21	KIT PLATE CASTERS	10314-75
23	EVAPORATOR COIL	63942
24	HEAT EXCHANGER 115V	24322
25	PAN SUPPORT - FRONT	35163
26	PAN ADAPTER BAR	25569
27	FILTER AND GUIDE KIT	27263-7
28	GASKET - LID	26307
29	KIT CUTTING BOARDS	10330-38
30	CUTTING BOARD REAR BRACKET	32827
31	THREADED KNOB	24305
32	PIN PIVOT	23503
33	DRAWER ASSEMBLY	37060
34	DRAWER GASKET	34872
35	SLIDE 22 IN CENTER MEMBER RH	34647
	SLIDE 22 IN CENTER MEMBER LH	34648
36	HOOD BRACKET, LH	36322
37	HOOD BRACKET, RH	36323
38	PAN	27066
39	BRACKET MAIN PAN SUPPORT	35428
40	HINGE PLATE ASSEMBLY LH	36685
41	HINGE PLATE ASSEMBLY RH	36686

FORM 37062

WHEN ORDERING REPLACEMENT PARTS, PLEASE PROVIDE MODEL AND SERIAL NUMBERS

SEE SERIAL PLATE FOR CORRECT POWER SOURCE
 115 VAC, 60Hz, 1PHASE
 OR
 220 VAC, 60/50Hz, 1PHASE

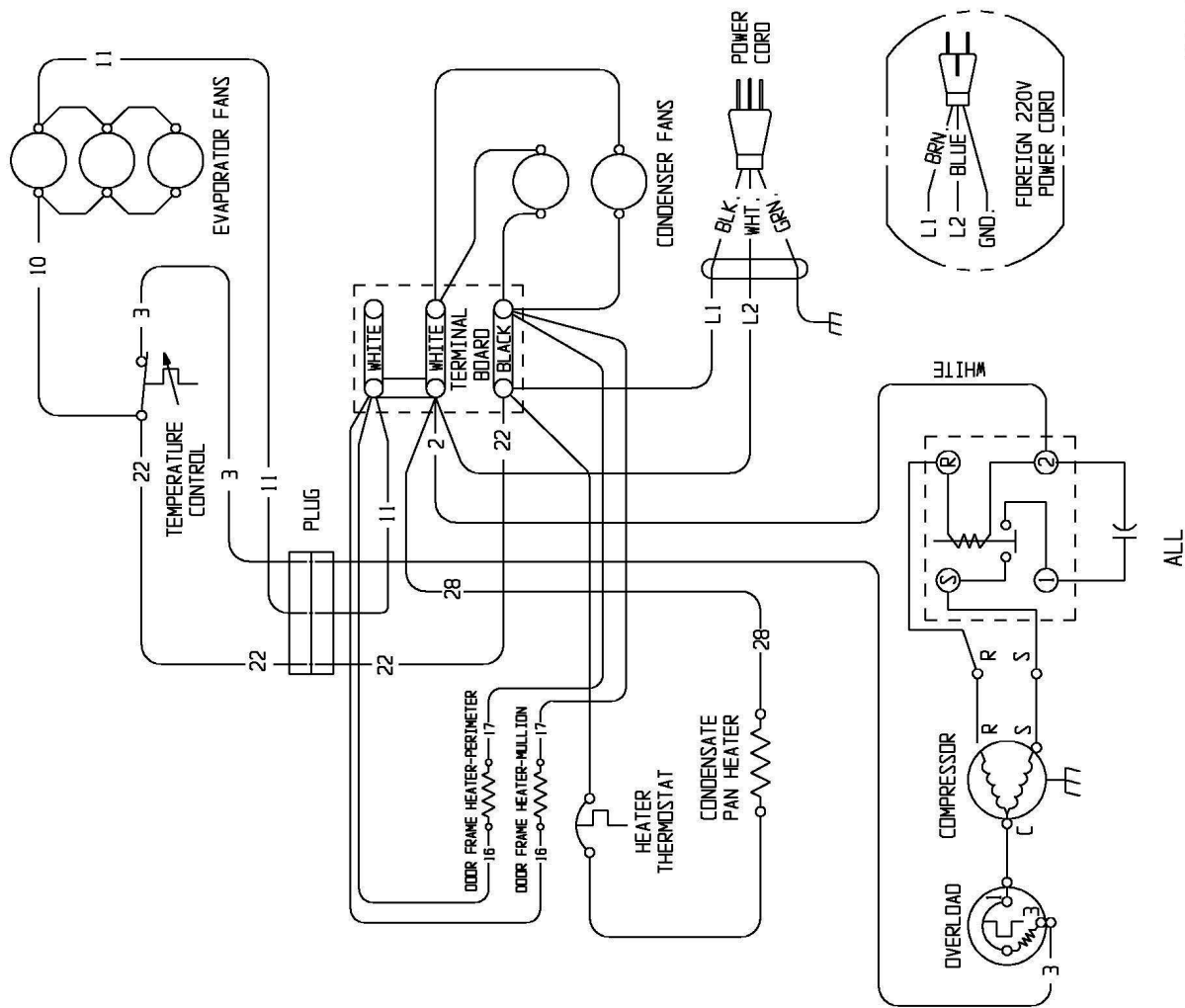
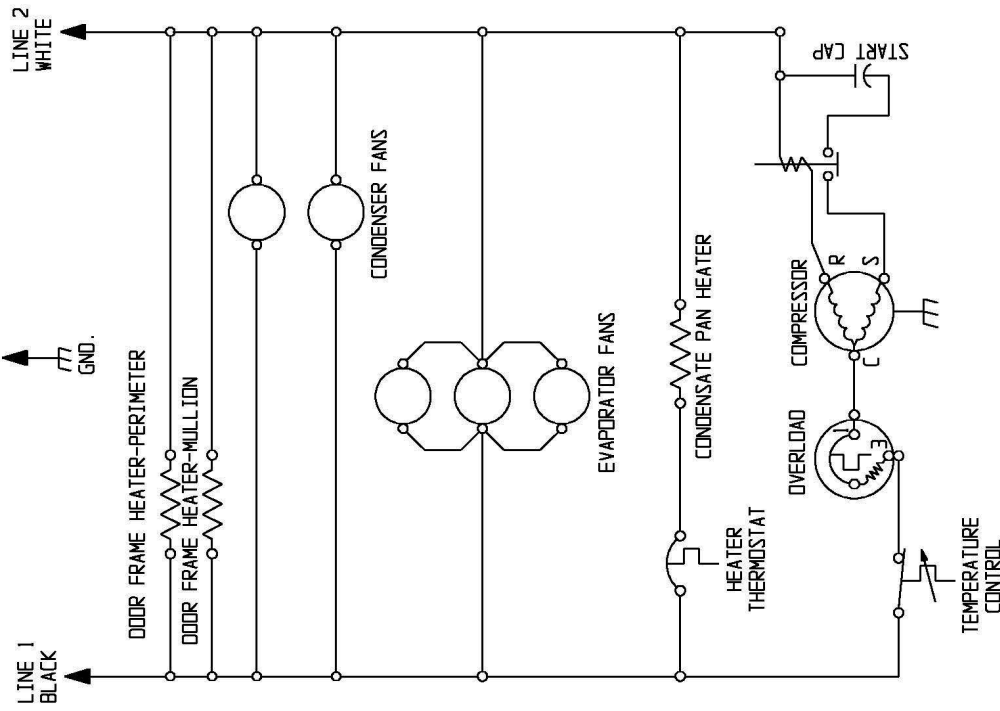

WIRING DIAGRAM

MODELS: SKP6016, SKP6024, SKP760
 SKP6016D, SKP6024D, SKP2600