

Technical Manual and Replacement Parts List

Refrigerated Pizza Prep Table

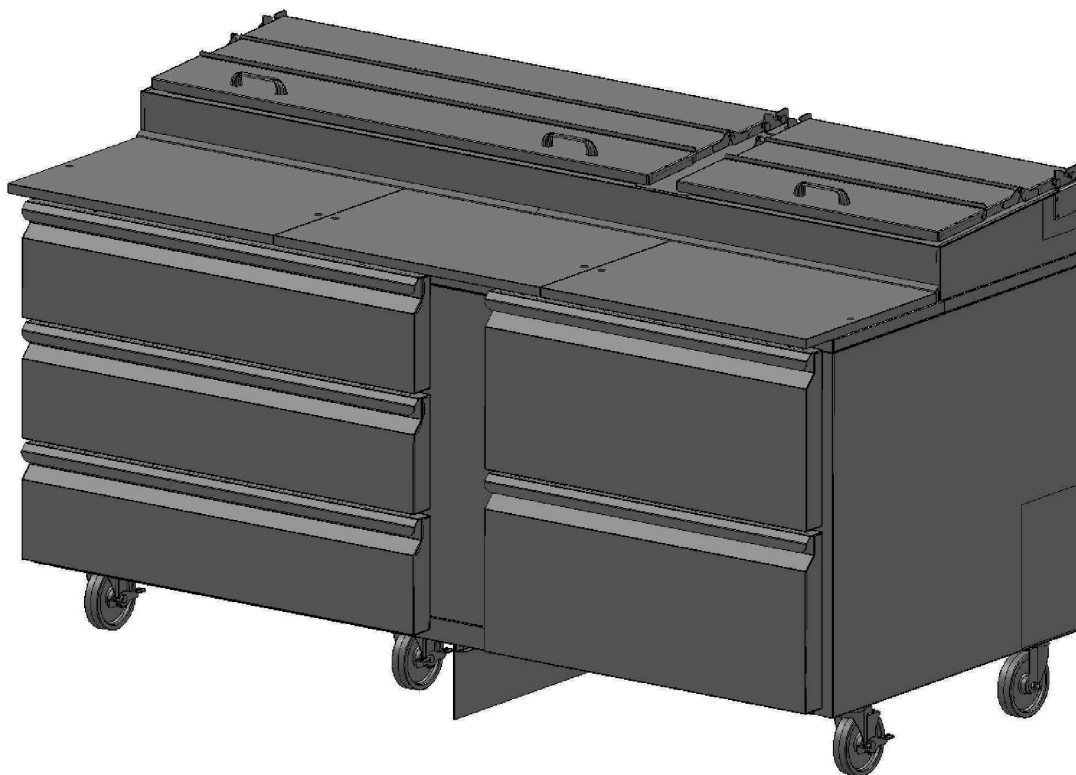

**MODEL: SKPZ72D/C3
SKPZ72D/CSA3**

1600 Xenium Lane North, Minneapolis, MN 55441-3787
Phone (763) 923-2441

SILVER KING[®]

FORM NO. 38162 REV F 8/2016

Specifications Subject to Change Without Notice.



TECHNICAL MANUAL
SILVER KING PREPARATION TABLES
MODEL SKPZ72D/C3

Thank you for purchasing Silver King food service equipment. Our goal is to provide our customers with the most reliable equipment in the industry today. Please read this manual and the accompanying warranty information before operating your new Silver King unit.

INSPECT FOR DAMAGE AND UNCRATE

Upon delivery of your new Silver King unit, uncrate at once to inspect for possible freight damage following the instructions printed on the exterior of the container. Report any damages to the carrier responsible for transportation and promptly present a claim for any evidence of mishandling. Save all packaging materials if a claim is filed.

INSTALLATION

The stainless steel exterior of the cabinet has been protected by a plastic covering during manufacturing and shipping. This covering can be readily stripped before installation. After removing this covering, wash the interior and exterior surfaces using a warm, mild soapy water solution and a sponge or cloth, rinse with clean water and dry.

Legs/Casters

The unit comes with legs or casters. To install them, tip the unit on its back and thread the legs or casters into the four tapping plates in the base of the unit. The casters with brakes should be installed at the front of the cabinet. Make sure that they are installed tightly to prevent future thread wear. Periodically check for tightness.

Pans and Pan Supports

The Pans and Pan Supports are packaged with the unit.

Cutting Board

The Cutting Boards are shipped with the cabinet. The Cutting Boards have two holes in them that align with studs installed on the top of the cabinet. To install the Cutting Boards place the back of the boards under the lip in front of the raised rail and set them down so the studs on the cabinet top align with the holes in the Cutting Boards. The Cutting Boards are reversible to extend wear.

Drawers

To remove the drawers for cleaning, simply open them fully, lift up on the front of the drawer to remove the front wheels from the drawer tracks, continue to slide the drawer out until the rear wheels reach the end of the tracks and lift the drawer out of the tracks. To reinstall the drawer, insert the rear wheels of the drawer into the drawer tracks and slide the drawer back until the front wheels on the drawer can be inserted into the track, push the drawer into the cabinet. . The drawer pans can be removed by lifting them out with the drawer extended. The drawer tracks can be removed for cleaning when the drawers are removed from the cabinet. With the track fully in the cabinet, simply lift up on the drawer track to remove it from the cabinet. The drawer slide system is rated for a maximum load of 200 pounds. The drawers are not designed for or intended to be used as a surface to stand on. At no time should the drawers be extended and used as a platform for standing on to reach elevated equipment.

Location

When locating your new refrigerator, convenience and accessibility are important considerations, but the following installation guidelines must be followed:

- Always avoid placing the refrigerator adjacent to an oven, heating element or hot air source that would affect the operation of the unit.
- For proper ventilation the bottom front of the unit must not be obstructed. The unit must be on legs or casters to raise it off the floor. The unit can be installed tight on the sides and back.
- The unit must be level or tilted backwards slightly.

Electrical Connections

Be sure to check the data plate, located on the liner of the cabinet, for required voltage prior to connecting the unit to power. The specifications on the data plate supersede any future discussion.

The standard refrigerator is equipped with an eight (8) foot power cord that requires a 115 Volt, 60 Cycle, 1 Phase properly grounded electrical receptacle. The power cord comes with a 3 prong plug for grounding purposes. Any attempt to cut off the grounding spike or to connect to an ungrounded adapter plug will void the warranty, terminate the manufacturers responsibility and could result in serious injury.

The circuit must be protected with a 15 or 20 ampere fuse or breaker. The unit must be isolated on a circuit and not plugged into an extension cord.

OPERATION

Initial start up

After satisfying the installation requirements, the refrigerator is ready to start. The Compressor will start when the power cord is connected to the required power source. If the Compressor does not start when the unit is initially plugged in, check to make sure that the Temperature Control is not in the off position. Allow the unit to run for two hours before loading it with product. When loading the unit with product, take care not to block the air flow in the cabinet as this would affect the units performance.

Temperature Control

The Temperature Control is located on the back of the cabinet and is factory set to maintain an average cabinet temperature of approximately 38 Deg F. To obtain colder temperatures, press and hold the set button until the set point value flashes. Use the up or down arrow buttons to change the value and then press the set button again. Allow the unit a minimum of one hour to respond to a control setting adjustment.

Defrost

Your Silver King refrigerator is an automatic defrost unit and no additional plumbing is required. Automatic defrosting is accomplished when frost buildup on the Evaporator Coil is cleared during Compressor off cycles. Defrost water is collected in a pan located in the compressor compartment where it is evaporated into the room air. It is important that the unit be installed level to allow proper drainage of the defrost water.

MAINTENANCE

Preventative maintenance is minimal although these few steps are very important to continued operation and maximizing the life of the appliance.

Cabinet Surfaces

The cabinet interior is aluminum and the exterior is stainless steel. These surfaces should be cleaned periodically with a solution of warm water and mild soap, rinsed and wiped dry with a soft cloth. A good stainless steel cleaner can also be used. Should a surface become stained, do not attempt to clean with an abrasive cleanser or scouring pad. Use a soft cleanser and rub with the grain of the metal to avoid scratching the surface. Do not use chlorinated cleaners. Always rinse well and dry after cleaning.

Condenser

Periodically, accumulated dust must be removed from the condenser. First, disconnect the unit from the power supply. To clear the dust, vacuum or brush the condenser at the bottom rear of the cabinet. This will need to be done regularly to maintain the compressor warranty!

Drawer Gasket

The Drawer Gasket will collect dirt and should be wiped clean with a warm, mild soapy water solution to extend its life and assure maximum cabinet performance and life.

MODEL _____ SERIAL NO. _____ DATE INSTALLED _____

AIR CURTAIN INSTALLATION INSTRUCTIONS

MODELS: SKP278, SKP2712, SKP2727/D, SKR27D, SKR27D, SKR48, SKF48, SKP4812, SKP4818/D, SKR60, SKP6016, SKP6024/D, SKP7218, SKP7230, SKPZ60/D, SKPZ92/D

DO NOT OPERATE UNIT WITHOUT AIR CURTAIN INSTALLED

1. Disconnect unit from power source.
2. Tip the unit on its back and loosen the center screw along the front edge of the base.
3. Insert the tab on the end of the air curtain into the slot located along the rear lower edge of the unit.
4. Slip the opposite end of the air curtain under the screw head loosened in step 2, pull forward, and tighten screw to secure the air curtain to the base.
5. Install legs or casters.
6. Return unit to original upright position.

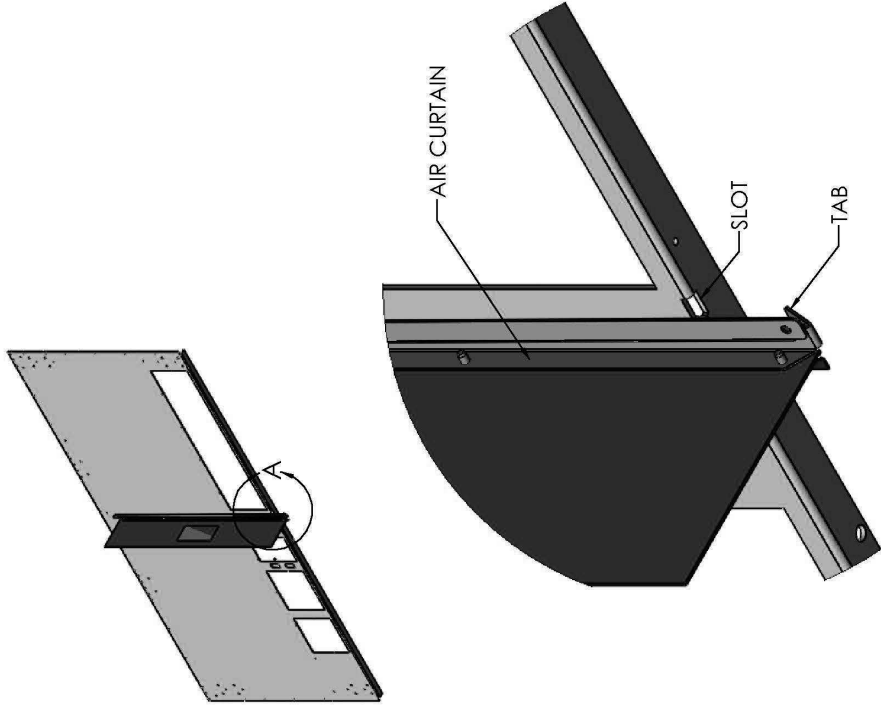
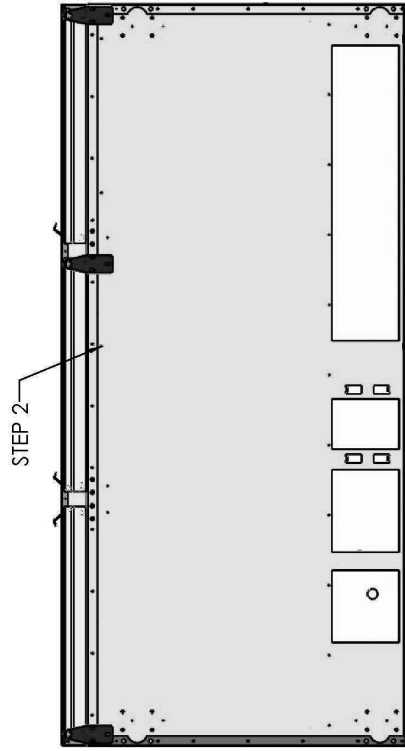

STEP 3

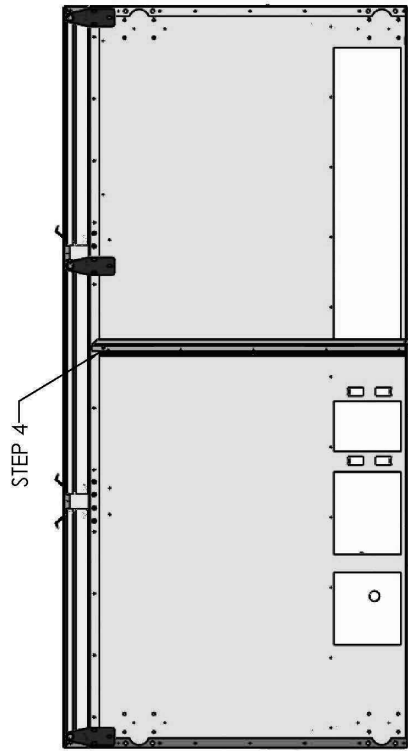

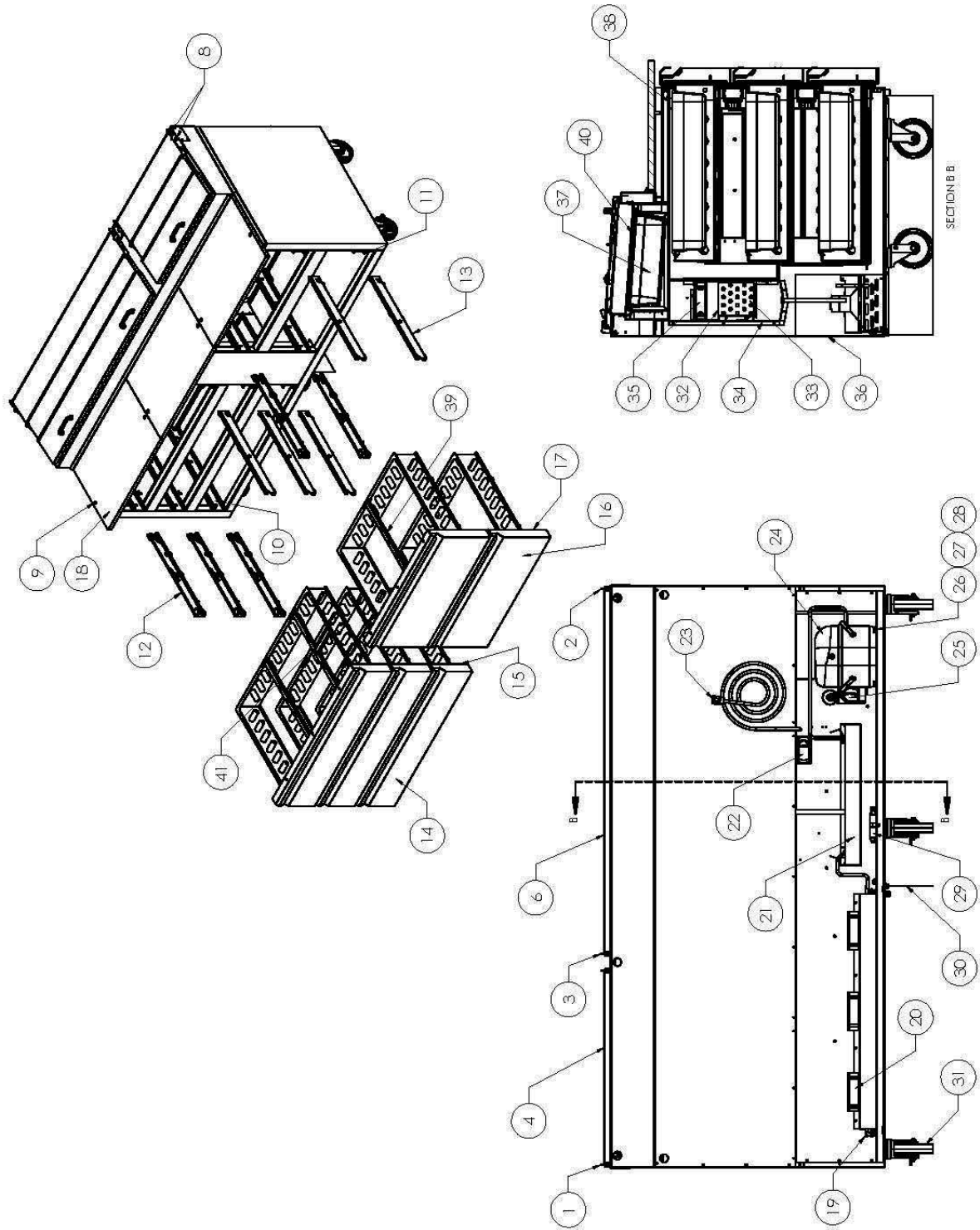

REPLACEMENT PARTS LIST - SKPZ72D/C3

ITEM NO.	PART DESCRIPTION	PART NO.
1	BRACKET COVER RH	37573
2	BRACKET COVER LH	37572
3	BRACKET COVER CENTER	38139
4	TRI FOLD LID ASSEMBLY SMALL	38140
6	TRI FOLD LID ASSEMBLY LARGE	37581
8	PIVOT PIN	23503
9	KNOB THREADED	24305
10	DRAWER SLIDE CABINET LH	34646
11	DRAWER SLIDE CABINET RH	34645
12	DRAWER SLIDE CENTER LH	34648
13	DRAWER SLIDE CENTER RH	34647
14	DRAWER ASSEMBLY 2 1/2 PAN	37920
15	GASKET DRAWER 2 1/2 PAN	37917
16	DRAWER ASSEMBLY 2 PAN	37822
17	GASKET DRAWER 2 PAN	34872
18	KIT CUTTING BOARDS	10330-41
19	CONDENSER COIL	24801
20	FAN MOTOR CONDENSER 115V	37736
	FAN MOTOR CONDENSER 230V	37814
21	CONDENSATE PAN ASSEMBLY	38142
22	TEMPERATURE CONTROL (PROGRAMMED)	39565
23	POWER CORD 115V	32199
	POWER CORD 230V UK	25454
24	COMPRESSOR W/ ELECTRICALS 115V	10343-76
	COMPRESSOR W/ ELECTRICALS 230V/60HZ	10343-70
25	ELECTRICAL KIT (RELAY,OVERLOAD,CAPACITOR) 115V	10344-76
	ELECTRICAL KIT (RELAY,OVERLOAD,CAPACITOR) 230V/60HZ	10344-70
26	GROMMET COMPRESSOR MOUNT	20481
27	WASHER COMPRESSOR MOUNT	22401
28	HAIRPIN CLIP COMPRESSOR MOUNT	98106
29	DRIER	22677
30	AIR CURTAIN ASSEMBLY	26498
31	CASTER KIT 5" (6 PER)	10314-76
32	EVAPORATOR	37941
33	CAPILLARY TUBE	31236
34	TEMPERATURE PROBE	30660
35	FAN MOTOR EVAPORATOR 115V	37736
	FAN MOTOR EVAPORATOR 230V	37814
36	REAR PANEL	37856
37	PAN 1/3 SIZE 4" DEEP	27066
38	TEMPERATURE INDICATOR	22409
39	PAN ADAPTER DRAWER 20.5"	28726
40	PAN ADAPTER RAIL 12.125"	25576
41	PAN ADAPTER DRAWER 6.12"	39643

FORM 38161

WHEN ORDERING REPLACEMENT PARTS, PLEASE PROVIDE MODEL AND SERIAL NUMBERS.

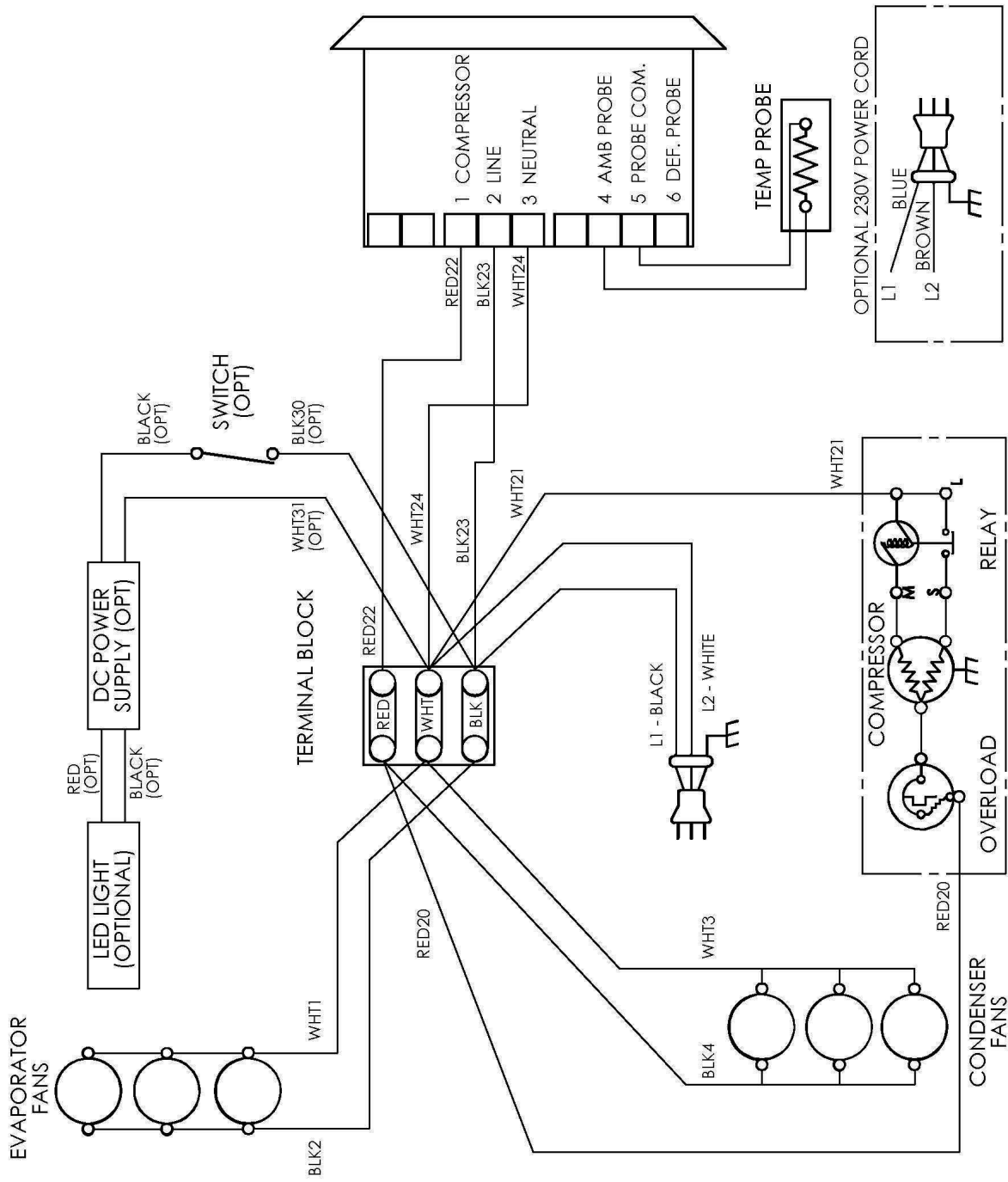

WIRING DIAGRAM 37987
REV A

SILVER KING LIMITED WARRANTY

Silver King Refrigeration warrants to the original purchaser of Silver King refrigerated equipment that the equipment shall be free from defects in material and workmanship under normal use and service as outlined in the Technical Manual. This limited warranty shall apply for a period of one (1) year from the date of original purchase. The Compressor will carry an additional four (4) year warranty. The warranty registration card attached must be filled out and returned within 10 days of installation or the warranty will be void. All warranties are subject to specific limitations outlined below.

This limited warranty does not apply to repair or replacement required as a result of carelessness, neglect and/or abuse, including improper installation, incorrect voltage supply, tampering with or altering components and/or equipment or failure to perform proper maintenance. Equipment damaged in transit, by fire, flood or an act of God is not covered. This limited warranty does not include freight, handling, installation, labor (following the one (1) year labor warranty period) or other incidental or consequential costs including product and/or economic loss. This limited warranty is in lieu of all other warranties, express or implied, including those of merchantability, and is non-transferable.

Specific provisions of this limited warranty are as follows:

One (1) Year Parts Warranty

Silver King warrants to the original purchaser of new Silver King equipment that such equipment and all parts thereof will be free of defects in material and workmanship, under normal use and service, for a period of one (1) year from the date of original purchase or 18 months from the date of shipment from the factory, whichever comes first, subject to all terms and conditions herein.

This warranty is limited to repairing or replacing any parts that, at Silver King's discretion, are deemed to be defective within the time period covered by this warranty. The one year parts warranty covers reasonable freight and handling charges. It does not cover special handling charges or expedited means for transport. Use of non-OEM parts may, at Silver King's discretion, void this warranty. If approved, warranty credit for non-OEM parts will be issued at the OEM cost.

Replacement parts sold separately are warranted for 90-days from date of purchase.

Five (5) Year Compressor Warranty

Silver King warrants to the original purchaser for a period of five (5) years from the date of original purchase or five (5) years and six (6) months from the date of shipment from the factory, whichever comes first, that it will replace the compressor with one of similar design and capacity, exclusive of delivery and installation charges, if it is found to Silver King's satisfaction to be inefficient or inoperative due to defects in material or factory workmanship. It is the owner's responsibility to return the serial plate of the defective compressor, or at Silver King's option the complete compressor, to the factory. Failure to do so will void the warranty.

Five (5) Year Heavy Duty Drawer Slide Warranty

Silver King warrants to the original purchaser for a period of five (5) years from the date of original purchase or five (5) years and six (6) months from the date of shipment from the factory, whichever comes first, that it will replace the heavy duty drawer slides with one of similar design and capacity, exclusive of delivery and installation charges, if it is found to Silver King's satisfaction to be inefficient or inoperative due to defects in material or factory workmanship.

One (1) Year Labor Warranty

Silver King warrants to the original purchaser for a period of one (1) year from the date of purchase or 18 months from the date of shipment from the factory, whichever comes first, a limited service labor warranty on Silver King refrigerated equipment subject to the following terms;

A factory issued Service Authorization Number must be obtained prior to work being performed under the labor warranty. Call your supplier or Silver King. Claims submitted without a Service Authorization Number will be paid at Silver King's discretion.

The labor warranty includes standard straight time labor charges in accordance with Silver King's Labor Warranty Guidelines and reasonable travel time, as determined by Silver King.

The warranty does not cover original installation, startup, normal adjustments or maintenance. Normal adjustments and maintenance include, but are not limited to; temperature control adjustments, temperature indicator calibrations, coil and filter cleaning, condensate drain cleaning.

A second service call for a related failure is not covered.

Use of refrigerants other than specified on the equipment serial plate voids the warranty.

All claims must include; model and serial number of equipment, date of purchase, date of failure, and a copy of the service invoice detailing the defect and service performed. No claim will be processed without this information. All claims must be filed within 60 days from date of service.