

Technical Manual and Replacement Parts List

Refrigerated Chef Base



MODELS SKRCB79H (SHOWN)
SKRCB84H

SILVER KING REFRIGERATION INC.

1600 Xenium Lane North, Minneapolis, MN 55441-3787
Phone (763) 923-2441

SILVER KING®

FORM NO. 36880 REV C

Specifications Subject to Change Without Notice.



TECHNICAL MANUAL
SILVER KING PREPARATION TABLES
MODELS SKRCB79H AND SKRCB84H

Thank you for purchasing Silver King food service equipment. Our goal is to provide our customers with the most reliable equipment in the industry today. Please read this manual and the accompanying warranty information before operating your new Silver King unit. Be sure to complete and mail the warranty card within 10 days of purchase to validate your warranty.

INSPECT FOR DAMAGE AND UNCRATE

Upon delivery of your new Silver King unit, uncrate at once to examine and test for possible damage following the instructions printed on the exterior of the container. Report any damages to the carrier responsible for transportation and promptly present a claim for any evidence of mishandling. Save all packaging materials if a claim must be filed.

INSTALLATION

The stainless steel exterior of the cabinet has been protected by a plastic covering during manufacturing and shipping. This covering can be readily stripped before installation. After removing this covering, wash the interior and exterior surfaces using a warm, mild soapy water solution and a sponge or soft cloth. Rinse afterward with clean water and wipe dry. Do not use chlorinated cleaners.

Location

When locating your new Silver King unit, convenience and accessibility are important considerations, but the following installation guidelines must be observed;

- When stacking cooking equipment on these units observe the following load limits: Models SKRCB50H and SKRCB60H have a maximum load limit of 950 pounds and models SKRCB79H and SKRCB84H have a maximum limit of 1100 pounds of stacked equipment.
- Stacked cooking equipment should not transfer excessive heat down onto the cabinet. When cabinet surface temperatures exceed 150° F damage to cabinet insulation may occur.
- The unit must be level.
- Allow at least 2 inches of space on the right and back side, no space on the left side and leave the top open for proper air flow.
- All caster brakes should be set when the unit is positioned in its intended place.

Legs/Casters

The unit comes with legs or casters (four on models SKRCB50H and 60H and six on models SKRCB79H and 84H). To install them, tip the unit on its back (remove the drawers first to lighten the unit) and locate the four hex-screw patterns on the base of the unit. These hex screws are used to mount the plate casters. Remove the hex screws, align a plate caster over the four hole pattern and re-install the hex screws tightly to mount the casters. The casters with brakes should be installed at the front of the cabinet.

Drawers

To remove drawers for cleaning, simply open them fully, lift up on the front of drawer, and pull drawer out. Replace drawers in the same fashion.

With drawer removed the roller members can be removed by rocking the top of the roller member out when the roller member is pushed all the way to the back of the cabinet.

The drawer system is rated for a maximum dynamic load of 275 pounds. The drawers are not designed or intended as a surface to stand on. At no time should the drawers be extended and used as a platform for standing on to reach elevated equipment.

Electrical Connections

Be sure to check the data plate, located on the liner of the cabinet, for required voltage prior to connecting the unit to a power source. The specifications on the data plate supersede any future discussion.

The standard unit is equipped with an eight (8) foot power cord that requires a 115 Volt, 60 Cycle, 1 Phase properly grounded electrical receptacle. The power cord comes with a 3 prong plug for grounding purposes. Any attempt to cut off the grounding spike or to connect to an ungrounded adapter plug will void the warranty, terminate the manufacturers responsibility and could result in serious injury.

The circuit must be protected with a 15 or 20 ampere fuse or breaker. The unit must be isolated on a circuit and not plugged into an extension cord.

OPERATION

Initial Start Up:

After satisfying the installation requirements, the unit is ready to start. The unit will start when the power cord is connected to the required power source. Allow the unit to run a minimum of two hours before loading it with product.

Temperature Control

The Electronic Temperature Control is located behind the front grill of the unit. To access the temperature control, remove the front grill (3 screws on left side of grill). To check the temperature control set point, push and release the 'set' button on the control and the display will show the set point temperature. To adjust the set point, push and hold the 'set' button for two seconds then push the up or down arrows to adjust the set point. Either press the 'set' button again or wait 10 seconds and the control will store the new set point. Allow the unit a minimum of one hour to respond to a control setting adjustment.

Defrost

Your Silver King unit is an automatic defrost unit. No additional plumbing is required. Defrost water is collected in a pan located in the compressor compartment where it is evaporated into the room air. It is important that the unit be level so the condensate can drain properly. To initiate a defrost cycle push the top left button (melting snowflake) on the temperature control for two seconds.

MAINTENANCE

Preventative maintenance is minimal although these few steps are very important to continued operation and maximizing the life of the appliance.

Cabinet Surfaces

The cabinet interior and exterior are stainless steel. These surfaces should be cleaned periodically with a solution of warm water and mild soap. After cleaning the surfaces should be rinsed with clean water and wiped dry with a soft cloth. Stainless steel cleaners can also be used. Should a surface become stained, do not attempt to clean with an abrasive cleaner or scouring pad. Use a soft cleanser and rub with the grain of the metal to avoid scratching the surface. Always rinse well and dry after cleaning. Do not use chlorinated cleaners.

Condenser

Periodically, dust on the condenser coil must be cleaned. The condenser is located behind the front cover at the right front of the unit. Remove the front cover by removing the two (2) screws at the left side of the cover and swinging the cover off the cabinet. The condenser will be exposed. Clean the accumulated dust/debris from the condenser with a vacuum or brush. This will need to be done regularly to maintain the compressor warranty!

Casters

Check to make sure that the casters are installed tightly to the cabinet.

MODEL _____ SERIAL NO. _____ DATE INSTALLED _____

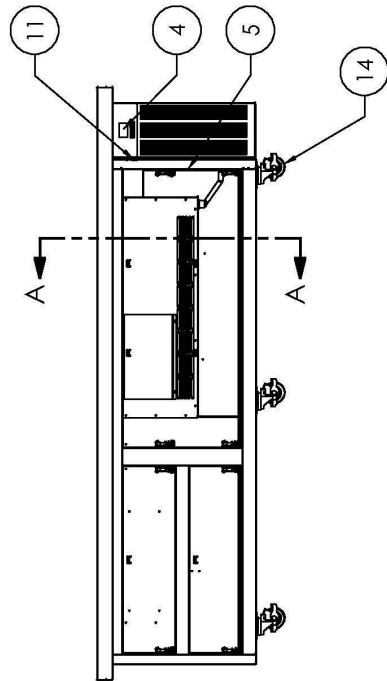
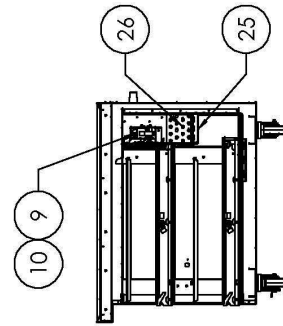
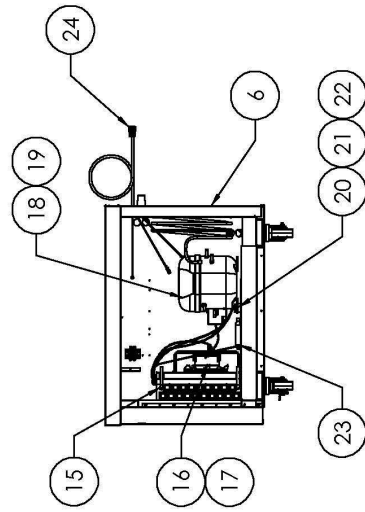
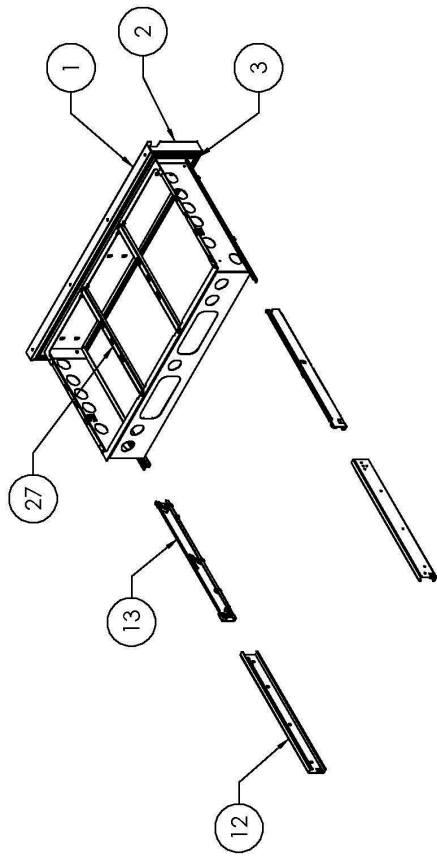
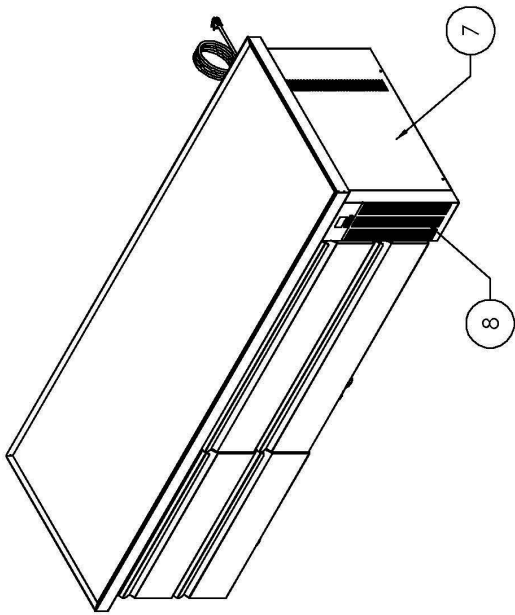

SECTION A-A

REPLACEMENT PARTS LIST - SKRCB79H/84H

ITEM NO.	PART DESCRIPTION	PART NO.
1	DRAWER HANDLE (2 PAN DRAWER)	26188
	DRAWER HANDLE (3 PAN DRAWER)	26025
2	DRAWER ASSEMBLY (2 PAN DRAWER)	36906
	DRAWER ASSEMBLY (3 PAN DRAWER)	36905
3	DRAWER GASKET (2 PAN DRAWER)	10310-55
	DRAWER GASKET (3 PAN DRAWER)	10310-56
4	TEMPERATURE CONTROL ELECTRONIC	35442
5	TEMPERATURE CONTROL TEMPERATURE PROBE	35372
6	BACK PANEL	29224
7	RIGHT END PANEL	33052
8	FRONT COVER	36433
	OVERLAY	32700
9	FAN MOTOR 115V EVAPORATOR	21251-2
10	FAN BLADE EVAPORATOR	99196
11	POWER SWITCH	26378
12	DRAWER SLIDE MEMBER RH	34503
	DRAWER SLIDE MEMBER LH	34504
13	DRAWER SLIDE ROLLER MEMBER RH	34509
	DRAWER SLIDE ROLLER MEMBER LH	34510
14	CASTER KIT 4 INCH (SIX CASTERS)	10314-78
	CASTER KIT 6 INCH (SIX CASTERS)	10314-76
15	CONDENSER COIL	25941
16	FAN MOTOR 115V CONDENSER	22048
17	FAN BLADE CONDENSER	23505
18	COMPRESSOR KIT 115/60 (SKRCB79H AND SKRCB84H)	10343-88
19	ELECTRICAL KIT 115/60 (SKRCB79H AND SKRCB84H)	10344-88
20	GROMMET - COMPRESSOR MOUNT	20481
21	CARRIAGE BOLT	99823
22	WASHER - COMPRESSOR MOUNT	20886
	NUT	98040
23	DRIER	22677
24	POWER CORD 115V	32199
25	HEAT EXCHANGER (CAP TUBE AND SUCTION LINE) (SKRCB79H/84H)	26462
26	EVAPORATOR COIL	29877
27	ADAPTER BAR	28726

FORM 36868

WHEN ORDERING REPLACEMENT PARTS, PLEASE PROVIDE MODEL AND SERIAL NUMBERS

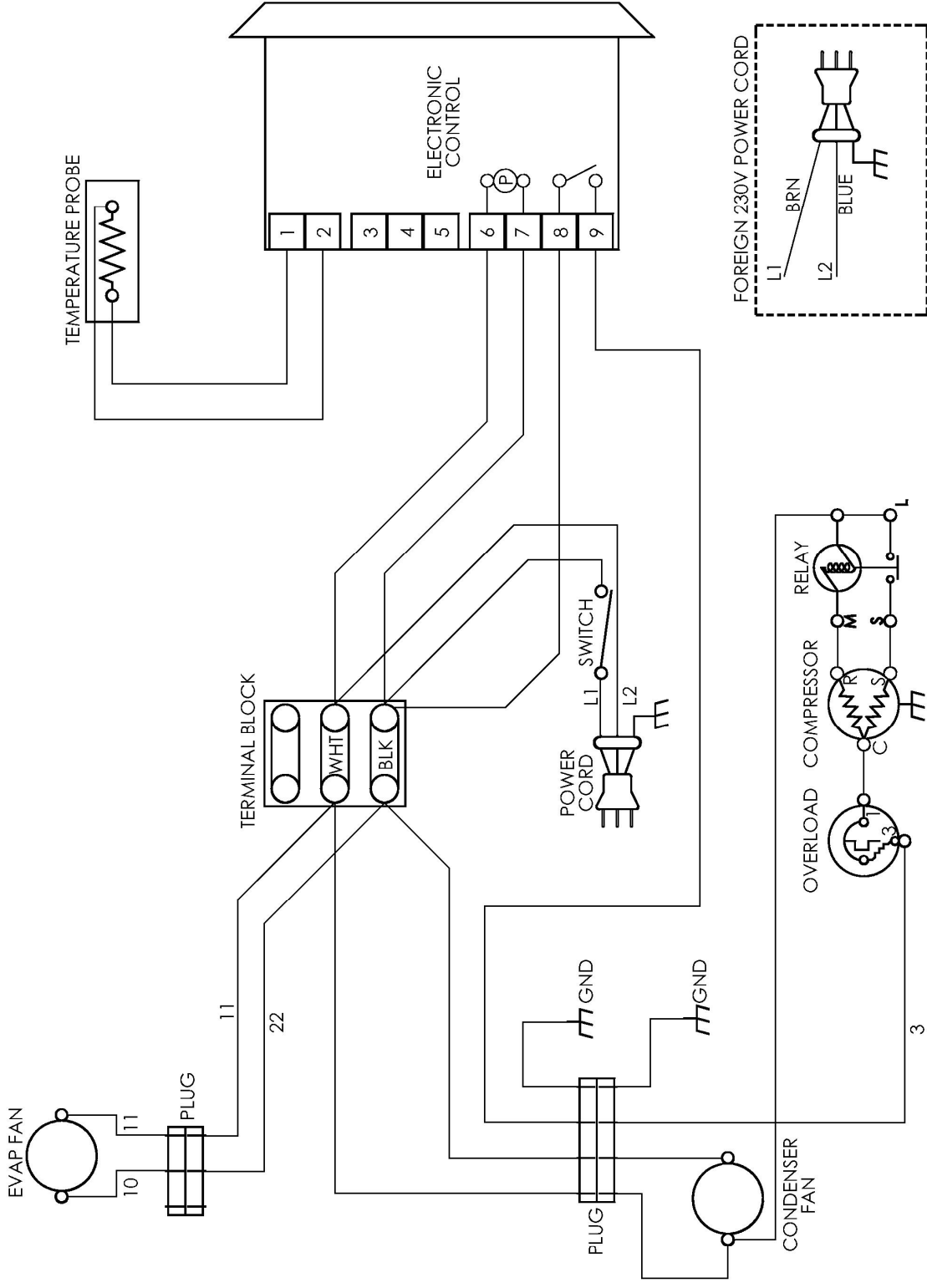

35451 REV. B