

**IMPORTANT FOR FUTURE REFERENCE**

Please complete this information and retain this manual for the life of the equipment:

Model #: \_\_\_\_\_

Serial #: \_\_\_\_\_

Date Purchased: \_\_\_\_\_

## OPERATOR'S MANUAL FOR MODEL 300 RESTAURANT RANGES

**Ranges with Single Oven Base:**

324E,  
336A, 336A-1GL, 336A-2GL, 336A-2TL, 336A-2GR,  
336A-2TR, 336A-3G, 336A-3T  
336D, 336D-1GL, 336D-2GL, 336D-2TL, 336D-2GR,  
336D-2TR, 336D-3G, 336D-3T

**Ranges with Double Oven Base:**

348EE, 348EE-2GL, 348EE-2TL, 348EE-2GR, 348EE-2TR  
360AA, 360AA-2GL, 360AA-2TL, 360AA-2GR, 360AA-2TR,  
360AA-3GL, 360AA-3TL, 360AA-3GR, 360AA-3TR,  
360AD, 360AD-2GL, 360AD-2TL, 360AD-2GR, 360AD-2TR,  
360AD-3GL, 360AD-3TL, 360AD-3GR, 360AD-3TR,  
360DD, 360DD-2GL, 360DD-2TL, 360DD-2GR, 360DD-2TR,  
360DD-3GL, 360DD-3TL, 360DD-3GR, 360DD-3TR

**Ranges with Double Oven Base and Raised Griddle/Broiler:**

360AA-2RR, 360AD-2RR, 360DD-2RR



Model 336D



Model 360AA-2GR

**! WARNING**

Improper installation, adjustment, alteration, service or maintenance can cause property damage, injury or death. Read the installation, operating and maintenance instructions thoroughly before installing or servicing this equipment.

1100 Old Honeycutt Road, Fuquay-Varina, NC 27526  
(919) 552-9161 • FAX (919) 552-9798

# SAFETY PRECAUTIONS

Before installing and operating this equipment, be sure everyone involved in its operation is fully trained and aware of precautions. Accidents and problems can be caused by failure to follow fundamental rules and precautions.

The following symbols, found throughout this manual, alert you to potentially dangerous conditions to the operator, service personnel, or to the equipment.



This symbol warns of immediate hazards which will result in severe injury or death.



This symbol refers to a potential hazard or unsafe practice which could result in injury or death.



This symbol refers to a potential hazard or unsafe practice which could result in injury, product damage, or property damage.



This symbol refers to information that needs special attention or must be fully understood, even though not dangerous.

 **WARNING**  
**FIRE HAZARD**  
**FOR YOUR SAFETY**

Do not store or use gasoline or other flammable vapors and liquids in the vicinity of this or any other appliance.

Keep area around appliances free and clear of combustibles.

Purchaser of equipment must post in a prominent location, detailed instructions to be followed in the event the operator smells gas. Obtain the instructions from the local gas supplier.

 **WARNING**

Asphyxiation can result from improper ventilation. Do not obstruct the flow of combustion and ventilation air to and from your cooking equipment.

**NOTICE**

Be sure this Operator's Manual and important papers are given to the proper authority to retain for future reference.

Congratulations! You have purchased one of the finest pieces of heavy-duty commercial cooking equipment on the market.

You will find that your new equipment, like all Southbend equipment, has been designed and manufactured to meet the toughest standards in the industry. Each piece of Southbend equipment is carefully engineered and designs are verified through laboratory tests and field installations. With proper care and field maintenance, you will experience years of reliable, trouble-free operation. **For best results, read this manual carefully.**

RETAIN THIS MANUAL FOR FUTURE REFERENCE.

## Table of Contents

Specifications .....	4
Installation .....	9
Operation.....	16
Cooking Hints .....	19
Cleaning .....	21
Adjustments.....	24
Troubleshooting.....	31
Parts .....	44

Read these instructions carefully before attempting installation. Installation and initial startup should be performed by a qualified installer. Unless the installation instructions for this product are followed by a qualified service technician (a person experienced in and knowledgeable with the installation of commercial gas an/or electric cooking equipment) then the terms and conditions on the Manufacturer’s Limited Warranty will be rendered void and no warranty of any kind shall apply.

In the event you have questions concerning the installation, use, care, or service of the product, write to:

Technical Service Department  
 Southbend  
 1100 Old Honeycutt Road  
 Fuquay-Varina, North Carolina 27526 USA

Lighting instructions and the serial plate are located on the interior side of the kick panel, as shown below.

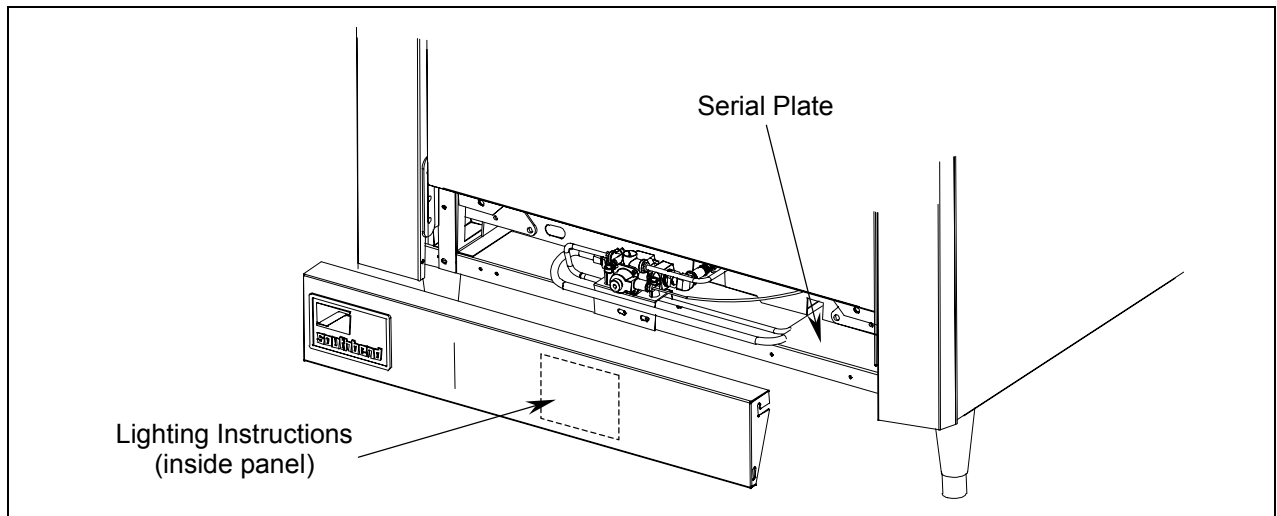



# SPECIFICATIONS

## NOTICE

Local codes regarding installation vary greatly from one area to another. The National Fire Protection Association, Inc. states in its NFPA 96 latest edition that local codes are the "authority having jurisdiction" when it comes to installation requirements for equipment. Therefore, installations should comply with all local codes.

Southbend reserves the right to change specifications and product design without notice. Such revisions do not entitle the buyer to corresponding changes, additions, or replacements for previously purchased equipment.

This product is intended for commercial use only, not for household use.

The installation must conform with local codes, or in the absence of local codes, with the *National Fuel Gas Code, ANSI Z223.1, Natural Gas Installation Code, CAN/CGA-B149.1*, or the *Propane Installation Code CAN/CGA-B149.2*, as applicable, including:

1. The appliance and its individual shutoff valve must be disconnected from the gas supply piping system during any pressure testing of that system at test pressures in excess of 1/2 psi (3.45 kPa).
2. The appliance must be isolated from the gas supply piping system by closing its individual manual shutoff valve during any pressure testing of the gas supply piping system at test pressures equal to or less than 1/2 psi (3.45 kPa).

## GAS SUPPLY

The Serial Plate is located in the compartment below the oven on the right side (on double units - left oven). It indicates the type of gas the unit is equipped to burn. All Southbend equipment is adjusted at the factory. Check type of gas on serial plate.

These models are design-certified for operation on natural or propane gases. For natural gas, the regulator is set to deliver a 4" W.C. pressure to the manifold. For propane gas, it is set to deliver 10" W.C.

If applicable, the vent line from the gas appliance pressure regulator shall be installed to the outdoors in accordance with local codes, or in the absence of local codes, with the *National Fuel Gas Code, ANSI Z223.1, Natural Gas Installation Code, CAN/CGA-B149.1*, or the *Propane Installation Code CAN/CGA-B149.2*, as applicable.

This appliance should be connected ONLY to the type of gas for which it is equipped.

An adequate gas supply is imperative. Undersized or low pressure lines will restrict the volume of gas required for satisfactory performance. Fluctuations of more than 25% on natural gas or 10% on propane gas will create problems and affect burner operating characteristics. A 1/8" pressure tap is located on the manifold to measure the manifold pressure.

An adequate gas supply line to the unit should be no smaller than the inside diameter of the pipe from the unit to which it is connected.

Purge the supply line to clean out dust, dirt, or other foreign matter before connecting the line to the unit.

All pipe joints and connections must be tested thoroughly for gas leaks. Use only soapy water for testing on all gases. NEVER use an open flame to check for gas leaks. All connections must be checked for leaks after the unit has been put into operation. Test pressure should not exceed 14" W.C.

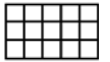

EXTERIOR DIMENSIONS

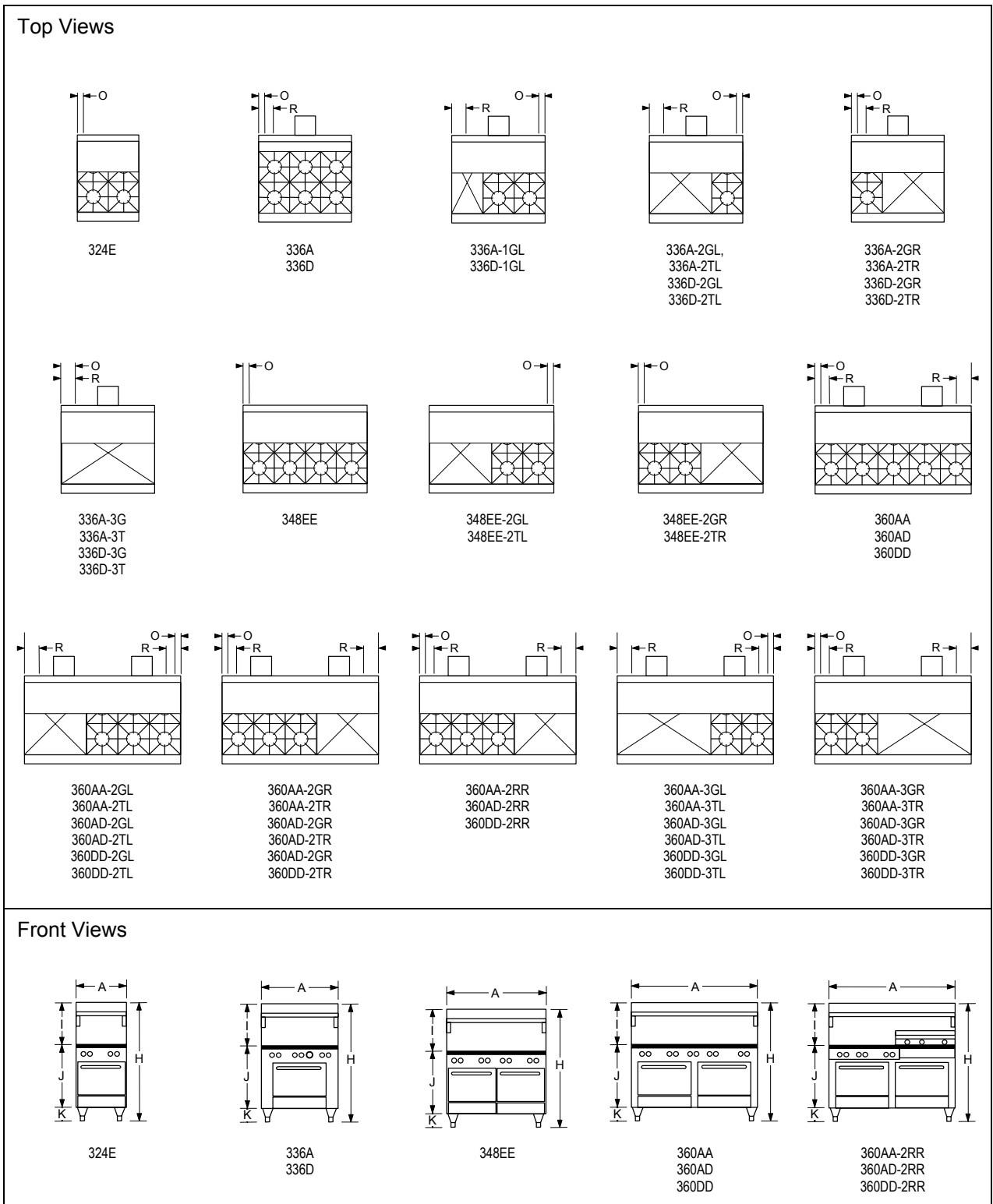
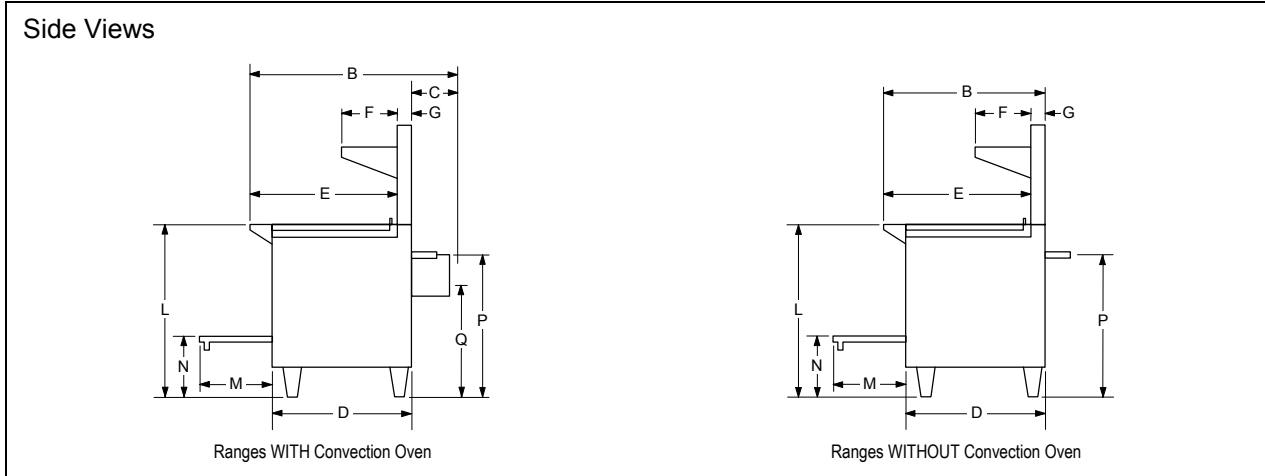

Table continues on next page.



Table continuing from previous page.



Model Number	Exterior Dimensions in Inches and (Millimeters)											Cook Top L	Door Depth M	Oven Bottom N
	A width	B depth	C	D	E	F	G	H	I	J	K			
324E	24.25" (616)	34" (864)	-	29.75" (756)	31" (787)	12" (305)	2.75" (70)	59.5" (1511)	22.5" (572)	31" (787)	6" (152)	37" (940)	15.5" (394)	12.5" (318)
336A	36.5" (928)	42" (1067)	8" (203)	29.75" (756)	31" (787)	12" (305)	2.75" (70)	59.5" (1511)	22.5" (572)	31" (787)	6" (152)	37" (940)	15.5" (394)	12.5" (318)
336D	36.5" (928)	34" (864)	-	29.75" (756)	31" (787)	12" (305)	2.75" (70)	59.5" (1511)	22.5" (572)	31" (787)	6" (152)	37" (940)	15.5" (394)	12.5" (318)
348EE	48.625" (1235)	34" (864)	-	29.75" (756)	31" (787)	12" (305)	2.75" (70)	59.5" (1511)	22.5" (572)	31" (787)	6" (152)	37" (940)	15.5" (394)	12.5" (318)
360AA	60.75" (1544)	42" (1067)	8" (203)	29.75" (756)	31" (787)	12" (305)	2.75" (70)	59.5" (1511)	22.5" (572)	31" (787)	6" (152)	37" (940)	15.5" (394)	12.5" (318)
360AD	60.75" (1544)	42" (1067)	8" (203)	29.75" (756)	31" (787)	12" (305)	2.75" (70)	59.5" (1511)	22.5" (572)	31" (787)	6" (152)	37" (940)	15.5" (394)	12.5" (318)
360DD	60.75" (1544)	34" (864)	-	29.75" (756)	31" (787)	12" (305)	2.75" (70)	59.5" (1511)	22.5" (572)	31" (787)	6" (152)	37" (940)	15.5" (394)	12.5" (318)

Dimension C includes 2" minimum clearance between motor and wall.  
 Raised-griddle surface on Models 360AA-2RR, 360AD-2RR, and 360DD-2RR is 36.5" (927mm) above floor.

### MINIMUM CLEARANCES FROM COMBUSTIBLE CONSTRUCTION



There must be adequate clearance between units and combustible construction. Clearance must also be provided for servicing and for operation.

Minimum Clearances:

	Standard Oven	Convection Oven	Double Oven Base
Sides	6"	8"	8"
Back	6"	8"	6"
Floor	0"	0"	0"

Units are suitable for installation on combustible floors.

Adequate clearance must be provided in the aisle and at the side and rear to allow the door to open sufficiently to permit the removal of the racks and for serviceability.

On units with the convection-type oven, a minimum of 2 inches must be allowed behind the motor and the rear non-combustible enclosure. Care must be taken to provide adequate air circulation to prevent the motor from overheating. No additional clearance from the sides and back is required for service as the units are serviceable from the front.

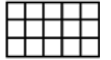

INTERIOR DIMENSIONS AND UTILITY CONNECTION DATA

Model Number	Left (or Only) Oven Interior Dimensions			Right Oven Interior Dimensions			Burners (# and BTU* each)			Total BTU*	Gas Connection Location		Electric Connection Location	
	Width	Depth	Height	Width	Depth	Height	Open	Oven	Griddle		O	P	Q	R
324E	19.5" (660)	26.5" (673)	14" (356)	-	-	-	4 @ 26,000	1 @ 32,000	0	136,000	2.5" (64)	30.25" (768)	-	-
336A	26.125" (664)	24" (610)	14.25" (362)	-	-	-	6 @ 26,000	1 @ 30,000	0	186,000	2.5" (64)	30.25" (768)	24" (610)	6" (152)
336A-1GL 336A-1TL	26.125" (664)	24" (610)	14.25" (362)	-	-	-	4 @ 26,000	1 @ 30,000	1 @ 16,000	150,000	2.5" (64)	30.25" (768)	24" (610)	6" (152)
336A-2GL 336A-2GR 336A-2TL 336A-2TR	26.125" (664)	24" (610)	14.25" (362)	-	-	-	2 @ 26,000	1 @ 30,000	3 @ 16,000	130,000	2.5" (64)	30.25" (768)	24" (610)	6" (152)
336A-3G 336A-3T	26.125" (664)	24" (610)	14.25" (362)	-	-	-	0	1 @ 30,000	4 @ 16,000	94,000	6" (152)	30.25" (768)	24" (610)	6" (152)
336D	26" (660)	26.5" (673)	14" (356)	-	-	-	6 @ 26,000	1 @ 32,000	0	188,000	2.5" (64)	30.25" (768)	-	-
336D-1GL 336D-1TL	26" (660)	26.5" (673)	14" (356)	-	-	-	4 @ 26,000	1 @ 32,000	2 @ 16,000	168,000	2.5" (64)	30.25" (768)	-	-
336D-2GL 336D-2GR 336D-2TL 336D-2TR	26" (660)	26.5" (673)	14" (356)	-	-	-	2 @ 26,000	1 @ 32,000	3 @ 16,000	132,000	2.5" (64)	30.25" (768)	-	-
336D-3G 336D-3T	26" (660)	26.5" (673)	14" (356)	-	-	-	0	1 @ 32,000	4 @ 16,000	96,000	6" (152)	30.25" (768)	-	-
348EE	19.5" (660)	26.5" (673)	14" (356)	19.5" (660)	26.5" (673)	14" (356)	8 @ 26,000	2 @ 32,000	0	272,000	2.5" (64)	30.25" (768)	-	-
348EE -2GL 348EE -2GR 348EE -2TL 348EE -2TR	19.5" (660)	26.5" (673)	14" (356)	19.5" (660)	26.5" (673)	14" (356)	4 @ 26,000	2 @ 32,000	3 @ 16,000	216,000	2.5" (64)	30.25" (768)	-	-
360AA	26.125" (664)	24" (610)	14.25" (362)	26.125" (664)	24" (610)	14.25" (362)	10 @ 26,000	2 @ 30,000	0	320,000	2.5" (64)	30.25" (768)	24" (610)	6" (152)
360AA-2GL 360AA-2GR 360AA-2TL 360AA-2TR	26.125" (664)	24" (610)	14.25" (362)	26.125" (664)	24" (610)	14.25" (362)	6 @ 26,000	2 @ 30,000	3 @ 16,000	264,000	2.5" (64)	30.25" (768)	24" (610)	6" (152)
360AA-3GL 360AA-3GR 360AA-3TL 360AA-3TR	26.125" (664)	24" (610)	14.25" (362)	26.125" (664)	24" (610)	14.25" (362)	4 @ 26,000	2 @ 30,000	4 @ 16,000	228,000	2.5" (64)	30.25" (768)	24" (610)	6" (152)
360AA-2RR	26.125" (664)	24" (610)	14.25" (362)	26.125" (664)	24" (610)	14.25" (362)	6 @ 26,000	2 @ 30,000	2 @ 12,000; 1@9,500	249,500	2.5" (64)	30.25" (768)	24" (610)	6" (152)
360AD	26.125" (664)	24" (610)	14.25" (362)	26" (660)	26.5" (673)	14" (356)	10 @ 26,000	2 @ 32,000	0	324,000	2.5" (64)	30.25" (768)	24" (610)	6" (152)
360AD-2GL 360AD-2GR 360AD-2TL 360AD-2TR	26.125" (664)	24" (610)	14.25" (362)	26" (660)	26.5" (673)	14" (356)	6 @ 26,000	1 @ 32,000	3 @ 16,000	266,000	2.5" (64)	30.25" (768)	24" (610)	6" (152)
360AD-3GL 360AD-3GR 360AD-3TL 360AD-3TR	26.125" (664)	24" (610)	14.25" (362)	26" (660)	26.5" (673)	14" (356)	4 @ 26,000	1 @ 32,000	4 @ 16,000	230,000	2.5" (64)	30.25" (768)	24" (610)	6" (152)
360AD-2RR	26.125" (664)	24" (610)	14.25" (362)	26" (660)	26.5" (673)	14" (356)	6 @ 26,000	1 @ 32,000	2 @ 12,000; 1@9,500	251,500	2.5" (64)	30.25" (768)	24" (610)	6" (152)
360DD	26" (660)	26.5" (673)	14" (356)	26" (660)	26.5" (673)	14" (356)	10 @ 26,000	2 @ 32,000	0	324,000	2.5" (64)	30.25" (768)	24" (610)	6" (152)
360DD-2GL 360DD-2GR 360DD-2TL 360DD-2TR	26" (660)	26.5" (673)	14" (356)	26" (660)	26.5" (673)	14" (356)	6 @ 26,000	2 @ 32,000	3 @ 16,000	268,000	2.5" (64)	30.25" (768)	24" (610)	6" (152)
360DD-3GL 360DD-3GR 360DD-3TL 360DD-3TR	26" (660)	26.5" (673)	14" (356)	26" (660)	26.5" (673)	14" (356)	4 @ 26,000	2 @ 32,000	4 @ 16,000	232,000	2.5" (64)	30.25" (768)	24" (610)	6" (152)
360DD-2RR	26" (660)	26.5" (673)	14" (356)	26" (660)	26.5" (673)	14" (356)	6 @ 26,000	2 @ 32,000	2 @ 12,000; 1@9,500	253,500	2.5" (64)	30.25" (768)	24" (610)	6" (152)

\* BTU values are for natural gas.



## VENTILATION

 **WARNING**

Improper ventilation can result in personal injury or death. Ventilation which fails to properly remove flue products can cause headaches, drowsiness, nausea, or could result in death.

All units must be installed in such a manner that the flow of combustion and ventilation air are not obstructed. Provisions for adequate air supply must be provided. Do not obstruct the front of the unit at the top by the control panel, or the bottom just below the oven compartment, as combustion air enters through these areas.

**NOTICE**

Proper ventilation is the owner's responsibility. Any problem due to improper ventilation will not be covered by the warranty.

All units must be installed in such a manner that the flow of combustion and ventilation air are not obstructed. Provisions for an adequate air supply must be provided. Do not obstruct the front or rear of the unit, as combustion air enters through this area. Be sure to inspect and clean the ventilation system according to the ventilation equipment manufacturer's instructions.

Ranges with solid tops, such as griddles or hot tops, must always have venting for their flue products at the rear of their burner compartments provided by the hollow area inside a shelf 21" high or a backsplash 17" high. Lack of sufficient venting for the burners in these compartments will cause poor burner and pilot operating characteristics, resulting in inefficient performance. Such conditions also cause high ambient temperatures at the manifold area and create valve and thermostat problems.

Canopies are set over ranges, ovens, etc., for ventilation purposes. It is recommended that a canopy extend 6" past the appliance and the bottom edge be located 6'6" from the floor. Filters should be installed at an angle of 45° or more from the horizontal. This position prevents dripping grease and facilitates collecting the run-off grease in a drip pan, unusually installed with a filter. A strong exhaust fan tends to create a vacuum in the room and may interfere with burner performance or may extinguish pilot flames. Fresh air openings approximately equal to the fan area will relieve such a vacuum.

The exhaust fan should be installed at least 2" above the vent opening at the top of the unit.

If the unit is connected directly to an outside flue, a CSA design certified down draft diverter must be installed at the flue outlet of the oven and connected to the flue.

In case of unsatisfactory performance on any appliance, check the appliance with the exhaust fan in the "OFF" position. Do this only long enough to check equipment performance. Then turn hood back on and let it run to remove any exhaust that may have accumulated during the test.

## ELECTRICITY SUPPLY

Units with a convection oven require connection to a supply of electricity. The appliance, when installed, must be electrically grounded in accordance with local codes, or in the absence of local codes, with the *National Electrical Code*, *ANSI/NFPA 70*, or the *Canadian Electrical Code*, *CSA C22.2*, as applicable. An electrical diagram is located on the rear of the range, near the motor.

Usually the range is furnished with one or two power cords (one for each oven), each with a standard 115V 60Hz single-phase prong plug. Total maximum amps for 115V units is 12.5.

The range can be ordered to operate on 208V 60Hz 1-phase or 3-phase current, in which case the electric power supply must be wired to one or two junction boxes (one for each oven), each with a terminal block on the rear of the range. Total maximum amps for 208V units is 8.1.





# INSTALLATION

## NOTICE

These installation procedures must be followed by qualified personnel or warranty will be void.

Local codes regarding installation vary greatly from one area to another. The National Fire Protection Association, Inc. states in its NFPA 96 latest edition that local codes are the "authority having jurisdiction" when it comes to installation requirements for equipment. Therefore, installations should comply with all local codes.

The installation must conform with local codes, or in the absence of local codes, with the *National Fuel Gas Code, ANSI Z223.1, Natural Gas Installation Code, CAN/CGA-B149.1*, or the *Propane Installation Code CAN/CGA-B149.2*, as applicable, including:

1. The appliance and its individual shutoff valve must be disconnected from the gas supply piping system during any pressure testing of that system at test pressures in excess of 1/2 psi (3.45 kPa).
2. The appliance must be isolated from the gas supply piping system by closing its individual manual shutoff valve during any pressure testing of the gas supply piping system at test pressures equal to or less than 1/2 psi (3.45 kPa).

## Step 1: Unpacking

### IMMEDIATELY INSPECT FOR SHIPPING DAMAGE

All containers should be examined for damage before and during unloading. The freight carrier has assumed responsibility for its safe transit and delivery. If damaged equipment is received, either apparent or concealed, a claim must be made with the delivering carrier.

Apparent damage or loss must be noted on the freight bill at the time of delivery. The freight bill must then be signed by the carrier representative (Driver). If the bill is not signed, the carrier may refuse the claim. The carrier can supply the necessary forms.

A request for inspection must be made to the carrier within 15 days if there is concealed damage or loss that is not apparent until after the equipment is uncrated. The carrier should arrange an inspection. Be certain to hold all contents plus all packing material.

1. Cut banding straps and remove corrugated box from range.
2. Cut banding strap holding range to wooden skid.
3. Lift the flue riser off the front of the skid and set it aside.
4. Pull the shelf assembly out from under the base and set it aside.



INSTALLATION

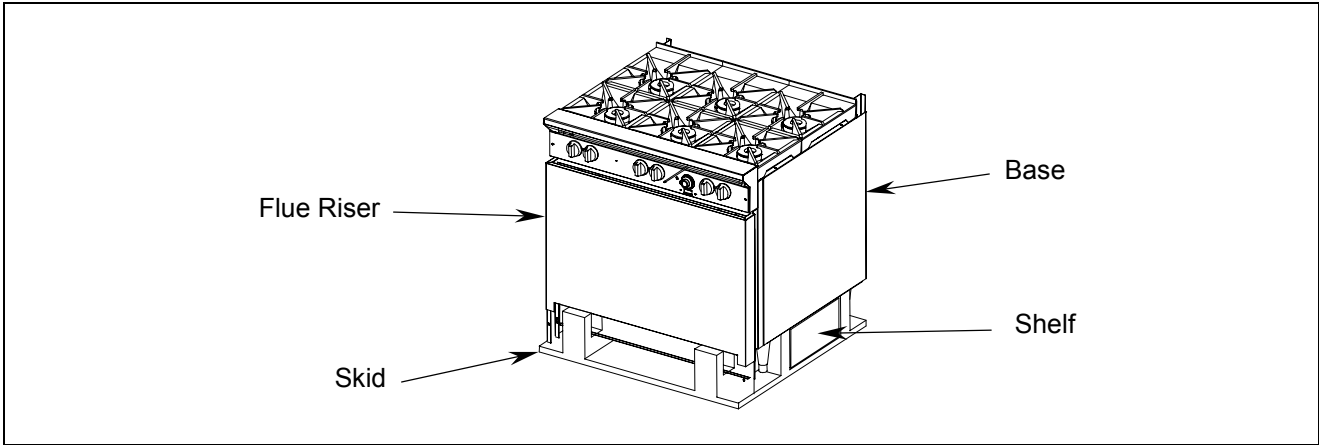

### Step 2a: Install the Legs

A set of four legs is packed with units ordered with legs. (For units ordered with casters, go to Step 2b.)

A threaded leg pad is fastened to the base frame at each corner. Each leg has a corresponding mating thread. The legs can be adjusted to overcome a slightly uneven floor.

1. Raise unit sufficiently to allow leg pads and legs to be attached. For safety, “shore up” and support the unit with an adequate blocking arrangement strong enough to support the load.
2. Attach the four leg pads to the bottom of the range using the lock washers and machine screws. The mounting holes are pre-drilled and threaded.
3. Screw the legs into the holes in the centers of the leg pads.
4. Lower unit gently onto a level surface. Never drop or allow the unit to fall.
5. Use a level to make sure that the range surface is level. The legs can be screwed in or out to lower or raise each corner of the range.
6. Go on to Installation Step 3.

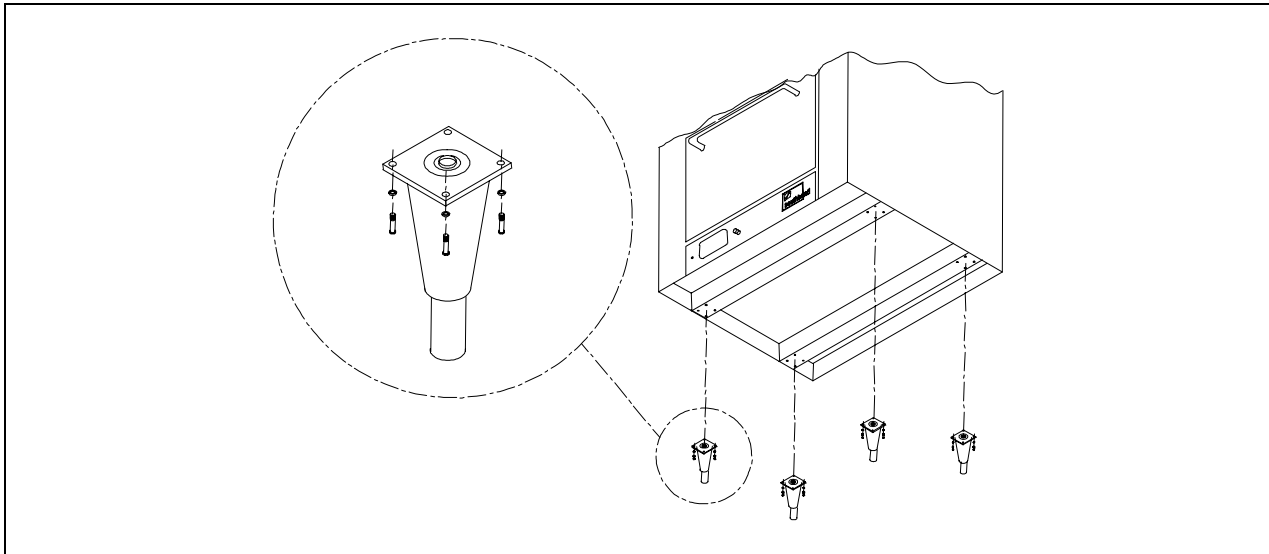



## Step 2b: Install Casters and Restraint

**NOTICE**

For an appliance equipped with casters, (1) the installation shall be made with a connector that complies with the *Standard for Connectors for Movable Gas Appliances, ANSI Z21.69* or *Connectors for Moveable Gas Appliances, CAN/CGA-6.16*, and a quick-disconnect device that complies with the *Standard for Quick-Disconnect Devices for Use With Gas Fuel, ANSI Z21.41*, or *Quick Disconnect Devices for Use with Gas Fuel, CAN1-6.9*, (2) adequate means must be provided to limit the movement of the appliance without depending on the connector and the quick-disconnect device or its associated piping to limit the appliance movement and (3) the restraining means should be attached to a frame member on the back of the unit.

INSTALLATION

A set of four casters is packed with units ordered with casters (instead of legs).

A threaded leg pad is fastened to the base frame at each corner. Each caster has a corresponding mating thread. The casters can be adjusted to overcome a slightly uneven floor. Casters are provided with a Zerk fitting for proper lubrication when required.

1. Raise unit sufficiently to allow leg pads and casters to be attached. For safety, “shore up” and support the unit with an adequate blocking arrangement strong enough to support the load.
2. Attach the four leg pads to the bottom of the range using the lock washers and machine screws. The mounting holes are pre-drilled and threaded.
3. Screw the casters into the holes in the centers of the leg pads. Install the casters that have a locking brake under the front of the unit.
4. Lower unit gently onto a level surface. Never drop or allow the unit to fall.
5. Use a level to make sure that the range surface is level. The casters can be screwed in or out to lower or raise each corner of the range. After the unit has been leveled, tighten the lock nuts.

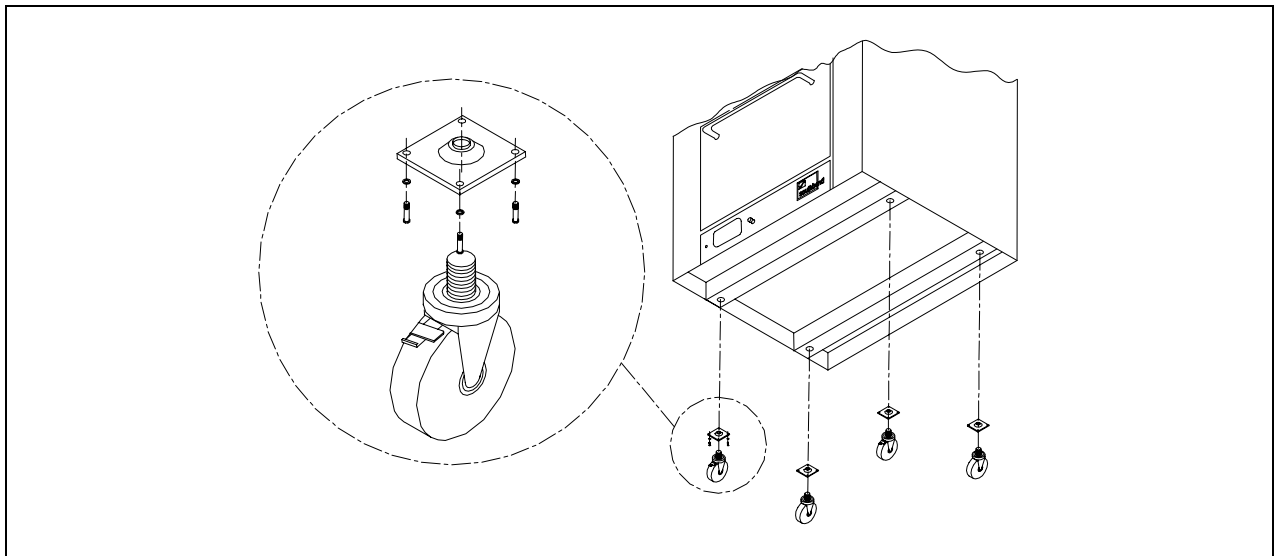

6. Secure the restraining-device bracket (item “B” in the following illustration) to a wall stud located as close as possible to the appliance connector inlet and outlet connections. Use four #12 screws (items “C”) and plastic anchors (items “A”) if necessary.
7. Install eye-bolt (item “F”) to a frame member on the rear of the equipment. After checking carefully behind the frame member for adequate clearance, drill a 1/4” hole through the frame member.



8. Thread hex nut (item "G") and slide the washer (item "H") onto the eye-bolt. Insert the eye-bolt through the 1/4" drilled hole and secure with a washer (item "H") and nylon lock nut (item "I").
9. Using the spring-loaded snap hooks, attach the restraining device to the bracket and the eye-bolt.
10. Using the cable clamp (item "D"), adjust the restraining device extended length to prevent over-bending or kinking of the appliance connector.

INSTALLATION

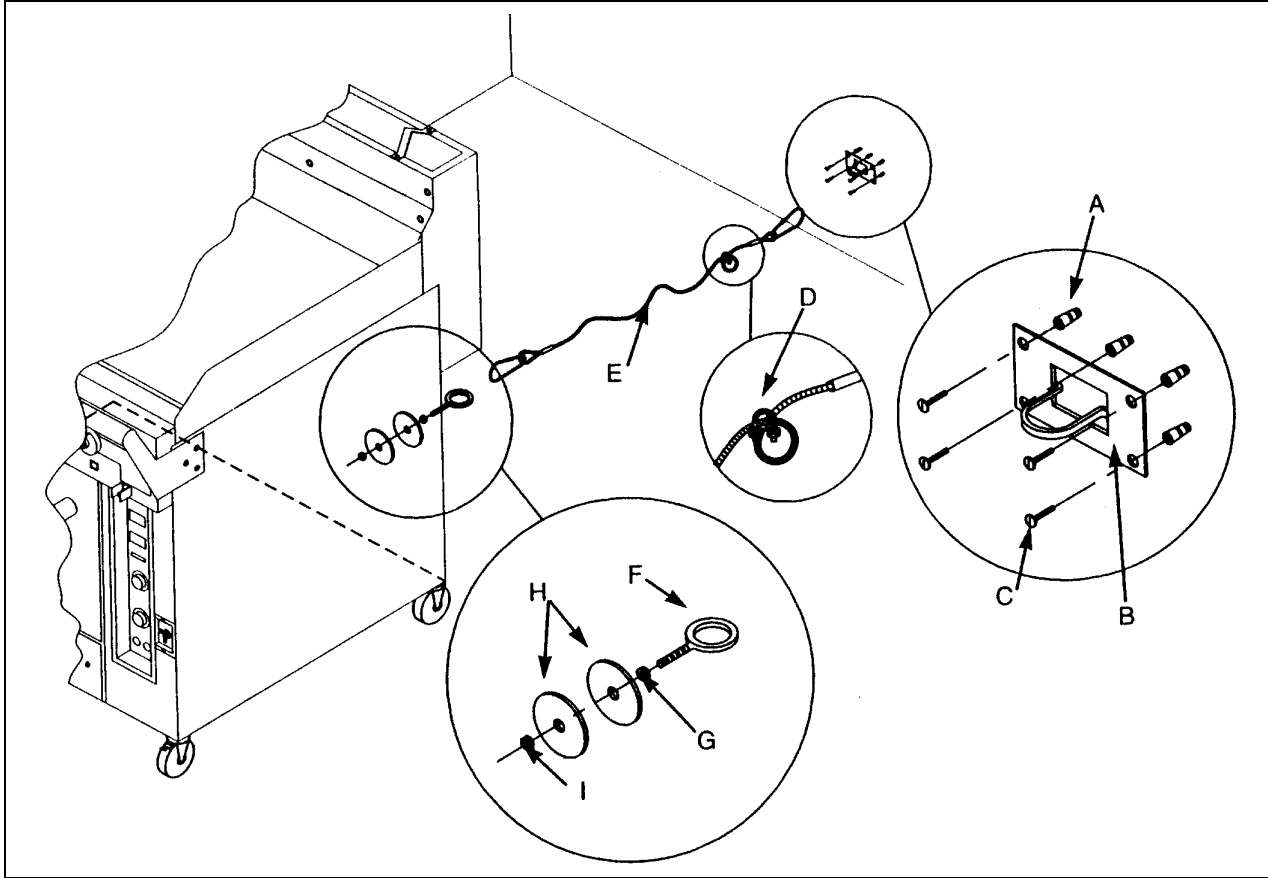

For units not equipped with flame safety devices, be sure all valves are turned off prior to disconnecting. After reconnecting, be sure all valves are turned off and all pilots are lit.

### NOTICE

Adequate means must be provided to limit the movement of the appliance without depending on the connector and the quick-disconnect device or its associated piping to limit the appliance movement.

The restraining means should be attached to a frame member on the back of the unit.



### Step 3: Attach Flue Riser and Shelf Assemblies

1. Place the flue riser assembly on the range as shown on the appropriate diagram below.
2. Slide the flue riser assembly over the bayonets until it bottoms out, as shown below.
3. Secure ends of flue riser assembly with two (2) 1/4-20 x 3/4 hex head bolts, flat washers and lockwashers
4. Attach the shelf assembly to the flue riser assembly.

#### Single-Oven Models

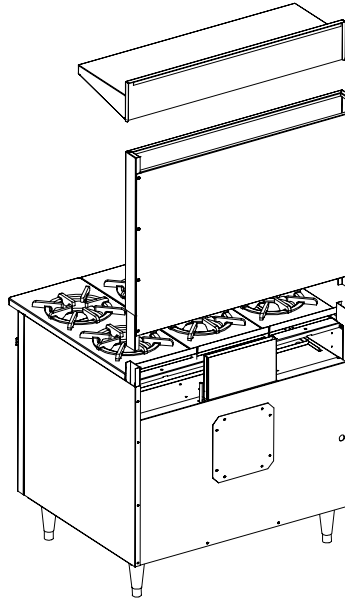

#### Dual-Oven Models

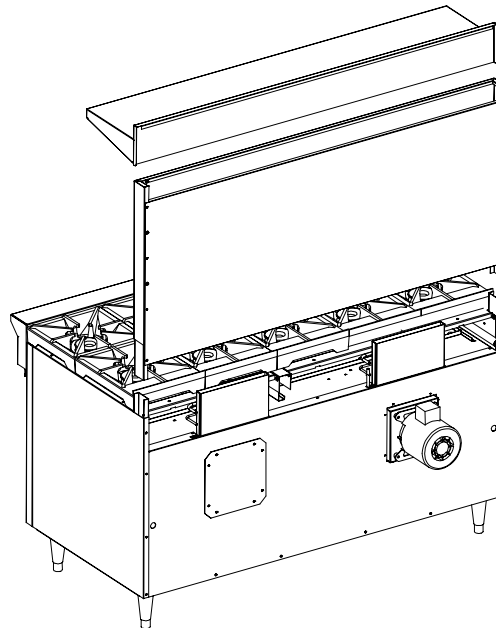



## Step 4: Connect Electricity (for Models with Convection Ovens)

Wiring diagrams are located on the rear of the range. Be sure that the input voltage and phase match the requirements shown on the serial plate.

Ranges ordered with a **115V, 60Hz, single-phase** electrical rating are factory-supplied with one or two three-wire cords (one for each oven), each with a three-prong plug that fits any standard three-prong grounded receptacle. Single-oven units require a 15 ampere supply, while double-oven units require a 20 ampere supply.

Ranges ordered with a **208/236V, 60Hz, single- or three-phase** electrical rating are factory-equipped with one or two two-pole terminal blocks (one for each oven), located behind cover plate(s) located on the rear of the unit. To connect the supply wires, remove the appropriate cover plate. Route the supply wires and the grounding wire through the strain relief fitting to the terminal block. Insert the supply wires, one each, into the two poles of the terminal block and tighten the screws. Insert the ground wire into the grounding lug and tighten the screw. Re-attach the cover plate.

Three phase units are wired as above, using only two supply wires. The third wire is not used and must be properly terminated.

All units are shipped wired as specified by factory order. Conversion between single-phase and three-phase can be accomplished by referring to phase loading and line amperes chart on wiring diagram for wire size and ampere requirements.

## Step 5: Connect Gas Supply

If this equipment is being installed at over 2,000 feet altitude and that information was not specified when ordered, contact the appropriate authorized Southbend Service Representative or the Southbend Service Department. Failure to install with proper orifice sizing will result in poor performance and may void the warranty.

The Serial Plate is located in the compartment below the oven on the right side (on double units - left oven). It indicates the type of gas the unit is equipped to burn. All Southbend equipment is adjusted at the factory. Check type of gas on serial plate.

These models are design-certified for operation on natural or propane gases. For natural gas, the regulator is set to deliver a 4" W.C. pressure to the manifold. For propane gas, it is set to deliver 10" W.C.

This appliance should be connected **ONLY** to the type of gas for which it is equipped.

An adequate gas supply is imperative. Undersized or low pressure lines will restrict the volume of gas required for satisfactory performance. Fluctuations of more than 25% on natural gas or 10% on propane gas will create problems and affect burner operating characteristics. A 1/8" pressure tap is located on the manifold to measure the manifold pressure.

An adequate gas supply line to the unit should be no smaller than the I.D. of the pipe from the unit to which it is connected.

Purge the supply line to clean out dust, dirt, or other foreign matter before connecting the line to the unit.

### CAUTION

ALL PIPE JOINTS AND CONNECTIONS MUST BE TESTED THOROUGHLY FOR GAS LEAKS. USE ONLY SOAPY WATER FOR TESTING ON ALL GASES. NEVER USE AN OPEN FLAME TO CHECK FOR GAS LEAKS. ALL CONNECTIONS MUST BE CHECKED FOR LEAKS AFTER THE UNIT HAS BEEN PUT INTO OPERATION. TEST PRESSURE SHOULD NOT EXCEED 14" W.C.



### Step 6: Check the Installation

1. Check that all screws and bolts are tightened.
2. Move the range into the position at which it will be operated.
3. Check that the range is level. If not, adjust the legs.
4. Check that the appropriate clearances are satisfied (see page 6).

### Step 7: Adjust Air Shutters and Pilot Heights

All units are adjusted at the factory. However, burner air shutters and pilot heights should be checked at installation and adjusted if necessary. On new installations, start with the top burner of the unit(s) furthest from the gas input to the manifold. This will purge the system of air. Turn main gas supply "ON".

### Step 8: Condition Griddle Surfaces

New griddles should be carefully tempered and cared for in order to avoid possible damage. To break in a new griddle, first wipe it clean. Next, light all the griddle burners and turn them to low for one hour. Then gradually bring each griddle up to frying temperature. Next, spread three or four ounces of beef suet, or as a substitute, baking soda, to season it. Never allow water on a hot griddle and never wash it with soap and water.



# OPERATION

 **DANGER**  
**EXPLOSION HAZARD**

In the event a gas odor is detected, shut down equipment at the main shut off valve. Immediately call the emergency phone number of your gas supplier.

 **CAUTION**

To eliminate gas build up which could result in an explosion, in the event of main burner ignition failure a five minute purge period must be observed prior to re-establishing ignition source.

 **CAUTION**

Top section pilots, when out, do not interrupt the flow of gas to the burners. Consequently, it is the responsibility of the operator to check the ignition of the burners, immediately after burner valve has been turned "ON". Should ignition fail after 10 seconds, turn off burners, wait 5 minutes, and then try again.

OPERATION

## LIGHTING AFTER GAS HAS BEEN SHUT OFF

When turning the main gas supply on after the gas supply has been shut off, do the following:

1. Make sure all of the control valves are in the "OFF" position.
2. Turn on the gas supply.
3. Light the pilots as described below.
4. Light oven first and then wait six minutes before lighting top section. This allows all air to be purged from the range.

## OPEN-TOP BURNER SECTIONS

Each open-top burner is controlled by a knob on the front control panel.

To light the pilots of an open-top burner section, do the following:

1. Turn all gas valves to the "OFF" position.
2. Check to make sure pilots are in the correct position.
3. Light the pilots.
4. Adjust the pilot flame as necessary.





## HOT TOP SECTIONS

Range can be ordered with a hot-top section replacing one or more open-top burner sections. Each hot-top is controlled by a knob on the front control panel.

To light the pilots of a hot-top section, do the following:

1. Raise or remove hot-top plate. Every two burners have one pilot located at the front and in between burners.
2. Light the pilot.
3. Pilot flame should be steady blue, large enough to effect ignition.
3. Turn burner valve completely on. The sharp blue flame should be approximately 1/4" to 3/8" high.
5. Replace hot top plate.

## NON-THERMOSTATIC GRIDDLE SECTIONS

Ranges can be ordered with thermostatic or non-thermostatic griddle sections. Each griddle is controlled by a knob on the front control panel.

At the end of each use, allow griddle to cool normally. After griddle has cooled, coat griddle surface with a light film of cooking oil to protect surface from moisture.

To light the pilots of a non-thermostatic griddle section, do the following:

1. Raise griddle at front so it is approximately 8" high and block it with two (2) two-by-fours.
2. Ignite pilot tube located under all burners with port at each side of burners. Pilots are supplied and adjusted by a common valve located below the filter on the manifold.
3. Burners should have 1/2" to 5/8" steady blue flame. Adjust if necessary.
4. Lower griddle into position and observe burner operating characteristics through holes in valve panel.

## THERMOSTATIC GRIDDLES

Ranges can be ordered with thermostatic or non-thermostatic griddle sections. Each griddle is controlled by a knob on the front control panel.

At the end of each use, allow griddle to cool normally. After griddle has cooled, coat griddle surface with a light film of cooking oil to protect surface from moisture.

To light the pilots of a thermostatic griddle section, do the following:

1. Raise griddle at front so it is approximately 8" high and block it with two (2) two-by-fours.
2. The sensing bulbs must be fully inserted into their tubular holders, which are welded to the underside of the griddle.
3. One pilot tube is located under all burners with ports at each side of the burners. Pilots are supplied and adjusted by a common valve on the manifold. Ignite pilots.
4. Set thermostat dials to maximum, one at a time.
5. Burners should have 1/2" to 5/8" steady blue flame. Adjust if necessary.
6. Lower griddle carefully into position taking extreme care that capillary tubes are coiled under manifold in valve panel compartment. NEVER leave any part of the capillary tube in the burner compartment.
7. Observe burner flame through holes in valve panel, turn thermostat dial at maximum for ten minutes, then turn dial to "LOW" and adjust bypass on thermostat so there is a 1/8" minimum and 1/4" maximum flame at each port.



## RAISED-GRIDDLE BROILER SECTION

Ranges can be ordered with a raised-griddle broiler section. Each raised-griddle broiler is controlled by a knob on the front control panel.

At the end of each use, allow griddle to cool normally. After griddle has cooled, coat griddle surface with a light film of cooking oil to protect surface from moisture.

To light the pilots of a raised-griddle broiler, do the following:

1. Remove griddle from unit.
2. Position ceramics on burners with projections pointing downward.
3. Light pilot tube ports (2 at each burner). Adjust pilot flame to be large enough to effect ignition.
4. Place griddle in position on range.
5. Turn valves completely on.
6. Burner should have 1/2" to 5/8" steady blue flame. Adjust if necessary.

## SHUTDOWN OF ENTIRE RANGE

To place the range in a standby state (ready for use), do the following:

1. Turn all manual gas valves "OFF."
2. Turn all thermostats to their lowest position.

To completely shut down the range for an extended period (or prior to disconnecting the gas supply), do the following:

1. Turn all manual gas valves and pilots "OFF."
2. Turn all thermostats to their lowest position.
3. Turn main supply gas valve "OFF."

## OVENS

Ranges can be ordered with standard or convection ovens. Each oven is controlled by a knob on the front control panel.

To light the pilot of an oven, do the following:

1. Turn oven thermostat to "OFF" position.
2. For convection ovens, turn the fan switch to the "OFF" position.
3. Open door, remove oven bottom and fire plate to expose pilot and burner.
4. Open kick panel and depress red button on oven safety valve.
5. Light constant pilot (the pilot without capillary tube holder).
6. Replace fire plate and oven bottom.
7. Turn thermostat to desired temperature.

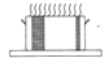

# COOKING HINTS

## COOKING TIPS (Convection-Type Oven Only)

- A. FROZEN ENTREE PRODUCTS:** Punch holes in lid before heating. Tent lid if product has a tendency to stick, i.e., lasagna or macaroni and cheese. Use manufacturer's convection oven directions for time and temperature or reduce conventional oven temperature 50 degrees for a 6-1/2 size pan load. Some products may cook in 10 to 15 minutes less time than recommended for convection ovens if prepared from frozen in a 6 pan load.
- B. FRUIT PIES:** Use temperature and time from manufacturer's directions for convection ovens for a 12 pie load placed on 3 bun pans.
- C. ROLLS – YEAST:** Use temperature and time recommended by manufacturer for convection ovens for a 3 pan load.
- D. POTATOES – PRE-BLANCHED, FROZEN:** Spread on ungreased bun pans, 3 pans per load. Bake at 400°F, stirring once, for 15 to 18 minutes.
- E. FISH PORTIONS – BREADED, PRE-COOKED:** Use manufacturer's recommended temperature and time for convection oven for a 3 pan load.
- F. POTATOES – BAKING, 8 OZ. SIZE:** Wash and wrap in potato foil. Place 30 potatoes on 18 x 24 bun pan — 3 pans per load. Bake in 400°F oven for 1 hour.
- G. TOP ROUND OF BEEF, NO. 168:** Set oven at 250°F. Place trimmed roast on pan. For 14 - 16 pounds:
  - 140° rare - 14 minutes/pound
  - 150° medium - 16 minutes/pound
  - 160° well done - 17-1/2 minutes/pound.

COOKING HINTS

## COOKING SUGGESTIONS (Convection-Type Oven Only)

If...	then...
Cakes are dark on the sides and not done in the center...	lower oven temperature.
Cake edges are too brown...	reduce number of pans or lower oven temperature.
Cakes have light outer color...	raise temperature.
Cake settles slightly in the center...	bake longer or raise oven temperature slightly. Do not open doors too often for long periods.
Pies have uneven color...	reduce number of pies per rack.
Meats are browned and not done in center...	lower oven temperature and roast longer.
Meats are well done and not browned...	raise temperature. Limit amount of moisture.
Cakes ripple...	overloading pans or batter is too thin.
There is excessive meat shrinkage...	lower oven temperature.
Cakes are too coarse...	lower oven temperature.



## GUIDE TO BAKING TIMES AND TEMPERATURES (Convection-Type Oven Only)

As a guide, set oven temperatures 25 to 50 degrees lower than called for in recipes using non-convection ovens, i.e., range or conventional ovens.

Time and temperatures will vary depending upon load, mix, size or portion and other factor. Use this chart to develop your own cooking techniques:

COOKING HINTS

Product	Timing (minutes)	Temperature Setting	Number of Racks Used	Count per Pan/Rack
Hamburger buns, 3 oz. - 4"	18	375°	3	24
Yeast rolls - 1 oz.	10	400°	3	48
Fruit pies, 46 oz. frozen	50	375°	3	4
Egg custard pies, 44 oz. frozen	60	325°	3	4
Dutch apple pies, 46 oz. frozen	50	350°	3	4
Baked potatoes, 8 oz.	60	400°	3	30 (wrapped)
Pre-blanching potatoes, frozen	16	400°	3	5 lb.
Fish portions, pre-cooked, breaded, 3 oz.	16	400°	3	32
Macaroni & cheese, 6 lbs. - 40° temp.	45	400°	3	2-6 lbs.
Lasagna w/meat sauce, 6 lb. - 40° temp.	60	350°	3	2 - 6 lbs.
Lasagna w/meat sauce, 6 lb. - frozen	75	350°	3	2-6 lbs.
Salisbury steak w/gravy, 6 lb. - 40° temp.	45	400°	3	2-6 lbs.
Top round of beef No. 168				
14 lb. - rare	140° internal 14 min./lb.	250°	1	1 - 2
14 lb. - medium	150° internal 14 min./lb.	250°	1	1 - 2
14 lb. - well done	160° internal 14 min./lb.	250°	1	1 - 2

### **WARNING**

THE USE OF ALUMINUM FOIL CAN CAUSE HEAT DISTRIBUTION PROBLEMS IN OVENS. EXTREME CARE MUST BE USED WHEN PLACING ALUMINUM FOIL IN THE OVEN TO ENSURE THAT IT DOES NOT BLOCK OR CHANGE THE AIR FLOW. THE USE OF ALUMINUM FOIL MAY VOID THE PRODUCT WARRANTY IF ITS USE IS ASCERTAINED TO BE A PROBLEM.



# CLEANING

Southbend equipment is sturdily constructed of the best materials and is designed to provide durable service when treated with ordinary care. To expect the best performance, your equipment must be maintained in good condition and cleaned daily. Naturally, the periods for this care and cleaning depend on the amount and degree of usage.

## EXTERIOR AND TOP SECTIONS:

Keep exposed, cleanable areas of unit clean at all times.

### Daily:

- A. Remove, empty, and clean grease drawers and dirt trays.
- B. Clean griddle drain chutes.

### Monthly:

- A. Clean around burner air mixers and orifices if lint has accumulated.
- B. Visually assure proper pilot operation.

## VENT SYSTEM

At least twice a year the unit venting system should be examined and cleaned.

*Following daily and periodic maintenance procedures will enhance long life for your equipment. Climatic conditions (such as salt air) may require more thorough and frequent cleaning or the life of the equipment could be adversely affected.*

## STAINLESS STEEL SURFACES

1. To remove normal dirt, grease and product residue from stainless steel that operates at LOW temperature, use ordinary soap and water (with or without detergent) applied with a sponge or cloth. Dry thoroughly with a clean cloth.
2. To remove grease and food splatter, or condensed vapors, that have BAKED on the equipment, apply cleanser to a damp cloth or sponge and rub cleanser on the metal in the direction of the polishing lines on the metal. Rubbing cleanser, as gently as possible, in the direction of the polished lines will not mar the finish of the stainless steel. NEVER RUB WITH A CIRCULAR MOTION. Soil and burnt deposits which do not respond to the above procedure can usually be removed by rubbing the surface with SCOTCH-BRITE scouring pads or STAINLESS scouring pads. DO NOT USE ORDINARY STEEL WOOL, as any particles left on the surface will rust and further spoil the appearance of the finish. NEVER USE A WIRE BRUSH, STEEL SCOURING PADS (EXCEPT STAINLESS), SCRAPER, FILE OR OTHER STEEL TOOLS. Surfaces which are marred collect dirt more rapidly and become more difficult to clean. Marring also increases the possibility of corrosive attack. Refinishing may then be required.
3. **To remove heat tint** – Darkened areas sometimes appear on stainless steel surfaces where the area has been subjected to excessive heat. These darkened areas are caused by thickening of the protective surface of the stainless steel and are not harmful. Heat tint can normally be removed by the foregoing, but tint which does not respond to this procedure calls for a vigorous scouring in the direction of the polish lines, using SCOTCH-BRITE scouring pads or a STAINLESS scouring pad in combination with a powered cleanser. Heat tint action may be lessened by not applying, or by reducing heat to equipment during slack periods.



## BLACK BAKED ENAMEL SURFACES

Allow unit to cool somewhat after use and wash exterior with a hot, mild detergent or soap solution; particularly clean off all grease deposits. Dry thoroughly with a dry cloth.

## BURNERS – GENERAL

Little attention is needed, but if spillage should occur, it may be necessary to clean around pilot areas, air mixer and under burners. Use a wire brush if necessary.

Periodically, burners (particularly open top type) should be removed and cleaned. Allow interior to drain. Dry thoroughly before replacing.

## HOT TOPS

Allow range to cool. If water is used on tops while still hot, they may crack. Avoid this practice. Remove tops from range and clean surfaces with hot water and detergent. A wire brush may be used on the underside of the hot top plate. It is recommended not to clean tops while still on range, even if cooled, as excessive water will drip into the burner box and deteriorate the metal.

Do not waste gas and abuse equipment by leaving all burners "Full On," if not required. During idling periods, adjust burner valves to keep top warm. Re-adjust burner valves as required for periods of heavy loads.

## CARE OF GRIDDLES

New griddles should be carefully tempered and cared for in order to avoid possible damage. To break in a new griddle, first wipe it clean. Next, light all the griddle burners and turn them to low for one hour. Then gradually bring each griddle up to frying temperature. Next, spread three or four ounces of beef suet, or as a substitute, baking soda, to season it. Never allow water on a hot griddle and never wash it with soap and water.

Use a Norton Alundum Griddle Brick to clean the griddle. Always remember to heat griddle slowly because quick heat may cause costly damage. Griddle plates cannot be guaranteed against damage due to carelessness. Never place utensils on griddle. Do not overheat griddle above 550°F, as this will cause warpage or breakage.

Do not use any type of steel wool. Small particles may be left on the surface and get into food products. Do not clean spatula by hitting the edge on the griddle plate. Such action will only cut and pit the griddle plate, leaving it rough and hard to clean.

Do not waste gas or abuse equipment by leaving valves at "Full On" position or thermostat at a high temperature if not required. During idle periods, set valves at "Low" position or thermostats to low temperature settings to keep griddle warm. Reset valves or thermostats, as required, for periods of heavy load. Turn valves or thermostats to "OFF" at end of daily operation.

## OPEN TOP PLATE

Remove enameled top plate and spiders, clean with a solution of hot water and strong soap or detergent.

The area around the charge port, where the flash tube is attached to the burner, must be free from any spillage or residue, or other obstructions.

The flash tubes must be clean and properly aligned with the pilot housing to insure good top burner ignition. Pilot should be 1/2" to 5/8" blue flame. Avoid carbon producing tip or unstable blowing or lifting of flame.



### OVEN INTERIOR (STANDARD-TYPE OVEN)

Allow oven to cool. Remove porcelain enameled oven bottom. Clean by rubbing with strong detergent and Brillo pad or similar scrubber. "Spill-overs" should be cleaned from the bottom as soon as possible to prevent carbonizing and a "burnt-on" condition. For stubborn accumulations, commercial oven cleaners are recommended.

The porcelain oven door lining can be cleaned in a similar manner.

The side, rear and top lining should be wiped only with a cloth dampened with a mild detergent and water. Avoid using excessive amounts of water, as this may drip into burner compartment and deteriorate the metal in that area. Do not use strong commercial cleaners or abrasive pads on the side, rear or top linings, as they may damage the finish or leave gray residue.

### OVEN INTERIOR (CONVECTION-TYPE OVEN)

 **WARNING**

FOR YOUR SAFETY, DISCONNECT THE POWER SUPPLY TO THE APPLIANCE BEFORE CLEANING.

WHEN CLEANING THE BLOWER WHEEL, BE SURE TO HAVE THE POWER SWITCH IN THE "OFF" POSITION.

Allow oven to cool. Remove porcelain enameled oven bottom. Clean by rubbing with strong detergent and Brillo pad or similar scrubber. "Spill-overs" should be cleaned from the bottom as soon as possible to prevent carbonizing and a "burnt-on" condition. For stubborn accumulations, commercial oven cleaners are recommended.

The porcelain oven door lining can be cleaned in a similar manner.

The side, rear and top lining should be wiped only with a cloth dampened with a mild detergent and water. Avoid using excessive amounts of water, as this may drip into burner compartment and deteriorate the metal in that area. Do not use strong commercial cleaners or abrasive pads on the side, rear or top linings, as they may damage the finish or leave gray residue.



# ADJUSTMENTS

## **WARNING**

ADJUSTMENTS AND SERVICE WORK MAY BE PERFORMED ONLY BY A QUALIFIED TECHNICIAN WHO IS EXPERIENCED IN, AND KNOWLEDGEABLE WITH, THE OPERATION OF COMMERCIAL COOKING EQUIPMENT. HOWEVER, TO ASSURE YOUR CONFIDENCE, CONTACT YOUR AUTHORIZED SERVICE AGENCY FOR RELIABLE SERVICE, DEPENDABLE ADVICE OR OTHER ASSISTANCE, AND FOR GENUINE FACTORY PARTS.

In case of problems in operation at initial installation, check type of gas and manifold pressure and compare with information listed on the serial plate.

### GAS PRESSURE REGULATOR

The pressure regulator is factory set at 4" W.C. for natural gas and 10" W.C. for propane gas. To check the manifold pressure:

1. Turn all thermostats and burner valves to "OFF" position.
2. Turn main gas valve to entire unit off.
3. Remove valve panels and locate 1/8" plug in manifold.
4. Remove plug and install a fitting appropriate to connect a manometer.
5. Turn on main gas to unit and light pilots.
6. Turn all burners and ovens to full "ON" position and read manometer.
7. If manometer does not read 4" W.C. for natural gas, or 10" W.C. for propane gas, adjust regulator (if gas pressure is O.K. go to Step 10).
8. Remove cap from top of regulator.
9. With a screwdriver rotate regulator adjustment screw "clockwise" to increase, or "counterclockwise" to decrease, pressure until manometer shows correct reading.
10. Repeat steps 1 and 2.
11. Remove manometer fitting and replace plug in manifold.
12. Repeat step 5.
13. Replace valve panels.

ADJUSTMENTS

### TOP PILOTS: NON-AERATED (YELLOW-TIPPED FLAME) TYPE

These are located under fry-tops, hot-tops, broiler-griddles and on the flash tube system of open top grate burners.

Outage is often caused by an unstable flame due to over-adjustment to the point where the flame is leaving its port, or "blowing off."

Often, in an effort to improve ignition, the pilots are increased too much and result in this unstable condition.

These pilots are adjusted by inserting the blade of a screwdriver into the slot on the small valve, located on the manifold. The maximum flame size is approximately 3/4" with a slight yellow tip. The first indication of over-adjustment is evident when the yellow tip begins to stream into black streaks and generate carbon. Continued over-adjustment leads to the unstable lifting and blowing condition.





## ALL TOP BURNERS

All burners have a primary air adjustment by means of an air shutter on the mixer face.

Loosen screw and rotate mixer cap until a clear, stable blue flame is obtained. The flame should not be yellow tipped nor should it blow off the burner ports.

All orifice sizes and burner rate are properly set at the factory and should not be altered.

Over-rated burners cause poor burner and pilot performance, resulting in less heat, and wasted gas.

Over-gassed burners DO NOT heat the hot-top or griddle as efficiently as those that are properly adjusted. Such conditions also create “hot spots” on griddles. Floating and unstable burner and pilot flames will result when solid tops are lowered into position because the rear openings of the burner compartment are not adequate to vent the enormous flue products generated by over-gassed burners. The “unburned” gas will ignite at the rear and burn in this section and even up inside the backguard or shelf venting system, causing structural members in this area to deteriorate. Also, some of these hot flue products will vent forward into the manifold compartment resulting in problems with valves and thermostats due to overheating. AGAIN, over-rated burners waste energy and cause service problems.

## OVEN STANDING PILOT

The standing oven pilot flame can be adjusted by turning the adjusting screw on the pilot line valve with a screwdriver. The pilot line valve is located behind the front panel below the oven door. Remove the front panel to gain accessibility. The pilot flame is properly adjusted when it is just large enough to maintain a glowing red color of the flame switch capillary bulb.

## OVEN BURNER FLAME

The oven burner orifice is of the fixed type, sized for the respective gas supply. The burner flame characteristics are controlled by varying the primary air mixer cap. There should be a clear blue flame with a distinct inner cone at each port. Excessive primary air can result in “blowing” or the flames leaving the ports. Lack of primary air causes soft or yellow tipped flame.

## OVEN BY-PASS FLAME LEVEL

When the oven reaches the temperature at which the dial is set, the oven control cuts down the flow of gas to the amount required to keep the oven at that temperature. Always, however, the control must by-pass enough gas to keep the entire burner lighted. To maintain this minimum flame, *the by-pass must be set carefully and accurately*, as follows (see illustration on page 26):

1. Light the oven burner, then turn dial to “Broil.”
2. After 5 minutes, turn dial clockwise to point slightly beyond first mark on dial.
3. Remove dial and bezel.
4. With a screwdriver, turn by-pass Adjustor (counterclockwise to increase the flame, clockwise to decrease it) until there is a flame approximately 1/8" high over the entire burner.
5. Replace bezel and dial, turning the dial clockwise until it locks in the “Off” position.

## OVEN THERMOSTAT CALIBRATION

The oven control is carefully calibrated at the factory—that is, it is so adjusted that dial settings match actual oven temperatures. Field recalibration is seldom necessary, and should not be resorted to unless considerable experience with cooking results definitely proves that the control is not maintaining the temperatures to which the dial is set.

Recalibration should not be undertaken, however, until the oven by-pass flame has been adjusted.



To check oven temperatures when recalibrating, use a test instrument or a reliable mercury thermometer. Place the thermocouple of test instrument or the thermometer in the middle of the oven.

Proceed as follows:

1. Remove dial and push out metal insert (see illustration below).
2. Replace dial, turn to 400 mark, and light oven burner.
3. After burner has been on about 15 minutes check oven temperature. Oven door should be open for as short a time as possible. Use a flashlight, if necessary, to see the thermometer clearly.
4. Continue to check temperature, at 5-minute intervals, until two successive readings are within 5 degrees of each other.

The control should be recalibrated if your reading is not within 20 degrees of the dial setting (400 degrees). If calibration is required, the additional steps to be taken are these:

5. Hold dial firmly, insert screwdriver through center of dial, and push calibration stem inward (see illustration below). **DO NOT TURN THIS STEM.**
6. While holding calibration stem in firmly with screwdriver, turn dial until it is set at the actual oven temperature as shown by your test instrument or thermometer. Release pressure on calibration stem. Replace dial insert.
7. Set dial at 450 mark. Check oven temperature again, as instructed in (3) and (4). If the oven temperature is not within 20 degrees of the dial setting (450 degrees), it means that the sensing element is inoperative and the control should be replaced.

### Oven Thermostat Control Adjustment

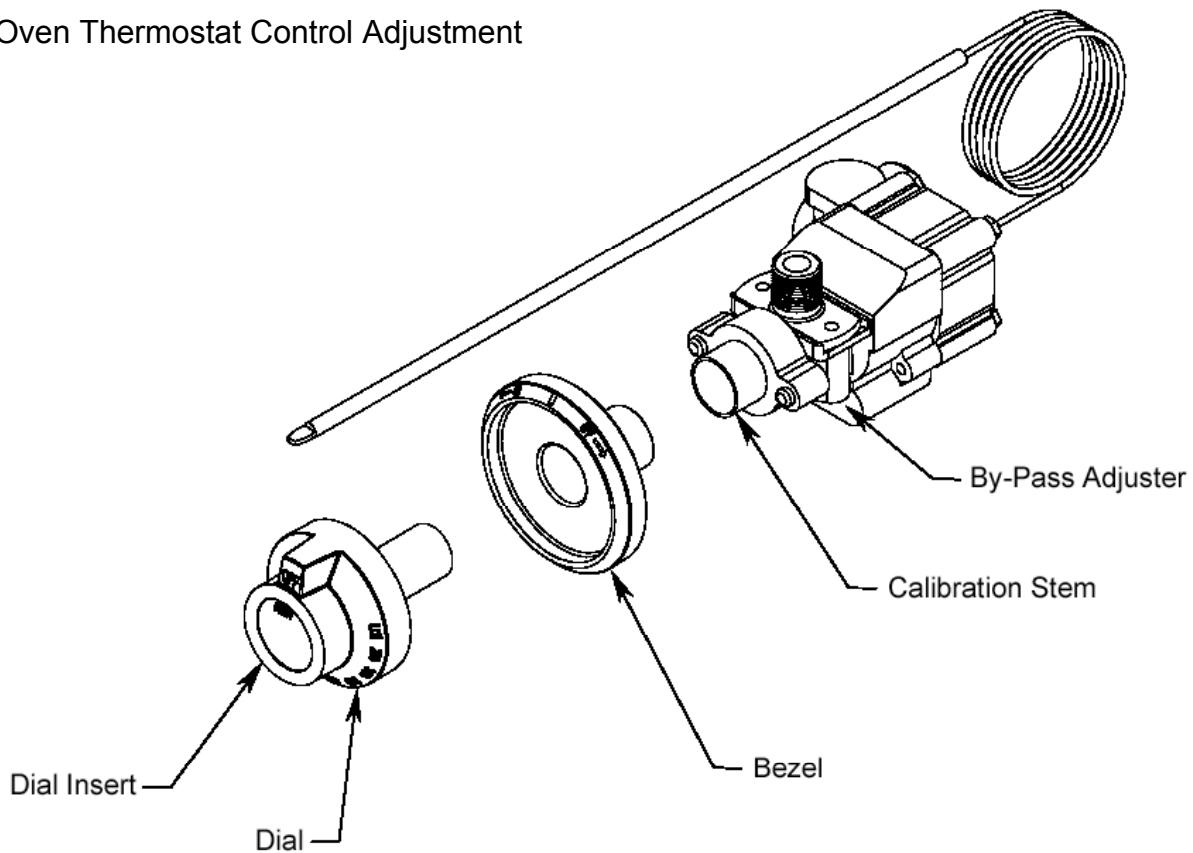

ADJUSTMENTS

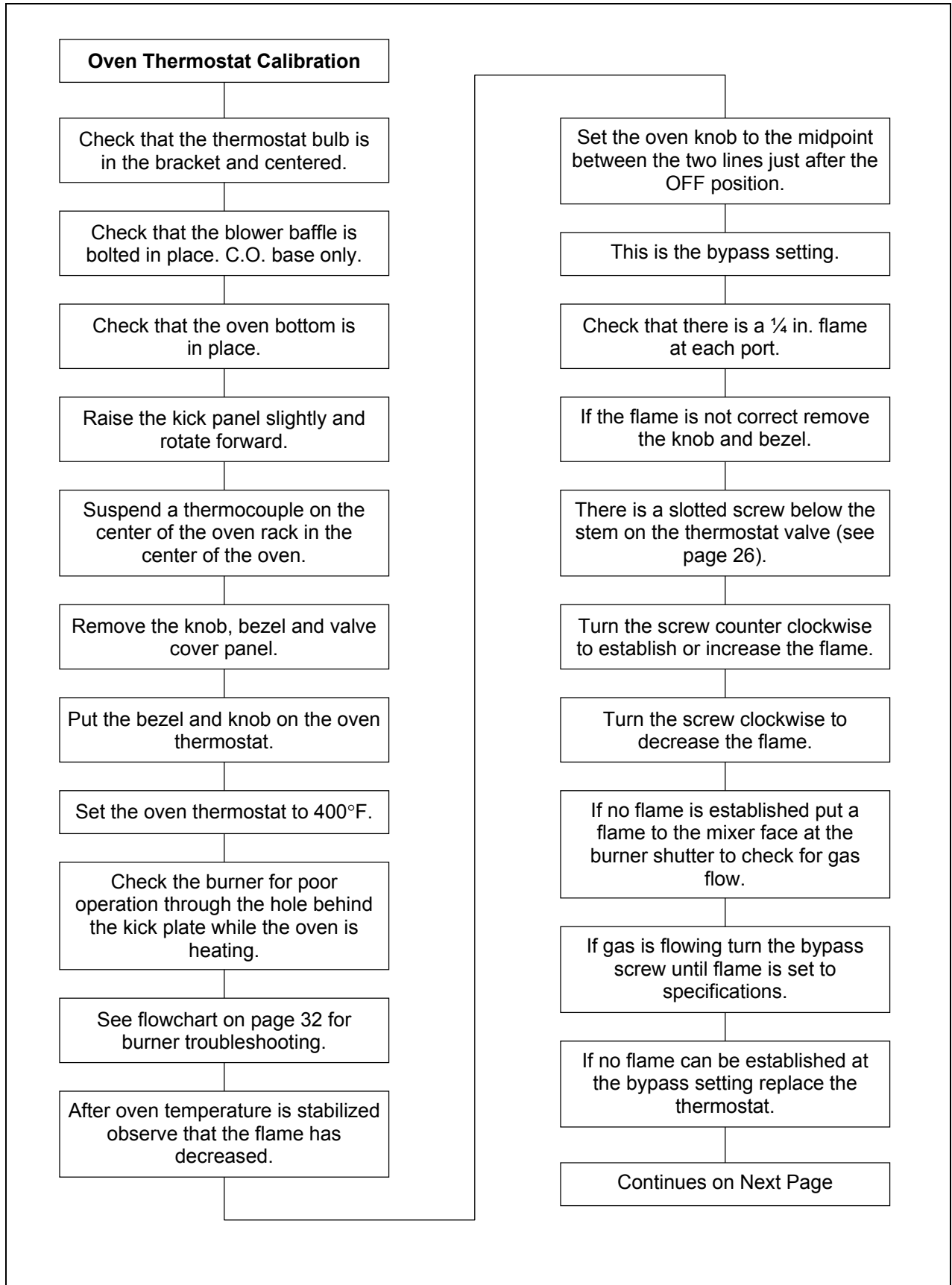

ADJUSTMENTS



ADJUSTMENTS

**Continued from Previous Page**

The bypass setting must be calibrated before calibrating the oven thermostat.

Remove the oven knob and push out the silver center from the rear of the knob and reinstall the knob on the thermostat.

Set the knob indicator to 400°F and allow the oven to reheat.

Allow the temperature to stabilize.

The temperature is stable when the change is no more than 5°F.

If the change is greater than 5°F return to the bypass calibration.

The temperature should be within +/- 10°F of the setting.

To calibrate the temperature go to the center of the thermostat.

Scrape the paint seal off of the screw.

**NOTE!** There are arrows around the screw indicating (H) to increase and (L) to decrease the temperature.

**NOTE!** Only turn this screw by small increments.

While holding the knob at the 400°F setting, push the screw in, and turn it in the direction indicated to calibrate the temperature.

Allow the temperature to stabilize.

Repeat this procedure until the temperature stabilizes to +/-10°F of the setting.

If the temperature cannot be set to within +/-10°F replace the thermostat and retest.

Reinstall the silver cover in the knob center.



## THERMOSTATIC GRIDDLE BY-PASS FLAME LEVEL

When the griddle reaches the temperature at which the dial is set, the control cuts down the flow of gas to the amount required to keep the griddle at that temperature. Always, however, the control must by-pass enough gas to keep the entire burner lighted. To maintain this minimum flame, *the by-pass must be set carefully and accurately*, as follows (see illustration on page 30):

1. Light the burner, then turn dial “FULL ON.”
2. After 5 minutes, turn dial clockwise to point slightly beyond first mark on dial.
3. Remove dial and bezel.
4. With a screwdriver, turn by-pass Adjustor (counterclockwise to increase the flame, clockwise to decrease it) until there is a minimum flame over the entire burner.
5. Replace bezel and dial, turning the dial clockwise until it locks in the “Off” position.

## THERMOSTATIC GRIDDLE THERMOSTAT CALIBRATION

The griddle temperature control is carefully calibrated at the factory—that is, it is so adjusted that dial settings match actual temperatures. Field recalibration is seldom necessary, and should not be resorted to unless considerable experience with cooking results definitely proves that the control is not maintaining the temperatures to which the dial is set.

Recalibration should not be undertaken, however, until the griddle by-pass flame has been adjusted (see previous subsection).

To check temperatures when recalibrating, use a test instrument with a **DISC** type thermocouple for surface temperature checking. Drop a couple of drops of oil on griddle surface plate and place thermocouple disc flat into the oil.

Proceed as follows (see illustration on page 30):

1. Remove dial and push out metal insert.
2. Replace dial, turn to 350 mark, and light burner.
3. After burner has been on about 15 minutes check temperature.
4. Continue to check temperature, at 5-minute intervals, until two successive readings are within 5 degrees of each other.

The control should be recalibrated if your reading is not within 20 degrees of the dial setting (350 degrees). If calibration is required, the additional steps to be taken are these:

5. Hold dial firmly, insert screwdriver through center of dial, and push calibration stem inward. **DO NOT TURN THIS STEM.**
6. While holding calibration stem in firmly with screwdriver, turn dial until it is set at the actual oven temperature as shown by your test instrument. Release pressure on calibration stem. Replace dial insert.
7. Set dial at 400 mark. Check temperature again, as instructed in (3) and (4). If the temperature is not within 20 degrees of the dial setting (400 degrees), it means that the sensing element is inoperative and the control should be replaced.

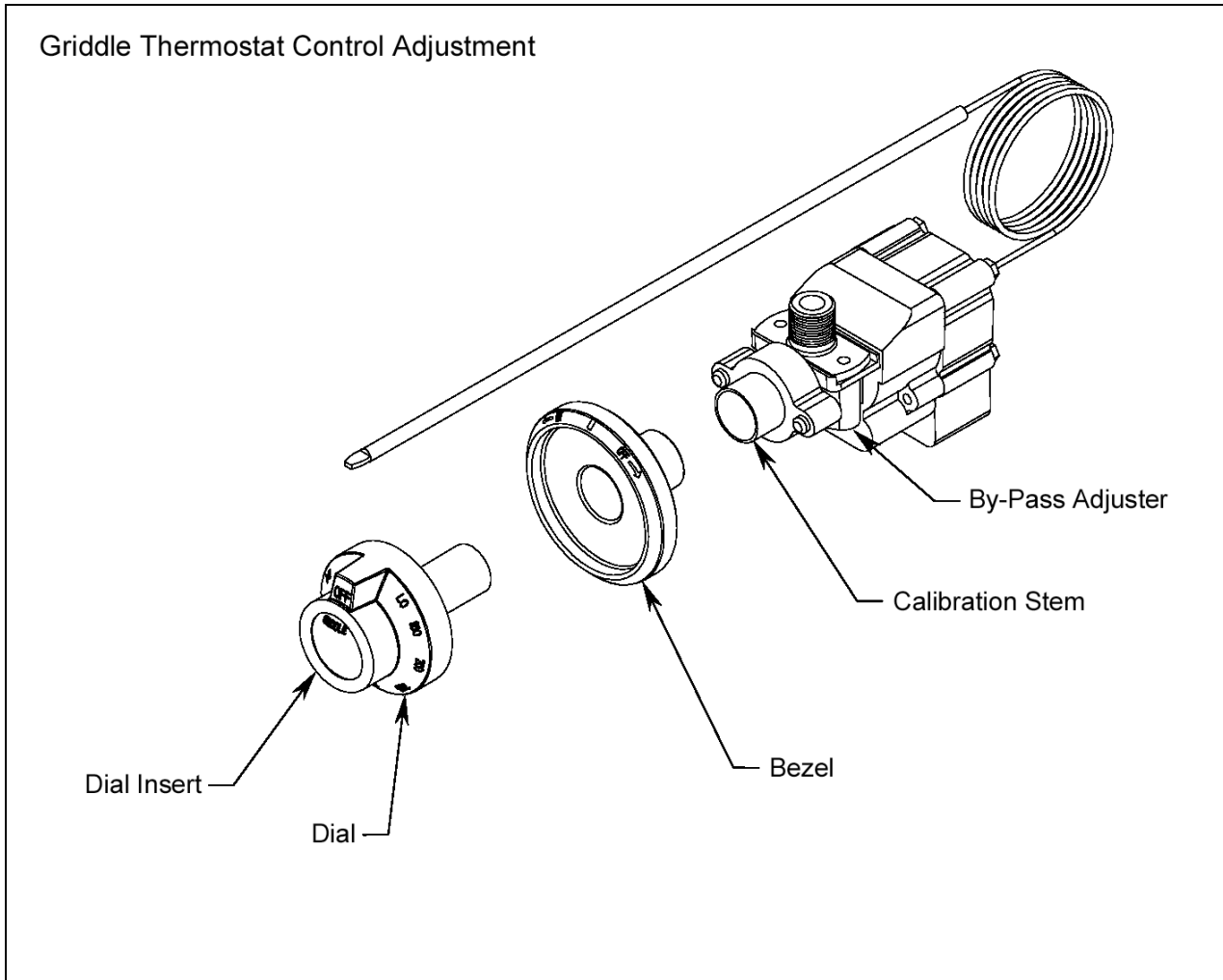

## CONVERSION FROM ONE TYPE OF GAS TO ANOTHER

Each appliance is shipped gas-specific either for use with natural gas or for use with LP gas (propane). To convert an appliance from one type of gas to another, do the following:

1. Refer to service procedures to access all burner orifices.
2. Refer to instructions included with conversion kit.
3. Follow all steps as indicated in the conversion kit.
4. Check for leaks and proper manifold pressure (the procedure is on page 24).
5. Re-light all pilots and check for proper operation.

Note: A kit for conversion to a different type of gas may be purchased from Southbend.

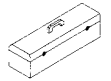

# TROUBLESHOOTING

## TROUBLESHOOTING RANGE TOP BURNERS

Consult the following table and the flowchart that begins on the following page.

<b>Problem</b>	<b>Look for -</b>
All burners and pilots in unit will not turn on	– Main gas supply to unit is “OFF.”
All burners produce excessive carbon deposits	– Incorrect gas type supplied to unit. – Incorrect supply pressure.
Only some burners in a unit produce excessive carbon deposits	– Incorrect orifices. – Primary air not adjusted properly.
Only some pilots produce excessive carbon deposits	– Pilot gas not adjusted properly. – Incorrect pilot orifice.
Top burner (not oven) will not come on	– Manual valve for top burner in “OFF” position. – Pilot out.
Top section pilot will not stay ignited	– Pilot gas not adjusted properly. – Clogged orifice. – Draft condition. – Improper ventilation system. – Air in gas line.

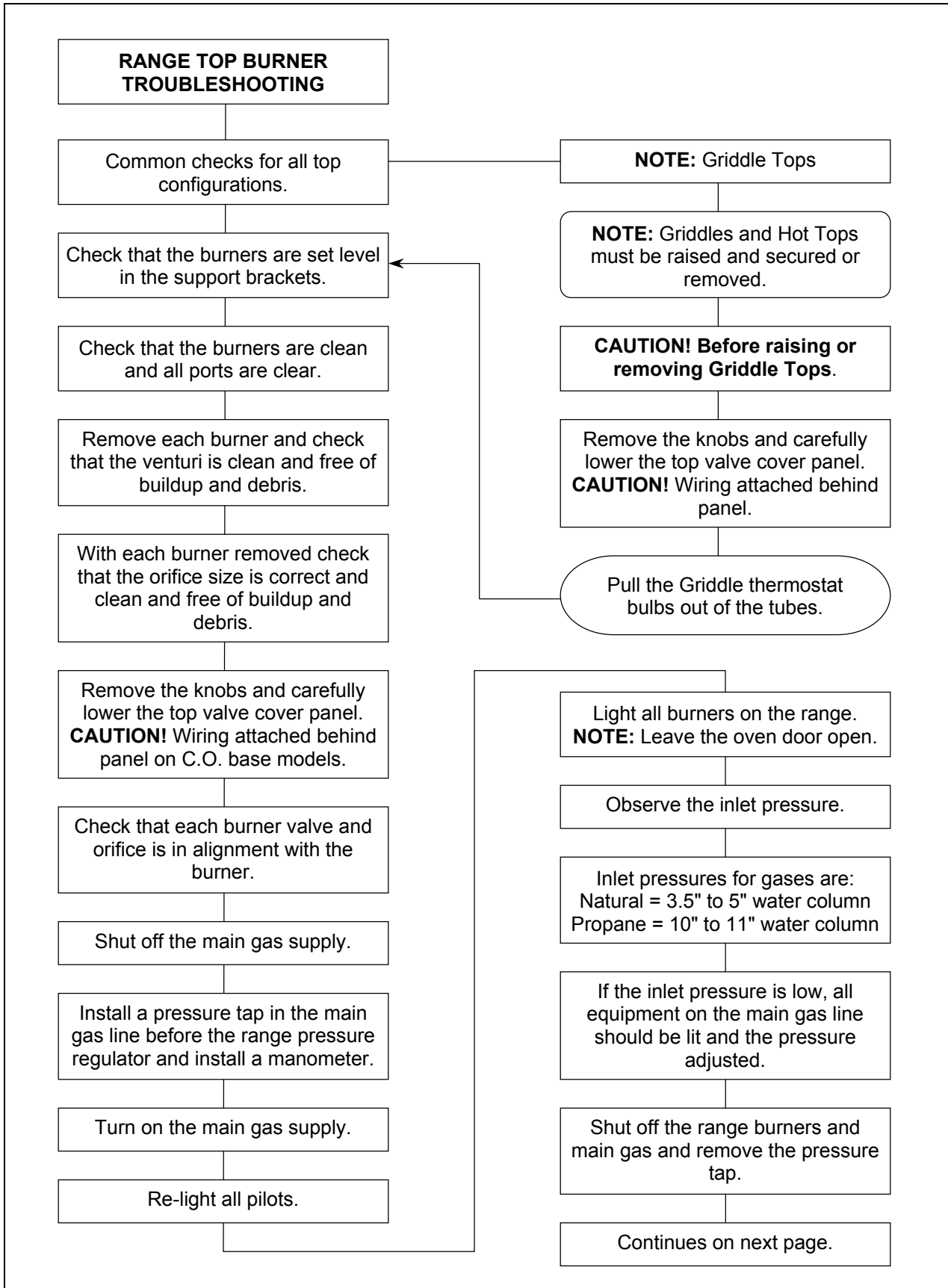



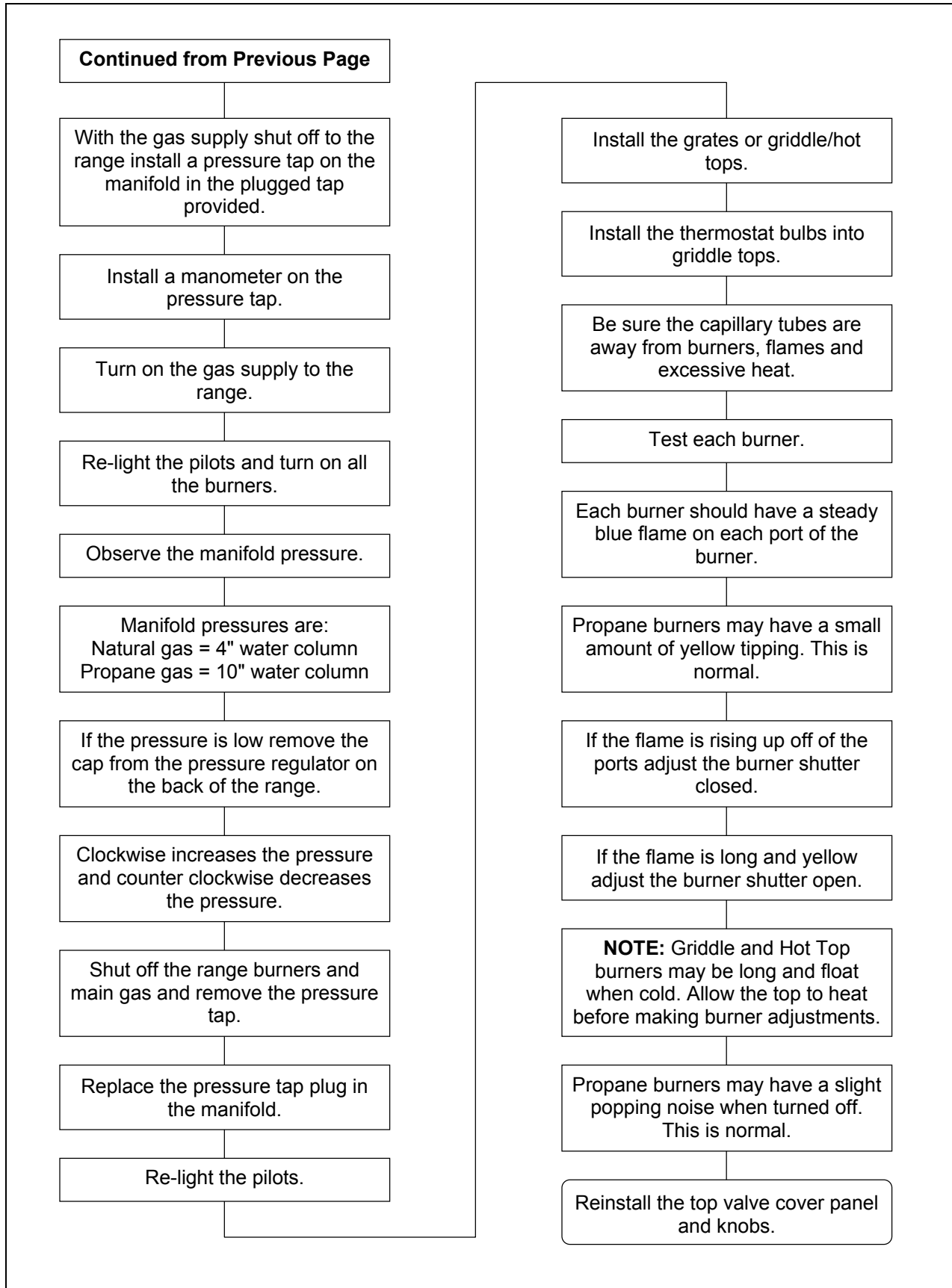
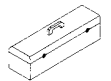

TROUBLESHOOTING



## TROUBLESHOOTING BASE OVEN

### CAUTION

Proper and efficient operation of oven is dependent on correct installation and function of components. Always verify that components are in place and functioning as intended.

Consult the following table and the flowchart that begins on the following page.

Problem	Look for -
Oven will not come on.	– Oven pilot is out.
Oven pilot will not stay ignited	<ul style="list-style-type: none"> <li>– Pilot gas not adjusted properly.</li> <li>– Bad thermocouple. (Applies to units with D suffix only)</li> <li>– Bad thermocouple connections at safety valve. (Applies to units with D suffix only)</li> <li>– Bad safety.</li> <li>– Clogged orifice.</li> <li>– Draft condition.</li> <li>– Improper ventilation system.</li> <li>– Air in gas line.</li> </ul>

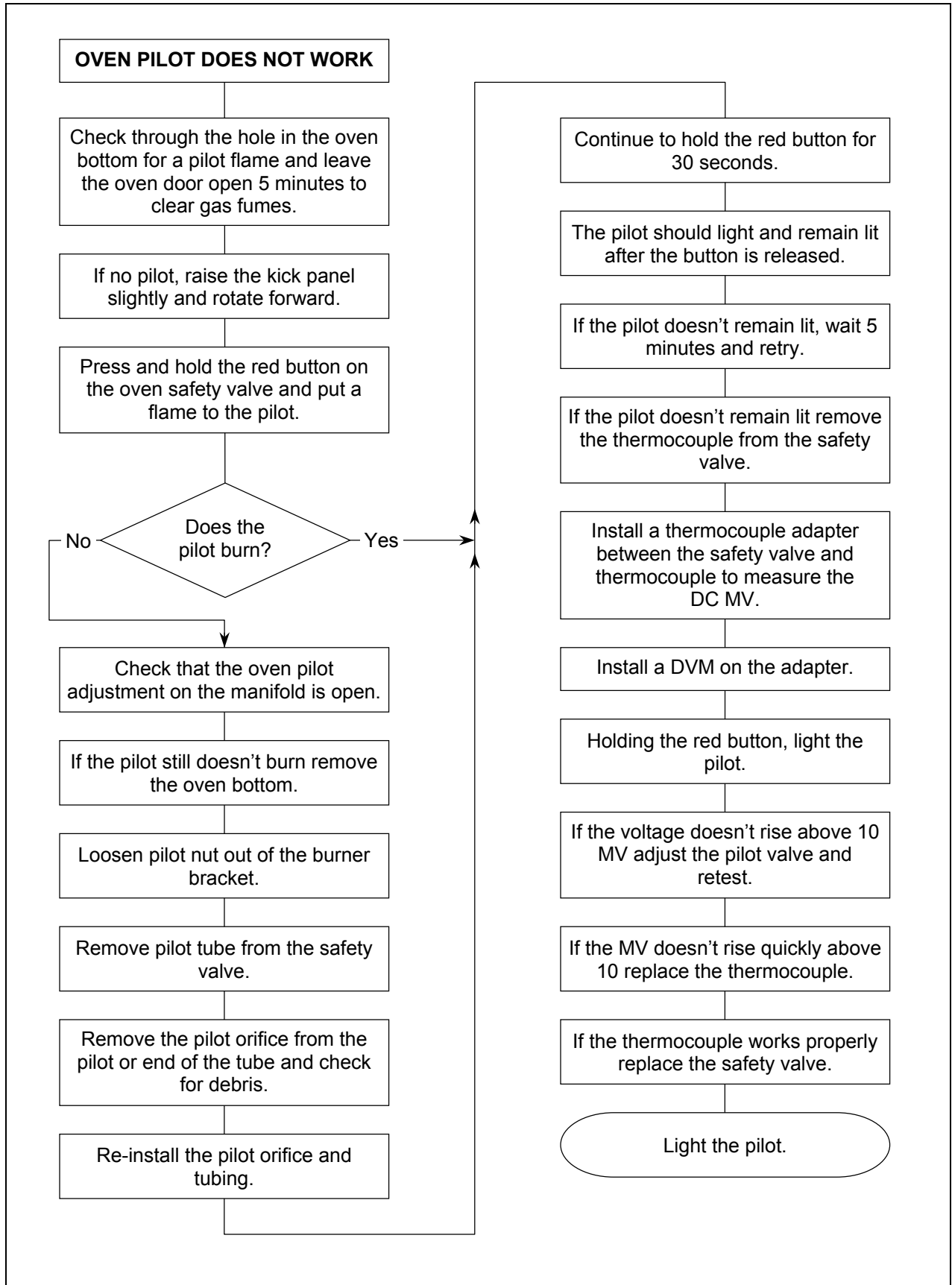
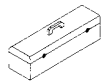

TROUBLESHOOTING



## TROUBLESHOOTING THERMOSTATIC GRIDDLE

TROUBLESHOOTING

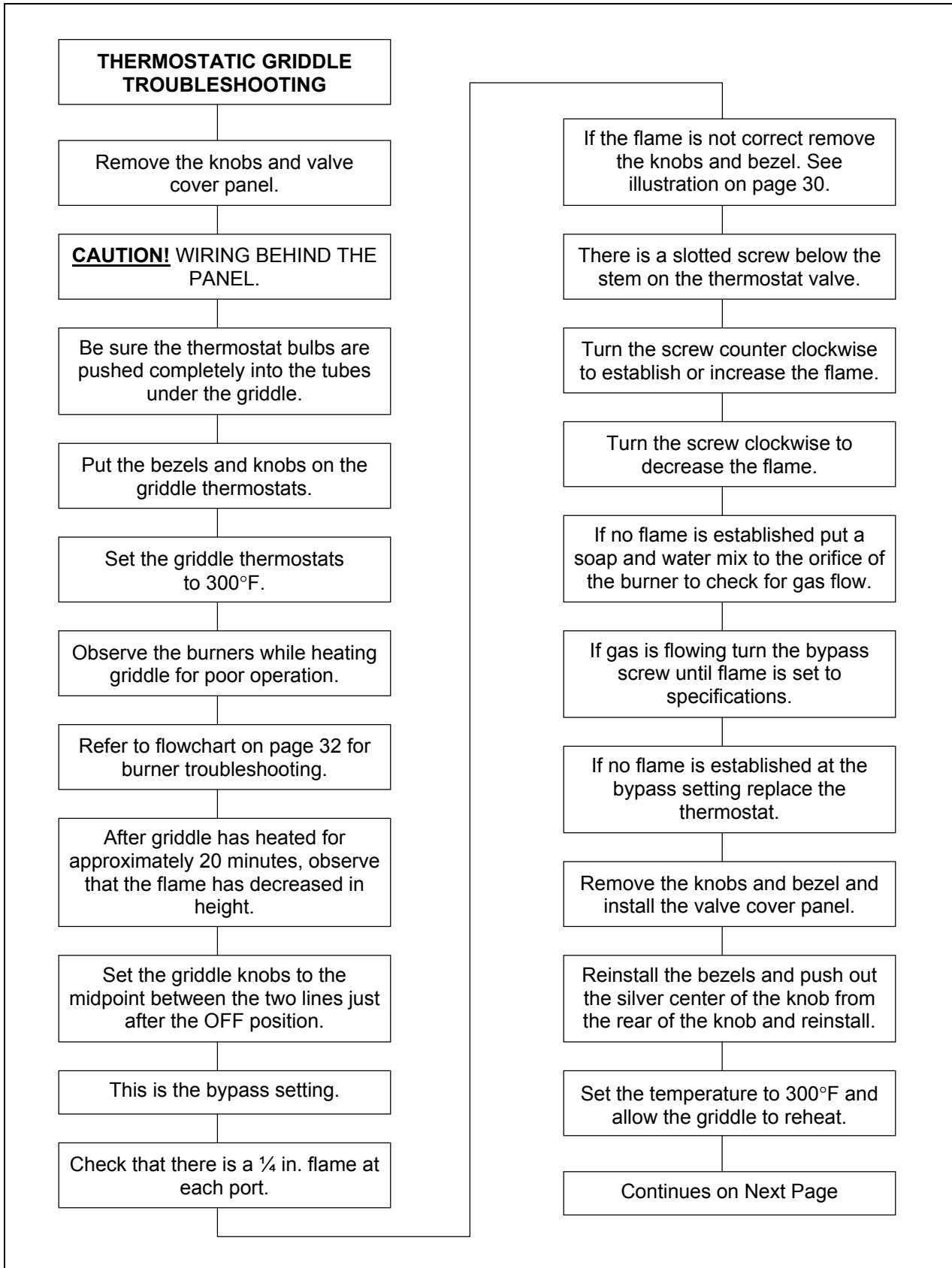

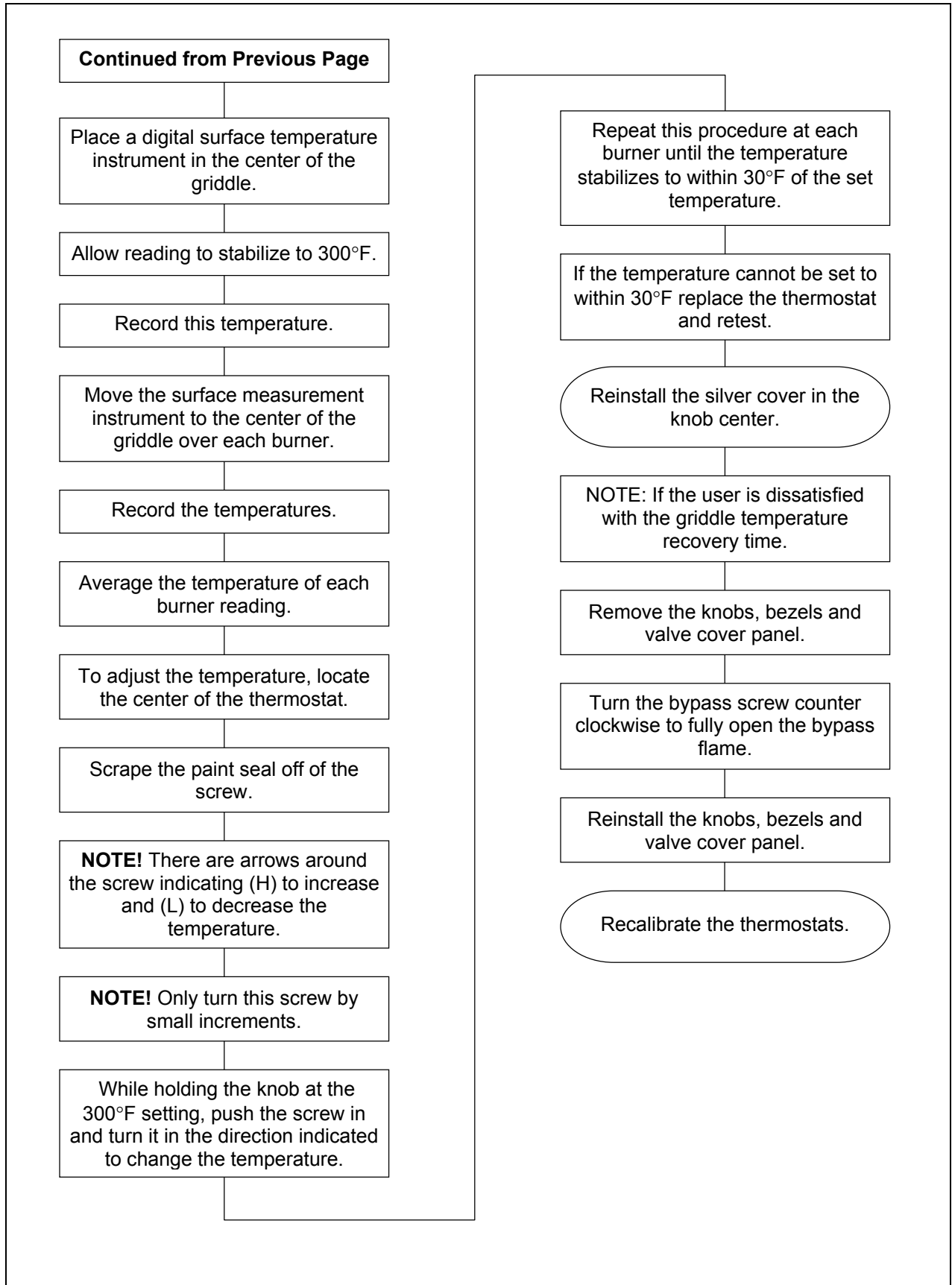
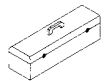

TROUBLESHOOTING



## TROUBLESHOOTING CONVECTION OVEN BLOWER MOTOR

### **WARNING**

Before attempting to service or replace any electrical component, make sure power source has been disconnected.

### **CAUTION**

When changing motor or servicing unit, always verify that blower wheel rotation is clockwise when looking into the oven cavity.

The motor is serviceable from the front of the unit through the oven cavity. Remove the back lining. Disconnect the motor mount plate by removing the eight hex nuts that secure it to the oven interior back. Pull the mount plate, with motor attached, into the oven.

Motor lubrication information can be found on permanent label located on motor.

If the blower does not run at all, consult the flowchart that begins on the next page. If the blower runs intermittently, consult the flowchart on the third page following.

The appropriate wiring diagram for the oven can be found on the rear of the oven (as well as at the end of this section of this manual).

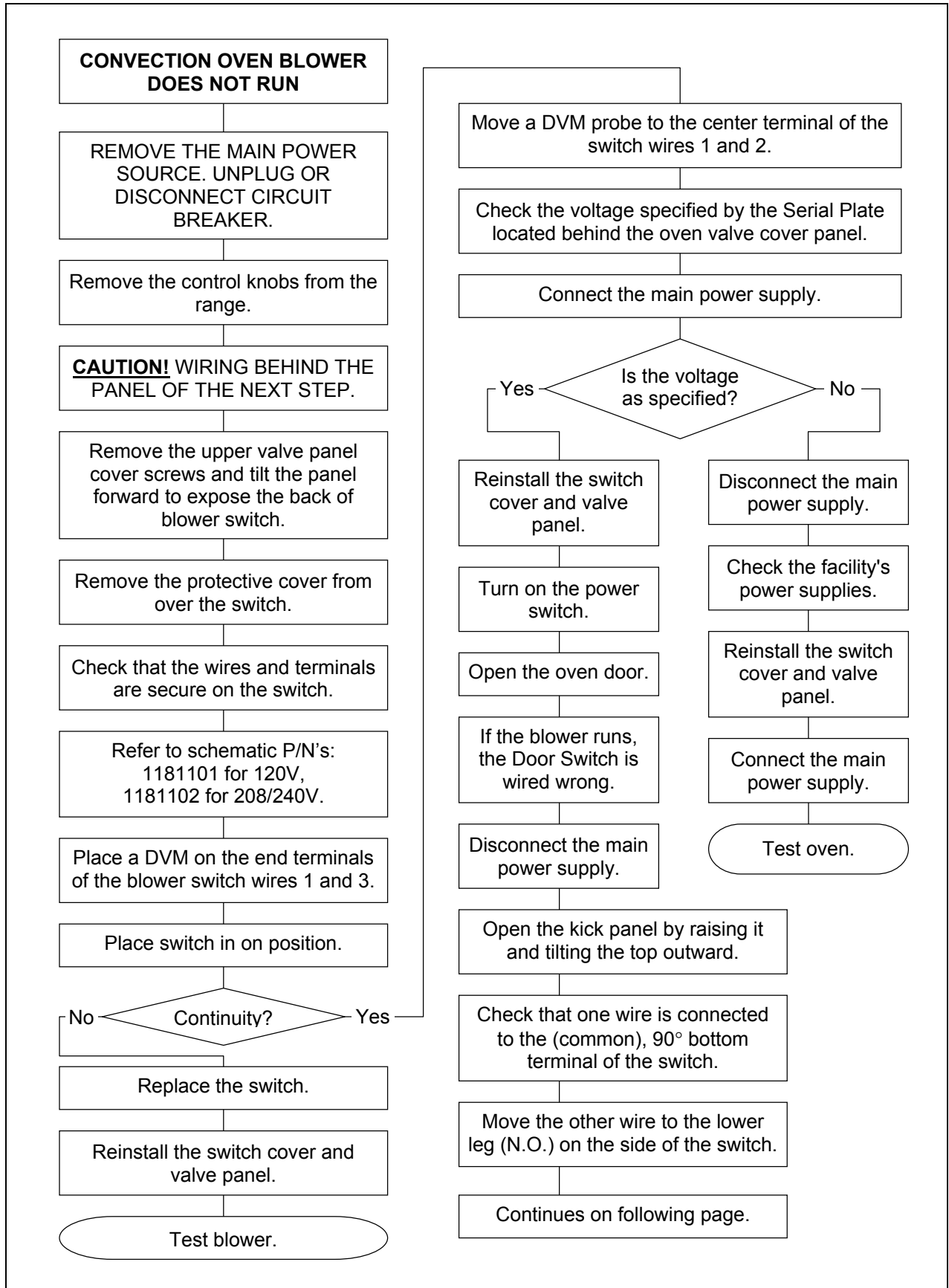
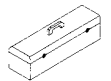

TROUBLESHOOTING

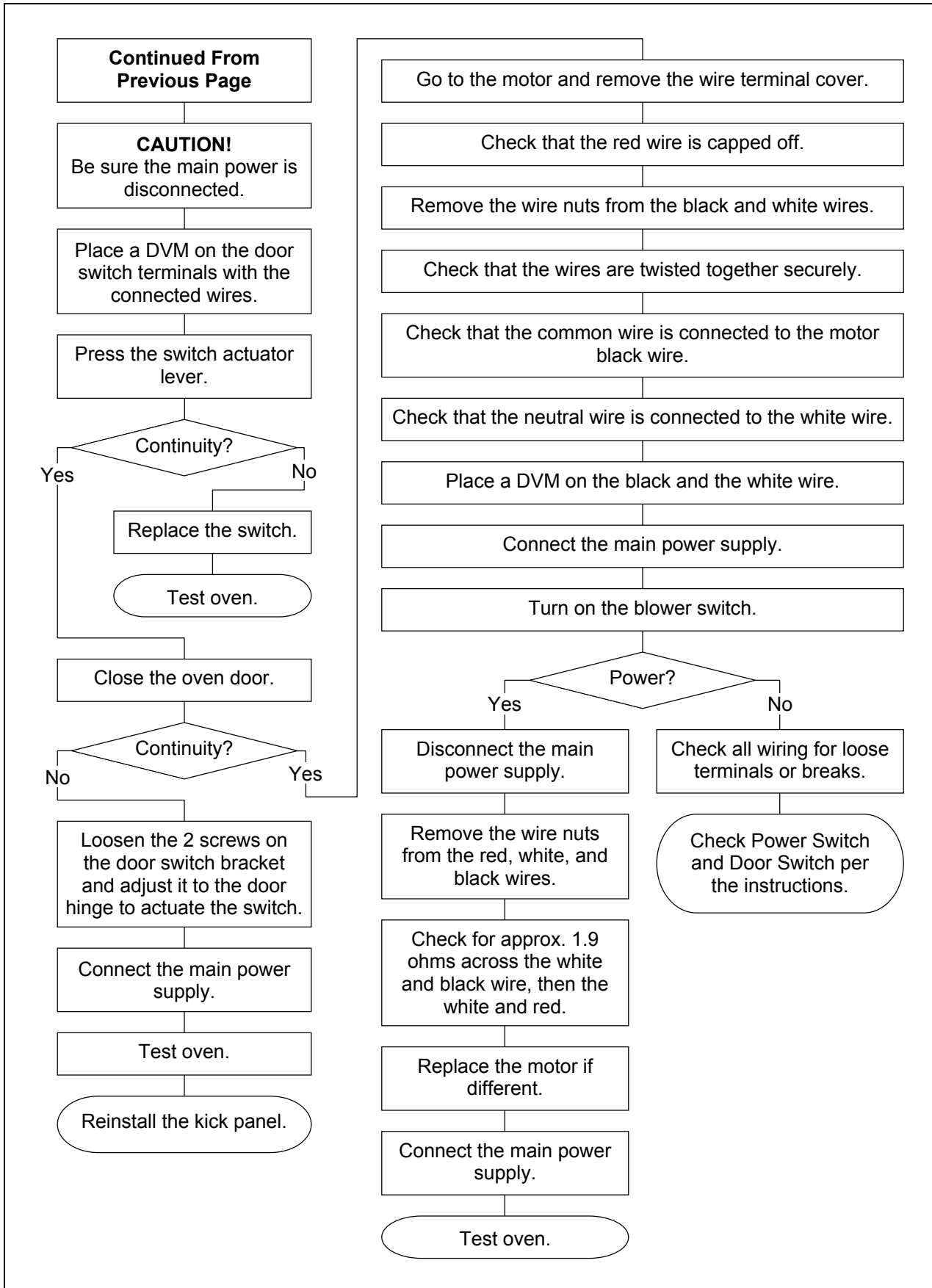



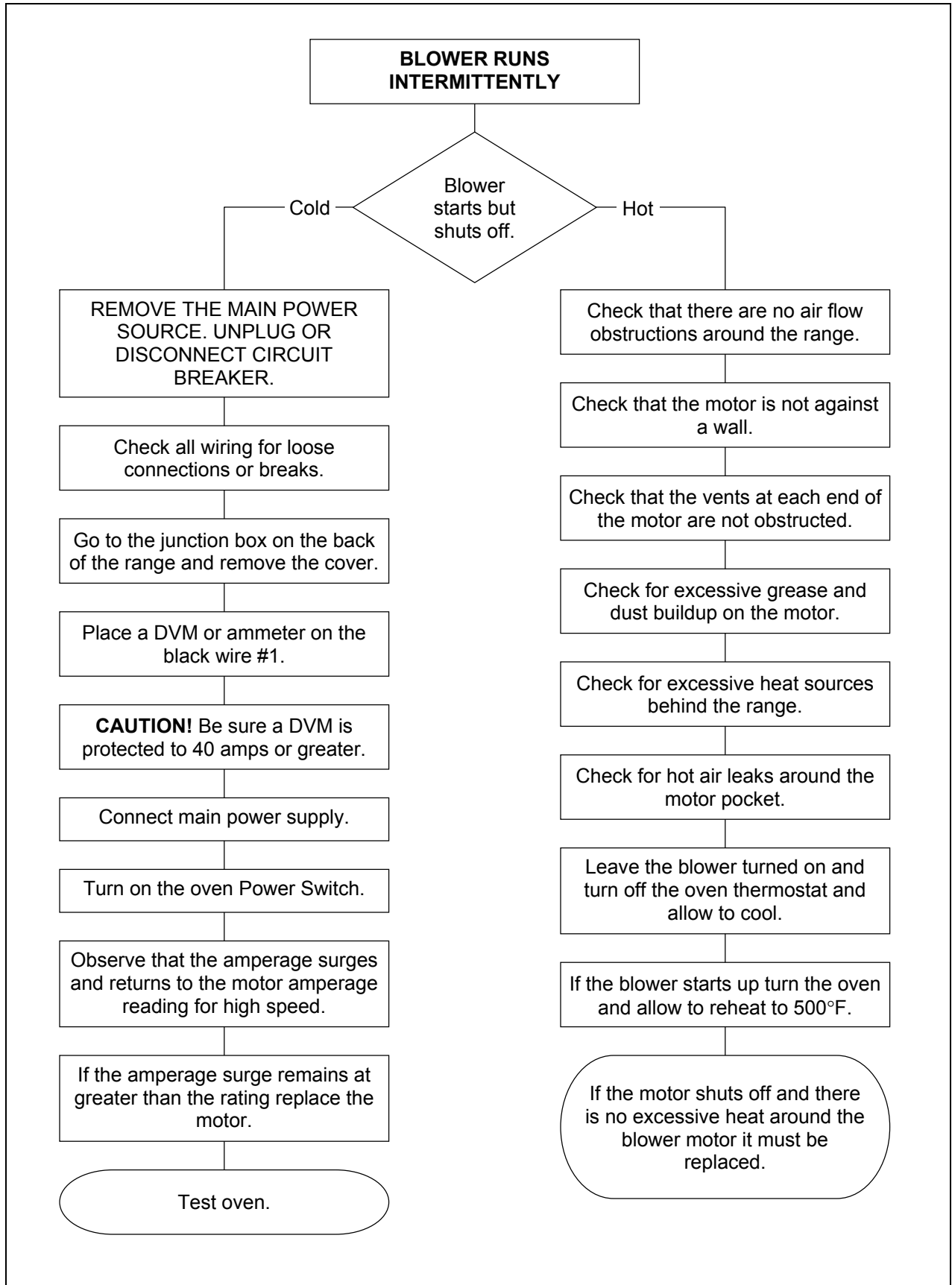
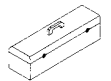

TROUBLESHOOTING



## Electrical Schematic for 120 Volt Ranges

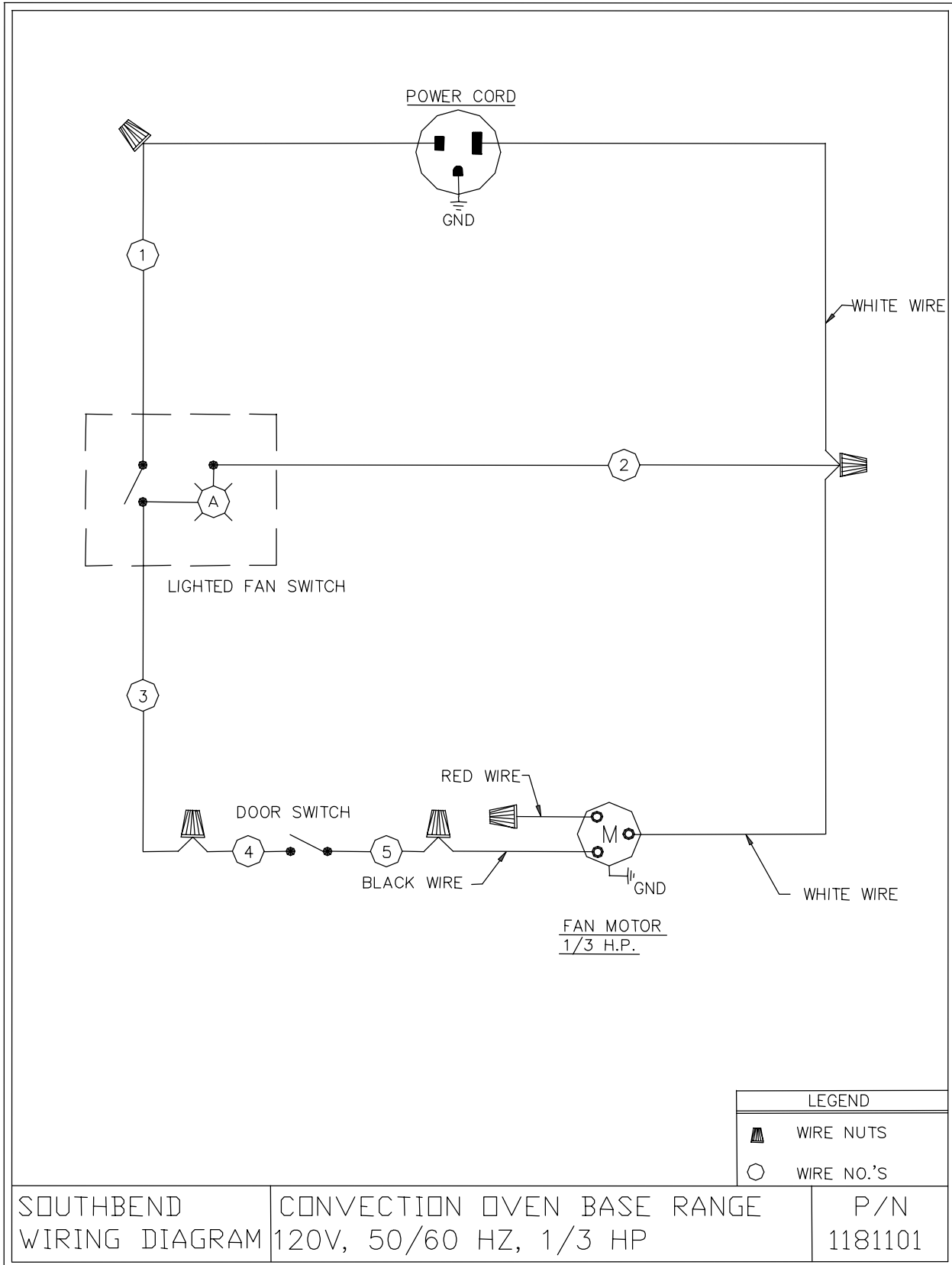

TROUBLESHOOTING

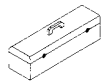

Electrical Schematic for 208-230 Volt Ranges

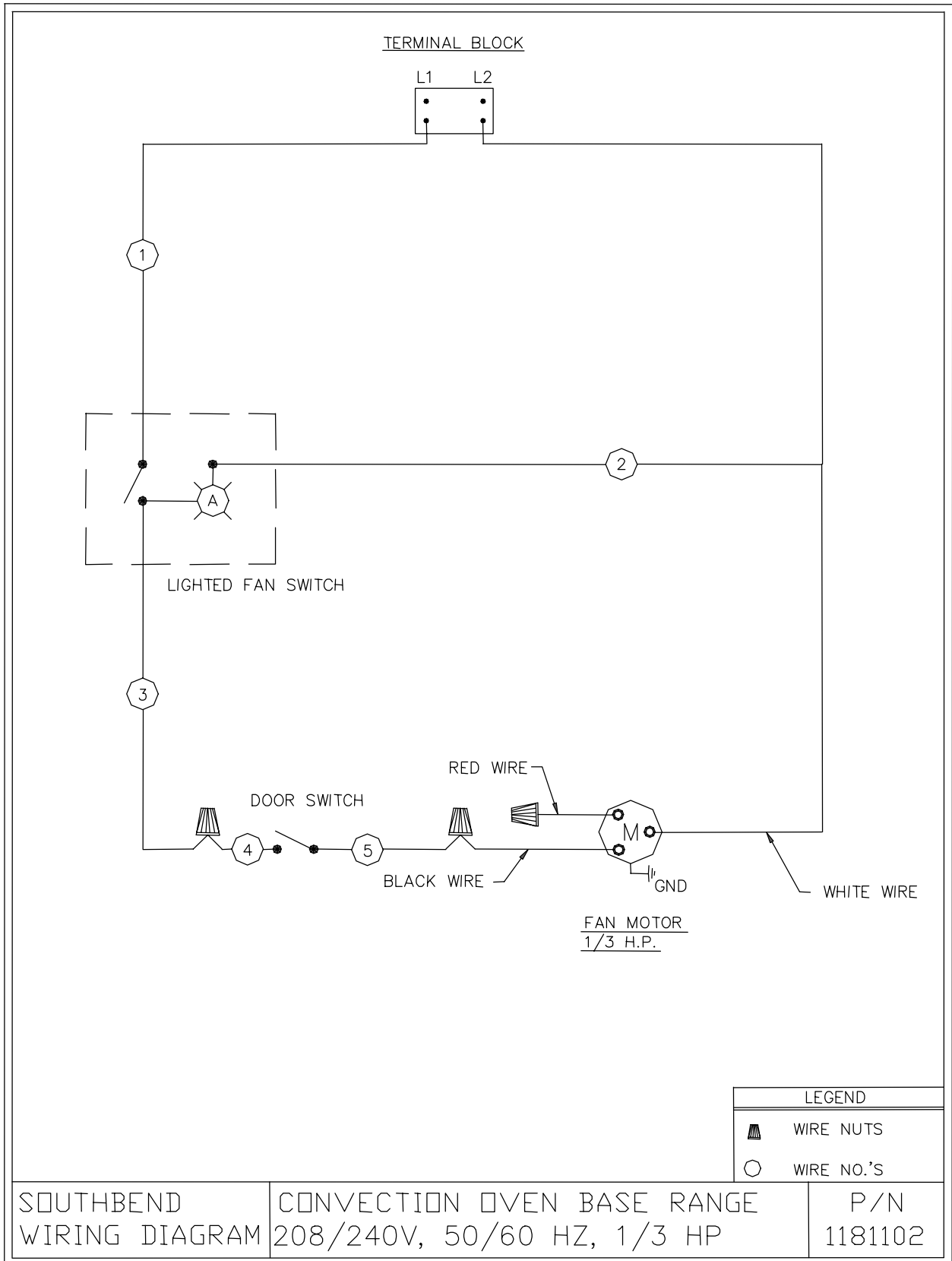

TROUBLESHOOTING

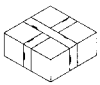

# PARTS

## ! WARNING

INSTALLATION OF OTHER THAN GENUINE SOUTHBEND PARTS WILL VOID THE WARRANTY ON THIS EQUIPMENT.

The serial plate is located in the compartment below the oven on the right side. When ordering parts, please supply the Model Number, Serial Number, Part Number, and Description; plus Finish, Type of Gas, and Electrical Characteristics, as applicable.

For parts not listed, consult a Southbend Authorized Parts Distributor or Southbend Authorized Service Agency. If necessary, please consult Southbend Parts Department for assistance.

### Index of Restaurant Range Parts Diagrams

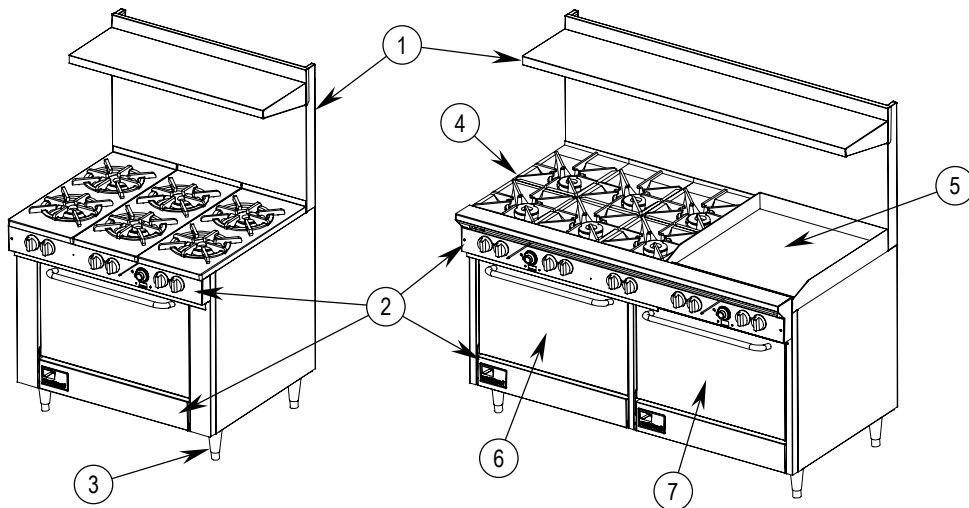

Key	Page Number	Description
1	45	Shelf and Flue Riser Parts for Models 324 and 336
	46	Shelf and Flue Riser Parts for Models 348 and 360
2	47	Valve Panel, Base Panel, and Drip Pan Parts
3	48	Leg Parts
*	48	Caster Parts
4	49	Open Top Burner Parts
5	50	24" and 36" Griddle Parts
*	52	12" Griddle Parts
*	53	Hot Top Parts
*	54	Raised-Griddle Broiler Parts
6	56	Convection Oven Parts
7	58	Standard Oven Parts
* not shown on drawing.		

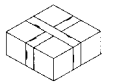

**Shelf and Flue Riser Parts for Models 324 and 336**

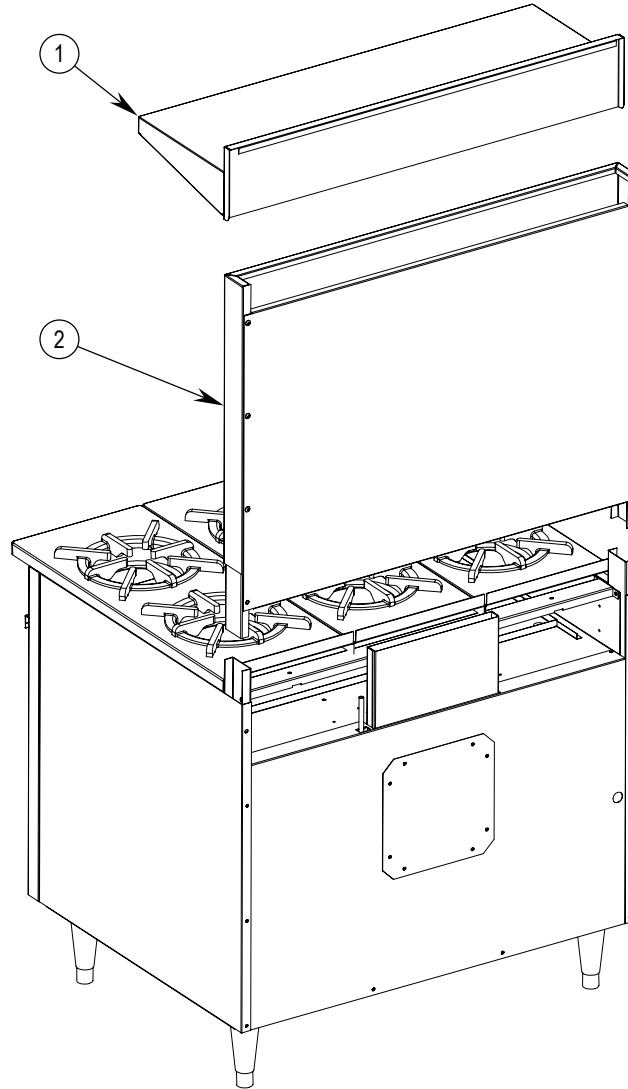

Key	Part Number	Description
1	1180842	Shelf weld assembly, 36"
*	1181141	Shelf weld assembly, 24"
2	1180766	Flue riser assembly, 22.5" x 36"
*	1181150	Flue riser assembly, 10" x 36"
*	1181151	Flue riser assembly, 22.5" x 24"
*	1181137	Flue riser assembly, 10" x 24"
* not shown on drawing.		

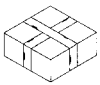

Shelf and Flue Riser Parts for Models 348 and 360

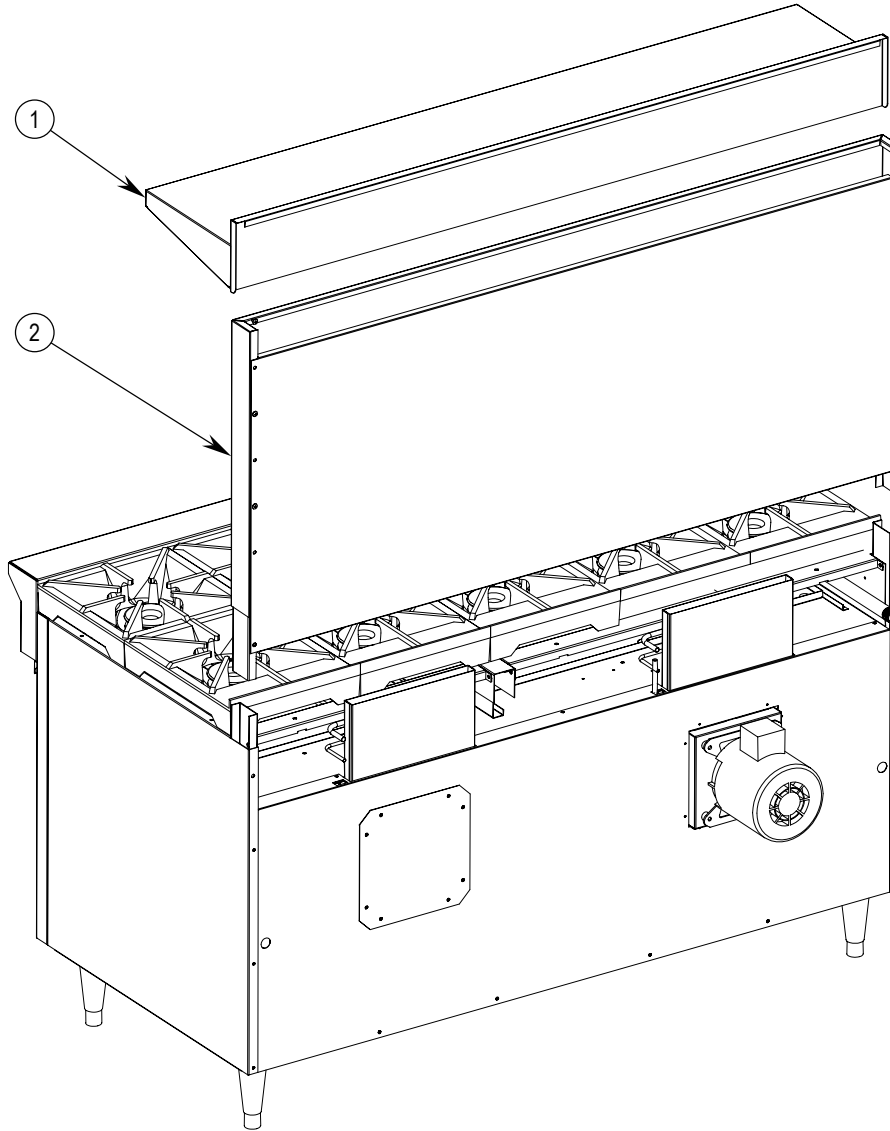

Key	Part Number	Description
1	1180845	Shelf weld assembly, 60"
*	1181140	Shelf weld assembly, 48"
2	1180768	Flue riser assembly, 22.5" x 60"
*	1181152	Flue riser assembly, 10" x 60"
*	1181136	Flue riser assembly, 22.5" x 48"
*	1181153	Flue riser assembly, 10" x 48"
* not shown on drawing.		

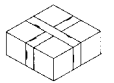

**Valve Panel, Base Panel, and Drip Pan Parts**

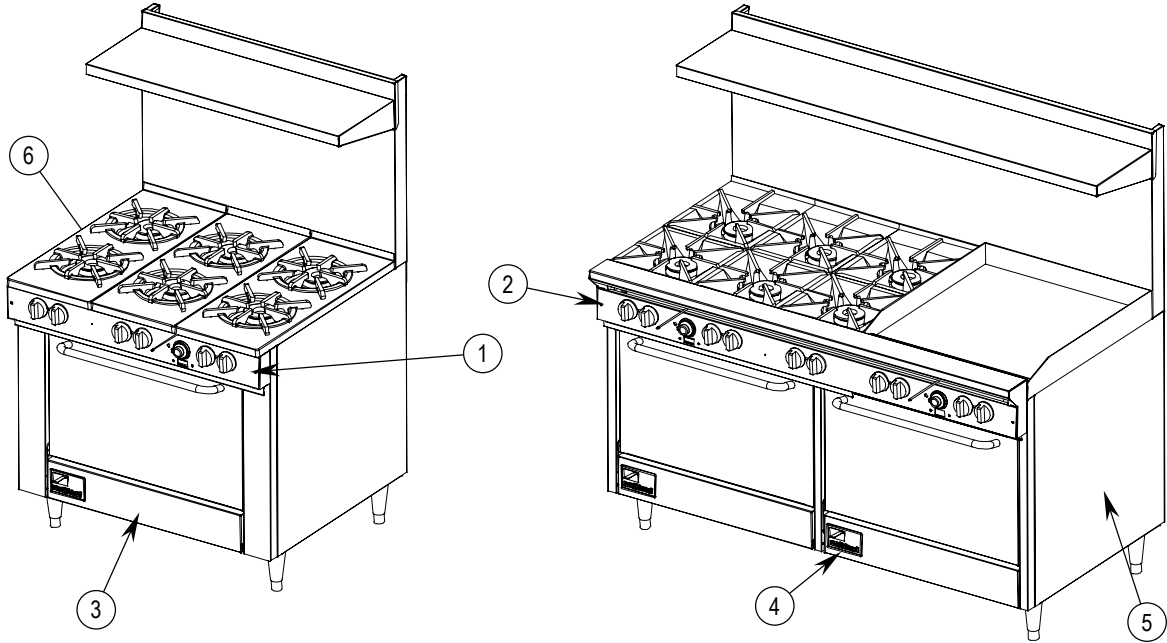

Key	Part Number	Description
1	1181187	Valve Panel for Models 324
	1180725	Valve Panel for Models 336 (shown)
	1181297	Valve Panel for Models 336-2GR/TR
	1181298	Valve Panel for Models 336-2GL/TL
	1181299	Valve Panel for Models 336-3G/T
2	1181186	Valve Panel for Models 348
	1181300	Valve Panel for Models 348-2GL/TL
	1181301	Valve Panel for Models 348-2GR/TR
	1180856	Valve Panel for Models 360 (shown)
	1181302	Valve Panel for Models 360-2GL/TL
	1181303	Valve Panel for Models 360-2GR/TR
	1181304	Valve Panel for Models 360-3GL/TL
	1181305	Valve Panel for Models 360-3GR/TR
	1181306	Bottom Valve Panel for Models 360-2RR
	1181307	Top Valve Panel for Models 360-2RR
3	1180783	Kick Panel for Full Size Ovens (A and D Series)
	1180884	Kick Panel for Space Saver Ovens (E Series)
4	1181376	Logo Plate
5	1180743	Side Panel Right
6	1180744	Side Panel Left
*	1180759	Drip Pan 36"
	1180835	Drip Pan 24"
* not shown on drawing.		

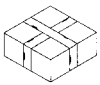

**Leg Parts**

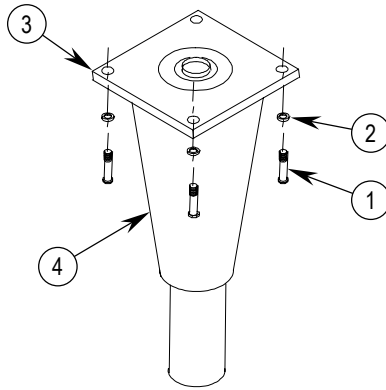

Key	Part Number	Description
1	1146201	1/4 x 20 x 3/4 Hex Head
2	1146500	1/4 Lock Washer
3	1172650	Leg Pad (3/4 x 10 hole)
4	1178205	Leg Package (set of 4 legs, not including bolts, leg pads, or lock washers)
*	1174262	Earthquake Legs SS (set of 4)

\* not shown on drawing.

**Caster Parts**

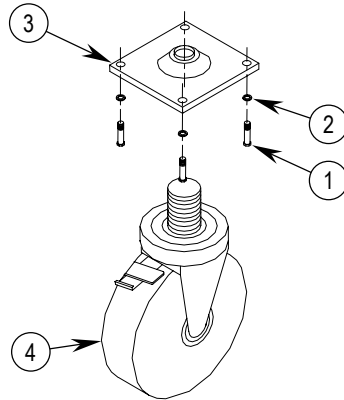

Key	Part Number	Description
1	1146201	1/4 x 20 x 3/4 Hex Head
2	1146500	1/4 Lock Washer
3	1172650	Leg Pad (3/4 x 10 hole)
4	1174265	Caster Package (two casters with brake and two without brake; does not include bolts, lock washers, or leg pads)

\* not shown on drawing.



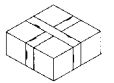

**Open Top Burner Parts**

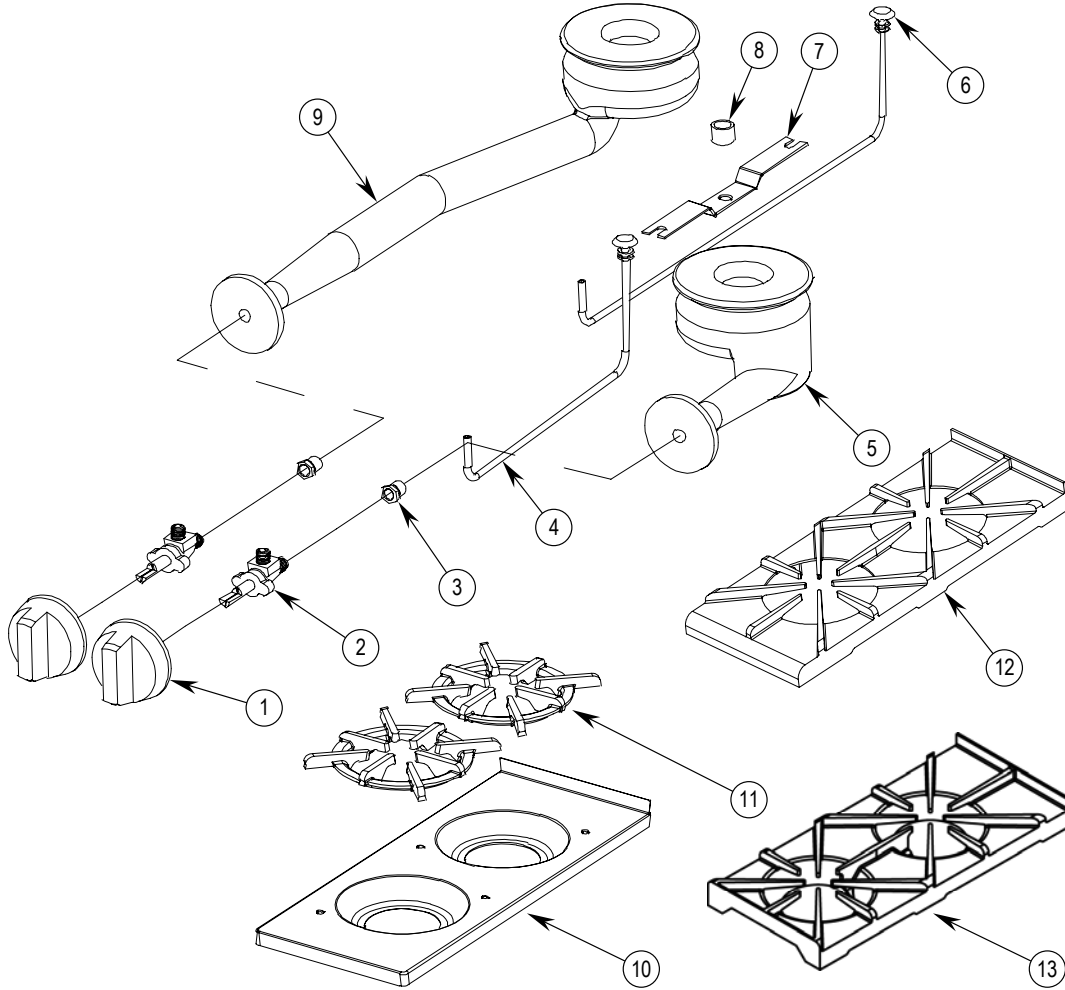

Key	Part Number	Description
1	1178204	Knob Control
2	1178202	Gas Valve
3	1008745	Hood Orifice #45 (Natural Gas)
	1008755	Hood Orifice #55 (LP Gas)
4	1177447	Pilot Assembly, Front
5	1177111	Burner Assembly, Front
6	1177448	Pilot Assembly, Rear
7	1180872	Pilot Support Bracket
8	1179710	Spacer
9	1177439	Burner Assembly, Rear
10	1107596	Enameled Top Plate (for units manufactured before January 1, 2000)
11	1160162	Spider Grate (for units manufactured before January 1, 2000)
12	1181340	Grate Top (for units manufactured after January 1, 2000 through October 13, 2003)
13	1181340	Grate Top -27" with bowl (for units manufactured after October 13, 2003)
* not shown on drawing		

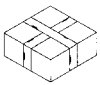
**24" and 36" Griddle Parts**

See drawing on following page.

Key	Part Number	Description	
1	1178204	Griddle Knob	
2	1178202	Valve Body Only	
3	1042980	Griddle Bar Burner	
4	1134810	Burner Support	
5	1181212	Griddle Assembly, 24", Left (for units manufactured before October 13, 2003)	
	1181213	Griddle Assembly, 24", Right (for units manufactured before October 13, 2003)	
	1181214	Griddle Assembly, 24", Left, Thermostatic (for units manufactured before October 13, 2003)	
	1181215	Griddle Assembly, 24", Right, Thermostatic (for units manufactured before October 13, 2003)	
	1181216	Griddle Assembly, 36", Left (for units manufactured before October 13, 2003)	
	1181217	Griddle Assembly, 36", Right (for units manufactured before October 13, 2003)	
	1181218	Griddle Assembly, 36", Left, Thermostatic (for units manufactured before October 13, 2003)	
	1181219	Griddle Assembly, 36", Right, Thermostatic (for units manufactured before October 13, 2003)	
	1186232	Griddle Assembly, 24", Left (for units manufactured <b>after</b> October 13, 2003)	
	1186233	Griddle Assembly, 24", Right (for units manufactured <b>after</b> October 13, 2003)	
	1186234	Griddle Assembly, 24", Left, Thermostatic (for units manufactured <b>after</b> October 13, 2003)	
	1186235	Griddle Assembly, 24", Right, Thermostatic (for units manufactured <b>after</b> October 13, 2003)	
	1186236	Griddle Assembly, 36", Left (for units manufactured <b>after</b> October 13, 2003)	
	1186237	Griddle Assembly, 36", Right (for units manufactured <b>after</b> October 13, 2003)	
	1186238	Griddle Assembly, 36", Left, Thermostatic (for units manufactured <b>after</b> October 13, 2003)	
	1186239	Griddle Assembly, 36", Right, Thermostatic (for units manufactured <b>after</b> October 13, 2003)	
	6	1162828	Griddle Pilot (for 24" griddle)
		1162980	Griddle Pilot (for 36" griddle)
7	1146906	90° Elbow	
8	P3875	1/8 x 1/4 Straight Fitting	
9	1099111	1/4 cc Nut	
10	1162236	Pilot Tube	
11	1099111	1/4 cc Nut	
12	1099112	1/4 Ferrule	
13	1163844	Pilot Adj. Valve	
14	1179997	Thermostat Knob **	
15	1174709	Thermostat Only **	
16	1147201	Brass Tee **	
17	1174713	Gas Supply Tube **	
18	1008748	Orifice NAT **	
	1008755	Orifice LP **	
19	1166150	Brass Elbow **	
20	1174714	Gas Supply Tube **	
*	1008748	Griddle Orifice NAT	
*	1008756	Griddle Orifice LP	
*	1181221	Grease Drawer	
* not shown on drawing.			
** used on thermostatically controlled griddles (indicated by a "T" prefix)			

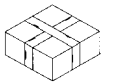

### 24" and 36" Griddle Parts

See parts list on previous page.

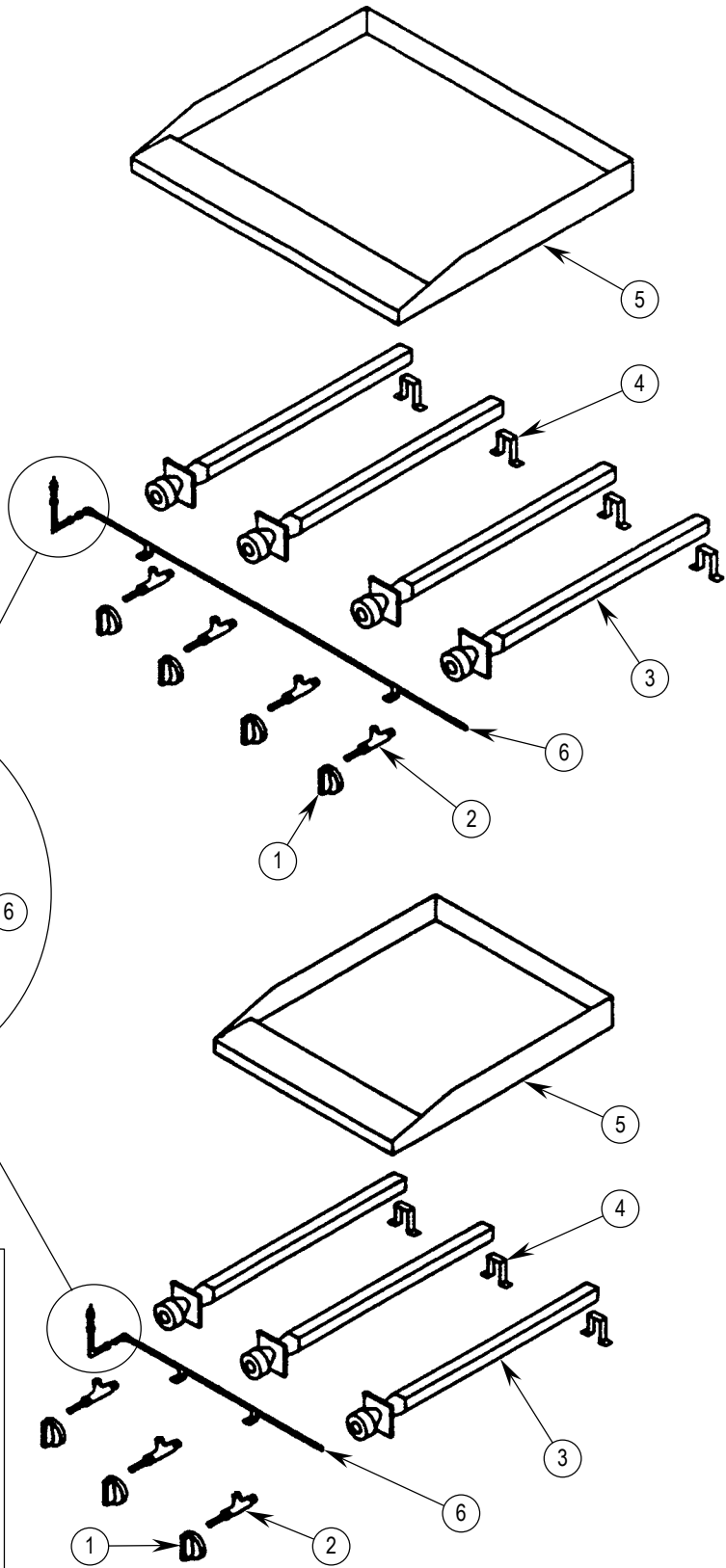
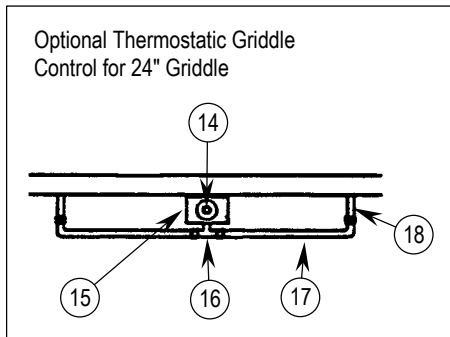
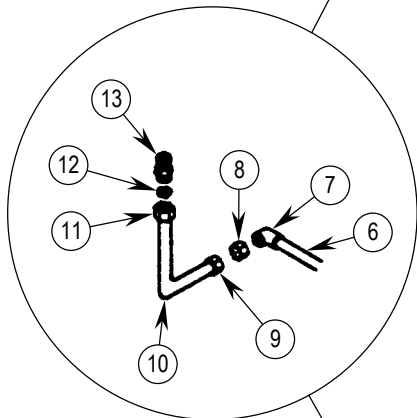
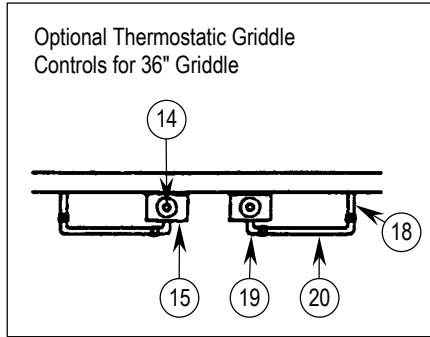

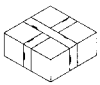

12" Griddle Parts

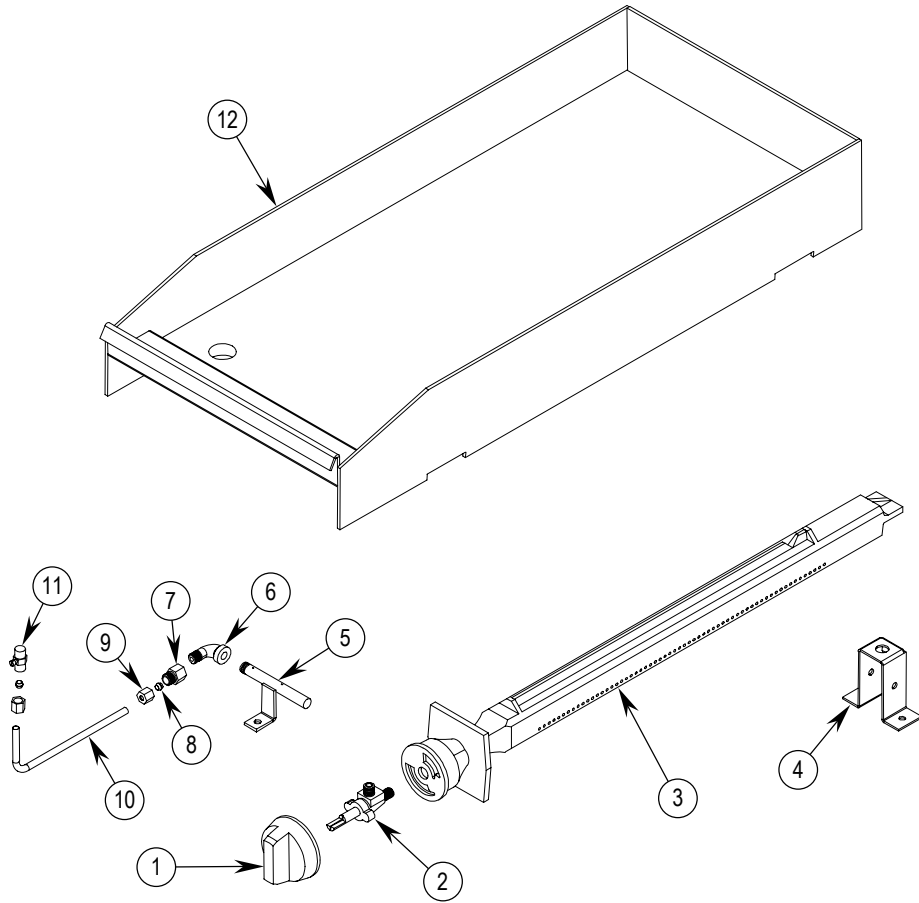

Key	Part Number	Description
1	1178204	Knob, Control
2	1178202	Valve, Hi-Off
3	1042980	Burner, Bar Assembly
4	1134810	Burner Support
5	1162807	Lighter Pipe Weld Assembly
6	1146906	Elbow 90 Deg, Street
7	P3875	Str. Fitting 1/8 THD 1/4 Less Nut/Sleeve
8	1099112	Ferrule, 1/4
9	1099111	Nut, 1/4 CC
10	1162236	Pilot Tube (7.500)
11	1099002	Pilot Adjustment Valve
12	1181723	Griddle Weld Assembly 12" Left (for units manufactured before October 13, 2003)
	1186231	Griddle Weld Assembly 12" Left (for units manufactured <b>after</b> October 13, 2003)
*	1181221	Grease Drawer Assembly
*	1008748	Orifice NAT Gas
*	1008756	Orifice LP Gas

\* not shown on drawing.

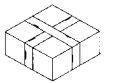

**Hot Top Parts**

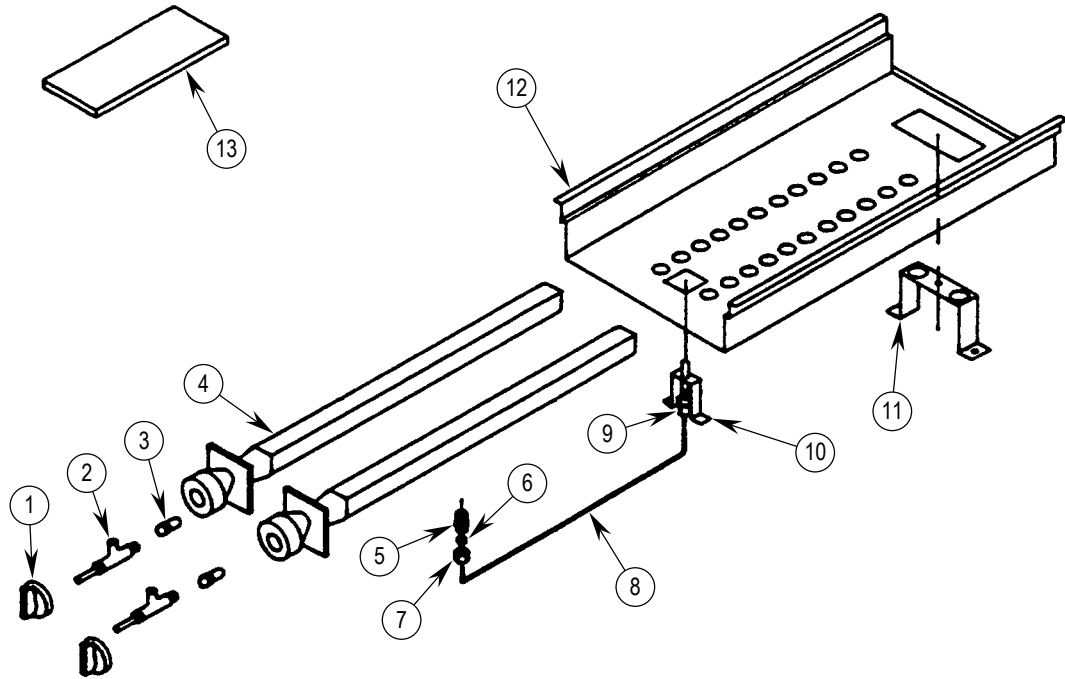

Key	Part Number	Description
1	1178204	Knob Control
2	1178202	Gas Valve
3	1008751	Hood Orifice NAT
	1008757	Hood Orifice LP
4	1022994	Hot Top Burner
5	1099002	Filter & Valve
6	1099101	1/8 Reduction Ferrule
7	1099100	1/8 cc Nut
8	3346	Pilot Tube
9	1160410	Pilot Assembly
10	3435	Pilot Bracket
11	3448	Burner Support
12	1170417	Aeration Box
13	1112299	Top Plate Assembly

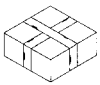

**Raised-Griddle Broiler Parts**

See drawing on following page.

Key	Part Number	Description
1	1161636	Broiler Dirt Tray
2	1173555	Broiler Rack Pan
3	1173554	Broiler Rack
4	1173556	Broiler Rack Support
5	1133999	Griddle Pilot
6	P3875	1/8 x 1/4 Straight Fitting
7	1099112	1/4 Ferrule
8	1099111	1/4 cc Nut
9	1162935	Gas Supply Tube
10	1099111	1/4 Nut
11	1099112	1/4 Ferrule
12	1163844	Pilot Adj. Valve
13	1073495	Broiler Valve Handle
14	1146304	Screw # 10 x 1/2 Phil
15	1178202	Broiler Valve
16	P3111	Ceramic (side) 3-1/2 x 7-1/2 x 1/2
17	P3112	Ceramic (center) 6-9/16 x 7-1/2 x 1/2
18	1162925	Broiler Burner (center)
19	1162924	Broiler Burner (side)
20	1030200	Burner Rest Bracket
21	3240	Rear Plate Rest Broiler
22	1009199	Griddle Plate
23	1042980	Griddle Burner
24	1162334	Griddle Pilot
*	1008749	Broiler Burner Orifice RT & LT NAT
*	1008757	Broiler Burner Orifice RT & LT LP
*	1008753	Broiler Burner Orifice Center NAT
*	1008765	Broiler Burner Orifice Center LP
* not shown on drawing		

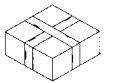

### Raised-Griddle Broiler Parts

See parts list on previous page.

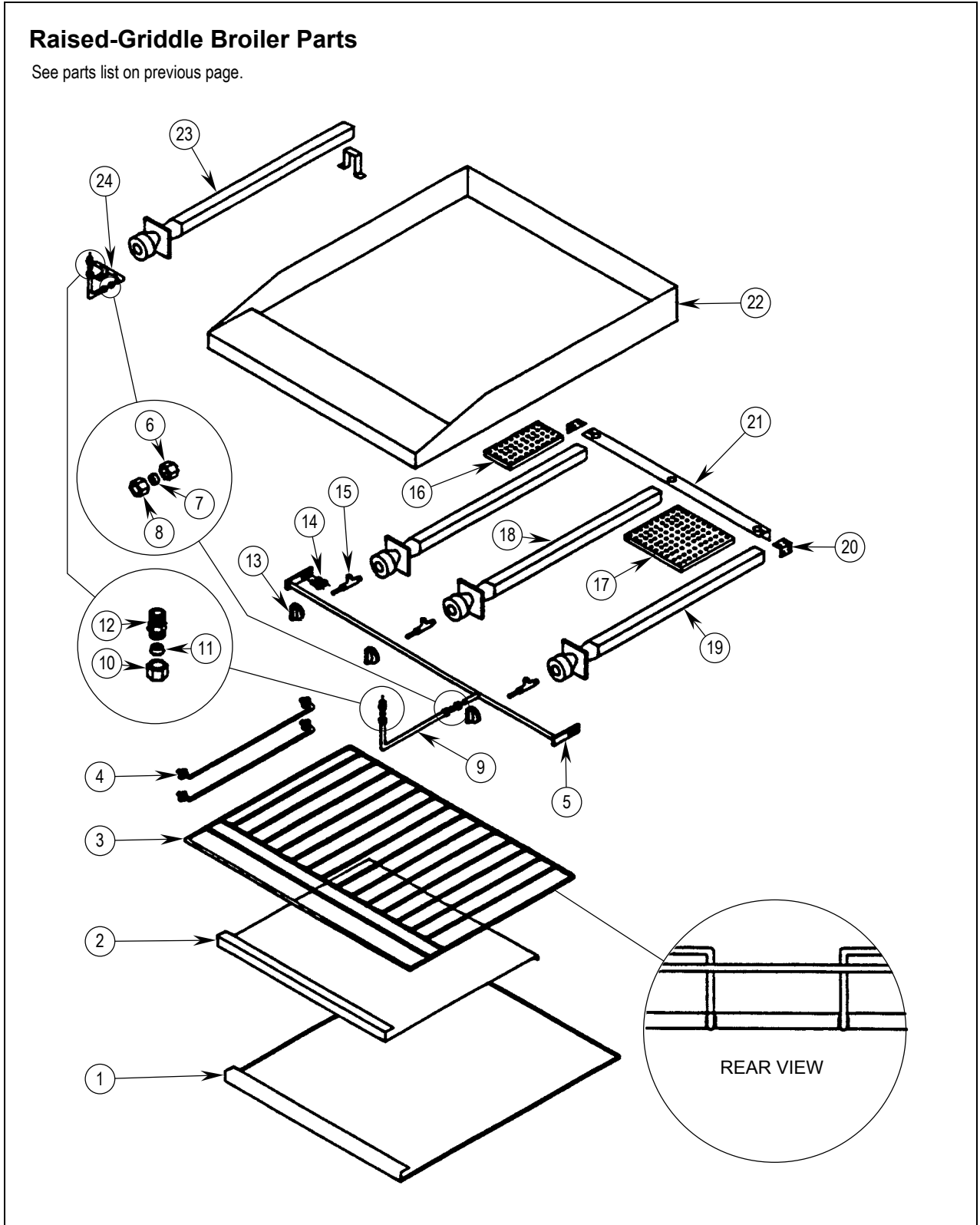

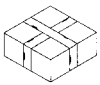

**Convection Oven Parts**

See drawing on following page.

Key	Part Number	Description
1	1180783	Panel, Kick
2	1181376	Logo Plate
3	1180861	Door Hinge
4	1024196	Door Assembly (Full Oven)
	1179072	Door Assembly (Space Saver Oven)
5	1179950	Door Handle (Full Oven)
	1179952	Door Handle (Space Saver Oven)
*	P1089	Spring, Door (Full Oven)
	1179030	Spring, Door (Space Saver Oven)
6	6660	Clip, Rack Support
7	1180528	Rack Guide
8	1177581	Blower Wheel Assembly
9	1180821	Pocket Weld Assembly
10	1179710	Spacer, Blower
11	1177452	Motor, 1/3 HP, 115 Volt
	1179688	Motor, 1/3 HP, 208/240 Volt
12	1181117	Bracket, Door Switch
13	1177567	Switch, Door
14	1180859	Quadrant Assembly
15	1180834	Oven Baffle Co.
16	1180841	Bracket, Oven Baffle
17	1180776	Oven Bottom (Full Oven)
	1180853	Oven Bottom (Space Saver Oven)
18	1164278	SA Burner (Natural Gas)
	1164279	SA Burner (LP Gas)
19	1164037	Oven Safety Valve
20	1008736	Hood Orifice #36 (Natural Gas)
	1008752	Hood Orifice #52 (LP Gas)
21	1180873	Pilot Tube
22	1163868	Thermocouple
23	1180830	Bracket, Oven Safety

\* not shown on drawing



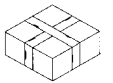

### Convection Oven Parts

See parts list on previous page.

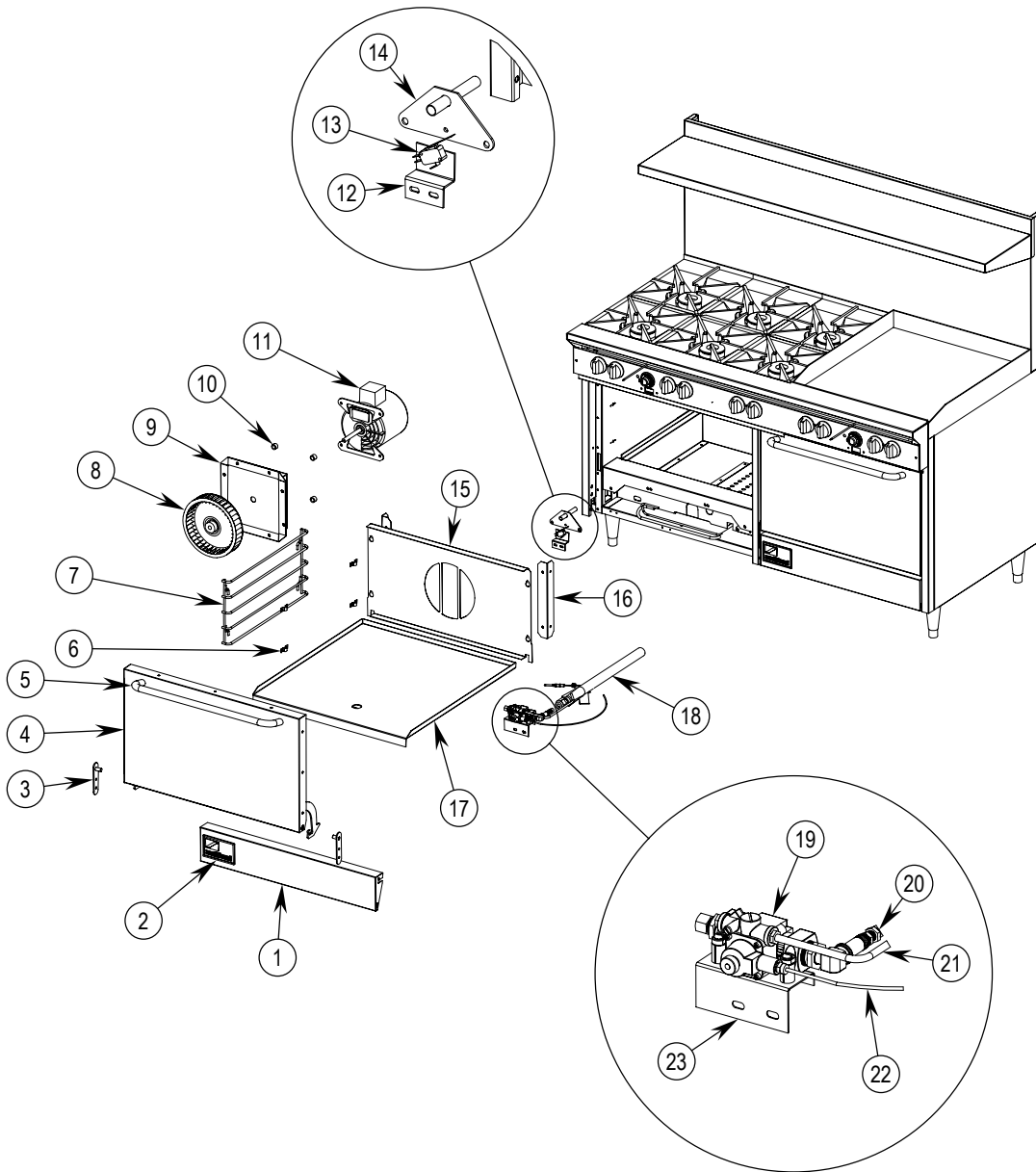

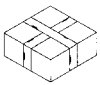

<b>Standard Oven Parts</b>		
See drawing on following page.		
Key	Part Number	Description
1	1024196	Door Assembly (Full Oven)
	1179072	Door Assembly (Space Saver Oven)
2	1180861	Door Hinge
*	P1089	Spring, Door (Full Oven)
	1179030	Spring, Door (Space Saver Oven)
3	1180776	Oven Bottom (Full Oven)
	1180853	Oven Bottom (Space Saver Oven)
4	1173547	Rod, Oven
5	1180859	Quadrant Assembly
6	1164278	SA Burner (Natural Gas)
	1164279	SA Burner (LP Gas)
7	1179998	Dial Knob, Oven
8	1179999	Bezel
9	B940000201	Thermostat
10	1164037	Oven Safety Valve
11	1008736	Hood Orifice #36 (Natural Gas)
	1008752	Hood Orifice #52 (LP Gas)
12	1180873	Pilot Tube
13	1163868	Thermocouple
14	1180830	Bracket, Oven Safety
* not shown on drawing		

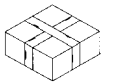

### Standard Oven Parts

See parts list on previous page.

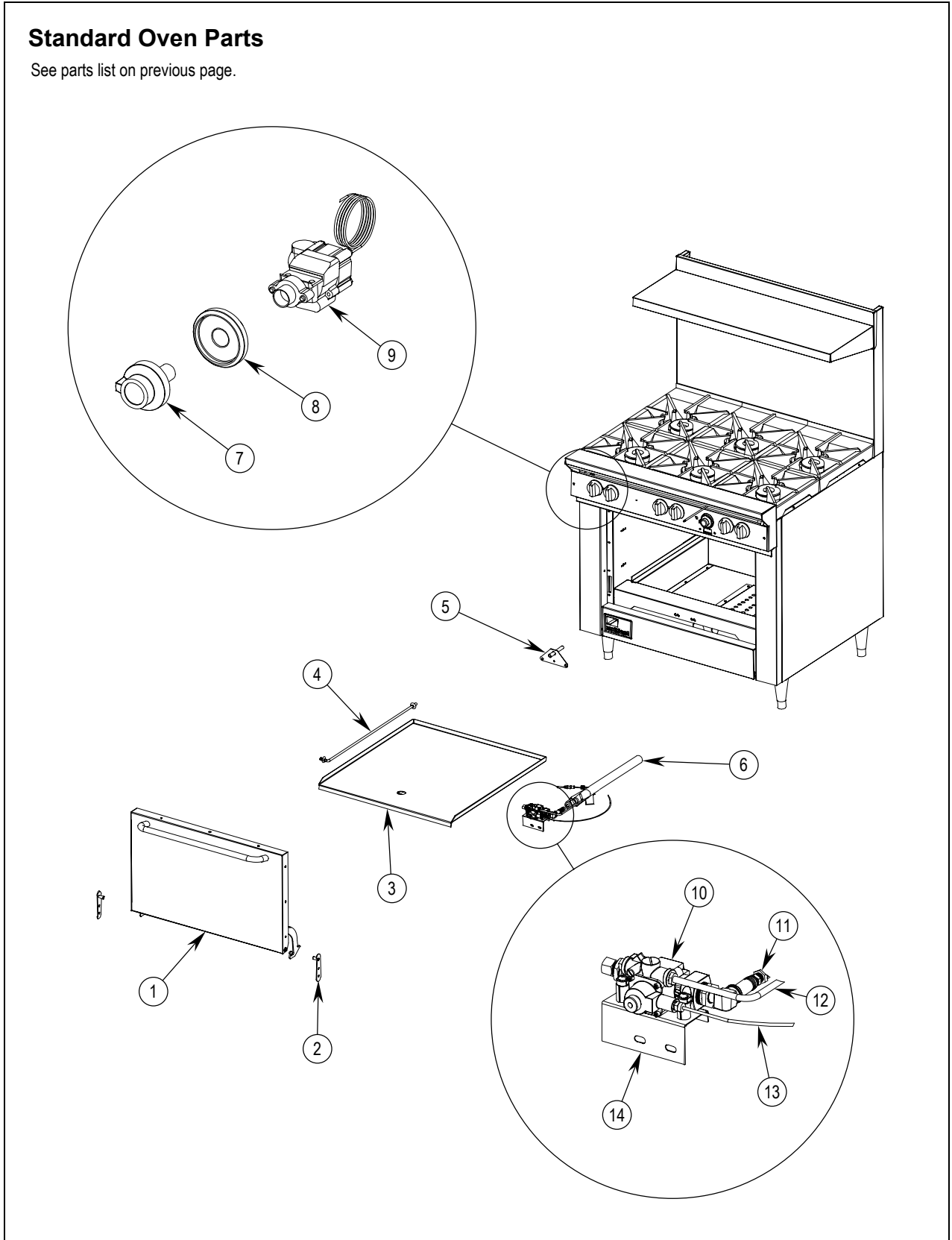

Notes:

MODEL 300 RESTAURANT RANGES

Notes:

Notes:

MODEL 300 RESTAURANT RANGES

Notes:

# SELECT RESTAURANT RANGES



A product with the Southbend name incorporates the best in durability and low maintenance. We all recognize, however, that replacement parts and occasional professional service may be necessary to extend the useful life of this unit. When service is needed, contact a Southbend Authorized Service Agency, or your dealer. To avoid confusion, always refer to the model number, serial number, and type of your unit.



Southbend  
1100 Old Honeycutt Road, Fuquay-Varina, NC 27526  
(919) 552-9161 • FAX (919) 552-9798