

PS300 Series Gas and Electric Ovens

Models:

- PS310
- PS314 (except PS314SBI)
- PS360/360Q/360S
- PS360WB

PARTS MANUAL

for domestic and standard export ovens

© 2000 Middleby Marshall, Inc.2



**Middleby
Marshall®** is a registered trademark of Middleby Marshall, Inc. All rights reserved.

Middleby Cooking Systems Group • 1400 Toastmaster Drive • Elgin, IL 60120 • (847)741-3300 • FAX (847)741-4406

WARNING

FOR YOUR SAFETY DO NOT STORE OR USE GASOLINE OR OTHER FLAMMABLE VAPORS AND LIQUIDS IN THE VICINITY OF THIS OR ANY OTHER APPLIANCE

WARNING

Improper installation, adjustment, alteration, service or maintenance can cause property damage, injury or death. Read the installation, operating and maintenance instructions thoroughly before installing or servicing this equipment.

WARNING

DISCONNECT THE OVEN FROM ITS ELECTRICAL POWER SUPPLY BEFORE SERVICING.

NOTICE

Using any parts other than genuine Middleby Marshall factory manufactured parts relieves² the manufacturer of all warranty and liability.²

NOTICE

Middleby Marshall (Manufacturer) reserves the right to change specifications at any time.²

TABLE OF CONTENTS

<i>Section</i>	<i>Page</i>
.2 KEY SPARE PARTS KIT2.....	4
. INSTALLATIONKIT	5
I.2 OVEN PANELS, WINDOW AND LEGS	6
V.2 SHROUDS AND VENTS2.....	8
V.2 MACHINERY COMPARTMENT	10
V.2 ELECTRICAL COMONENTS2.....	12
VI.2 CONTROL COMPARTMENT	14
VI.2 GAS BURNER SYSTEM (GAS OVENS ONLY)	16
X.2 ELECTRIC HEATERS (ELECTRIC OVENS ONLY)	18
X.2 ELECTRICAL PANEL (ELECTRIC OVENS ONLY)	20
X.2 CONVEYOR ASSEMBLY, SINGLE-BELT OVENS2.....	
XI.2 CONVEYOR ASSEMBLY, SPLIT-BELT OVENS2.....	24
XI.2 UPPER OVEN STAND2.....	26

NOTE: Throughout this Parts Manual, the following abbreviations are used:

A/R = Quantity As Required

N/A = Does Not Apply

I. KEY SPARE PARTS KIT

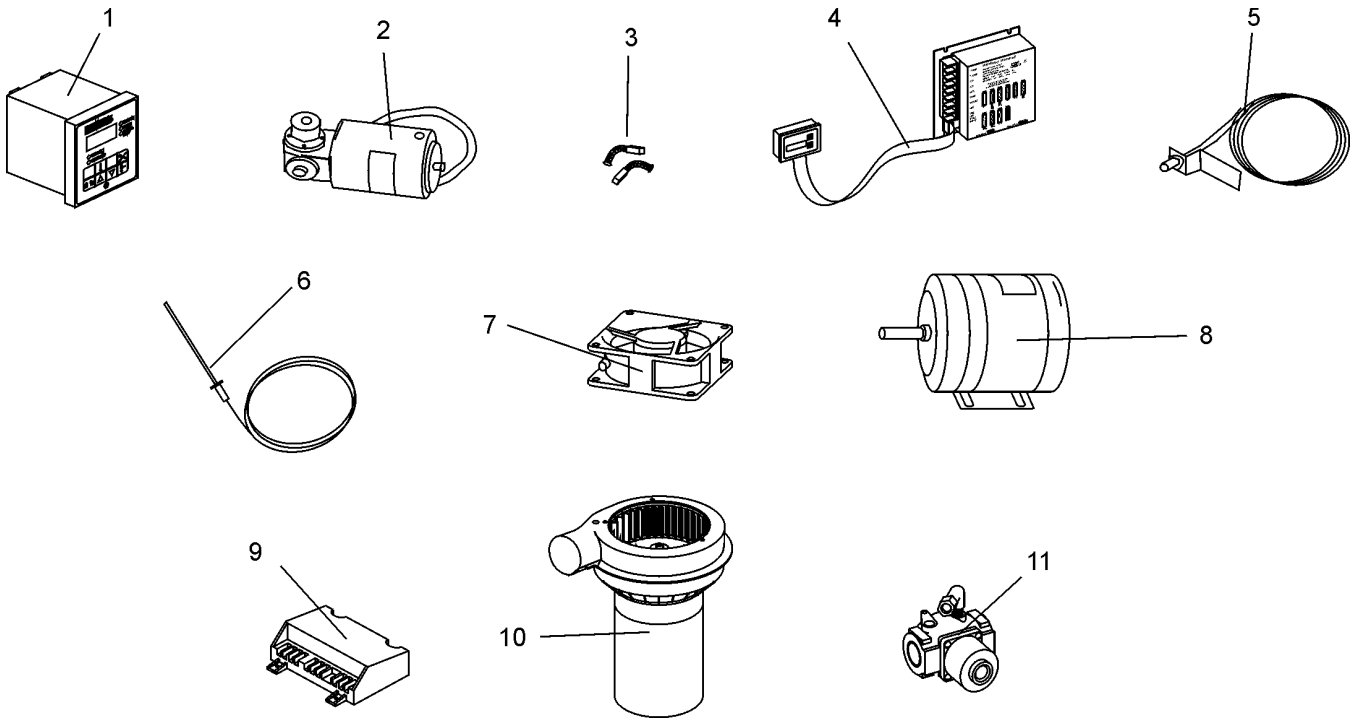

ITEM	QTY.	P/N	DESCRIPTION
1	1	36939	KIT, DIGITAL TEMPERATURE CONTROLLER
2	1	27384-0008	CONVEYOR DRIVE MOTOR
3	2	22450-0052	BRUSHES, CONVEYOR DRIVE MOTOR
4	1	37337	KIT, CONVEYOR SPEED CONTROLLER WITH DIGITAL DISPLAY
5	1	27170-0263	CONVEYOR CONTROL PICKUP ASSEMBLY
6	1	33984	THERMOCOUPLE
7	1	27392-0002	COOLING FAN
8a	1	27381-0023	BLOWER MOTOR, 1 PH, 1/3 HP (PS310, 314, 360, 360S)
8b	1	27381-0024	BLOWER MOTOR, 3 PH, 1/3 HP (PS310, 314, 360)
8c	1	27381-0054	BLOWER MOTOR, 1 PH, 1/4 HP (PS360Q)
8d	1	27381-0075	BLOWER MOTOR, 1 PH, 1/2 HP (PS360WB)

ADDITIONAL KIT COMPONENTS FOR GAS OVENS

9	1	42810-0114	KIT, IGNITION MODULE
10	1	27170-0011	BURNER BLOWER/MOTOR ASSEMBLY
11	1	28091-0017	SOLENOID VALVE

II. INSTALLATION KIT

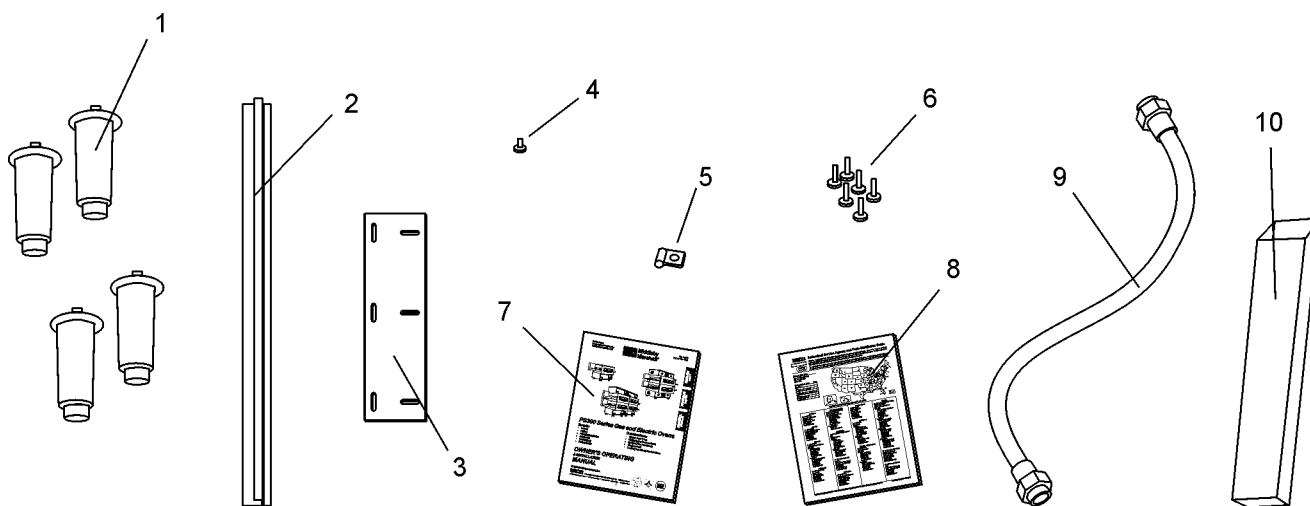

ITEM	QTY.			P/N	DESCRIPTION
	LWR OVEN W/O TOP	LWR OVEN W/TOP	UPR OVEN		
1(4(4(--	22450-0028(LEGS, ADJUSTABLE(
2a(1(1(1(35000-1099(CONVEYOR END STOP, PS310/314(
2b(1(1(1(35000-1103(CONVEYOR END STOP, PS360/360S SINGLE BELT(
2c(2(2(2(35509(CONVEYOR END STOP, PS360/360S SPLIT BELT(
2d(1(1(1(37000-0524(CONVEYOR END STOP, PS360Q(
2e(1(1(1(36526(CONVEYOR END STOP, PS360WB (SINGLE OR SPLIT BELT)(
3(--	--	2(35122-0049(ATTACHMENT PLATE, UPPER OVEN(
4(2(2(2(21256-0008(SCREW, #10-32 X 3/8"(
5(1(1(1(27276-0001(CABLE CLAMP(
6	2(2(14(21292-0001(SCREW, #2PT 10-16 X 3/4" HWH(
7(1(1(1(41823(OWNER'S OPERATING AND INSTALLATION MANUAL(
8(1(1(1(1002040(AUTHORIZED SERVICE AGENCY LISTING(

ADDITIONAL KIT COMPONENTS FOR GAS OVENS

4(1(1(1(21256-0008(SCREW, #10-32 X 3/8"(
6	2(2(2(21292-0001(SCREW, #2PT 10-16 X 3/4" HWH(
9(1(1(1(22361-0001(GAS HOSE, FLEXIBLE(
10a(--	1(--	30773(FLUE VENT, 14" (356mm)(
10b(--	--	1(30759(FLUE VENT, 29-1/2" (749mm)(
10c(1(--	--	30758(FLUE VENT, 50" (1270mm)(

ADDITIONAL KIT COMPONENTS FOR TANDEM OVENS (NOT SHOWN)

ITEM	TANDEM OVEN	DOUBLE (2-STACK) TANDEM OVEN	P/N	DESCRIPTION
--	1(2(35000-1454(MACHINERY COMPARTMENT TRIM STRIP(
--	2(4(35000-1456(FRONT GASKET SPACER(
--	2(4(35000-1457(REAR GASKET SPACER(
--	1(2(37200-0013(BAKING CHAMBER GASKET AND FRAME, PS360(
--	1(2(32483(BAKING CHAMBER GASKET AND FRAME, PS360WB(

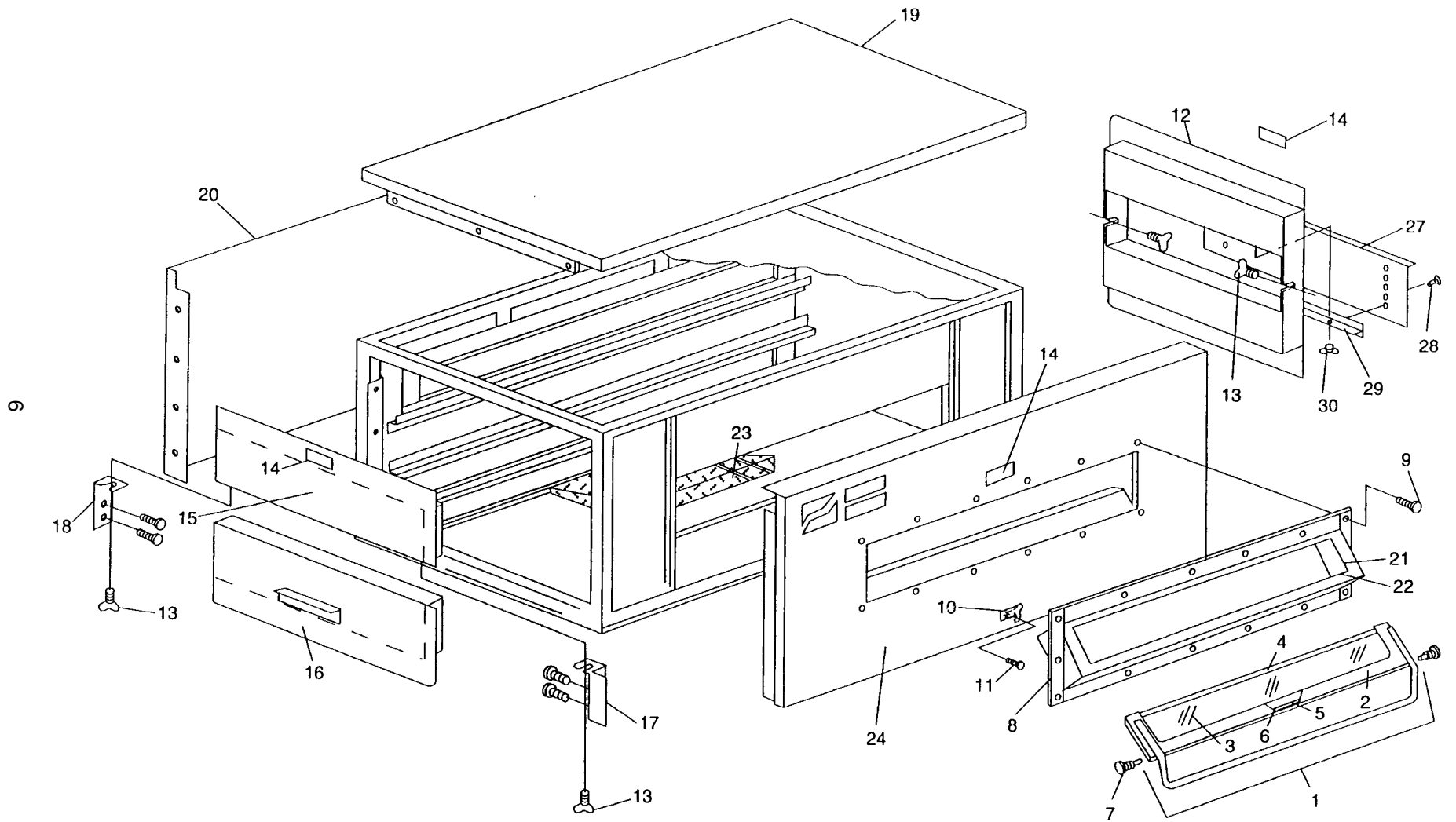

III. OVEN PANELS, WINDOWS, AND LEGS

ITEM QTY.	PS310/314	P/N		DESCRIPTION	
		PS360	PS360WB		
1	1	42400-0156	42400-0156	42400-0156	GLASS FRAME/HANDLE ASSEMBLY
2	1	37115-0136	37115-0136	37115-0136	GLASS FRAME/HANDLE WELDMENT
3	1	22140-0012	22140-0012	22140-0012	GLASS
4	1	35000-1025	35000-1025	35000-1025	TOP FRAME
5	A/R	17130-0006	17130-0006	17130-0006	SILICONE - ADH. SEAL
6	1	33300-0114	33300-0114	33300-0114	TUBE SS. 18 GA. 37" X 3/8"
7	2	34121-0003	34121-0003	34121-0003	SCREW - THUMB PIVOT
8	1	37000-0371	37000-0371	37000-0371	WINDOW/MTG FRAME WELDMENT
9	14	31451	31451	31451	SCREW 6/32 X 5/8"
10	1	42400-0087	42400-0087	42400-0087	LATCH ASSEMBLY
12a	1	37000-0462	37000-0454	37000-0740 or 34309	END PLUG - RIGHT, UPPER OVEN
12b	1	37000-0463	37000-0455	37000-0739 or 34433	END PLUG - RIGHT, LOWER OVEN
13	4	31409	31409	31409	WING SCREW
14	3	30631	30631	30631	CAUTION LABEL
15a	1	37000-0464	37000-0456	37000-0738 or 34310	END PLUG TOP HALF - LEFT, UPPER OVEN
15b	1	37000-0466	37000-0458	37000-0736 or 34431	END PLUG TOP HALF - LEFT, LOWER OVEN
16a	1	37000-0465	37000-0457	37000-0737 or 34314	END PLUG BOTTOM HALF - LEFT, UPPER OVEN
16b	1	37000-0467	37000-0459	37000-0735 or 34430	END PLUG BOTTOM HALF - LEFT, LOWER OVEN

ITEM QTY.	PS310/314	P/N		DESCRIPTION	
		PS360	PS360WB		
17	1	35000-0946	35000-0946	35000-1834	END PLUG BRACKET - LH FRONT
18	1	35000-0945	35000-0945	35000-1833	END PLUG BRACKET - LH REAR
19a	1	35000-1494	35000-1493	35000-1898	TOP PANEL (LOWER SINGLE OVEN - FITS ON TOP OF BAKING CHAMBER)
19b	1	35000-0063	35000-0063	35000-1894	TOP PANEL (UPPER OVEN OR DOUBLE OVEN - MOUNTS ON TOP OF MACHINERY COMPARTMENT)
20	1	37000-0451	37000-0451	37000-0451	REAR PANEL
21	A/R	22420-0005	22420-0005	22420-0005	WINDOW GASKET
23	1	35200-0010	35200-0010	35200-0010	SCREEN GUARD FOR UPPER BURNER CHAMBER (OPTIONAL)
24a	1	35000-0955	35000-0955	35000-0955	FRONT PANEL, OUTER, LOWER OVEN
24b	1	35000-0953	35000-0953	35000-0953	FRONT PANEL, OUTER, UPPER OVEN
26	A/R	22131-0004	22131-0004	22131-0004	INSULATION 1" INSIDE OF ALL TOP, FRONT AND REAR PANELS (NOT SHOWN)
27	1	35200-0034	35200-0034	35200-0034	EYEBROW
28	2	21141-0001	21141-0001	21141-0001	WING NUT, 1/4"-20
29	1	37000-0571	37000-0571	37000-0571	EYEBROW MOUNTING BRACKET
30	2	21292-0001	21292-0001	21292-0001	SCREW, HEX WASHER HEAD #2 PT, #10-16 x 3/4"

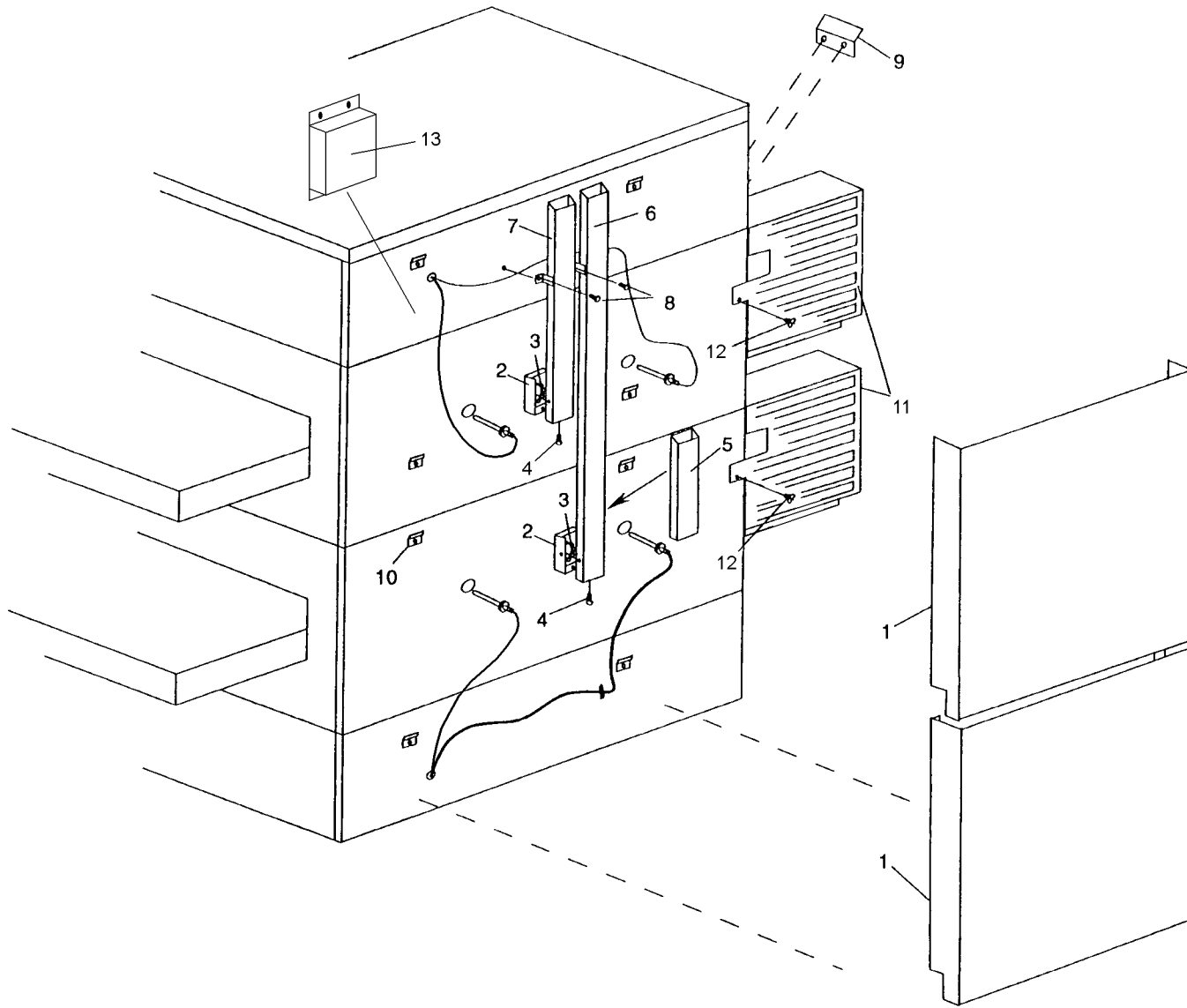
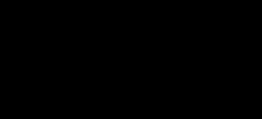

IV. SHROUDS AND VENTS

ITEM	QTY. SINGLE OVEN	QTY. DOUBLE OVEN	P/N	DESCRIPTION
1a	1	2	31495	FLUEVENTSHROUD, 2" (51mm)
1b	1	2	32137	FLUE VENT SHROUD, 5" (127mm)
2	1	2	30758	VENT MOUNTING BOX
3	1	2	27280-0005	NUT
4	2	4	21256-0008	SCREW, HEX HD #10-32 X 3/8"
5	1	-	30773	VENT, 14" (356mm) - FOR LOWER OVENS
6	-	1	30760	VENT, 50" (1270mm) - FOR LOWER OVENS
7	1	1	30759	VENT, 29-1/2" (749mm) - FOR UPPER OVENS
8	2	4	21292-0001	SCREW, HEX HD #10-16 X 3/4"
9	1	2	35000-1017	UTILITY SHROUD HANGER
10	4	8	35000-1622	HANGER, REAR SHROUD

ITEM	QTY. SINGLE OVEN	QTY. DOUBLE OVEN	P/N	DESCRIPTION
11a	1	2	42400-0274	UTILITY SHROUD, STD, 19-5/8" HIGH - SINGLE-BELT OVENS
11b	1	2	42400-0316	UTILITY SHROUD, SPECIAL, 17-5/8" HIGH - SINGLE-BELT OVENS
11c	1	2	42400-0361 or 34339	UTILITY SHROUD, STD, 19-5/8" HIGH - SPLIT-BELT OVENS
11d	1	2	42400-0525	UTILITY SHROUD, SPECIAL, 17-5/8" H - SPLIT-BELT OVENS
12	1	2	21298-0002	WING SCREW 1/4"-20 X 1/2"
13a	1	2	28082-0010	TRANSFORMER, 0.75 KVA
13b	1	2	28082-0011	TRANSFORMER, 1.00 KVA
13c	1	2	42810-0086	KIT, TRANSFORMER, TO OPERATE OVEN ON 110V SUPPLY
-	-	-	28082-0016	TRANSFORMER, 2.00 KVA - INCLUDED WITH KIT 42810-0086

6

V. MACHINERY COMPARTMENT

ITEM	QTY.	P/N	DESCRIPTION
1(1(37000-0450(MACHINERY COMPARTMENT DOOR(
2(1(37000-0449(CONTROL COMPARTMENT DOOR(
3(4(2000294(FLAT HEAD SCREW, #10-24 x 1-1/4"(
4(18(21475-0001(FINISHING WASHER, #10(
5(4(30338(RETAINER, #10-24(
6	6	21292-0001(HEX SCREW, #10-16 X 3/4"(
7(4(37115-0102(CASTER(
8(4(22450-0028(ADJUSTABLE LEG(
9(14(21272-0013(FLAT HEAD SCREW, #10-24 X 1/2"(
10a(1(35000-0958(END PANEL - RIGHT SIDE FOR LOWER OVEN, LEFT SIDE(
			FOR UPPER OVEN - PS310/314/360(
10b(1(35000-1866(END PANEL - RIGHT SIDE FOR LOWER OVEN, LEFT SIDE(
			FOR UPPER OVEN - PS360WB(
11a(1(35000-0959(END PANEL - LEFT SIDE FOR LOWER OVEN, RIGHT SIDE(
			FOR UPPER OVEN - PS310/314/360(
11b(1(35000-1867(END PANEL - LEFT SIDE FOR LOWER OVEN, RIGHT SIDE(
			FOR UPPER OVEN - PS360WB(
12(1(28021-0047(DOOR SAFETY SWITCH(
13(1(35000-0957(REAR PANEL, MACHINERY COMPARTMENT(

ITEM	QTY.	P/N	DESCRIPTION
14a(2(27381-0023(BLOWER MOTOR, 1 PH, 1/3 HP (PS310, 314, 360, 360S)(
14b(2(27381-0024(BLOWER MOTOR, 3 PH, 1/3 HP (PS310, 314, 360)(
14c(2(27381-0054(BLOWER MOTOR, 1 PH, 1/4 HP (PS360Q)(
14d(2(27381-0075(BLOWER MOTOR, 1 PH, 1/2 HP (PS360WB)(
--	1 oz.(17110-0018(TUBE OF ANTI-SEIZE LUBRICANT (NOT SHOWN)(
15(2(27221-0013(BUSH, SNAP NYLON(
16	8(21216-0013(HEX CAP SCREW, 5/16"-18 X 1"(
17(16	21412-0005(FLAT WASHER, 5/16"(
18(8(21126-0004(HEX NUT, 5/16"-18(
19(2(27396-0004(HEAT SLINGER WITH SET SCREW(
20(1(21276-0035(SET SCREW, 1/4"-20 X 3/8"(
21(2(22450-0062(INLET CONE, 9-3/16"(
22a(1(22523-0002(CLOCKWISE BLOWER WHEEL, 9-3/16" D - LEFT SIDE OF(
			LOWER OVEN, RIGHT SIDE OF UPPER OVEN(
22b(1(22523-0003(COUNTERCLOCKWISE BLOWER WHEEL, 9-3/16" D - RIGHT(
			SIDE OF LOWER OVEN, LEFT SIDE OF UPPER OVEN(
23(2(37115-0151(INNER SHAFT SEAL(
24(2(35000-1781(TEFLON SEAL(
25(2(35131-0038(HEAT SINK PLATE(
26	A/R(21292-0001(HEX SCREW, #10-16 X 3/4"(
27(A/R(22420-0002(GASKET (PER FOOT)(

ADDITIONAL COMPONENTS FOR GAS OVENS

ITEM	QTY.	P/N	DESCRIPTION
28(1(35000-1036(BURNER OUTER MOUNTING PLATE(
29(1(37000-0236(BURNER INNER MOUNTING PLATE(
30(1(35112-0075(BURNER TUBE(
31(1(37000-0659(ADJUSTABLE FLAME TUBE(

ITEM	QTY.	P/N	DESCRIPTION
32(1(35333-0003(BURNER SHIELD(
33(1(37000-0658(ADJUSTABLE FLAME TUBE INDICATOR AND SHAFT(
34(A/R(21292-0001(HEX SCREW, #10-16 X 3/4"(

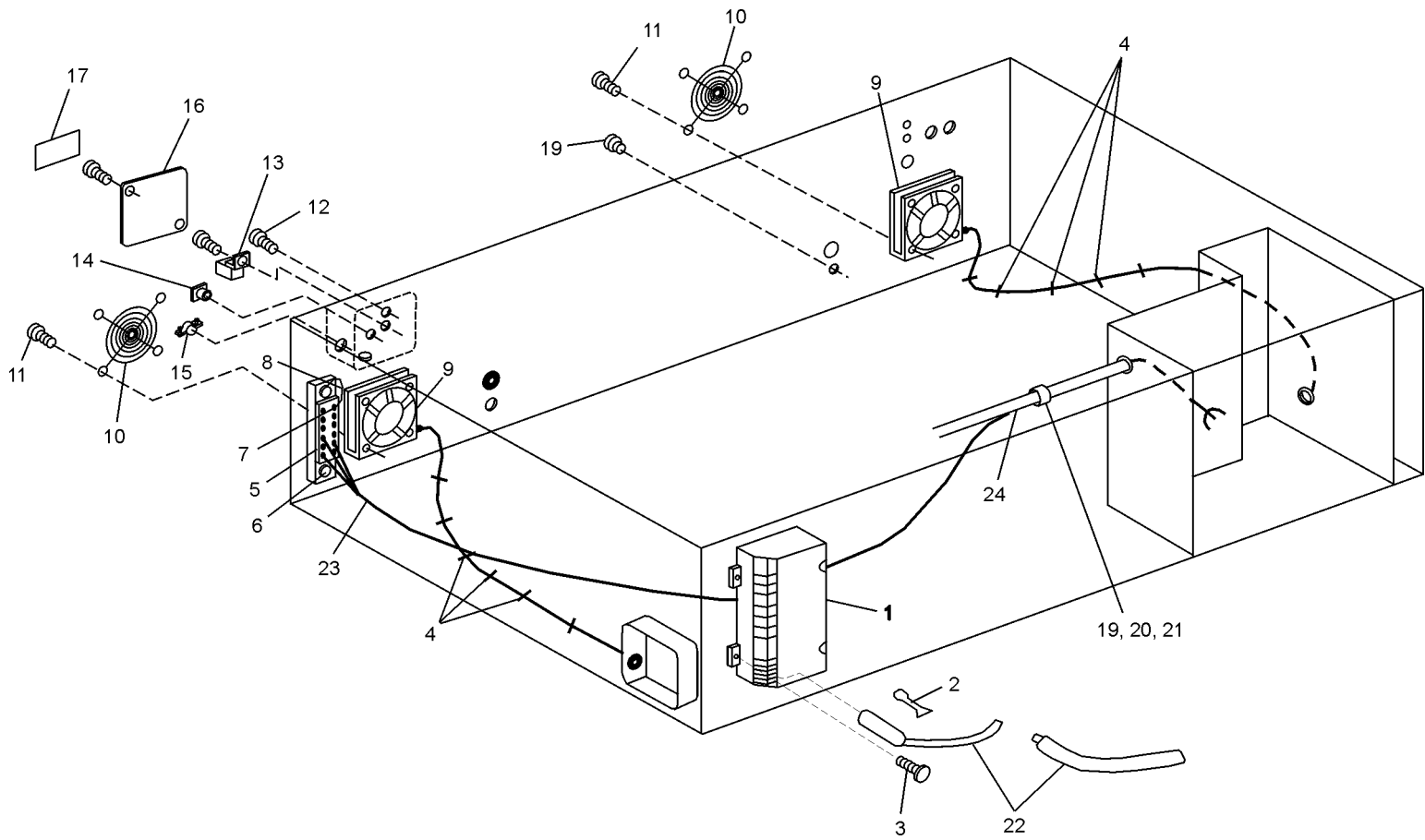
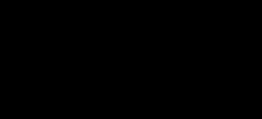

VI. ELECTRICAL COMPONENTS

<i>ITEM</i>	<i>QTY.</i>	<i>P/N</i>	<i>DESCRIPTION</i>
1	1	42810-0114	KIT, IGNITION MODULE (WITH ADAPTER - GAS OVENS)
2	1	27161-0006	ADAPTER, IGNITION MODULE
3	3	21278-0007	SCREW, SLT RND HD #8-32 x 1-1/8"
4	A/R	27311-0002	CABLE TIE, PLASTIC
5	1	27011-0013	TERMINAL BLOCK
6	2	21278-0002	SCREW, SLT RND HD #8-32 x 3/4"
7	A/R	27255-0008	DISCONNECT
8	1	42400-0256	ASSEMBLY, GROUND WIRE
9	2	27392-0002	COOLING FAN
-	2	27159-0003	CORDSET, COOLING FAN
10	2	27470-0004	GRILLE, COOLING FAN
11	8	21226-0007	SCREW, SLT PAN HD #10-24 x 1/2"
12	A/R	21292-0001	SCREW, HEX WSHR HD #10-16 x 3/4"
13	A/R	15028707	TERMINAL, LUG #6-14

<i>ITEM</i>	<i>QTY.</i>	<i>P/N</i>	<i>DESCRIPTION</i>
14	1	27321-0009	STRAIN RELIEF
15	1	27082-0008	CABLE CONNECTOR, STRAIGHT, CLAMP TYPE
16	1	27304-0001	COVER, JUNCTION BOX
17	1	22500-0042	LABEL, "CAUTION HIGH LEG"
18	5	23035-0001	PLUG, PLASTIC, 1/8"
19	2	21221-0015	SCREW, SLT RND HD 1/4"-20 x 3/4"
20	2	B301A8817	NUT, 1/4"-20 HEX
21	4	27276-0002	NYLON CABLE CLAMP
22a	1	27159-0019	IGNITION CABLE, 34" (CURRENT - GAS OVENS)
22b	1	27159-0012	IGNITION CABLE, 30" (ORIGINAL DESIGN - GAS OVENS)
23	1	42400-0334	SHIELDED PICKUP, CONVEYOR CABLE
24	1	42400-0459	WIRING HARNESS (GAS OVENS)

13

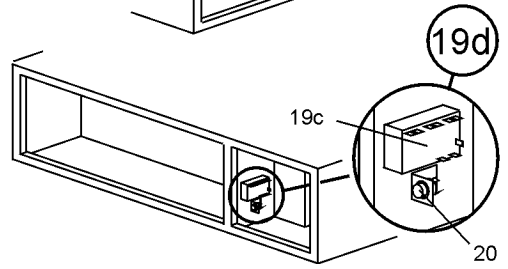
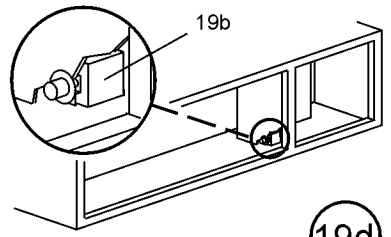
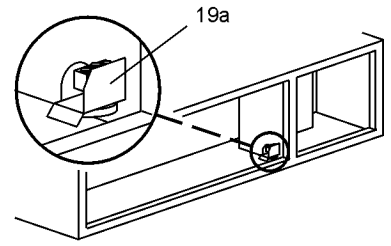
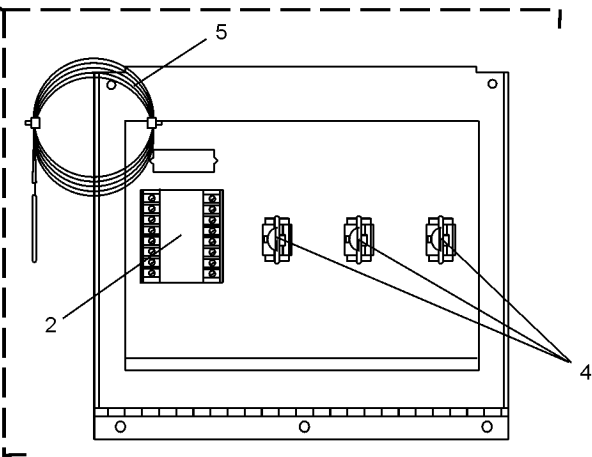
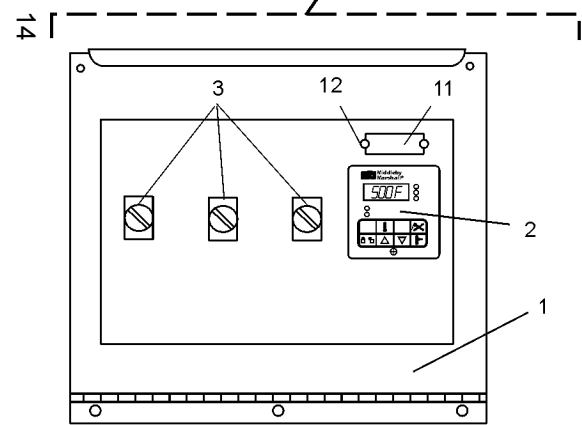
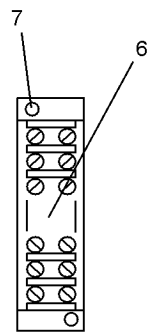
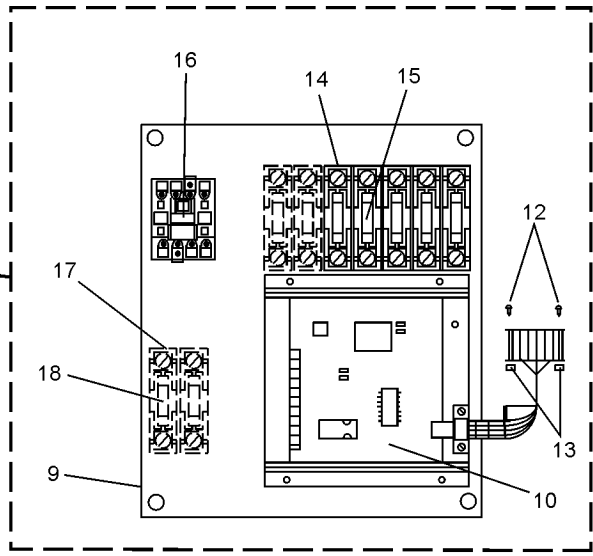
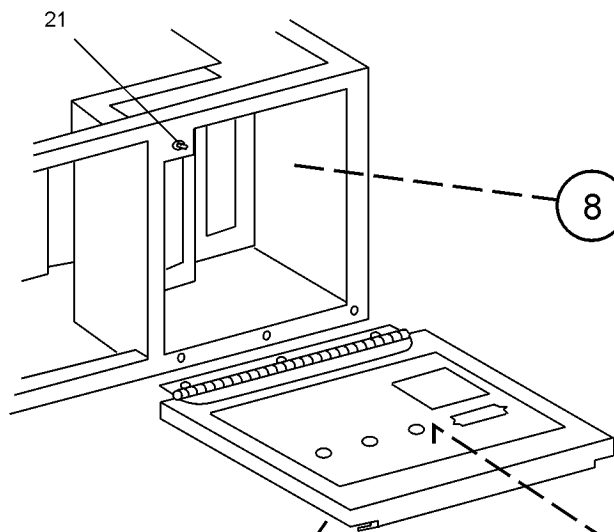

VII. CONTROL COMPARTMENT

<i>ITEM</i>	<i>QTY.</i>	<i>P/N</i>	<i>DESCRIPTION</i>
1	1	37000-0449	PANEL, CONTROL DOOR (WITHOUT COMPONENTS)
2	1	36939	KIT, TEMPERATURE CONTROLLER
3	3	28021-0062	SELECTOR SWITCH, 2-POSITION, BLUE
4	3	27060-0012	CONTACT BLOCK WITH BASE
5	2	33984	KIT, THERMOCOUPLE
6	1	27011-0011	TERMINAL BLOCK, 8-POLE, 30A, 600V
7	2	21281-0004	SCREW, PHL PAN HD #8 x 5/8"
8a	1	42400-0273S	COMPONENT PANEL ASSEMBLY - GAS OVENS, WIRED - INCLUDES ITEMS 9-16
8b	1	34710	COMPONENT PANEL ASSEMBLY - 208V/240V ELECTRIC OVENS, WIRED - INCLUDES ITEMS 9-16
8c	1	42400-0300	COMPONENT PANEL ASSEMBLY - 380/415/480V ELECTRIC OVENS, WIRED - INCLUDES ITEMS 9-18
9	1	35232-0010	PANEL (WITHOUT COMPONENTS)
10	1	37337	KIT, CONVEYOR SPEED CONTROLLER WITH DIGITAL DISPLAY
11	1	37503	DIGITAL DISPLAY ONLY
12	2	21278-0003	SCREW, SLT RND HD #4-40 x 1/4"
13	2	21126-0010	HEX NUT, #4-40
14a	1	27021-0011	FUSE BLOCK, 5P CLASS "M" (GAS OVENS)
14b	1	27021-0013	FUSE BLOCK, 7P CLASS "CC" (ELECTRIC OVENS)

15

<i>ITEM</i>	<i>QTY.</i>	<i>P/N</i>	<i>DESCRIPTION</i>
15a	5	28154-0013	FUSE, MIDGET "CC" 15A 600V (GAS OVENS)
15b	7	28154-0013	FUSE, MIDGET "CC" 15A 600V (ELECTRIC OVENS)
16a	1	28041-0008	CONTACTOR, 4P 25A 120V (GAS OVENS)
16b	2	28041-0008	CONTACTOR, 4P 25A 120V (ELECTRIC OVENS)
17	1	27021-0012	FUSE BLOCK, 2P CLASS "M" (480V ELECTRIC OVENS ONLY)
18	2	28154-0005	FUSE, MIDGET TIME DELAY 5A 600V (480V ELECTRIC OVENS ONLY)
19a	1	28074-0002 <i>NO LONGER AVAILABLE. USE ITEM 19d</i>	HIGH LIMIT CONTROL MODULE, UNITED ELECTRIC TYPE 54 (EARLY GAS AND ELECTRIC OVENS)
19b	1	28071-0014 <i>LIMITED AVAILABILITY. IF UNAVAILABLE USE ITEM 19d</i>	HIGH LIMIT/COOLDOWN CONTROL MODULE, UNITED ELECTRIC TYPE 55 (LATER ELECTRIC OVENS)
19c	1	34982	HIGH LIMIT CONTROL MODULE, WATLOW (CURRENT ELECTRIC OVENS)
19d	-	39733	KIT, HIGH LIMIT CONVERSION - REPLACES ITEM 19a OR 19b WITH ITEM 19c - INCLUDES RESEST SWITCH, ITEM 20
20	1	30693	LIGHTED RESET SWITCH FOR WATLOW HIGH LIMIT, 115V
21	1	28021-0047	DOOR SAFETY SWITCH

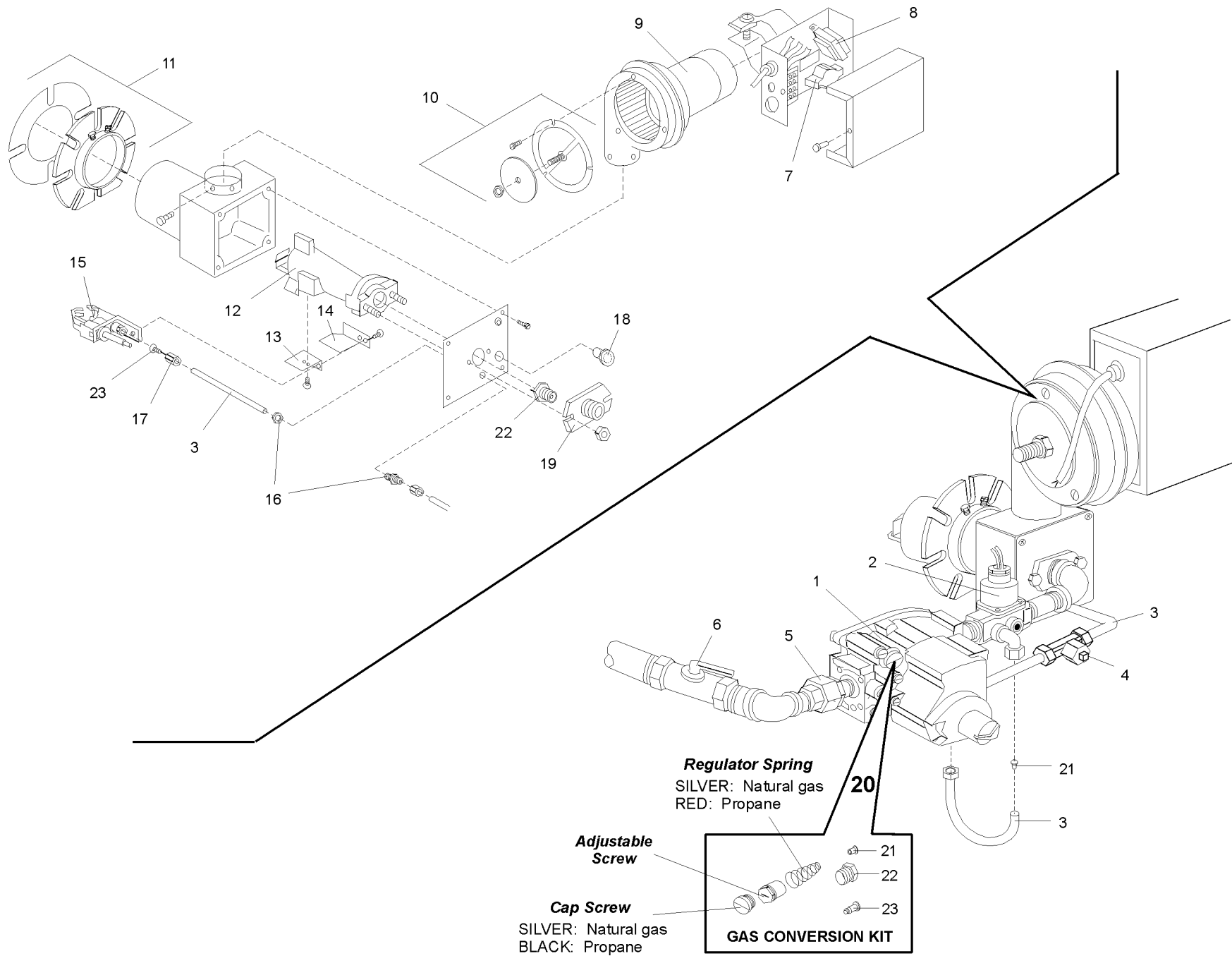

VIII. GAS BURNER SYSTEM (GAS OVENS ONLY)

<i>ITEM</i>	<i>QTY.</i>	<i>P/N</i>	<i>DESCRIPTION</i>
1	1	42810-0121	GAS CONTROL VALVE, 1/2"
2	1	28091-0017	SOLENOID VALVE
3	A/R	15125-0002	TUBING, ALUMINUM, 1/4" DIA., 1 FT.
4	1	30185	KIT, PILOT PRESSURE TAP (PILOT TEE)
5	1	23051-0003	UNION, 1/2"
6	1	23115-0010	GAS VALVE, MANUAL, 3/4" I.D.
7	1	27170-0016	MOTOR RELAY
8	1	27170-0017	TRANSFORMER, 120/240V
9	1	27170-0011	MOTOR, BURNER BLOWER
10	1	42810-0087	KIT, EXTERNAL AIR SHUTTER
11	1	36562	KIT, BURNER MOUNTING RING
12	1	27170-0223	VENTURI ASSEMBLY
13	1	27170-0264	BRACKET, PILOT IGNITOR
14	1	27170-0204	SHIELD, PILOT
15	1	42810-0117	KIT, PILOT IGNITOR ASSEMBLY
16	1	23052-0007	FITTING, PILOT BULKHEAD
17	1	38284	FITTING, PILOT TUBING
18	1	38280	WINDOW PLUG
19	1	38279	MAIN ORIFICE HOLDER/GAS INLET CONNECTOR

17

<i>ITEM</i>	<i>QTY.</i>	<i>P/N</i>			<i>DESCRIPTION</i>
		<i>PS310/314</i>	<i>PS360</i>	<i>PS360WB</i>	
20a	--	42810-0119	42810-0119	42810-0124	KIT, GAS CONVERSION, NATURAL GAS TO PROPANE - INCLUDES ITEMS 21-23 AND INSTRUCTIONS FOR CONVERSION
20d	--	42810-0120	42810-0120	42810-0127	KIT, GAS CONVERSION, PROPANE TO NATURAL GAS - INCLUDES ITEMS 21-23 AND INSTRUCTIONS FOR CONVERSION
21a	1	22174-0006	22174-0006	22174-0006	ORIFICE, BYPASS 0.065"/1.65mm/#53 DRILL - NATURAL GAS
21b	1	22174-0009	22174-0009	22174-0009	ORIFICE, BYPASS 0.034"/0.86mm/#62 DRILL - PROPANE
22a	1	22176-0004	22176-0004	--	ORIFICE, MAIN, 0.219"/5.56mm - NATURAL GAS, PS310/314/360 OVENS
22b	1	--	--	22176-0014	ORIFICE, MAIN, 0.250"/6.35mm - NATURAL GAS, PS360WB OVENS
22c	1	22176-0003	22176-0003	--	ORIFICE, MAIN, 0.134"/3.40mm - PROPANE, PS310/314/360 OVENS
22d	1	--	--	22176-0015	ORIFICE, MAIN, 0.152"/3.86mm - PROPANE, PS360WB OVENS
23a	1	22174-0011	22174-0011	22174-0011	ORIFICE, PILOT, 0.028"/0.71mm - NATURAL GAS
23b	1	22174-0010	22174-0010	22174-0010	ORIFICE, PILOT, 0.018"/0.46mm - PROPANE

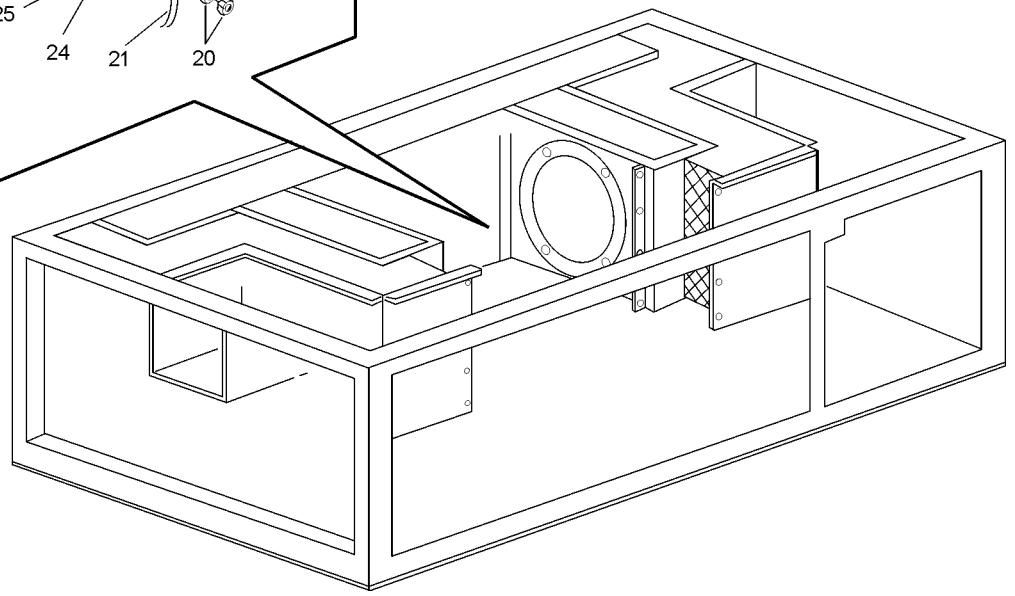
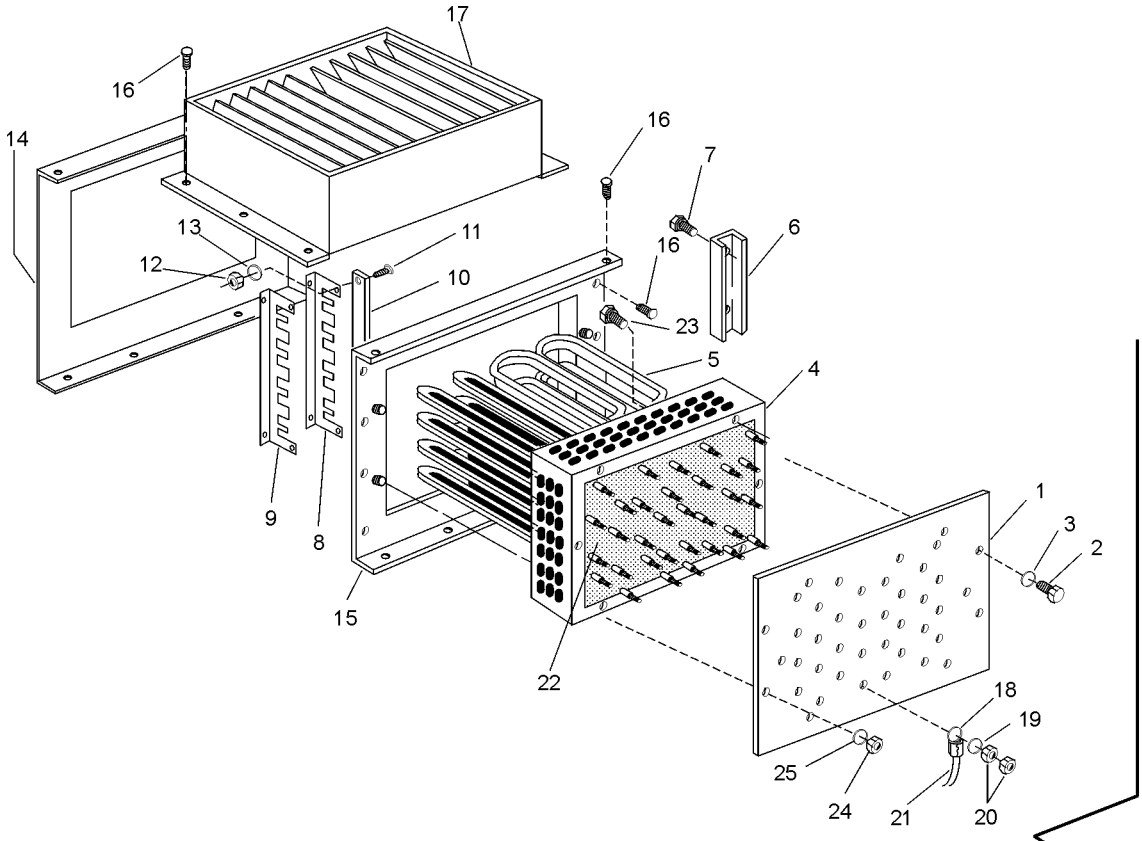

IX. ELECTRIC HEATERS (ELECTRIC OVENS ONLY)

<i>ITEM</i>	<i>QTY.</i>	<i>P/N</i>	<i>DESCRIPTION</i>
-	1	42400-0310	HEATING ELEMENT ASSEMBLY, 208V
-	1	42400-0311	HEATING ELEMENT ASSEMBLY, 240V
-	1	42400-0312	HEATING ELEMENT ASSEMBLY, 380V
-	1	42400-0313	HEATING ELEMENT ASSEMBLY, 415V
-	1	42400-0314	HEATING ELEMENT ASSEMBLY, 480V
1	1	35000-1316	HEATING ELEMENT COVER
2	6	A6153	SCREW, HEX HD 1/4"-20 X 1/2"
3	6	21426-0002	LOCKWASHER, 1/4"
4	1	37000-0562	MOUNTING PLATE, HEATER
5a	18	27374-0001	HEATING ELEMENT, 208V
5b	18	27374-0002	HEATING ELEMENT, 240V/415V/480V
5c	18	27374-0003	HEATING ELEMENT, 380V
6	4	35000-1340	BRACKET HOLDER, HEATING ELEMENT
7	8	A3896	SCREW, HEX HD 5/16"-18 x 1"
8	2	35000-1337	HEATING ELEMENT SPACER (4)
9	2	35000-1338	HEATING ELEMENT SPACER (5)
10	4	35000-1339	HEATING ELEMENT SPACER BAR

<i>ITEM</i>	<i>QTY.</i>	<i>P/N</i>	<i>DESCRIPTION</i>
11	8	21226-0007	SCREW, RND HD #10-24 x 1/2"
12	8	A3323	HEX NUT, 10-24 SS
13	8	21426-0005	LOCKWASHER, #10
14	1	35000-1199	INNER PLATE
15	1	35000-1200	OUTER PLATE
16	36	21292-0001	SCREW, HEX HD #10-16 x 3/4"
17	1	37116-0022	BAFFLE
18	A/R	27252-0005	RING TERMINAL, #12 AWG, 1200°F/649°C
19	A/R	21426-0005	LOCKWASHER, #10
20	A/R	21126-0007	HEX NUT, #10-32
21	A/R	27152-0047	WIRE, STRAND #12 AWG (842°F/450°C)
22	A/R	22134-0002	INSULATION - CERAWOOL, 2" THICK x 24" WIDE
23	8	A3896	SCREW, HEX CAP HD 5/16"-18 X 1"
24	4	21126-0004	HEX NUT, 5/16"-18
25	4	21426-0003	LOCKWASHER, 5/16"

19

X. ELECTRICAL PANEL (ELECTRIC OVENS ONLY)

ITEM	QTY.	P/N	DESCRIPTION
-	1	42400-0200	ASSEMBLY, ELECTRIC PANEL AND ALL COMPONENTS
1	1	35000-0295	ELECTRIC PANEL WITHOUT COMPONENTS
2	3	27021-0016	FUSE BLOCK - 3P, 60A/600V, CLASS "T"
3	3	28041-0016	MERCURY CONTACTOR - 3P, 30A, 120V, 50/60HZ
4	2	27480-0001	POWER DISTRIBUTION BLOCK - 2 POLE
5	10	21281-0004	SCREW, #8 X 5/8" AB PH PAN HD. S/ZN
6	6	21278-0002	SCREW, 8-32 X 3/4", RND HD S1 ZN
7	6	21412-0010	WASHER, FLAT #8
8	3	27352-0003	MARKER, WIRE L1, L2, L3
9	3	27352-0005	MARKER, WIRE C1, C2, C3
10	1	27352-0002	MARKER WIRE LETTERS
11	9	27252-0023	TERMINAL LOCKING SPADE

ITEM	QTY.	P/N	DESCRIPTION
12	8 ft. (2.44m)	27152-0053	WIRE, 18 GA AWM 105C WHITE
13	1 ft. (0.30m)	27152-0053	WIRE, 18 GA AWM 105C WHITE
14	1 ft. (0.30m)	27152-0053	WIRE, 18 GA AWM 105C WHITE
15	8 ft. (2.44m)	27152-0002	WIRE, 16 GA AWM 105C BLUE
16	1 ft. (0.30m)	27152-0049	WIRE, 18 GA AWM 105C BLUE
17	2 ft. (0.61m)	27152-0049	WIRE, 18 GA AWM 105C BLUE
18	3 ft. (0.91m)	27152-0025	WIRE, 10 GA AWM 105C BLACK
19	3 ft. (0.91m)	27152-0025	WIRE, 10 GA AWM 105C BLACK
20	3 ft. (0.91m)	27152-0025	WIRE, 10 GA AWM 105C BLACK
21	4 ft. (1.22m)	27152-0025	WIRE, 10 GA AWM 105C BLACK
22	8 ft. (2.44m)	27152-0001	WIRE, 16 GA AWM 105C BLACK
23	8 ft. (2.44m)	27152-0007	WIRE, 16 GA AWM 105C RED
24a*	9	28150-0134	FUSE - 600V, 40A, CLASS "T"
24b*	9	28154-0002	FUSE - 500V, 30A, CLASS "M"
-	1	22500-0040	LABEL "WARNING FUSE RATING AMPS"

*** IMPORTANT: When replacing fuses, use the part number for the fuseW of the same amperage rating.W**

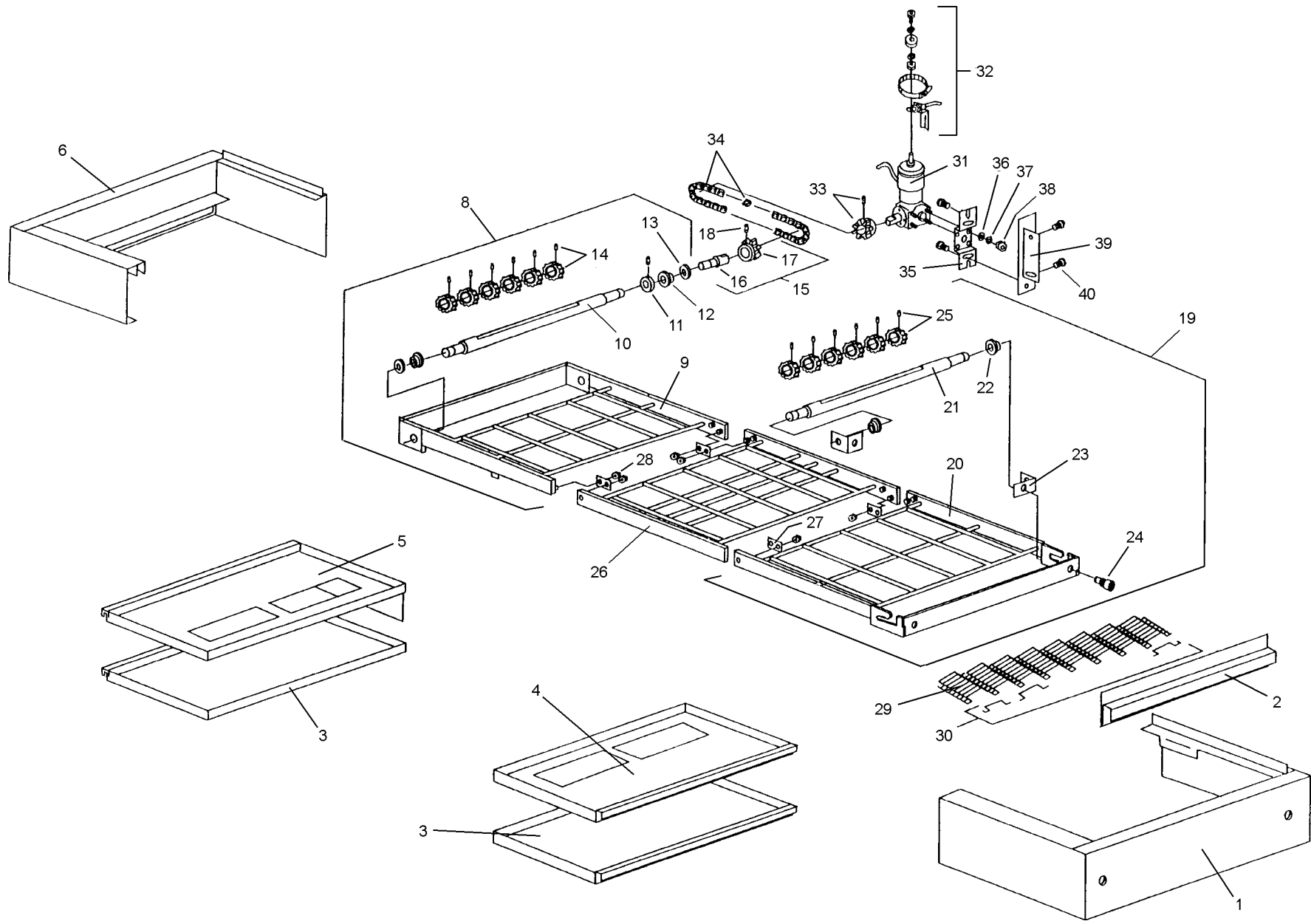

XI. CONVEYOR ASSEMBLY, SINGLE-BELT OVENS

ITEM QTY.	P/N				DESCRIPTION	
	PS310	PS314	PS360	PS360WB		
1	1	37000-0471		37000-0469	37200-0023	COVER, CONVEYOR EXTENSION, IDLER END
2a	1	35000-1099		35000-1103	35000-1899	CONVEYOR END STOP, STD
2b	1	--	--	37000-0524	37000-0524	CONVEYOR END STOP, WIDE - "Q" MODELS ONLY
3	2	35000-1067		35000-0948	35000-1861	CRUMB PAN - ALL SINGLE OVENS, OR LOWER OVEN OF 2-STACK
4	1	35000-1078		35000-1077	35000-1862	CRUMB PAN - UPPER OVEN (IDLER END) OF 2-STACK
5	1	42400-0276		37000-0470	42400-0593	CRUMB PAN WITH HEAT DIVERTER - UPPER OVEN (DRIVE END OF 2-STACK)
6	1	37000-0472		37000-0470	37000-0025	COVER, CONVEYOR EXTENSION, DRIVE END
7	1	42400-0285	35241	42400-0284	42400-0594	CONVEYOR ASSEMBLY, COMPLETE (WITH BELT)
8	1	42400-0281	42400-0440	42400-0283	42400-0595	CONVEYOR ASSEMBLY - DRIVE
9	1	37000-0438	37000-0670	37000-0408	37200-0026	CONVEYOR FRAME - DRIVE
10	1	35000-1072	35000-1072	35000-1012	35000-1864	CONVEYOR DRIVE SHAFT
11	2	22011-0013	22011-0013	22011-0013	22011-0013	SHAFT COLLAR W/SCREW
12	2	22034-0003	22034-0003	22034-0003	22034-0003	BUSHING, 5/8" ID X 3/4" OD X 1/2" LONG
13	1	35000-1080	35000-1080	35000-1080	35000-1080	NYLON SPACER
14a	5	22229-0003	22229-0003	--	--	CONVEYOR SPROCKET WITH SET SCREW
14b	6	--	--	22229-0003	22229-0003	CONVEYOR SPROCKET WITH SET SCREW
--	A/R	21276-0039	21276-0039	21276-0039	21276-0039	SOCKET SET SCREW, 1/4"-28 X 3/8"
15	1	42400-0309	42400-0309	42400-0309	42400-0309	DRIVE SPROCKET ASSY
16	1	35000-1013	35000-1013	35000-1013	35000-1013	DRIVE SHAFT ADAPTER
17	1	22152-0017	22152-0017	22152-0017	22152-0017	SPROCKET, 9T
18	1	21276-0038	21276-0038	21276-0038	21276-0038	SOCKET SET SCREW, #10-24 X 5/16"
19	1	42400-0280	42400-0441	42400-0282	42400-0596	CONVEYOR ASSEMBLY - IDLER
20	1	37000-0437	37000-0671	37000-0409	37200-0027	CONVEYOR FRAME - IDLER
21	1	35000-1071	35000-1071	35000-1011	35000-1865	CONVEYOR IDLER SHAFT
22	2	22034-0003	22034-0003	22034-0003	22034-0003	BUSHING, 5/8" ID X 3/4" OD X 1/2" LONG
23	2	37000-0413	37000-0413	37000-0413	37000-0413	TENSION ADJUSTMENT BRACKET
24	2	35000-1008	35000-1008	35000-1008	35000-1008	TENSION ADJUSTMENT BOLT
25a	5	22229-0003	22229-0003	--	--	CONVEYOR SPROCKET WITH SET SCREW
25b	6	--	--	22229-0003	22229-0003	CONVEYOR SPROCKET WITH SET SCREW
--	A/R	21276-0039	21276-0039	21276-0039	21276-0039	SOCKET SET SCREW, 1/4"-28 X 3/8"

ITEM QTY.	P/N				DESCRIPTION	
	PS310	PS314	PS360	PS360WB		
26a	1	37000-0436	--	37000-0410	37200-0028	CONVEYOR FRAME - CENTER, STANDARD
26b	2	--	--	37000-0635	33293	CONVEYOR FRAME - CENTER, TANDEM OVENS
27	A/R	35900-0169	35900-0169	35900-0169	35900-0169	CONVEYOR PIVOT PLATE
28	A/R	21176-0001	21176-0001	21176-0001	21176-0001	HEX LOCK NUT, 1/4"-20
29a	1	22450-0009	22450-0009	22450-0001	22450-0289	CONV. BELT, COMPLETE 174"L
29b	--	33900-0035	33900-0035	33900-0032	33900-0085	BELT SECTION, 12"L
30	1	42400-0090	42400-0090	42400-0089	42400-0598	MASTER LINKS KIT
31	1	27384-0008	27384-0008	27384-0008	27384-0008	GEAR MOTOR, 1400:1
--	2	22450-0052	22450-0052	22450-0052	22450-0052	BRUSHES, GEAR MOTOR
32	1	27170-0263	27170-0263	27170-0263	27170-0263	PICKUP ASSEMBLY
33a	1	22152-0018	22152-0018	22152-0018	22152-0018	SPROCKET, STANDARD - 15T WITH SET SCREW
33b	1	--	--	22152-0027	--	SPROCKET, HIGH SPEED OPTION - 45T WITH SET SCREW
33c	1	--	--	22152-0022	22152-0022	SPROCKET, TANDEM OVEN - 30T WITH SET SCREW
34a	1	42400-0163	42400-0163	42400-0163	42400-0163	ROLLER CHAIN ASSY - STANDARD, 52 LINKS, 25-1/2", WITH MASTER LINK
34b	1	--	--	42400-0164	42400-0164	ROLLER CHAIN ASSY - TANDEM OVENS, 62 LINKS, 30-1/2", WITH MASTER LINK
35	1	35000-1021	35000-1021	35000-1021	35000-1021	MOTOR MOUNTING BRACKET
36	4	21411-0003	21411-0003	21411-0003	21411-0003	FLAT WASHER, 1/4"
37	4	21426-0002	21426-0002	21426-0002	21426-0002	LOCKWASHER, 1/4"
38	4	21126-0009	21126-0009	21126-0009	21126-0009	HEX NUT, 1/4"-20
39	1	37000-0427	37000-0427	37000-0427	37000-0427	MOTOR MOUNTING WELDMENT
40	4	21212-0002	21212-0002	21212-0002	21212-0002	SCREW, CAP HEX HD 1/4"-20 X 3/4"

23

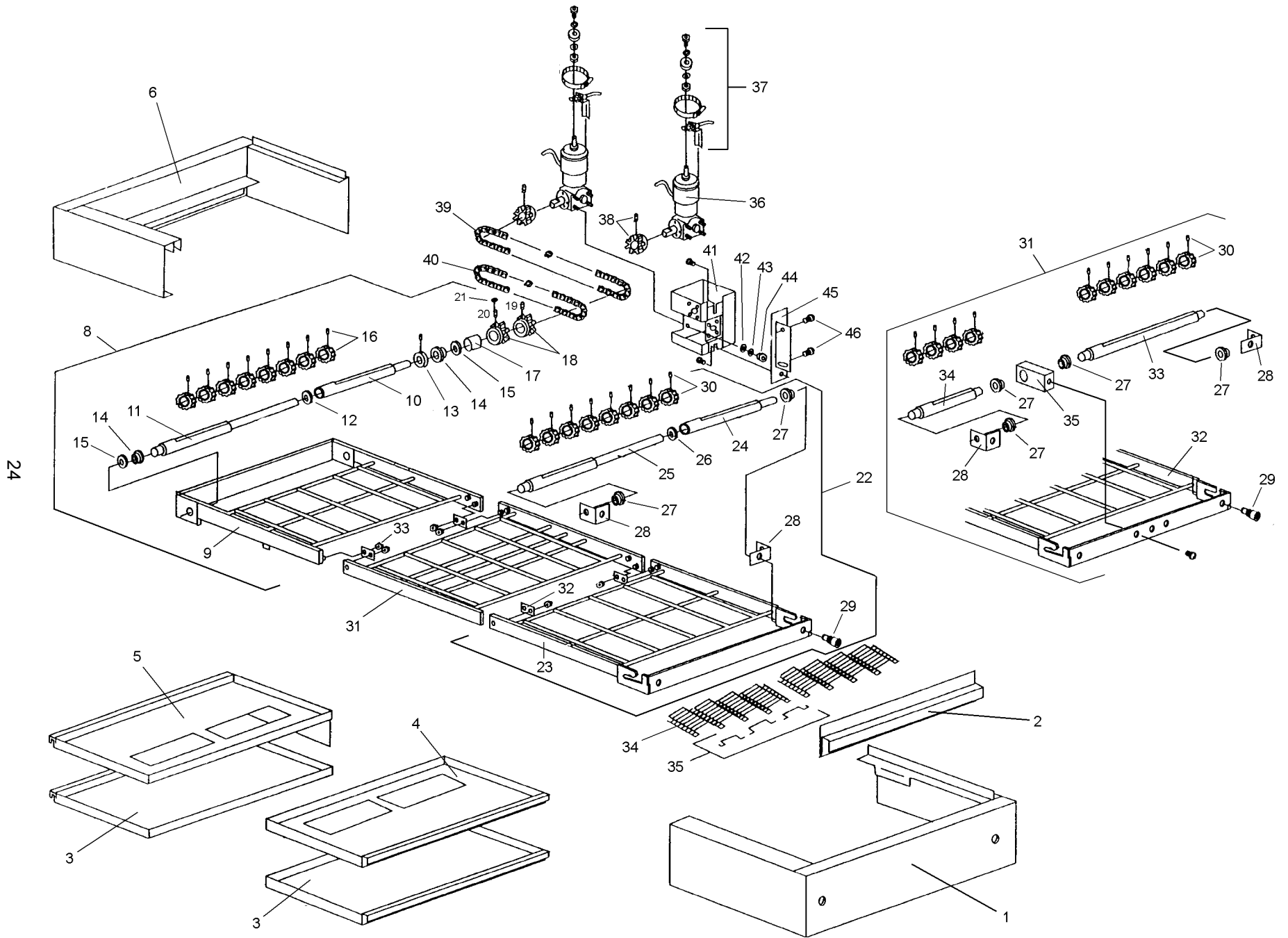

XII. CONVEYOR ASSEMBLY, SPLIT-BELT OVENS

ITEM QTY.	P/N			DESCRIPTION	
	PS360 15"+15" BELTS	PS360WB 19"+19" BELTS	PS360WB 13"+26" BELTS		
1	1	37000-0469	37200-0023	37200-0023	COVER, CONVEYOR EXTENSION, IDLER END
2a	1	35000-1103	35000-1899	35000-1899	CONVEYOR END STOP, STD
2b	1	37000-0524	37000-0524	37000-0524	CONVEYOR END STOP, WIDE - "Q" MODELS ONLY
3	2	35000-0948	35000-1861	35000-1861	CRUMB PAN - ALL SINGLE OVENS, OR LOWER OVEN OF 2-STACK
4	1	35000-1077	35000-1862	35000-1862	CRUMB PAN - UPPER OVEN (IDLER END) OF 2-STACK
5	1	37000-0470	42400-0593	42400-0593	CRUMB PAN WITH HEAT DIVERTER - UPPER OVEN (DRIVE END OF 2-STACK)
6	1	37000-0470	37000-0025	37000-0025	COVER, CONVEYOR EXTENSION, DRIVE END
7	1	42400-0360	--	--	CONVEYOR ASSEMBLY, COMPLETE (WITH BELT)
8	1	42400-0358	--	--	CONVEYOR ASSEMBLY - DRIVE
9	1	37000-0408	37200-0026	37200-0026	CONVEYOR FRAME - DRIVE
10	1	35000-1536	35200-0066	36033	CONVEYOR DRIVE SHAFT - REAR
11	1	42400-0355	42400-0632	36034	CONVEYOR DRIVE SHAFT - FRONT
12	1	21415-0001	21415-0001	21415-0001	FLAT WASHER, BRONZE
13	1	22011-0014	22011-0014	22011-0014	SPLIT LOCKING COLLAR
14	2	22034-0003	22034-0003	22034-0003	BUSHING, 5/8" ID X 3/4" OD X 1/2" LONG
15	2	35000-1080	35000-1080	35000-1080	NYLON SPACER
16a	8	22229-0003	22229-0003	--	CONVEYOR SPROCKET WITH SCREW
16b	10	--	--	22229-0003	CONVEYOR SPROCKET WITH SCREW
--	A/R	21276-0039	21276-0039	21276-0039	SOCKET SET SCREW, 1/4"-28 X 3/8"
17	1	35000-1537	35000-1537	35000-1537	BUSHING SPROCKET, FRONT
18	2	22152-0017	22152-0017	22152-0017	SPROCKET, 9T
19	1	21276-0038	21276-0038	21276-0038	SOCKET SET SCREW, #10-24 X 5/16"
20	1	21276-0049	21276-0049	21276-0049	SOCKET SET SCREW, #10-24 X 1/2"
21	1	A3323	A3323	A3323	HEX NUT, #10-24
22	1	42400-0359	--	--	CONVEYOR ASSEMBLY - IDLER, WITHOUT CENTER SUPPORT BEARING BLOCK
23	1	37000-0409	37200-0027	--	CONVEYOR FRAME - IDLER
24	1	35000-1071	35200-0065	--	CONVEYOR IDLER SHAFT - REAR
25	1	42400-0354	42400-0631	--	CONVEYOR IDLER SHAFT - FRONT
26	1	21415-0001	21415-0001	--	FLAT WASHER, BRONZE
27	2	22034-0003	22034-0003	--	BUSHING, 5/8" ID X 3/4" OD X 1/2" LONG
28	2	37000-0413	37000-0413	--	TENSION ADJUSTMENT BRACKET
29	2	35000-1008	35000-1008	--	TENSION ADJUSTMENT BOLT
30	8	22229-0003	22229-0003	--	CONVEYOR SPROCKET WITH SCREW
--	A/R	21276-0039	21276-0039	--	SOCKET SET SCREW, 1/4"-28 X 3/8"

25

ITEM QTY.	P/N			DESCRIPTION	
	PS360 15"+15" BELTS	PS360WB 19"+19" BELTS	PS360WB 13"+26" BELTS		
31	1	--	--	--	CONVEYOR ASSEMBLY - IDLER, WITH CENTER SUPPORT BEARING BLOCK
32	1	--	36032	36032	CONVEYOR FRAME - IDLER
33	1	--	36961	36037	CONVEYOR IDLER SHAFT - REAR
34	1	--	36961	36040	CONVEYOR IDLER SHAFT - FRONT
35	1	--	33757	33757	IDLER SUPPORT BEARING BLOCK
27	4	--	22034-0003	22034-0003	BUSHING, 5/8" ID X 3/4" OD X 1/2" LONG
28	2	--	37000-0413	37000-0413	TENSION ADJUSTMENT BRACKET
29	2	--	35000-1008	35000-1008	TENSION ADJUSTMENT BOLT
30a	8	--	22229-0003	--	CONVEYOR SPROCKET WITH SCREW
30b	10	--	--	22229-0003	CONVEYOR SPROCKET WITH SCREW
--	A/R	--	21276-0039	21276-0039	SOCKET SET SCREW, 1/4"-28 X 3/8"
31	1	37000-0410	37200-0028	37200-0028	CONVEYOR FRAME - CENTER
32	4	35900-0169	35900-0169	35900-0169	CONVEYOR PIVOT PLATE
33	8	21176-0001	21176-0001	21176-0001	HEX LOCK NUT, 1/4"-20
34a	2	22450-0094	22450-0292	--	CONV. BELT, COMPLETE 174"L
34b	1	--	--	36057	CONV. BELT, COMPLETE 13"W X 174"L
34c	1	--	--	36058	CONV. BELT, COMPLETE 26"W X 174"L
34d	--	33900-0037	39388	--	BELT SECTION, 12"L
34e	--	--	--	36072	BELT SECTION, 13"W X 12"L
34f	--	--	--	36073	BELT SECTION, 26"W X 12"L
35	1	NOT AVAIL.	NOT AVAIL.	NOT AVAIL.	MASTER LINKS KIT
36	2	27384-0008	27384-0008	27384-0008	GEAR MOTOR, 1400:1
--	4	22450-0052	22450-0052	22450-0052	BRUSHES, GEAR MOTOR
37	2	27170-0263	27170-0263	27170-0263	PICKUP ASSEMBLY
38	2	22152-0018	22152-0018	22152-0018	SPROCKET - 15T WITH SET SCREW
39	1	42400-0163	42400-0163	42400-0163	ROLLER CHAIN ASSY - 25-1/2", WITH MASTER LINK
40	1	42400-0160	42400-0160	42400-0160	ROLLER CHAIN ASSY - 14-1/2", WITH MASTER LINK
41	1	37000-0632	37000-0632	37000-0632	MOTOR MOUNTING BRACKET
42	8	21411-0003	21411-0003	21411-0003	FLAT WASHER, 1/4"
43	8	21426-0002	21426-0002	21426-0002	LOCKWASHER, 1/4"
44	8	21126-0009	21126-0009	21126-0009	HEX NUT, 1/4"-20
45	1	37000-0427	37000-0427	37000-0427	MOTOR MOUNTING WELDMENT
46	4	21212-0002	21212-0002	21212-0002	SCREW, CAP HEX HD 1/4"-20 X 3/4"

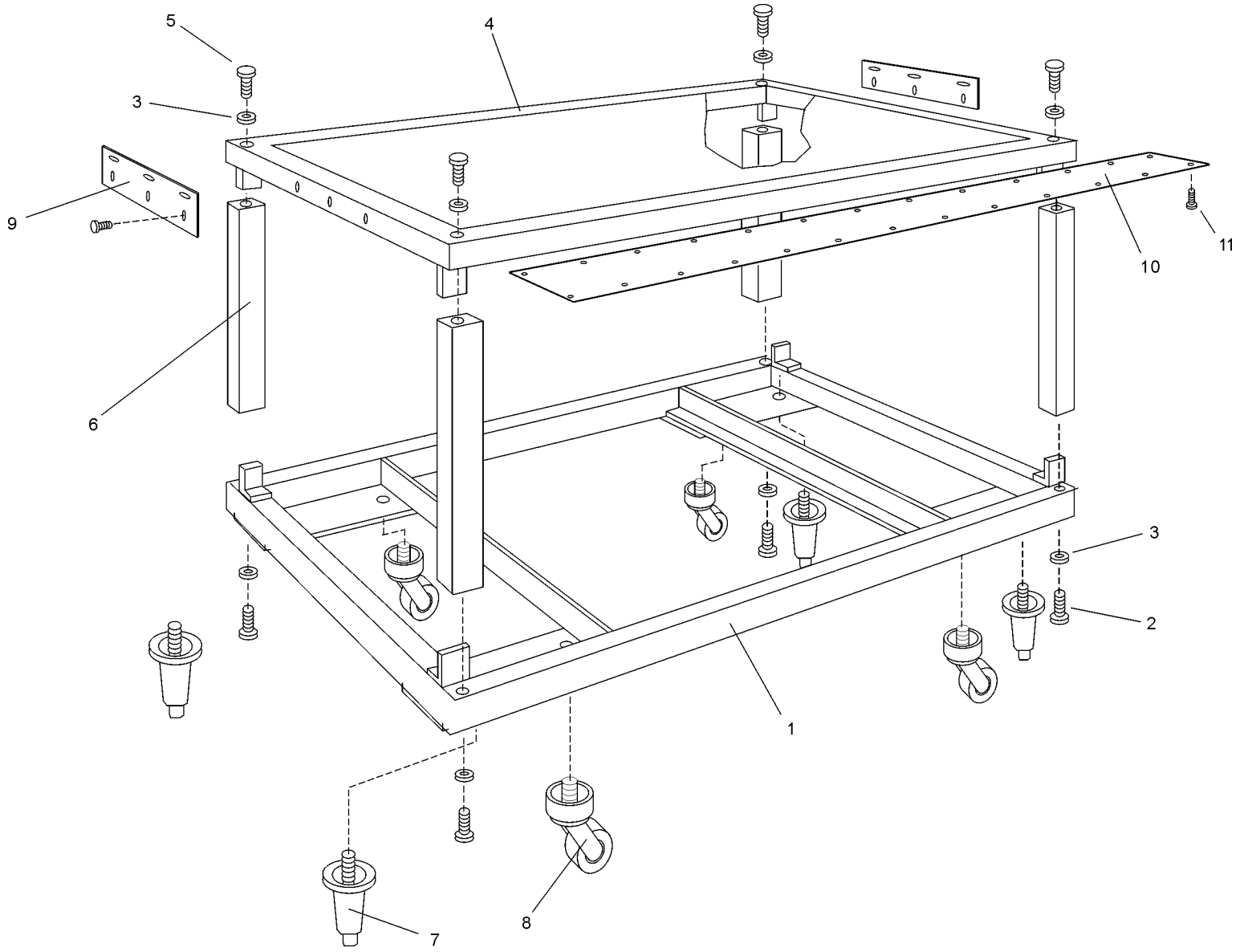
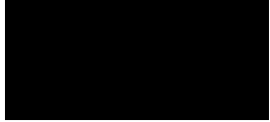

XIII. UPPER OVEN STAND

<i>ITEM</i>	<i>QTY.</i>	<i>PS310/314/360</i>	<i>PS360WB</i>	<i>DESCRIPTION</i>
--	1(49009-0005(32433(UPPER OVEN STAND ASSEMBLY(
1(1(37115-0208(31890(BOTTOM FRAME WELDMENT(
2(4(21211-0034(21211-0034(HEX HEAD BOLT, 1/2"-13 X 3"(
3(8(21421-0002(21421-0002(LOCKWASHER(
4(1(37115-0207(31899(TOP FRAME WELDMENT(
5(4(21251-0019(21251-0019(HEX SOCKET HEAD SCREW 1/2"-13 X 1"(
6	4(37115-0209(37115-0209(CORNER POST WELDMENT(
7(4(22450-0028(22450-0028(6" LEG WITH ADJUSTABLE 3/4" STUD(
8(4(37115-0102(37115-0102(CASTER (INCLUDED WITH INSTALLATION KIT)(
9(2(35122-0049(35122-0049(TIE PLATE ATTACHMENT STRIP (INCLUDED WITH INSTALLATION KIT)(
10(1(35000-1236*(--	COVER PLATE, INSULATION(
11(A/R(21292-0001(--	SCREW, HEX WSHR HD #10-16 X 3/4"(

* NOTE: The insulation cover plate is only used for PS360, -360S, and -360Q ovens.(

WARNING

Improper installation, adjustment, alteration, service or maintenance can cause property damage, injury or death. Read the installation, operating and maintenance instructions thoroughly before installing or servicing this equipment.

NOTICE

During the warranty period, ALL parts replacement and servicing should be performed by your Middleby Marshall Authorized Service Agent. Service that is performed by parties other than your Middleby Marshall Authorized Service Agent may void your warranty.

NOTICE

Using any parts other than genuine Middleby Marshall factory manufactured parts relieves the manufacturer of all warranty and liability.

NOTICE

Middleby Marshall reserves the right to change specifications at any time.

Middleby Cooking Systems Group • 1400 Toastmaster Drive • Elgin, IL 60120 • USA • (847)741-3300 • FAX (847)741-4406

24-Hour Service Hotline: 1-(800)-238-8444

www.middleby.com

