

PS314SBI Gas and Electric Ovens

Models:

- PS314SBI

PARTS MANUAL

for domestic and standard export ovens

© 2000 Middleby Marshall, Inc.



**Middleby
Marshall®** is a registered trademark of Middleby Marshall, Inc. All rights reserved.

Middleby Cooking Systems Group • 1400 Toastmaster Drive • Elgin, IL 60120 • (847)741-3300 • FAX (847)741-4406

TABLE OF CONTENTS

<i>Section</i>	<i>Page</i>
I. Key Spare Parts Kit	3
II. Installation Kit	4
III. Oven Panels and Legs	6
IV. Shrouds and Vents	8
V. Machinery Compartment and Burner Chamber	10
VI. Electrical Components	12
VII. Electric Panel (<i>Electrically Heated Ovens Only</i>)	14
VIII. Control Panel and Door Assemblies	16
IX. Electric Heaters (<i>Electrically Heated Ovens Only</i>)	18
X. Gas Burner System (<i>Gas-Fired Ovens Only</i>)	20
XI. Conveyor Assembly	22

NOTE: Throughout this Parts Manual, the following abbreviations are used:

A/R = Quantity As Required

N/A = Does Not Apply

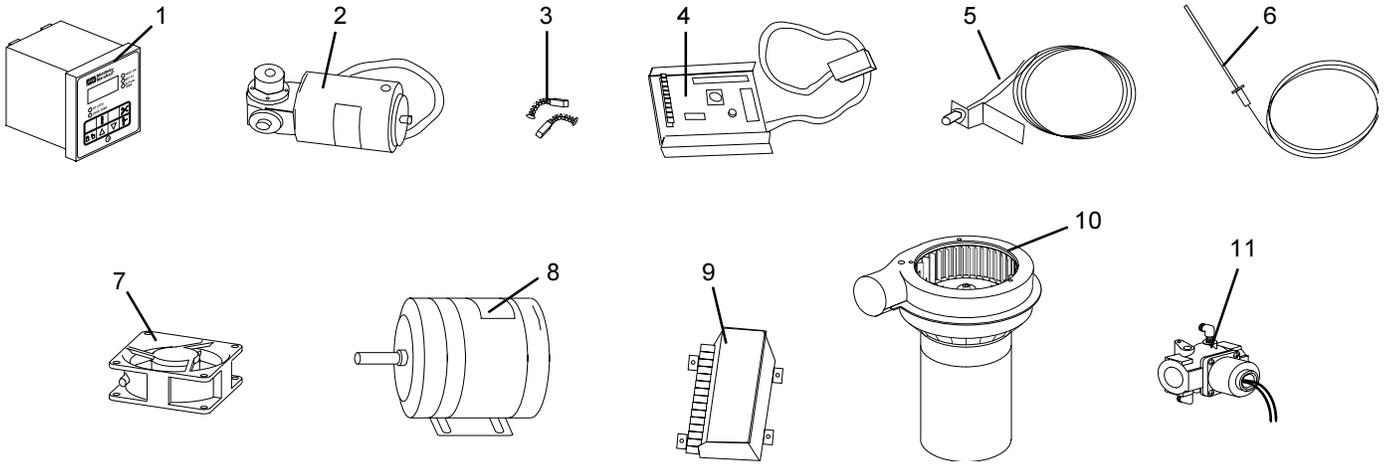

I. KEY SPARE PARTS KIT

ITEM	DESCRIPTION	PART NO.
1 1	KIT, DIGITAL TEMPERATURE CONTROLLER	36939
2 1	CONVEYOR DRIVE MOTOR	27384-0003
3 2	BRUSHES, CONVEYOR DRIVE MOTOR	22450-0052
4 1	KIT, CONVEYOR SPEED CONTROLLER	42810-0133
5 1	CONVEYOR CONTROL PICKUP ASSEMBLY	27170-0263
6 1	KIT, THERMOCOUPLE	33984
7 1	COOLING FAN	27392-0002
8A 1	BLWR MTR, 1 PH, 1/3 HP	27381-0023
8B 1	BLOWER MOTOR, 3 PH, 1/3 HP	27381-0024

ADDITIONAL KEY SPARE PARTS KIT COMPONENTS FOR GAS OVENS

9 1	KIT, IGNITION MODULE	42810-0114
10 1	BURNER BLOWER/MOTOR ASSEMBLY	27170-0011
11 1	SOLENOID VALVE	28091-0017

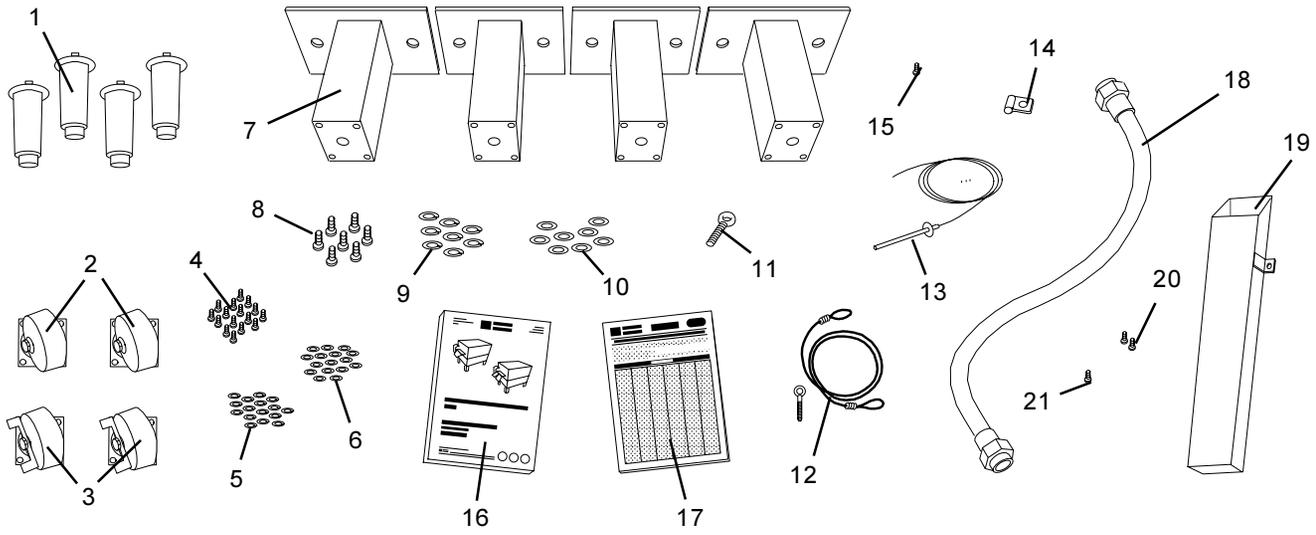

II. INSTALLATION KIT

<i>ITEM</i>	<i>DESCRIPTION</i>	<i>PART NO.</i>	<i>QTY.</i>
1	LEGS, ADJUSTABLE	22450-0028	4
2	CASTER (REAR), SWIVEL	22290-0010	2
3	CASTER (FRONT), SWIVEL, WITH BRAKE	22290-0009	2
4	SCREW, HEX, 3/8-16 X 1"	220373	16
5	LOCKWASHER, 3/8"	21422-0001	16
6	FLAT WASHER, 3/8"	21416-0001	16
7	LEG, 9" (229MM)	34684	4
8	SCREW, HEX, 3/4-10 X 2"	21321-0016	7
9	LOCKWASHER, 3/4"	21421-0003	8
10	FLAT WASHER, 3/4"	21411-0019	8
11	SHOULDER EYEBOLT, 3/4"-10 X 2"	42440	1
12	RESTRAINT CABLE ASSEMBLY	22450-0228	1
13	THERMOCOUPLE	33812-1	1
14	CABLE CLAMP	27276-0001	1
15	SCREW, #10-32 X 3/8"	21256-0008	1
16	MODEL PS314SBI OWNER'S OPERATING AND INSTALLATION MANUAL	42447	1
17	AUTHORIZED SERVICE AGENCY LISTING	1002040	1

ADDITIONAL INSTALLATION KIT COMPONENTS FOR GAS OVENS

18	GASHOSE, FLEXIBLE	22361-0001	1
19	FLUE VENT, 14" (356MM)	30773	1
20	SCREW, HEX, #2PT 10-16 X 3/4" HWH	21292-0001	2
21	SCREW, #10-32 X 3/8"	21256-0008	1

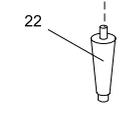
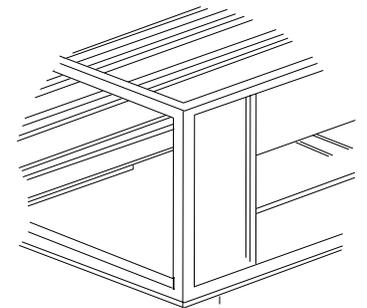
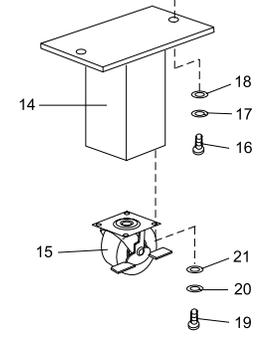
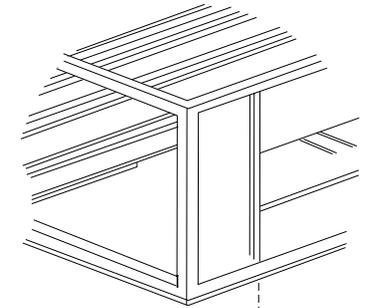
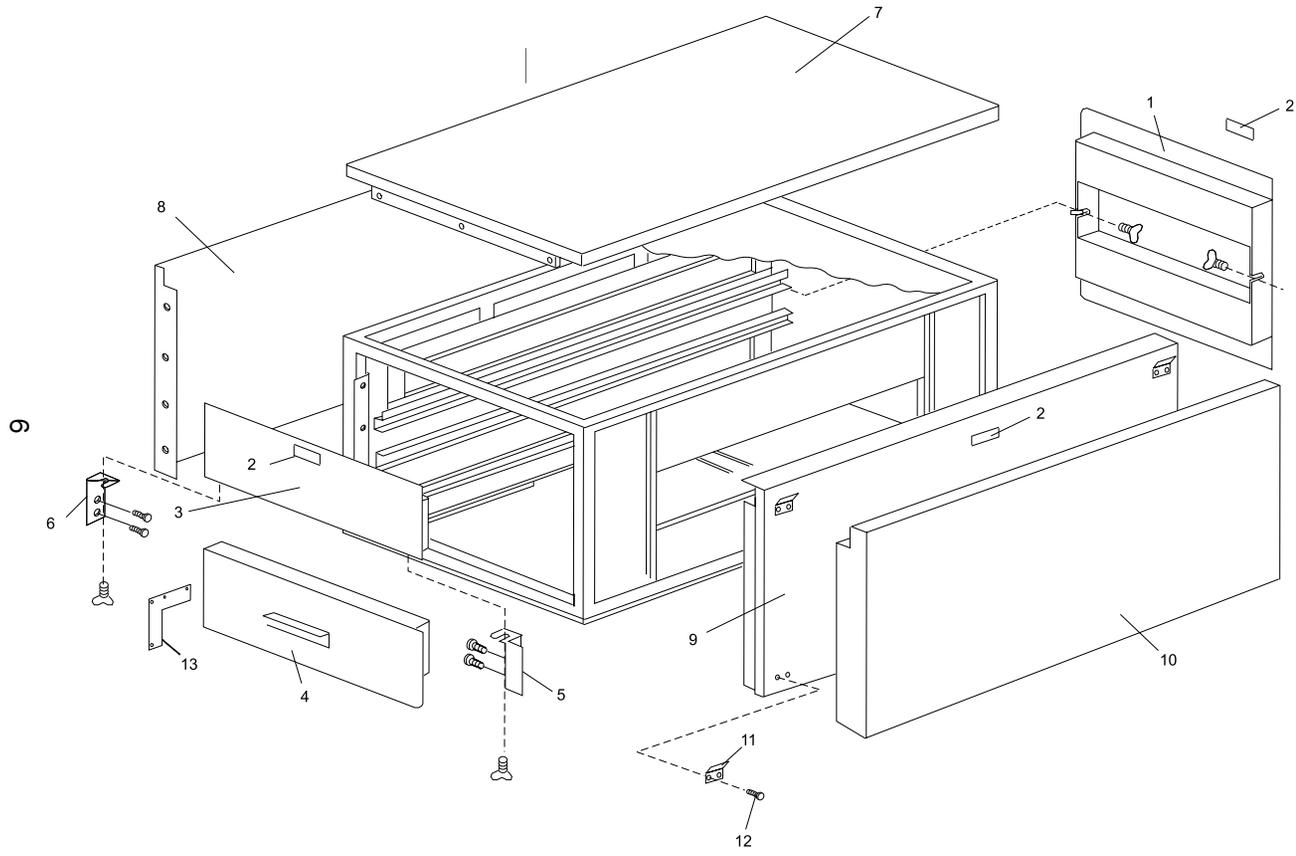

III. OVEN PANELS AND LEGS

<i>ITEM</i>	<i>QTY.</i>	<i>PART NO.</i>	<i>DESCRIPTION</i>
1	1	37000-0675	ENDPLUG, RIGHT
2	3	22500-0041	LABEL, "CAUTION - HOT SURFACE"
3	1	37000-0466	ENDPLUG, UPPERLEFT
4	1	37000-0677	ENDPLUG, LOWERLEFT
5	1	33230	ENDPLUGBRACKET, FRONTLEFT
6	1	33229	ENDPLUGBRACKET, REARLEFT
7	1	35000-1494	PANEL, TOP
8	1	37000-0451	PANEL, REAR
9	1	34354	PANEL, FRONT
--	A/R	22131-0004	INSULATION (INSIDE TOP, REAR, AND FRONT PANELS), 1" (25mm) THICK
10	1	35471	COOL FRONT PANEL
11	4	35000-1622	HANGER, COOL FRONT PANEL
12	16	21292-0001	SCREW, 10-16 x 3/4", HEX WASHER HD
13	1	35049	BRACE, CONVEYOR MOTOR SUPPORT
14	4	34684	LEG, 9" (229mm)
15	2	22290-0009	CASTER (FRONT), SWIVEL WITH BRAKE
15	2	22290-0010	CASTER (REAR), SWIVEL
16	8	21321-0016	SCREW, HEX 3/4-10 x 2"
17	8	21421-0003	WASHER, LOCK 3/4"
18	8	21411-0019	WASHER, FLAT 3/4"
19	16	220373	SCREW, HEX 3/8-16 x 1"
20	16	21422-0001	WASHER, LOCK 3/8"
21	16	21416-0001	WASHER, FLAT 3/8"
22	4	22450-0028	LEG, 6" (152mm), ADJUSTABLE

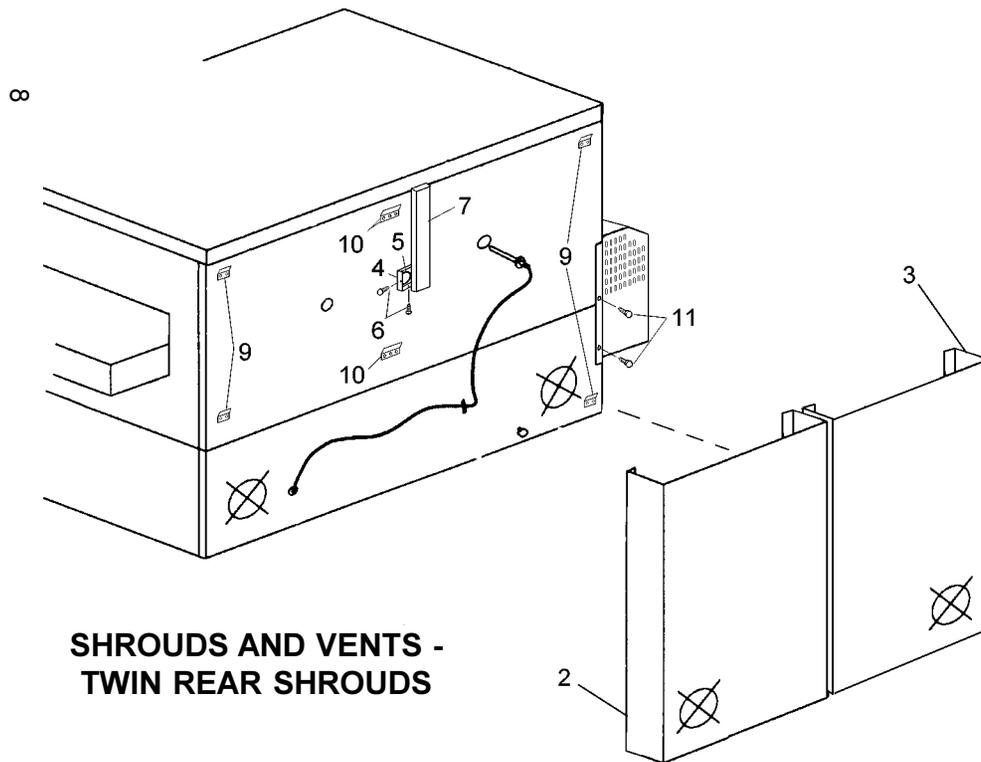

**SHROUDS AND VENTS -
TWIN REAR SHROUDS**

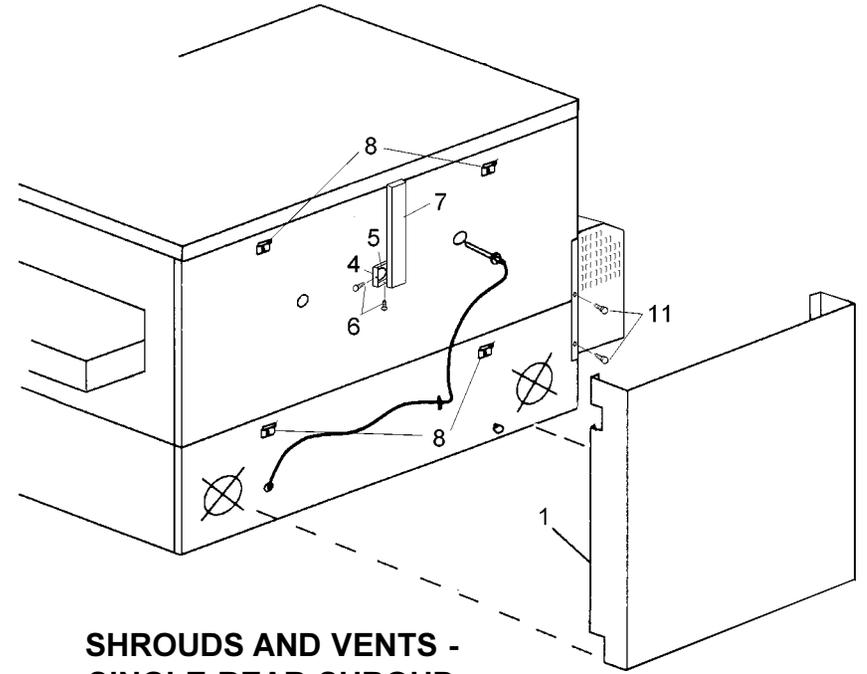

**SHROUDS AND VENTS -
SINGLE REAR SHROUD**

IV. SHROUDS AND VENTS

<i>ITEM</i>	<i>QTY.</i>	<i>PART NO.</i>	<i>DESCRIPTION</i>
1	1	35000-1626	SHROUD ASSEMBLY, REAR - OVENS WITH SINGLE REAR SHROUD ONLY
2	1	35253	SHROUD ASSEMBLY, REAR LEFT - OVENS WITH TWIN REAR SHROUDS ONLY
3	1	35254	SHROUD ASSEMBLY, REAR RIGHT - OVENS WITH TWIN REAR SHROUDS ONLY
4	1	30758	VENT MOUNTING BOX
5	1	27280-0005	NUT, VENT PIPE
6	8	21256-0008	SCREW, HEX WSHR HD, 10-32 X 3/8"
7	1	30773	VENT PIPE, 13" (330mm)
8	2	33223	HANGER, SINGLE REAR SHROUD
9	4	35000-1622	HANGER, TWIN REAR SHROUDS, 1-1/2" (38mm)
10	2	35256	HANGER, TWIN REAR SHROUDS, 3" (76mm)
11	2	21296-0003	WING SCREW, 1/4-20 x 1/2"
--	1	28082-0010	TRANSFORMER, 750VA, 280/480PV/120/240SV - 480V ELECTRIC OVENS ONLY

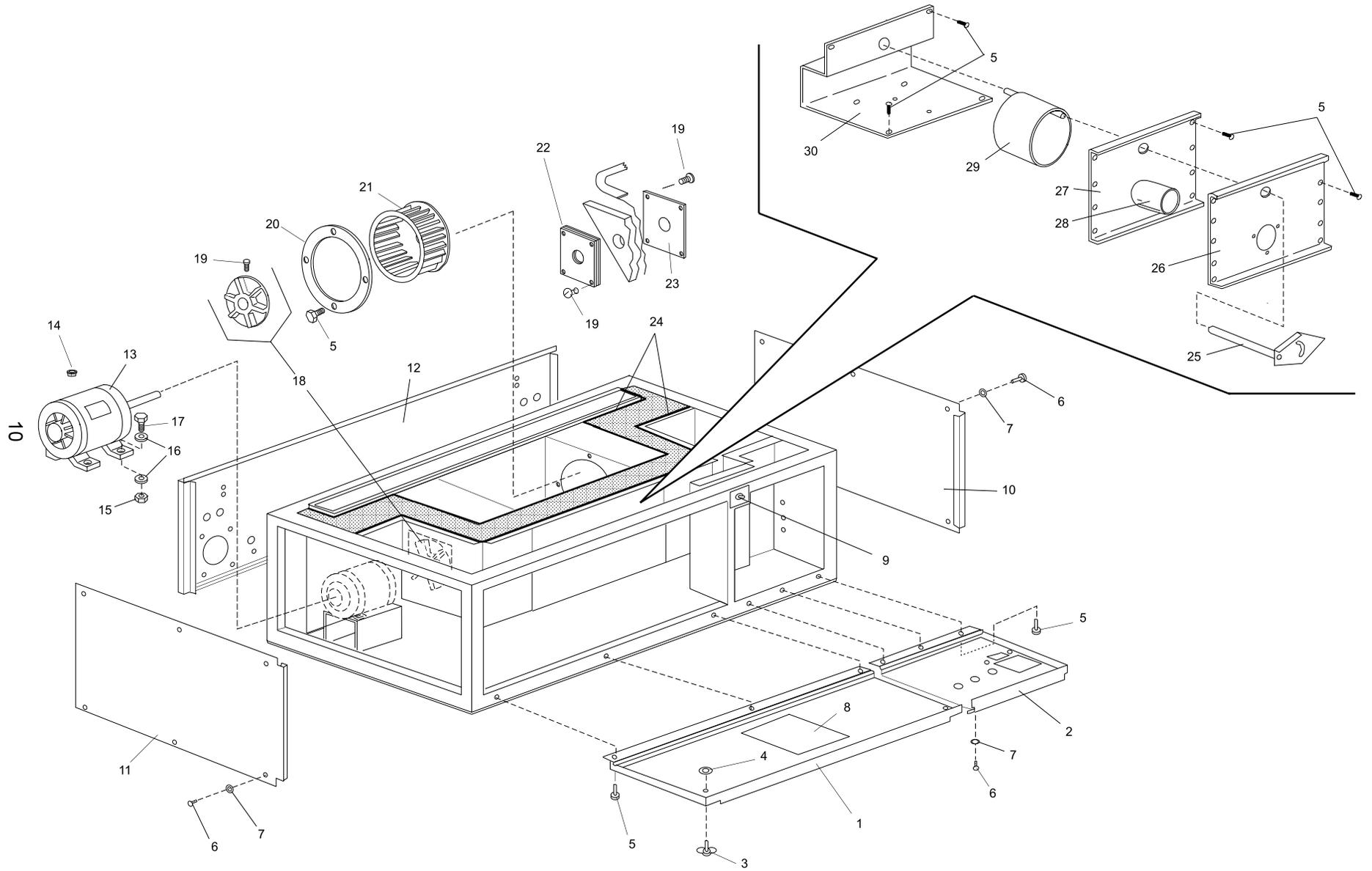

V. MACHINERY COMPARTMENT AND BURNER CHAMBER

ITEM	QTY.	PART NO.	DESCRIPTION
1	1	37000-0450	FRONT DOOR PANEL - MACHINERY COMPARTMENT
2	1	37000-0656	FRONT DOOR PANEL - CONTROL COMPARTMENT
3	2	21272-0014	SCREW, MACHINE 10-24 x 1-1/4"
4	2	21886-0010	RETAINER, SCREW
5	A/R	21292-0001	SCREW, HEX WASHER HD 10-16 x 3/4"
6	A/R	31451	SCREW, TRUSS HD, 10-24 x 1/2"
7	A/R	21475-0001	FINISHING WASHER, #10
8	1	22500-0062	LABEL, MAINTENANCE SCHEDULE
9	1	28021-0047	SWITCH, DOOR SAFETY
10	1	35000-0958	END PANEL, RIGHT
11	1	35000-0959	END PANEL, LEFT
12	1	35000-0957	REAR PANEL
13	2	27381-0023	MOTOR, 1/3HP, 110/220V, 50/60Hz, 1 Ph
14	2	27221-0015	BUSHING, WIRING, SNAP-IN
15	8	B10012	NUT, HEX 5/16-18
16	16	21412-0005	FLAT WASHER, 5/16"
17	8	A3896	SCREW, HEX HD, 5/16-18 x 1"
18	2	27396-0004	ASSEMBLY, HEAT SLINGER
19	2	21276-0035	SET SCREW, 1/4-20 - INC. WITH ITEM 18
20	2	22450-0062	INLET CONE, 9-3/16"
21	1	22523-0002	BLOWER WHEEL, CLOCKWISE (LEFT SIDE)
21	1	22523-0003	BLOWER WHEEL, COUNTER-CLOCKWISE (RIGHT SIDE)
22	2	37115-0151	SEAL, INNER, MOTOR SHAFT
23	2	35131-0038	PLATE, HEAT SINK
24	1	22420-0005	GASKET, 153" (144" REQUIRED)
25	1	37000-0658	PLATE, FLAME TUBE ADJUSTMENT
26	1	37000-0236	OUTER BURNER MOUNTING PLATE
27	1	35000-1036	INNER BURNER MOUNTING PLATE
28	1	35112-0075	BURNER TUBE
29	1	37000-0659	FLAME TUBE, ADJUSTABLE
30	1	35333-0003	BURNER SHIELD

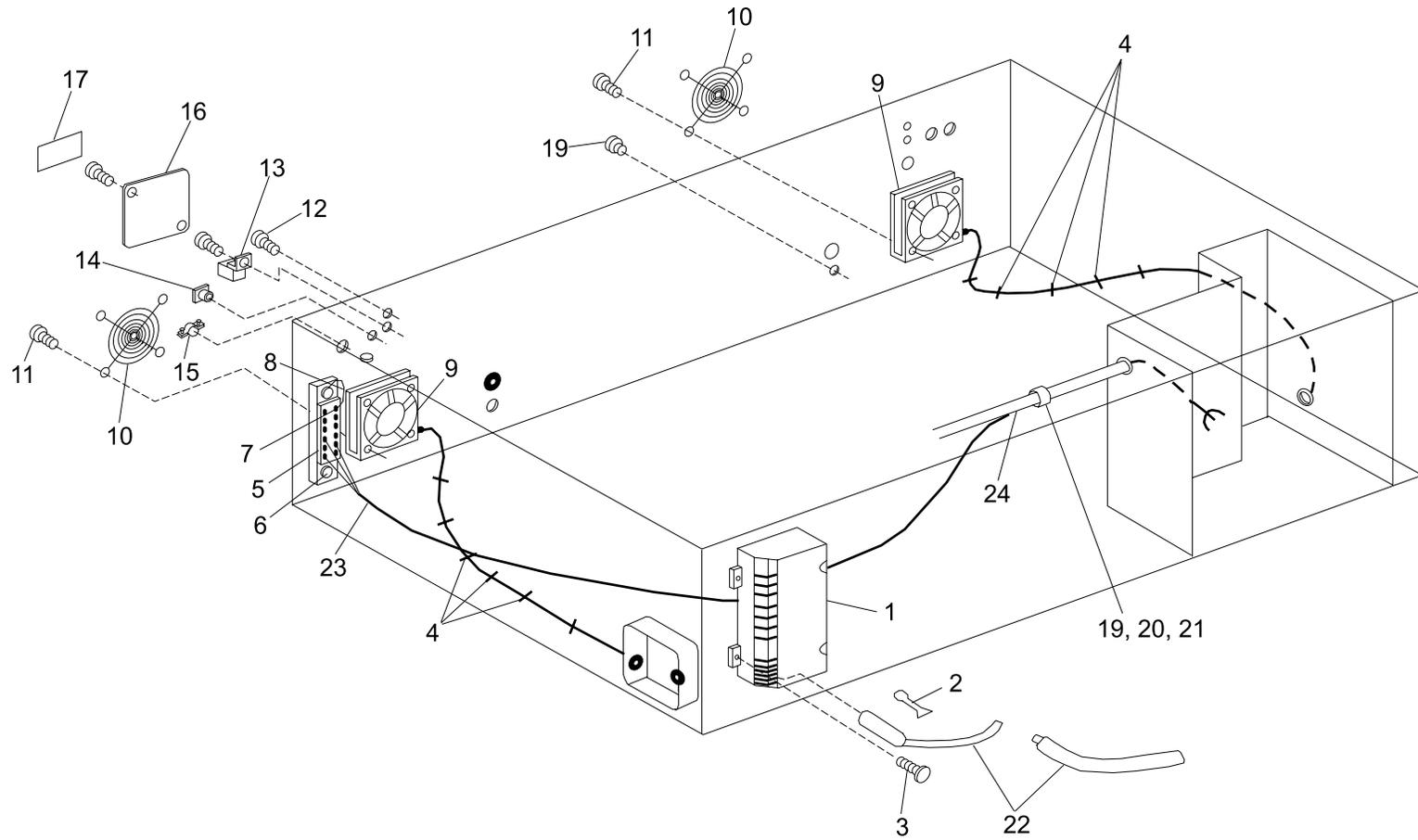

VI. ELECTRICAL COMPONENTS

<i>ITEM</i>	<i>QTY.</i>	<i>PART NO.</i>	<i>DESCRIPTION</i>
1	1	42810-0114	IGNITIONMODULEKIT(WITHADAPTER)
2	1	27161-0006	ADAPTER, IGNITION MODULE - <i>INC. WITH ITEM 1</i>
3	3	21278-0007	SCREW, 8-32 x 1-1/8", SLT RND HD
4	A/R	27311-0002	CABLE TIE, PLASTIC
5	1	27011-0013	TERMINAL BLOCK, CONVEYOR MOTOR
6	2	21278-0002	SCREW, 8-32 x 3/4", SLT RND HD
7	A/R	27255-0008	DISCONNECT
8	1	42400-0256	ASSEMBLY, GROUND WIRE
9	2	27392-0002	FAN, COOLING
--	2	27159-0003	CORDSET, COOLING FAN
10	2	27470-0004	GRILLE, COOLING FAN
11	8	21226-0007	SCREW, 10-24 x 1/2", SLT PAN HD
12	A/R	21292-0001	SCREW, 10-16 x 3/4", HEX WASHER HD
13	A/R	15028707	TERMINAL, SOLDERLESS LUG, #6-14 AWG
14	1	27321-0009	STRAINRELIEF
15	1	27082-0008	CABLE CONNECTOR, STRAIGHT, CLAMP TYPE
16	1	27304-0001	COVER, JUNCTION BOX
17	1	22500-0042	LABEL, "CAUTION HIGH LEG"
18	5	23035-0001	PLUG, PLASTIC, 1/8"
19	2	21221-0015	SCREW, 1/4-20 x 3/4", SLT RND HD
20	2	B301A8817	NUT, 1/4-20 HEX
21	4	27276-0002	CLAMP, NYLON CABLE
22	1	27159-0013	IGNITION CABLE, 30"
23	1	42400-0334	SHIELDED PICKUP, CONVEYOR CABLE
24	1	42400-0459	WIRING HARNESS

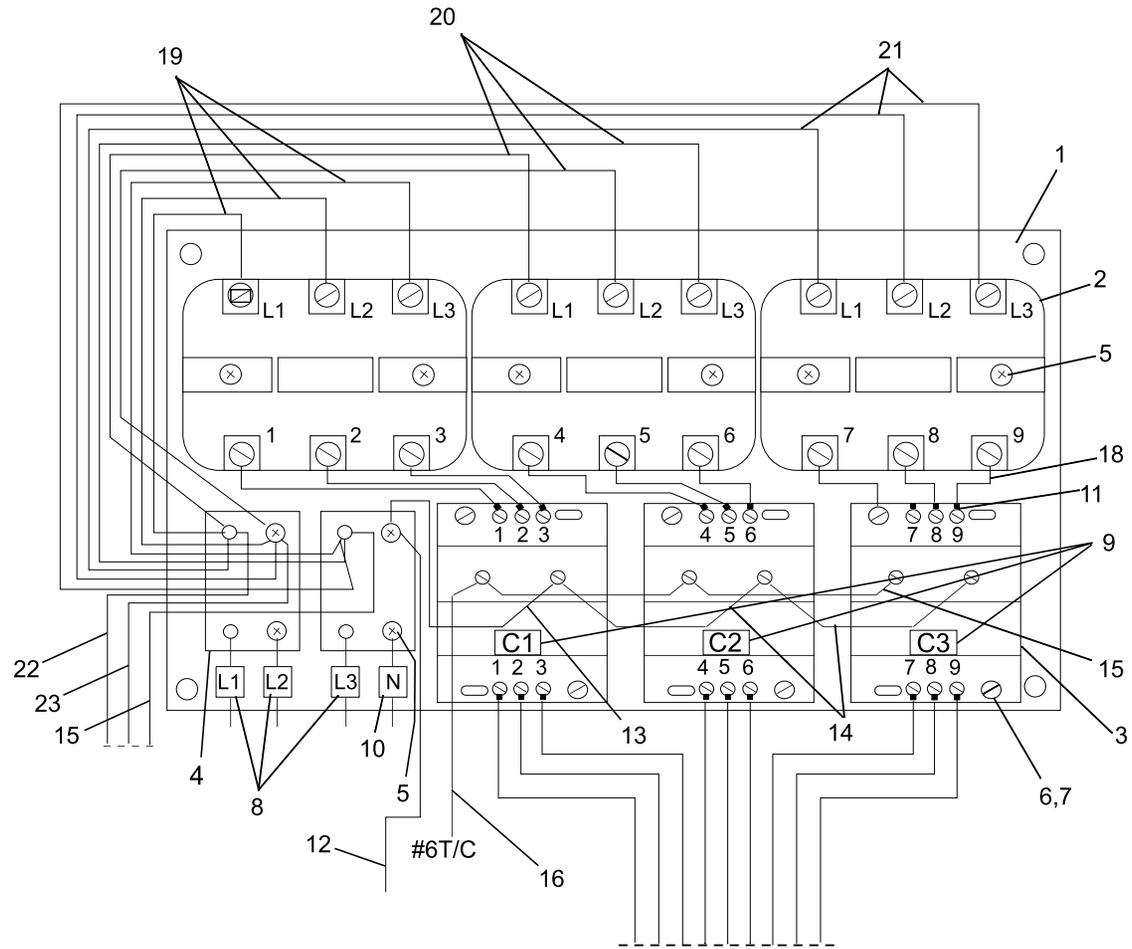

VII. ELECTRIC PANEL

<i>ITEM</i>	<i>QTY.</i>	<i>PART NO.</i>	<i>DESCRIPTION</i>
--	1	42400-0200	ASSEMBLY, ELECTRIC PANEL AND ALL COMPONENTS
1	1	35000-0295	ELECTRIC PANEL WITHOUT COMPONENTS
2	3	27021-0016	FUSE BLOCK - 3P, 60A/600V, CLASS "T"
3	3	28041-0016	MERCURY CONTACTOR - 3P, 30A, 120V, 50/60HZ
4	2	27480-0001	POWER DISTRIBUTION BLOCK - 2 POLE
5	10	21281-0004	SCREW, #8 X 5/8" AB PH PAN HD. S/ZN
6	6	21278-0002	SCREW, 8-32 X 3/4", RND HD S1 ZN
7	6	21412-0010	WASHER, FLAT NI #8
8	3	27352-0003	MARKER, WIRE L1, L2, L3
9	3	27352-0005	MARKER, WIRE C1, C2, C3
10	1	27352-0002	MARKER WIRE LETTERS
11	9	27252-0023	TERMINAL LOCKING SPADE
12	8 ft. (2.44m)	27152-0053	WIRE STRAND, 18 GA AWM 105C WHITE
13	1 ft. (0.30m)	27152-0053	WIRE STRAND, 18 GA AWM 105C WHITE
14	1 ft. (0.30m)	27152-0053	WIRE STRAND, 18 GA AWM 105C WHITE
15	8 ft. (2.44m)	27152-0002	WIRE STRAND, 16 GA AWM 105C BLUE
16	1 ft. (0.30m)	27152-0049	WIRE STRAND, 18 GA AWM 105C BLUE
17	2 ft. (0.61m)	27152-0049	WIRE STRAND, 18 GA AWM 105C BLUE
18	3 ft. (0.91m)	27152-0025	WIRE STRAND, 10 GA AWM 105C BLACK
19	3 ft. (0.91m)	27152-0025	WIRE STRAND, 10 GA AWM 105C BLACK
20	3 ft. (0.91m)	27152-0025	WIRE STRAND, 10 GA AWM 105C BLACK
21	4 ft. (1.22m)	27152-0025	WIRE STRAND, 10 GA AWM 105C BLACK
22	8 ft. (2.44m)	27152-0001	WIRE STRAND, 16 GA AWM 105C BLACK
23	8 ft. (2.44m)	27152-0007	WIRE STRAND, 16 GA AWM 105C RED
--	9	28150-0134	FUSE - 600V, 40A, CLASS "T"
--	1	22500-0040	LABEL "WARNING FUSE RATING AMPS"
--	1	28071-0014	HIGH LIMIT SWITCH

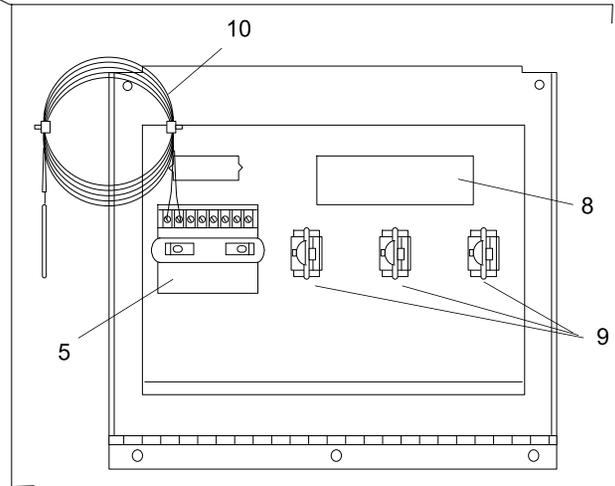
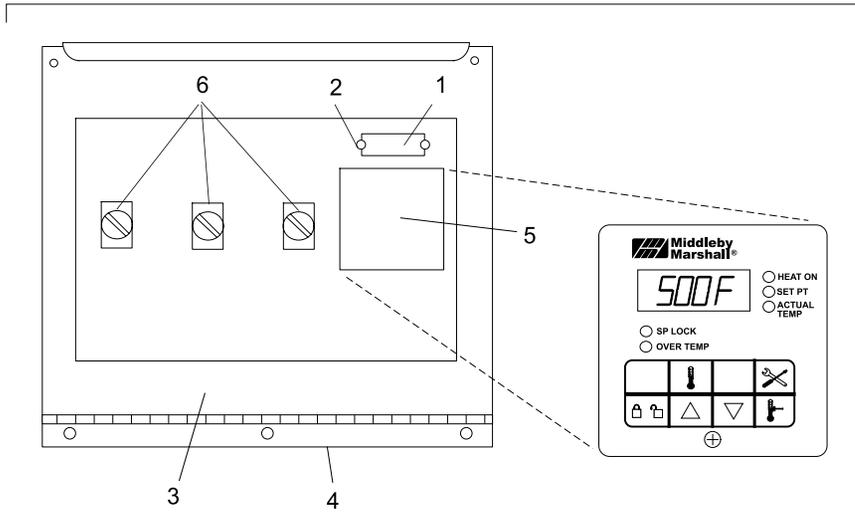
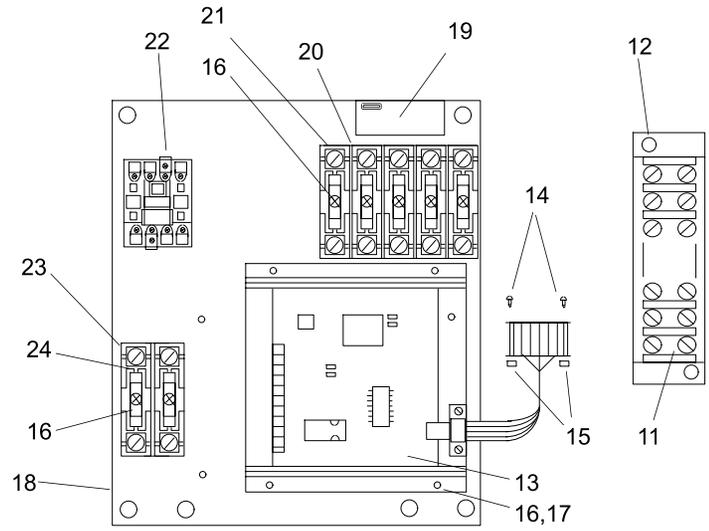
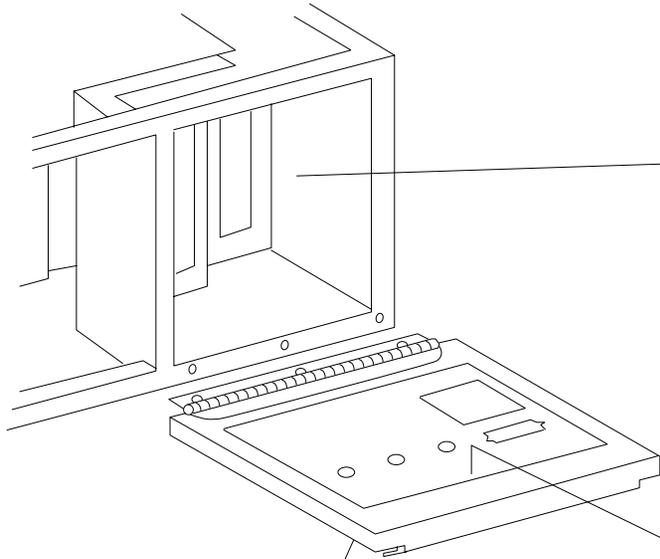

VIII. CONTROL PANEL AND DOOR ASSEMBLIES

ITEM	QTY.	PART NO.	DESCRIPTION
1	1	42810-0118	THUMBWHEEL SWITCH -INC. WITH ITEM 13
2	2	21278-0003	SCREW, 4-40 x 1/4", SLT RND HD
3	1	42400-0277	CONTROL DOOR ASSEMBLY, WIRED
4	1	37000-0656	PANEL, CONTROL DOOR (WITHOUT COMPONENTS)
5	1	36939	KIT, TEMPERATURE CONTROLLER
6	3	28021-0062	SELECTOR SWITCH, 2-POSITION, BLUE
8	1	22500-0061	LABEL, WIRING DIAGRAM
9	3	27060-0012	CONTACT BLOCK WITH BASE
10	1	33984	KIT, THERMOCOUPLE
11	1	27011-0011	TERMINAL BLOCK, 8-POLE, 30A, 600V
12	2	21281-0004	SCREW, #8 x 5/8, PHILLIPS PAN HD
13	1	42810-0133	KIT, CONVEYOR SPEED CONTROLLER
14	2	21278-0003	SCREW, 4-40 x 1/4", SLTD RND HD
15	2	21126-0010	HEX NUT, 4-40, SS
16	7	21281-0005	SCREW, 8-32 x 1/2", PAN HD
17	1	21442-0001	LOCKWASHER, #8, EXTERNAL-TOOTH
18	1	42400-0273S	CONTROL PANEL ASSEMBLY - GAS OVENS, WIRED - <i>INCLUDES ITEMS 19-22</i>
18	1	34710	CONTROL PANEL ASSEMBLY - 208V/240V ELECTRIC OVENS, WIRED - <i>INCLUDES ITEMS 19-22</i>
18	1	42400-0300	CONTROL PANEL ASSEMBLY - 440V ELECTRIC OVENS, WIRED - <i>INCLUDES ITEMS 19-24</i>
--	1	35232-0010	CONTROL PANEL (NO COMPONENTS INCLUDED)
19	1	22500-0040	LABEL - WARNING, FUSE AMPS
20	1	27021-0011	FUSE BLOCK
21	7	28154-0003	FUSE, MIDGET, TIME DELAY, 9A, 250V
22	1	28041-0008	CONTACTOR, 4-POLE
23	1	27021-0012	FUSE BLOCK - <i>FOR 440V ELECTRIC OVENS ONLY</i>
24	2	28154-0009	FUSE, MIDGET, 5A, 600V - <i>FOR 440V ELECTRIC OVENS ONLY</i>

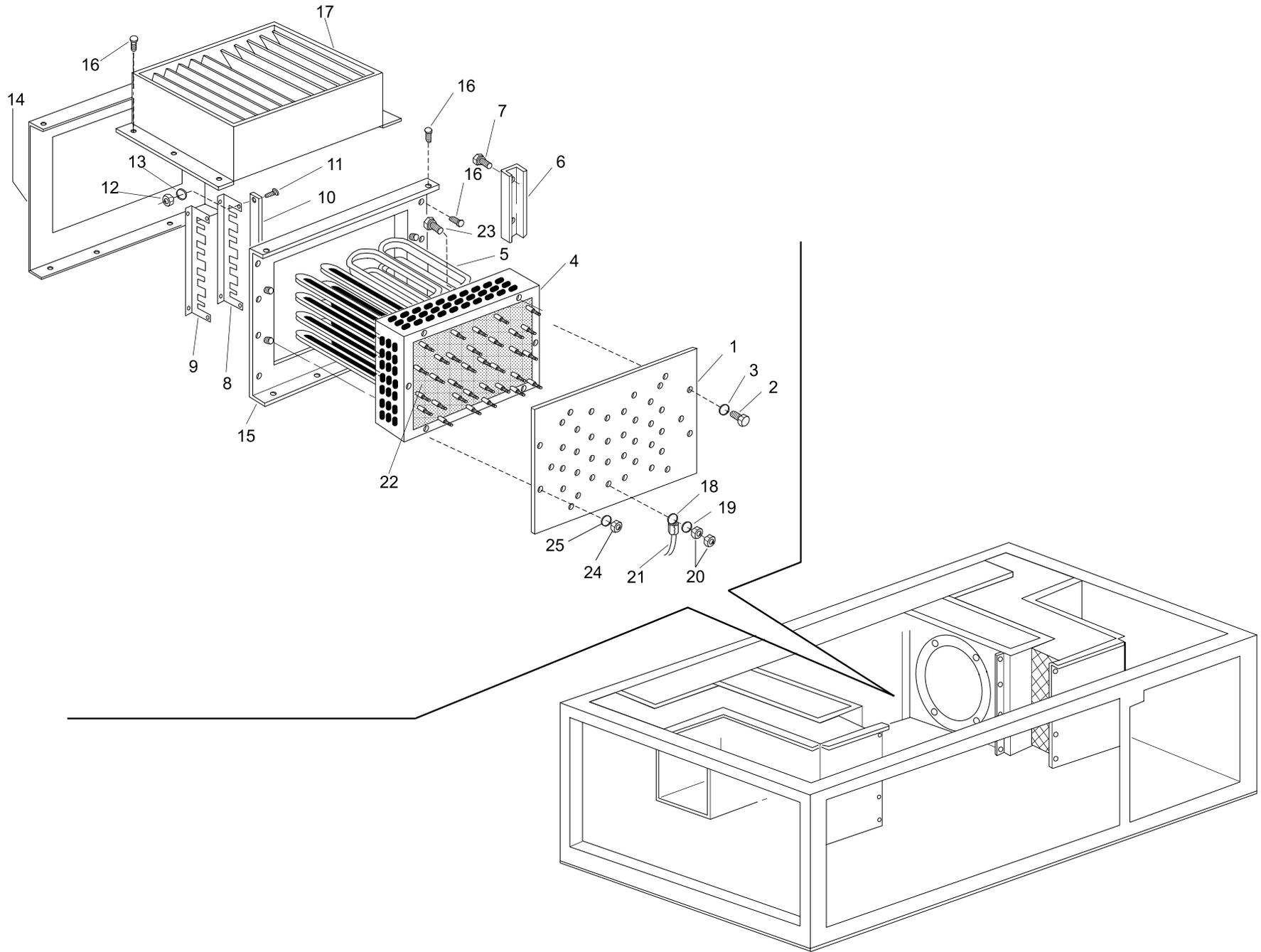

IX. ELECTRIC HEATERS

<i>ITEM</i>	<i>QTY.</i>	<i>PART NO.</i>	<i>DESCRIPTION</i>
--	1	42400-0310	HEATING ELEMENT ASSEMBLY, 208V
--	1	42400-0311	HEATING ELEMENT ASSEMBLY, 240V
--	1	42400-0314	HEATING ELEMENT ASSEMBLY, 480V
1	1	35000-1316	HEATING ELEMENT COVER
2	6	A6153	SCREW, 1/4-20 x 1/2", HEX HD
3	6	21426-0002	LOCKWASHER, 1/4" SS
4	1	37000-0562	MOUNTING PLATE, HEATER
5	18	27374-0001	HEATING ELEMENT, 208V
5	18	27374-0002	HEATING ELEMENT, 240V/480V
6	4	35000-1340	BRACKET HOLDER, HEATING ELEMENT
7	8	A3896	SCREW, 5/16-18 x 1", HEX HD, SS
8	2	35000-1337	HEATING ELEMENT SPACER (4)
9	2	35000-1338	HEATING ELEMENT SPACER (5)
10	4	35000-1339	HEATING ELEMENT SPACER BAR
11	8	21226-0007	SCREW, 10-24 x 1/2", MS RND HD, SS
12	8	A3323	HEX NUT, 10-24 SS
13	8	21426-0005	LOCKWASHER, #10 SS
14	1	35000-1199	INNER PLATE
15	1	35000-1200	OUTER PLATE
16	36	21292-0001	SCREW, 10-16 x 3/4" HEX HD
17	1	37116-0022	BAFFLE
18	A/R	27252-0005	TERMINAL, RING, 12 AWG 1200°F (649°C)
19	A/R	21426-0005	LOCKWASHER, #10 SS
20	A/R	21126-0007	HEX NUT, 10-32 SS
21	A/R	27152-0047	WIRE, STRAND 12 AWG (842°F/450°C TEMP. RATING)
22	A/R	22134-0002	INSULATION - CERAWOOL, 2" THICK x 24" WIDE
23	8	A3896	SCREW, 5/16-18 X 1" HEX HD SS
24	4	21126-0004	HEX NUT, 5/16"-18 SS
25	4	21426-0003	LOCKWASHER, 5/16" SS

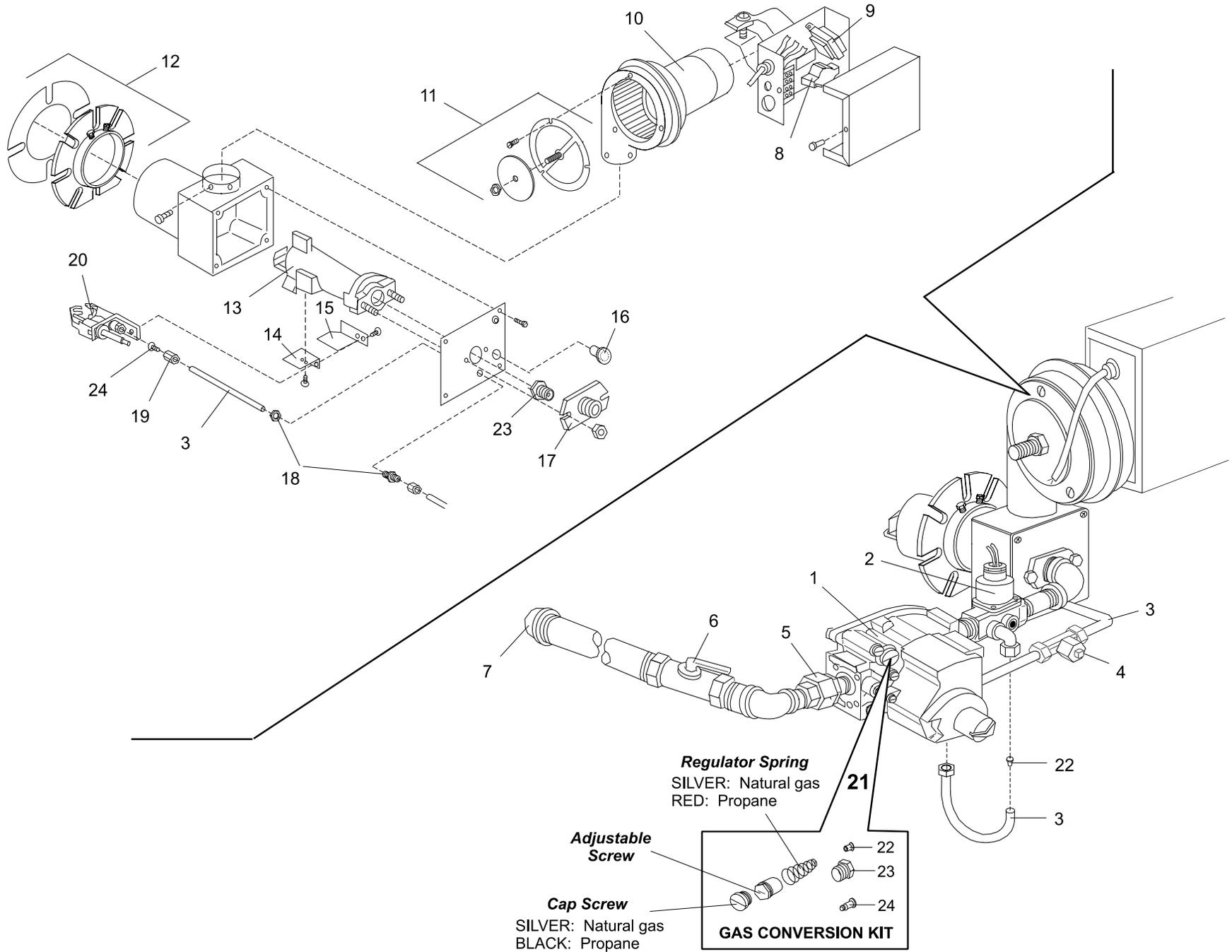

X. GAS BURNER SYSTEM

<i>ITEM</i>	<i>QTY.</i>	<i>PART NO.</i>	<i>DESCRIPTION</i>
1	1	42810-0121	GAS CONTROL VALVE, 1/2"
2	1	28091-0017	SOLENOID VALVE
3	A/R	15125-0002	TUBING, ALUMINUM, 1/4" DIA., 1 FT.
4	1	30185	KIT, PILOT PRESSURE TAP (PILOT TEE)
5	1	23051-0003	UNION, 1/2"
6	1	23115-0010	GAS VALVE, MANUAL, 3/4" I.D.
7	1	22564-0011	CAP PLUG
8	1	27170-0016	MOTOR RELAY
9	1	27170-0017	TRANSFORMER, 120/24V
10	1	27170-0011	MOTOR, BURNER BLOWER
11	1	42810-0087	KIT, EXTERNAL AIR SHUTTER
12	1	36562	KIT, BURNER MOUNTING RING
13	1	27170-0223	VENTURI ASSEMBLY
14	1	27170-0264	BRACKET, PILOT IGNITOR
15	1	27170-0204	SHIELD, PILOT
16	1	38280	WINDOW PLUG
17	1	38279	MAIN ORIFICE HOLDER/GAS INLET CONNECTOR
18	1	23052-0007	FITTING, PILOT BULKHEAD
19	1	38284	FITTING, PILOT TUBING
20	1	42810-0117	KIT, PILOT IGNITOR ASSEMBLY
21	--	42810-0119	KIT, GAS CONVERSION, NATURAL TO PROPANE
21	--	42810-0120	KIT, GAS CONVERSION, PROPANE TO NATURAL
22	1	22174-0006	ORIFICE, LOW FLAME #53 - NATURAL
22	1	22174-0009	ORIFICE, LOW FLAME #62 - PROPANE
23	1	22176-0004	ORIFICE, MAIN, 0.219" - NATURAL
23	1	22176-0003	ORIFICE, MAIN, 0.134" - PROPANE
24	1	22174-0011	ORIFICE, PILOT, 0.028" - NATURAL
24	1	22174-0010	ORIFICE, PILOT, 0.018" - PROPANE

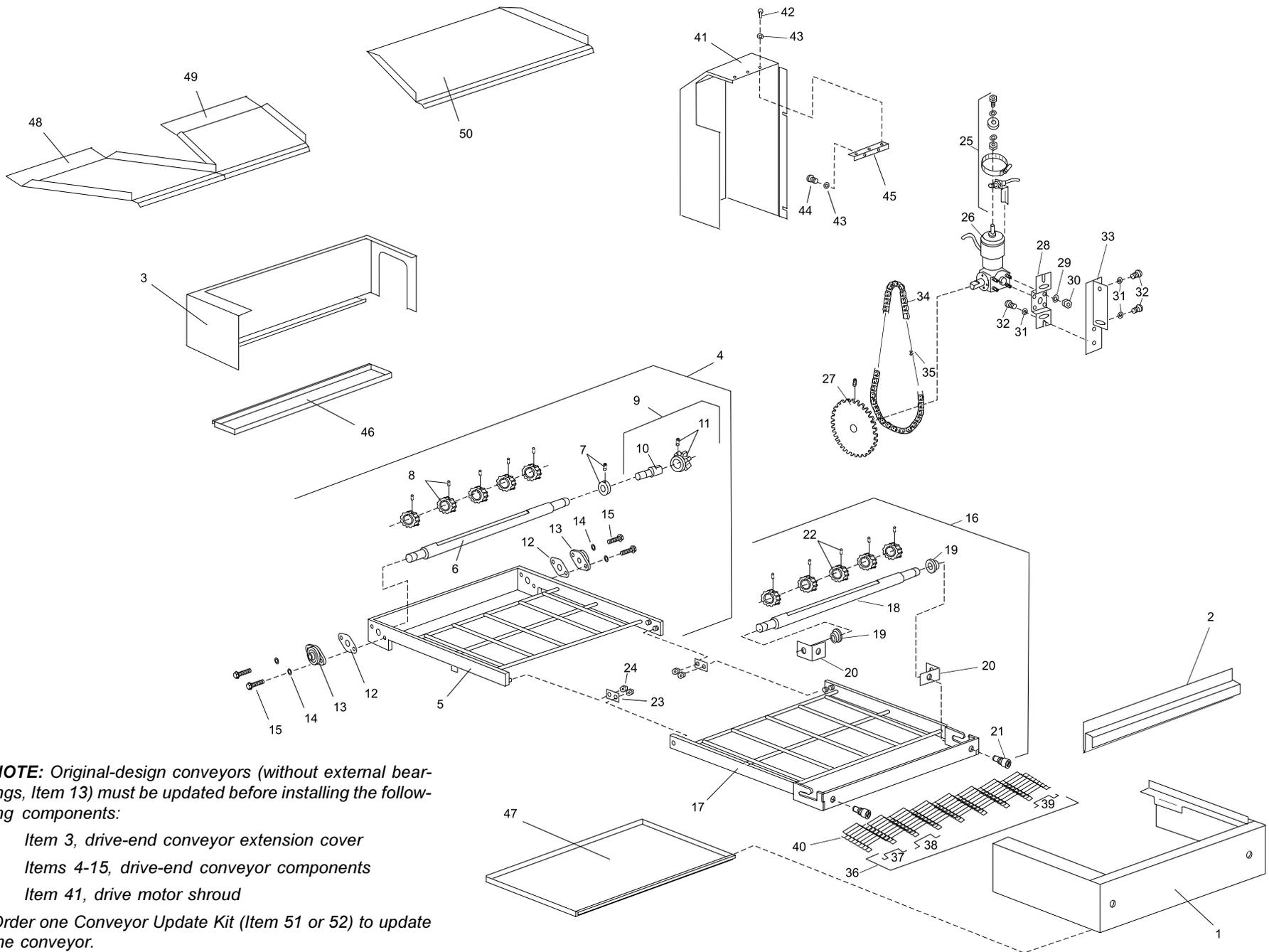

NOTE: Original-design conveyors (without external bearings, Item 13) must be updated before installing the following components:

- Item 3, drive-end conveyor extension cover
- Items 4-15, drive-end conveyor components
- Item 41, drive motor shroud

Order one Conveyor Update Kit (Item 51 or 52) to update the conveyor.

XI. CONVEYOR ASSEMBLY

ITEM	QTY.	PART NO.	DESCRIPTION	ITEM	QTY.	PART NO.	DESCRIPTION
1	1	35096	COVER, CONVEYOR EXTENSION, IDLER	34	1	35408	ROLLER CHAIN, 68 LINKS
2	1	35000-1099	CONVEYOR END STOP, IDLER	35	1	22273-0001	CONNECTING LINK, ROLLER CHAIN
3	1	35000-1694	COVER, CONVEYOR EXTENSION, DRIVE	36A	1	NOT AVAILABLE	MASTER LINKS KIT, 24"/610mm BELT (INC. ITEMS 37A-39A)
4	1	41852	CONVEYOR ASSEMBLY, DRIVE (INC. ITEMS 5-15)	37A	1	33900-0016	MASTER LINK, RIGHT, 24"/610mm BELT
5	1	37000-0670	CONVEYOR FRAME, DRIVE	38A	3	33900-0017	MASTER LINK, MIDDLE, 24"/610mm BELT
6	1	41745	CONVEYOR DRIVE SHAFT	39A	1	33900-0018	MASTER LINK, LEFT, 24"/610mm BELT
7	1	22011-0013	SHAFT COLLAR W/SETSCREW	36B	1	42467	MASTER LINKS KIT, 23"/584mm BELT (INC. ITEMS 37B-39B)
8	5	22229-0003	CONVEYOR SPROCKET W/SET SCREW	37B	1	42465	MASTER LINK, RIGHT, 23"/584mm BELT
--	5	21276-0039	SET SCREW, SOCKET, 1/4-28 X 1/2" (INC. W/ITEM 8)	38B	3	42466	MASTER LINK, CENTER, 23"/584mm BELT
9	1	41851	DRIVE SPROCKET ASSEMBLY (INC. ITEMS 10-11)	39B	1	42464	MASTER LINK, LEFT, 23"/584mm BELT
10	1	41746	DRIVE SHAFT ADAPTER	40A	1	22450-0009	CONVEYOR BELT, 24 X 174" (610 X 4420mm)
11	1	22152-0017	SPROCKET, 9T, W/SET SCREW	40B	--	33900-0035	CONVEYOR BELT, 24 X 12" (610 X 305mm)
--	1	21265-0023	SET SCREW, SKT, #10-24 x 5/16" (INC. W/ITEM 11)	40C	1	37782	CONVEYOR BELT, 23 X 180" (584 X 4572mm)
12	2	41744	FLANGE PLATE	40D	--	NOT AVAILABLE	CONVEYOR BELT, 23 X 12" (584 X 305mm)
13	2	41843	BEARING, DRIVE SHAFT	41	1	35342	DRIVE MOTOR SHROUD
14	4	2001805	LOCKWASHER, SPLIT 3/8"	42	3	21296-0003	WING SCREW, 1/4"-20 x 1/2"
15	5	2000531	SCREW, CAP HEX HD 3/8"-16 X 1"	43	5	21411-0003	FLAT WASHER, 9/32" ID X 5/8" OD
16	1	35089	CONVEYOR ASSEMBLY, IDLER (INC. ITEMS 17-22)	44	2	21211-0003	CAP SCREW, HEX HD, 1/4"-20 x 1/2"
17	1	34974	CONVEYOR FRAME, IDLER	45	1	35051	SUPPORT, CONVEYOR MOTOR SHROUD
18	1	35900-0422	CONVEYOR IDLER SHAFT	46	1	35000-1689	CRUMB PAN, LEFT
19	2	22034-0003	BUSHING, BRONZE, 5/8" ID X 3/4" OD X 1/2" L	47	1	35093	CRUMB PAN, RIGHT
20	2	37000-0413	BRACKET, CONVEYOR TENSION ADJUSTMENT	48	1	35226	EXIT TRAY, RIGHT (DOUBLE-TRAY OVEN)
21	2	35000-1008	SCREW, CONVEYOR TENSION ADJUSTMENT	49	1	35343	EXIT TRAY, LEFT (DOUBLE-TRAY OVEN)
22	5	22229-0003	CONVEYOR SPROCKET W/SET SCREW	50	1	35333	EXIT TRAY (SINGLE-TRAY OVEN)
--	5	21276-0039	SET SCREW, SKT, 1/4-28 X 1/2" (INC. W/ITEM 22)	<i>NOT SHOWN:</i>			
23	2	35900-0169	PIVOT PLATE, CONVEYOR FRAME	51	--	41927	SERVICE KIT, PS314SBI CONVEYOR UPDATE This Kit updates one original-design PS314SBI conveyor assembly to the current design shown in this parts manual. Kit includes all necessary parts and instructions for the update.
24	4	21176-0001	LOCK NUT, HEX, 1/4-20				
25	1	27170-0263	PICKUP ASSEMBLY, CONVEYOR DRIVE MOTOR				
26	1	27384-0003	CONVEYOR DRIVE MOTOR (RATIO: 600 TO 1)				
--	2	22450-0052	BRUSH, CONVEYOR DRIVE MOTOR (INC. W/ITEM 26)				
27	1	22152-0022	CHAIN SPROCKET - 30T, WITH SET SCREW				
--	1	--	SET SCREW, 5/16-10 x 1" (INC. W/ITEM 27)				
28	1	35000-1021	MOUNTING BRACKET, CONVEYOR DRIVE MOTOR				
29	4	21411-0003	FLAT WASHER, 9/32" ID X 5/8" OD	52	--	42564	SERVICE KIT, PS314SBI CONVEYOR AND BELT UPDATE This Kit includes all of the parts for Kit 41927, and also includes Items 36B and 40C (23"/584mm conveyor belt and master links) from the parts listing above. Kit includes all necessary parts and instructions for the update.
30	4	21121-0004	NUT, HEX, 10-24				
31	4	21426-0002	LOCKWASHER, 1/4"				
32	4	21211-0058	CAP SCREW, HEX HD, 3/8-20 X 5/8"				
33	1	35341	MOUNTING WELDMENT, CONVEYOR MOTOR				

23

WARNING

Improper installation, adjustment, alteration, service or maintenance can cause property damage, injury or death. Read the installation, operating and maintenance instructions thoroughly before installing or servicing this equipment.

NOTICE

During the warranty period, ALL parts replacement and servicing should be performed by your Middleby Marshall Authorized Service Agent. Service that is performed by parties other than your Middleby Marshall Authorized Service Agent may void your warranty.

NOTICE

Using any parts other than genuine Middleby Marshall factory manufactured parts relieves the manufacturer of all warranty and liability.

NOTICE

Middleby Marshall reserves the right to change specifications at any time.

PS314SBI

Middleby Cooking Systems Group • 1400 Toastmaster Drive • Elgin, IL 60120 • USA • (847)741-3300 • FAX (847)741-4406

24-Hour Service Hotline: 1-(800)-238-8444

www.middleby.com

