

PS360EWB

PS360EWB Gas Ovens

Models:

- PS360EWB

PARTS MANUAL

for domestic and standard export ovens

© 2000 Middleby Marshall, Inc.

 **Middleby
Marshall®** is a registered trademark of Middleby Marshall, Inc. All rights reserved.

Middleby Cooking Systems Group • 1400 Toastmaster Drive • Elgin, IL 60120 • (847)741-3300 • FAX (847)741-4406

TABLE OF CONTENTS

<i>Section</i>	<i>Page</i>
I. Key Spare Parts Kit	3
II. Installation Kit	4
III. Bake Compartment, Window And Panels	6
IV. Shrouds And Vents	8
V. Machinery Compartment	10
VI. Control Panel And Door Assemblies	12
VII. Gas Burner And Piping Assembly - <i>Burner Configuration A</i>	14
VIII. Gas Burner And Piping Assembly - <i>Burner Configuration B</i>	16
IX. Single Conveyor	18
X. 50-50 Split Belt Conveyor	20
XI. 1/3-2/3 Split Belt Conveyor	22
XII. Upper Oven Stand	24

NOTE: Throughout this Parts Manual, the following abbreviations are used:

A/R = Quantity As Required

N/A = Does Not Apply

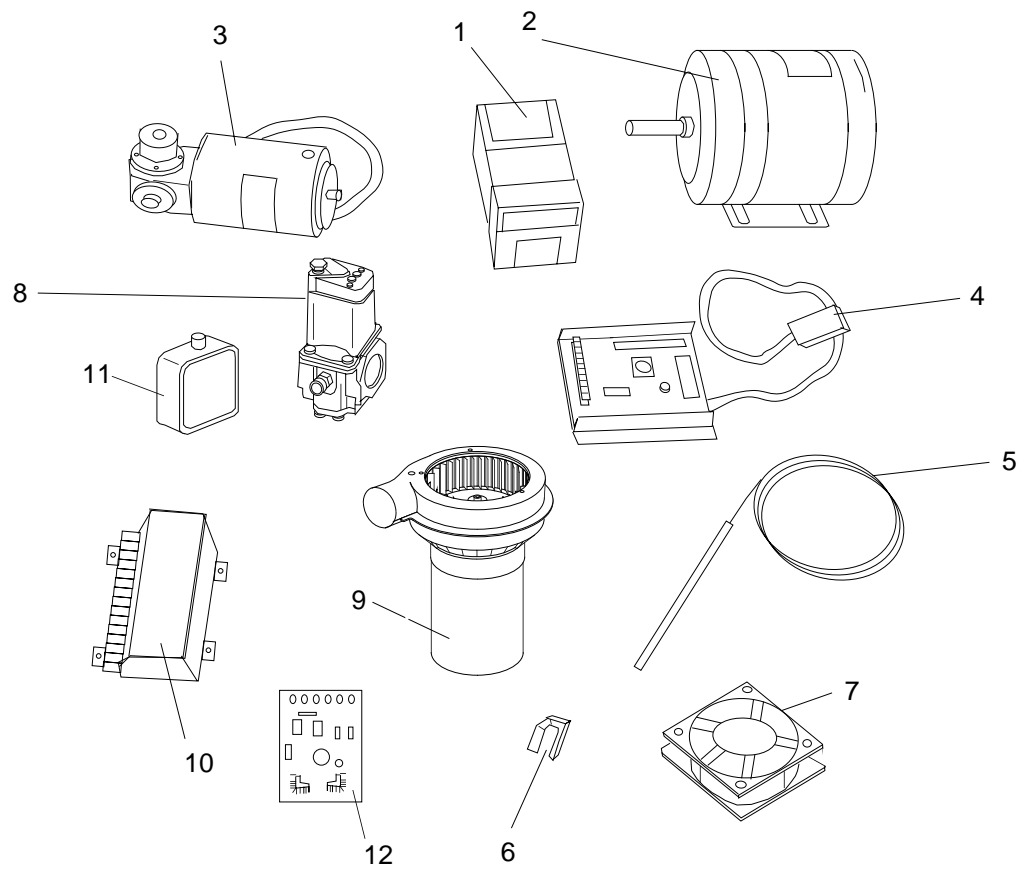

I. KEY SPARE PARTS KIT

<i>ITEM</i>	<i>PART NO.</i>	<i>QTY.</i>	<i>DESCRIPTION</i>
1	36939	1	TEMPERATURE CONTROLLER
2	33720	1	BLOWER MOTOR, 1 HP (1 PH)
3	27384-0008	1	CONVEYOR DRIVE MOTOR
4	42810-0133	1	CONVEYOR SPEED CONTROLLER
5	33984	1	THERMOCOUPLE
6	22450-0052	2	CONVEYOR DRIVE MOTOR BRUSHES
7	36451	1	COOLING FAN
8	32570	1	MODULATING VALVE (FOR NATURAL AND PROPANE OVENS)
9	38811	1	BURNER MOTOR/BLOWER ASSEMBLY
10	27161-0005	1	IGNITION MODULE (NATURAL AND PROPANE)
11	32102	1	AIR SWITCH
12	31651	1	MODULATING VALVE AMPLIFIER

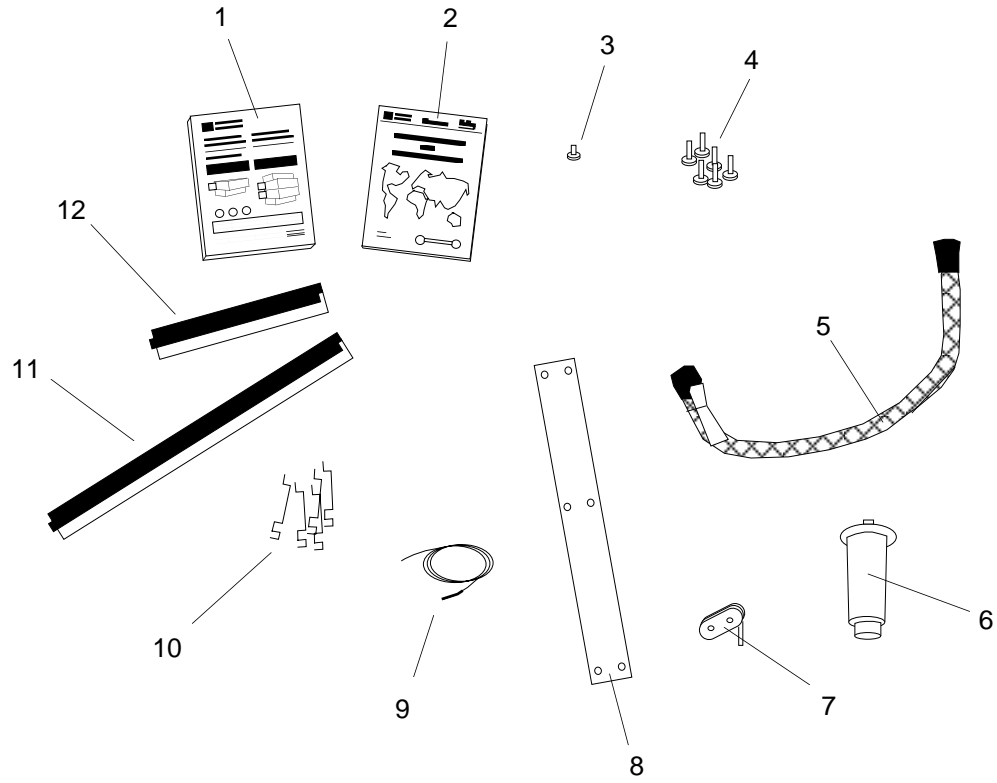

II. INSTALLATION KIT

ITEM	PART NO.	DESCRIPTION	QTY.		
			Single-belt	50-50splitbelt	1/3-2/3splitbelt
1	34640	OWNER'S OPERATING MANUAL (ENG/FR)	1	1	1
2	1002040	AGENCY LISTING/DISTRIBUTOR GUIDE	1	1	1
3	21256-0008	SCREW, 10-32 X 3/8"	1	1	1
4	21292-0001	SCREW, #2PT 10-16 X 3/4" HEX WASHER	A/R	A/R	A/R
5	12361-0001	GAS HOSE, FLEXIBLE	1	1	1
6	22450-0028	LEG, 6" (152mm), ADJUSTABLE	4	4	4
7	27170-0238	HEX KEY SET	1	1	1
8	35122-0049	ATTACHMENT STRIP (UPPER OVEN KIT ONLY)	2	2	2
9	33984	THERMOCOUPLE	1	1	1
10	34078	MASTER LINKS KIT FOR 44" (1118mm) BELT	1	-	-
10	35472	MASTER LINKS KIT FOR 21" (533mm) BELT	-	2	-
10	36766	MASTER LINKS KIT FOR 28" (711mm) BELT	-	-	1
10	35482	MASTER LINKS KIT FOR 14" (356mm) BELT	-	-	1
11	35900-0370	CONVEYOR END STOP	2	2	-
11	35509	CONVEYOR END STOP	-	-	1
12	35900-0148	CONVEYOR REAR STOP	1	1	-
12	35900-1099	CONVEYOR REAR STOP	-	-	1

NOTE: Contents of the installation kit may vary according to individual customer preferences.

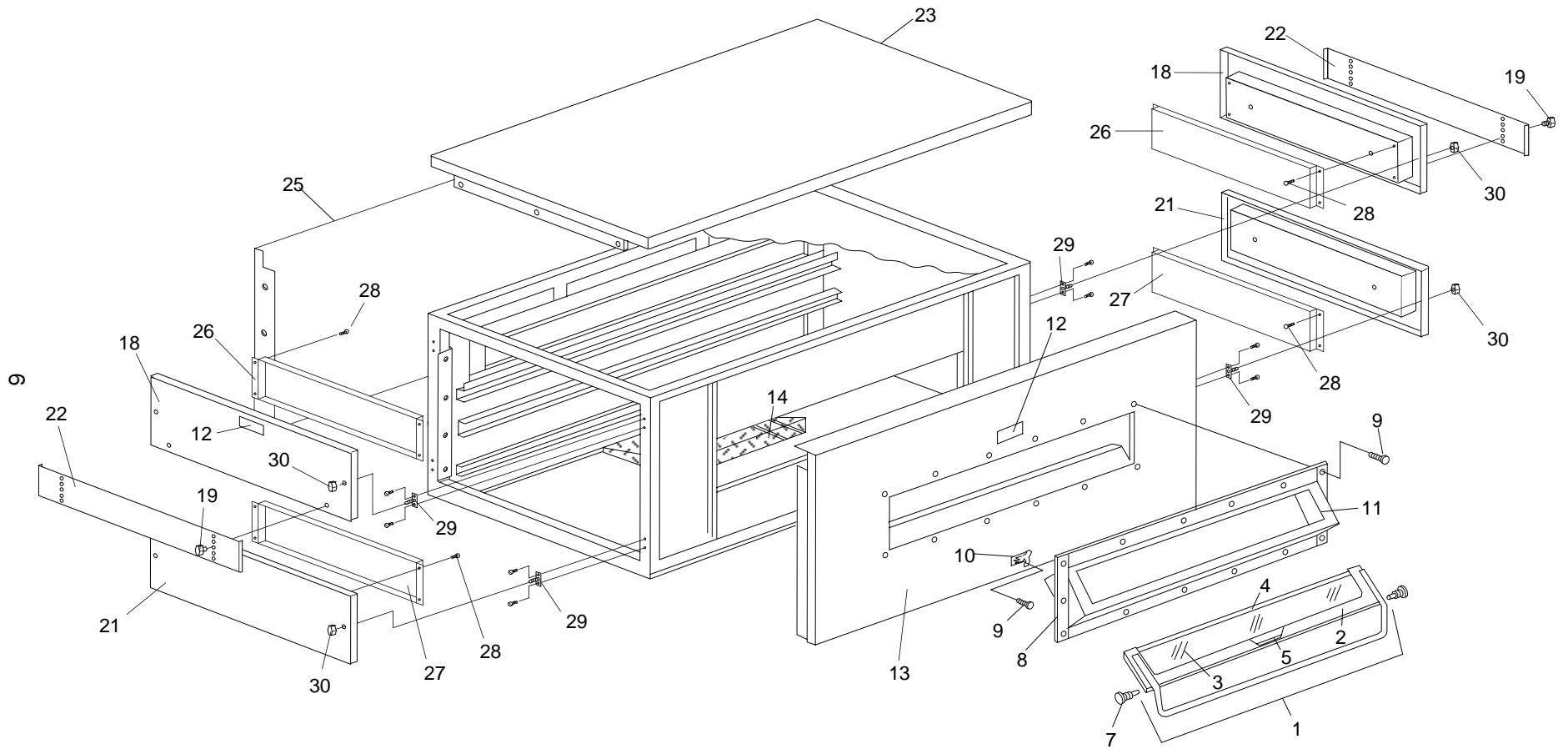

III. BAKE COMPARTMENT, WINDOW AND PANELS

<i>ITEM</i>	<i>QTY.</i>	<i>PART NO.</i>	<i>DESCRIPTION</i>
1	1	42400-0156	GLASS FRAME/HANDLE ASSEMBLY
2	1	37115-0136	GLASS FRAME/HANDLE WELDMENT
3	1	22140-0012	GLASS
4	1	35000-1025	TOP FRAME
5	A/R	17130-0006	SILICONE - ADH. SEAL
7	2	34121-0003	SCREW - THUMB PIVOT
8	1	37000-0371	WINDOW/MTG FRAME WELDMENT
9	14	31451	SCREW 6/32 X 5/8"
10	1	42400-0087	LATCH ASSEMBLY
11	A/R	22420-0005	WINDOW GASKET
12	3	30631	CAUTION LABEL
13	1	31403	FRONT PANEL, OUTER, LOWER OVEN
13	1	31404	FRONT PANEL, OUTER, UPPER OVEN
14	1	32220	SCREEN GUARD (Option) BURNER CHAMBER
18	2	36879	UPPER END PLUG
19	4	33719	WING SCREW, BLACK
21	2	36880	LOWER END PLUG
22	2	33349	EYEBROW
23	1	31943	TOP PANEL (LOWER SINGLE OVEN ONLY)
23	1	31641	TOP PANEL (UPPER OVEN)
24	A/R	22131-0004	INSULATION 1" (25mm) INSIDE OF ALL TOP, FRONT AND REAR PANELS (NOT SHOWN)
25	1	31402	REAR PANEL
26	2	36864	END PLUG EXTENSION CAP, UPPER
27	2	36865	END PLUG EXTENSION CAP, LOWER
28	16	21292-0001	SCREW, 10-16 X 3/4"
29	8	36448	END PLUG MOUNTING PLATE ASSEMBLY
30	8	36452	WING NUT, BLACK PLASTIC, 1/4-20

7

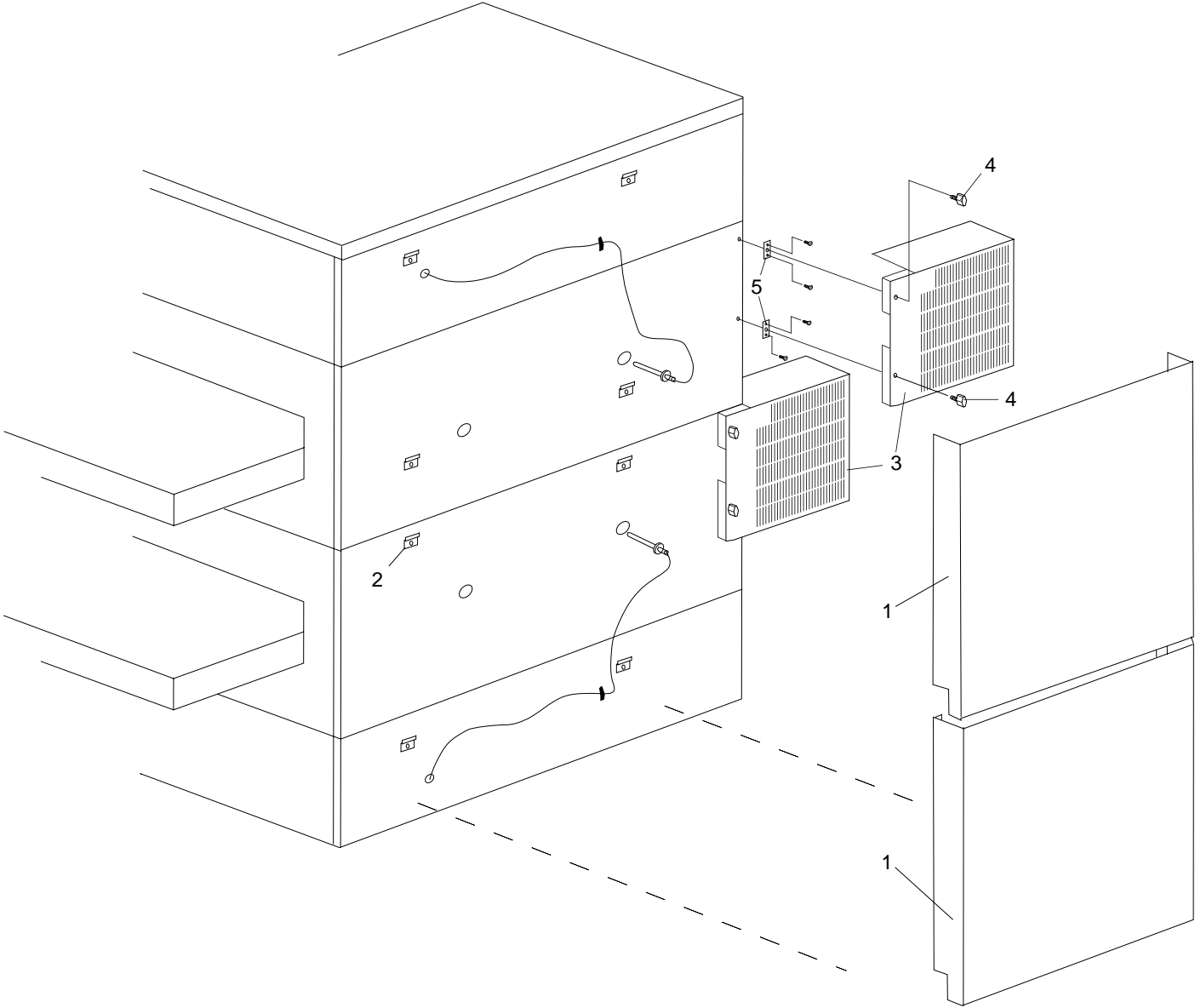

IV. SHROUDS AND VENTS

<i>ITEM NO.</i>	<i>QTY- SGL. OVEN</i>	<i>QTY- DBL. OVEN</i>	<i>PART NO.</i>	<i>DESCRIPTION</i>
1	1	2	31495	REAR SHROUD, 2" (51mm)
1	1	2	32137	REAR SHROUD, 5" (127mm)
2	4	8	35000-1622	HANGER, REAR SHROUD
3	1	2	34666	UTILITY SHROUD ASSEMBLY
4	2	4	36452	WING NUT, BLACK PLASTIC, 1/4-20
5	2	4	36448	END PLUG MOUNTING PLATE ASSEMBLY

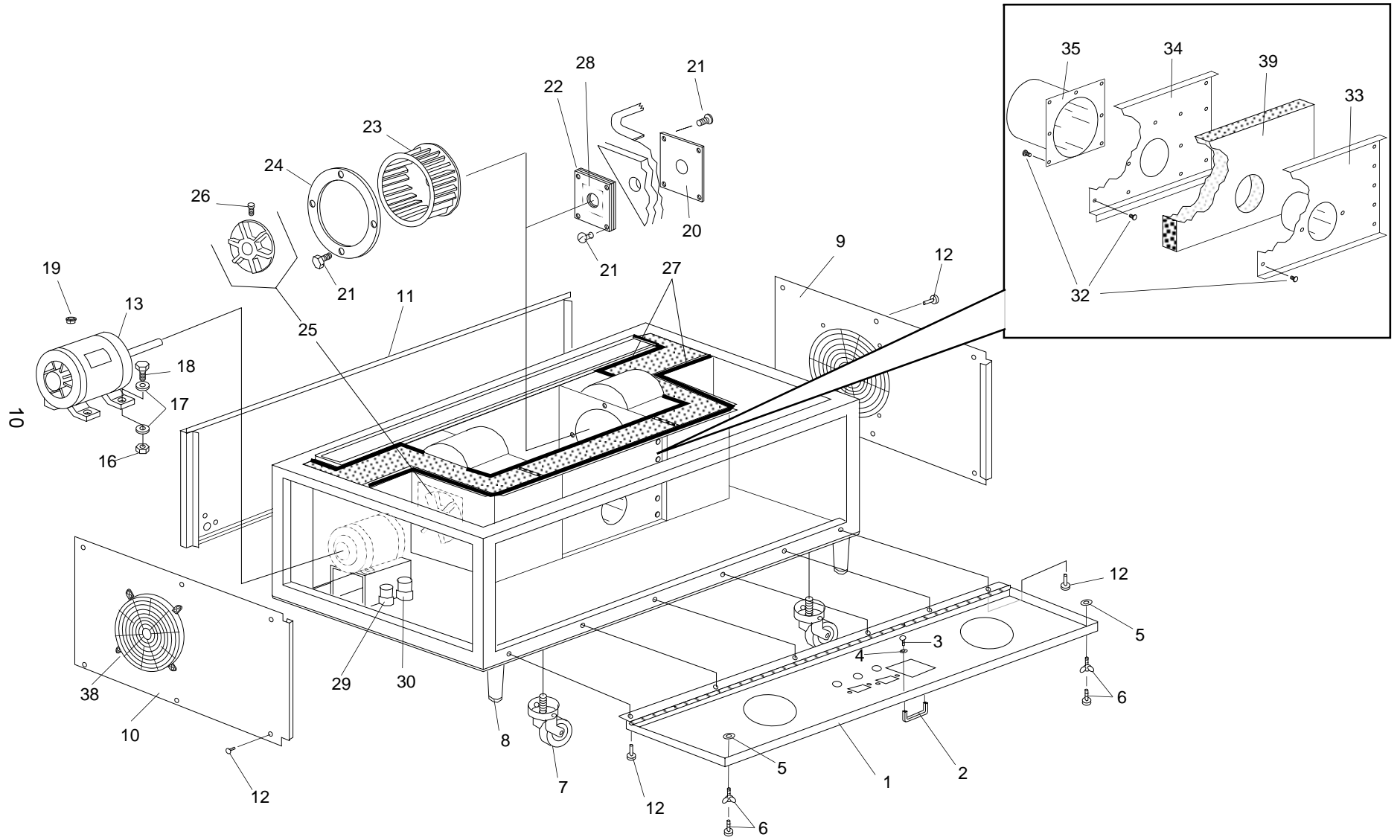

V. MACHINERY COMPARTMENT

ITEM	QTY.	PART NO.	DESCRIPTION	ITEM	QTY.	PART NO.	DESCRIPTION
1	1	31859	CONTROL DOOR	23	1	35604	COUNTERCLOCKWISE BLOWER WHEEL, 9-1/8" (235mm) Dia. x 4-1/2" (114mm) W x 7/8" (22mm) B - For Standard PS360EWB (RH Side Of Lower Oven, LH Side Of Upper)
2	1	33721	CONTROL DOOR HANDLE				
3	2	2000177	SCREW, 10-32 x 1/8"				
4	2	2001740	LOCK WASHER				
5	2	21186-0010	RETAINER	23	1	36014	CLOCKWISE BLOWER WHEEL, 8-1/4" (210mm) Dia. x 4-1/2" (114mm) W x 7/8" (22mm) B - For Model PS360EWB-Q <u>Only</u> (LH Side Of Lower Oven, RH Side Of Upper)
6	2	21296-0006	WING SCREW				
7	4	37115-0102	CASTER				
8	4	22450-0028	ADJUSTABLE LEG				
9	1	33342	END PANEL (RIGHT on Lower Oven, LEFT on Upper Oven)	23	1	36015	COUNTERCLOCKWISE BLOWER WHEEL, 8-1/4" (210mm) Dia. x 4-1/2" (114mm) W x 7/8" (22mm) B - For Model PS360EWB-Q <u>Only</u> (RH Side Of Lower Oven, LH Side Of Upper)
10	1	33343	END PANEL (LEFT on Lower Oven, RIGHT on Upper Oven)				
11	1	33728	REAR PANEL	24	2	31601	INLET CONE, For Standard PS360EWB
12	18	31451	SCREW 10-24 x 1/2"	24	2	36022	INLET CONE, For Model PS360EWB-Q <u>Only</u>
13	2	31432	MOTOR, 1 HP, 208/230V, 50/60 Hz, 1 Ph	25	2	27396-0005	HEAT SLINGER ASSEMBLY w/SET SCREW
-	-	17110-0018	ANTI-SEIZE LUBRICANT, 1 oz. (Not shown)	26	2	21276-0039	SET SCREW 1/4-20
16	8	21126-0004	HEX NUT S/S 5/16-18	27	1	22420-0002	GASKET - 21.7 FT.(6.6 M) REQUIRED
17	16	21412-0005	FLAT WASHER 5/16"	28	2	35000-1781	PTFE SEAL
18	8	A3896	HEX CAP SCREW S/S 5/16-18 x 1"	29	2	27170-0269	CAPACITOR, START
19	2	27221-0013	BUSH, SNAP NYLON	30	2	27170-0270	CAPACITOR, RUN
20	2	35000-1780	HEAT SINK PLATE	31	1	33150	BURNER SHIELD
21	A/R	21292-0001	HEX SCREW, #2, 10-16 x 3/4"	32	23	21292-0001	HEX SCREW 10-16 X 3/4"
22	2	37115-0151	INNER SHAFT SEAL WELDMENT	33	1	37627	BURNER MOUNTING PLATE
23	1	35603	CLOCKWISE BLOWER WHEEL, 9-1/8" (235mm) Dia. x 4-1/2" (114mm) W x 7/8" (22mm) B - For Standard PS360EWB (LH Side Of Lower Oven, RH Side Of Upper)	34	1	37612	BURNER INNER MOUNTING PLATE
				35	1	38049	BURNER TUBE
				38	2	33733	GRILL, EXHAUST FAN
				39	1	38166	INSULATION PLUG, PRE-CUT

11

PS360EWB

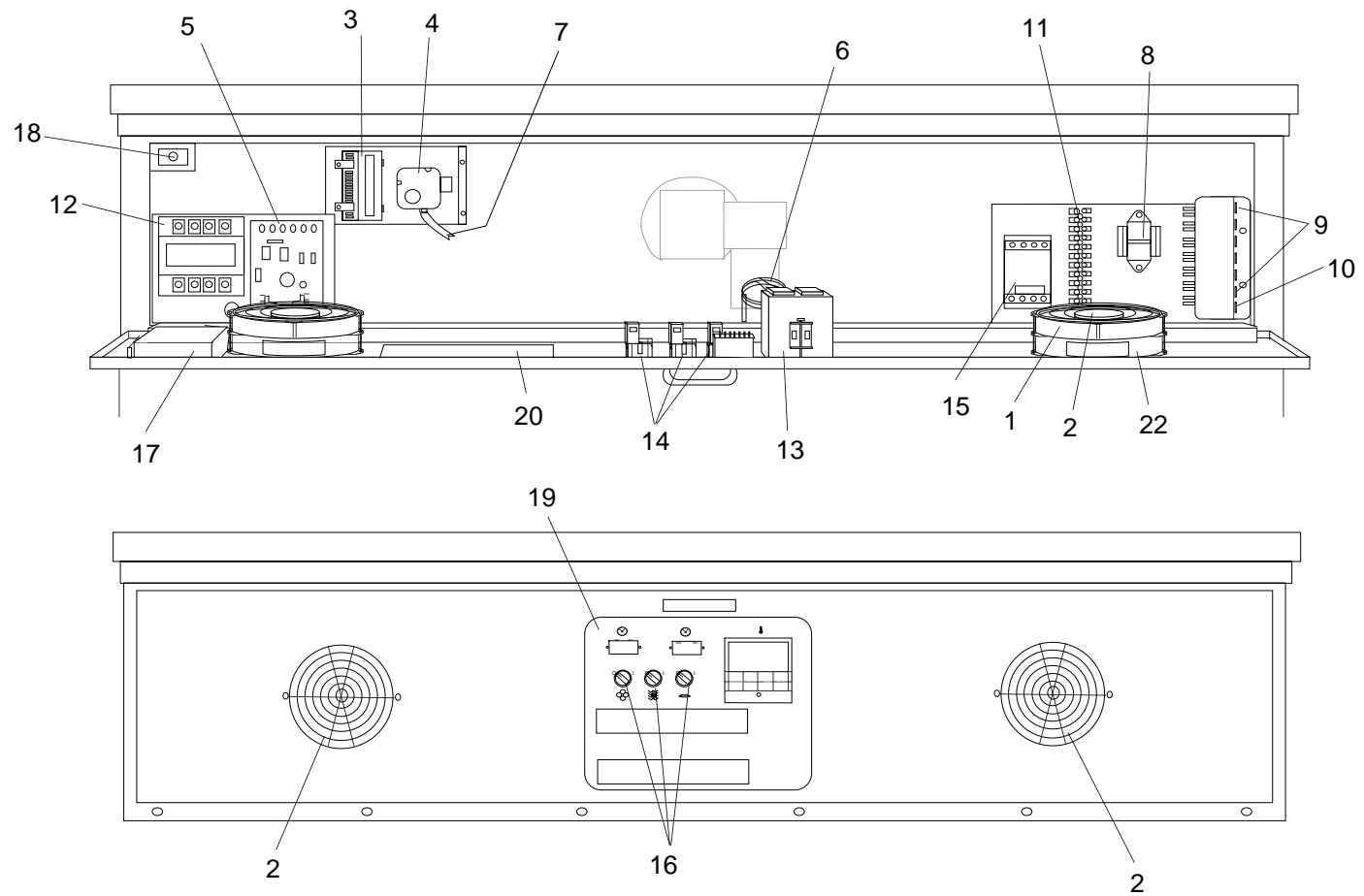

VI. CONTROL PANEL AND DOOR ASSEMBLIES

<i>ITEM</i>	<i>QTY</i>	<i>PART NO.</i>	<i>DESCRIPTION</i>
1	2	31725	COOLING FAN
2	4	33732	GUARD, COOLING FAN
3	1	31501	IGNITION MODULE (BURNER CONFIGURATION A - SEE PP. 10-11)
3	1	27161-0005	IGNITION MODULE (BURNER CONFIGURATION B - SEE PP. 12-13)
4	1	35624	AIR PRESSURE SWITCH
5	1	31651	AMPLIFIER
6	1	33984	THERMOCOUPLE - TYPE J
7	A/R	22450-0297	TUBING, SILICONE RUBBER
8	1	32108	TRANSFORMER
9	6	31498	CIRCUIT BREAKER, 10 AMP
10	1	31503	CIRCUIT BREAKER, 2 AMP
11	1	31499	TERMINAL BLOCK
12	1	31504	TRANSFORMER, 200 VA
13	1	36939	TEMPERATURE CONTROLLER
14	3	27060-0012	CONTACT BLOCK w/BASE 1-NO
15	1	28041-0011	CONTACTOR
16	3	28021-0062	SWITCH SEL. STD. 2 POS.-BLUE
17	1	42810-0133	CONVEYOR SPEED CONTROL, Includes THUMBWHEEL SWITCH
-	1	42810-0118	THUMBWHEEL AND RIBBON CABLE
18	1	28021-0047	DOOR SAFETY SWITCH
19	1	32211	CONTROL FACE PLATE
20	1	31782	LABEL - WIRING DIAGRAM
21	1	34993	TEMPERATURE CONTROLLER BOOST TRANSFORMER (not shown)
22	2	36241	COOLING FAN EXTENSION COLLAR

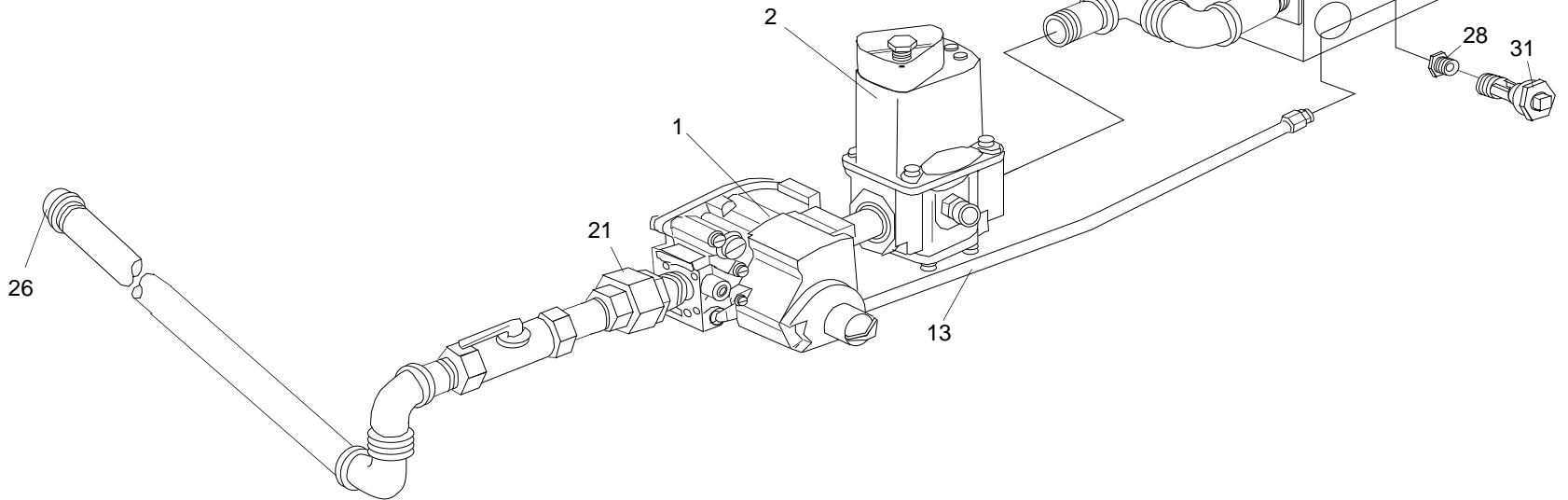
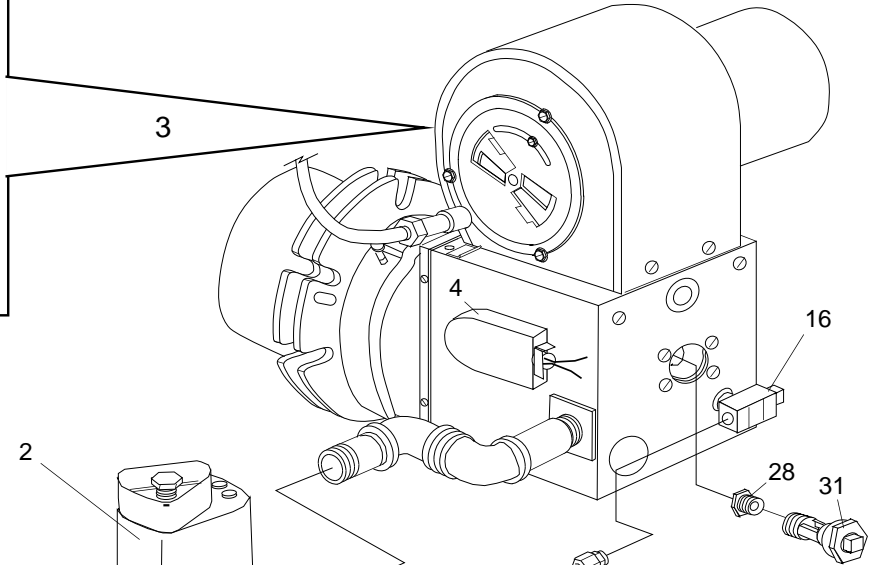
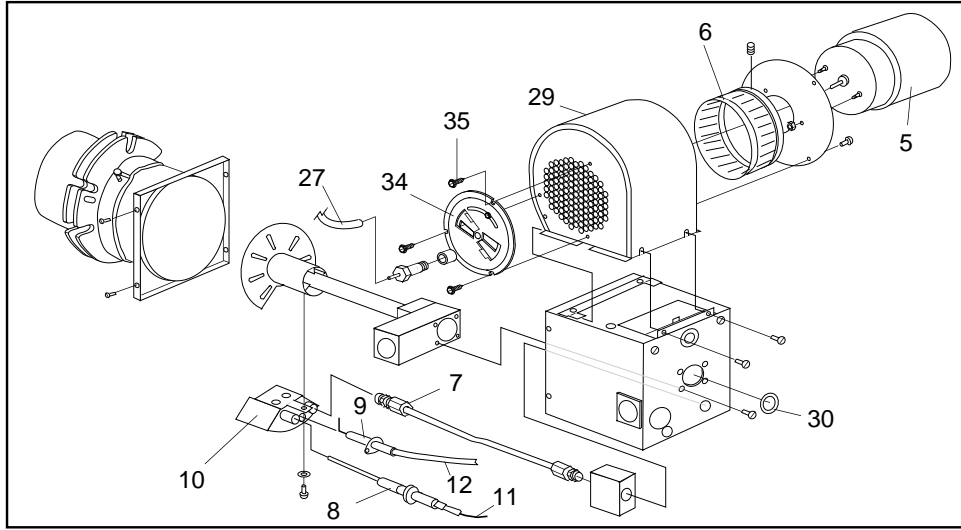

VII. GAS BURNER AND PIPING ASSEMBLY
BURNER CONFIGURATION A

<i>ITEM</i>	<i>PART NO.</i>	<i>QTY</i>	<i>DESCRIPTION</i>
1	32569	1	3/4" GAS CONTROL VALVE
2	32570	1	MODULATING VALVE
3	31441	1	BURNER ASSEMBLY
4	32187	1	CAPACITOR, START
5	32195	1	BURNER MOTOR
6	32194	1	BLOWER WHEEL
7	32193	1	PILOT TUBE
8	32190	1	FLAME SENSOR
9	32191	1	SPARK ELECTRODE
10	35527	1	PILOT ASSEMBLY
11	32188	1	FLAME SENSOR CABLE
12	32189	1	SPARK ELECTRODE CABLE
13	34055	A/R	TUBING, ALUMINUM
16	31818	1	PILOT ORIFICE, NATURAL 0.032"
16	31819	1	PILOT ORIFICE, PROPANE 0.025"
21	23051-0004	1	3/4" UNION
23	23115-0010	1	MANUAL GAS SHUTOFF VALVE
26	22564-0011	1	CAP PLUG
27	22450-0297	A/R	TUBING, SILICONE RUBBER
28	31821	1	ORIFICE, MAIN, NATURAL 0.234"
28	31822	1	ORIFICE, MAIN, PROPANE 0.185"
29	32313	1	BLOWER HOUSING
30	32314	1	GASKET
31	32315	1	ORIFICE HOLDER WITH 1/8" PLUG
34	36830	1	ASSY, SHUTTER PLATE
35	22450-0297	3	SCREW, HEX 10-16 X 1/2"

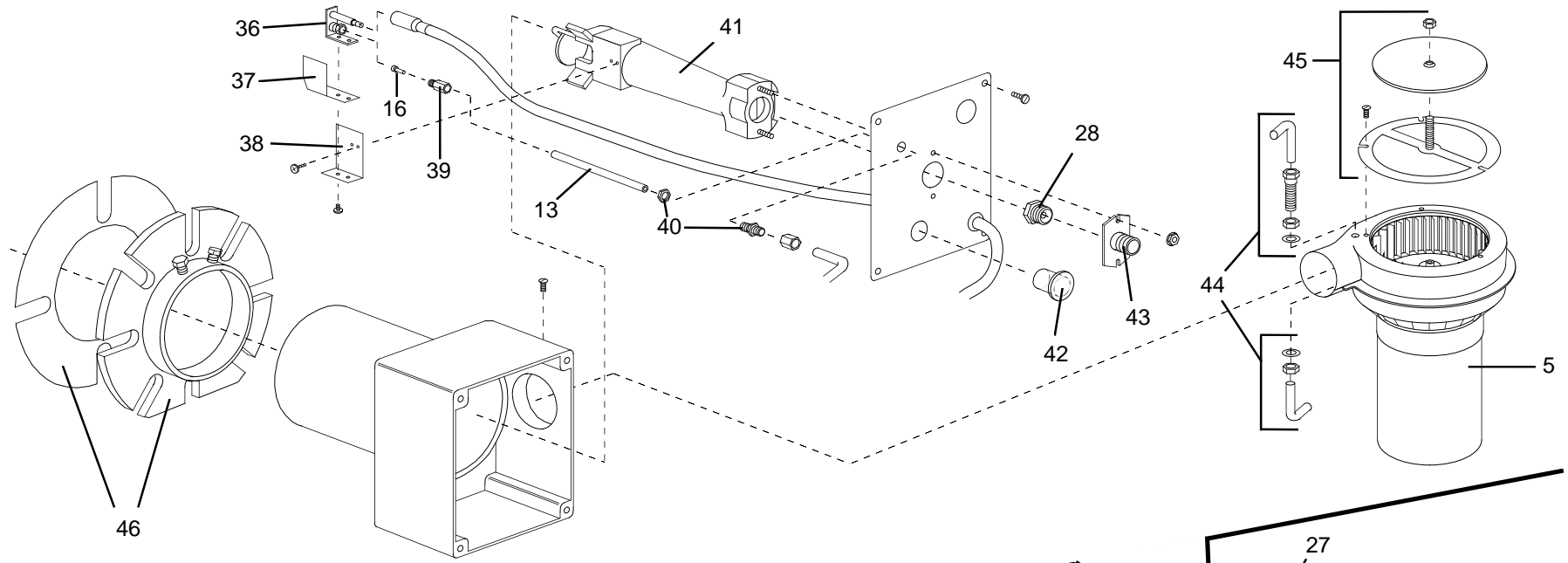

16

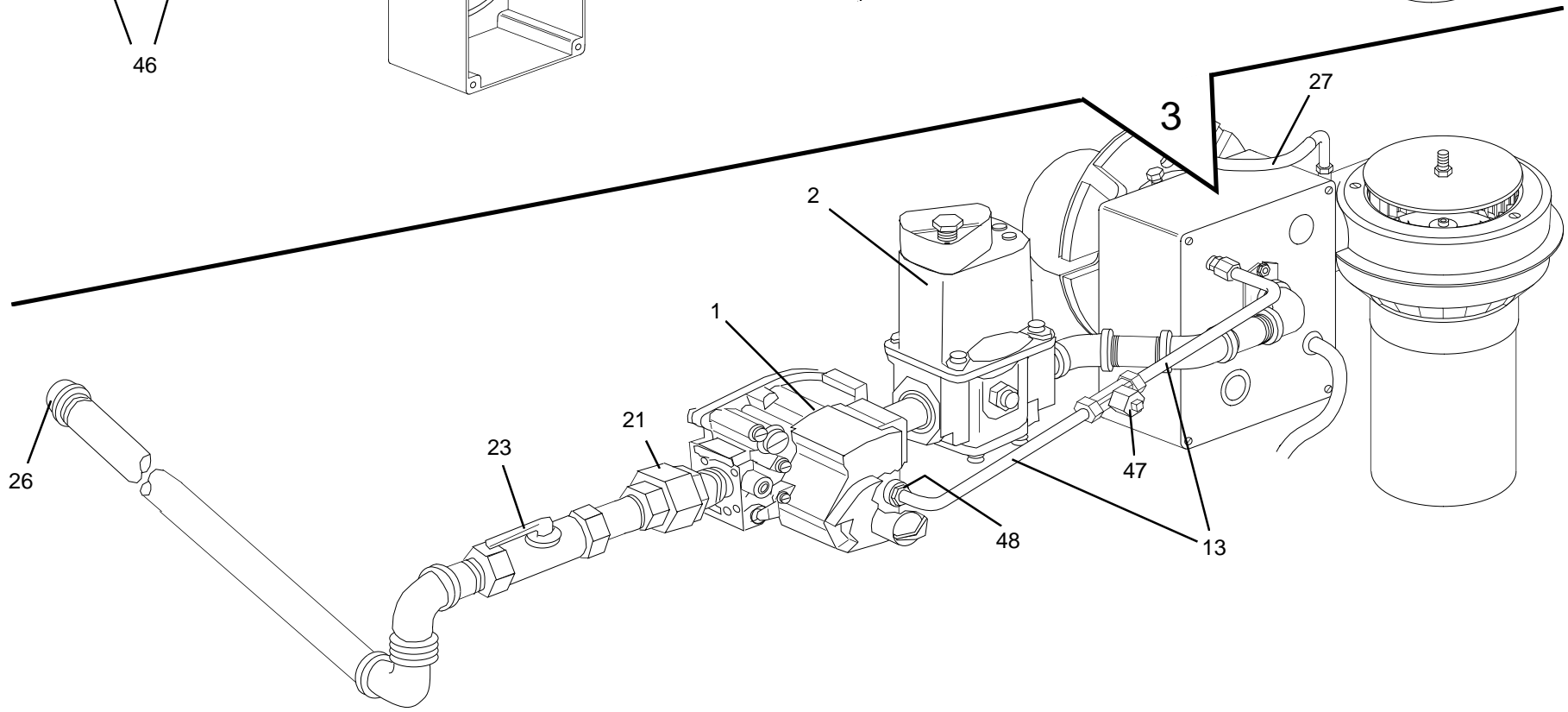

VIII. GAS BURNER AND PIPING ASSEMBLY
BURNER CONFIGURATION B

<i>ITEM</i>	<i>PART NO.</i>	<i>QTY</i>	<i>DESCRIPTION</i>
1	32569	1	3/4" SAFETY REGULATOR (COMBINATION GAS VALVE)
2	32570	1	MODULATING VALVE
3	38126	1	BURNER/BLOWER/MOTOR ASSEMBLY
5	27170-0287	1	BLOWER/MOTOR ASSEMBLY
13	15125-0002	A/R	PILOT TUBING, ALUMINUM, 1 FT. (305mm) LENGTH
16	22174-0011	1	PILOT ORIFICE, NATURAL, 0.028"
16	22174-0010	1	PILOT ORIFICE, PROPANE, 0.018"
21	23051-0004	1	3/4" UNION
23	23115-0010	1	MANUAL GAS SHUTOFF VALVE
26	22564-0011	1	CAP PLUG
27	38290	1	TUBING, SILICONE RUBBER, 24" (610mm)
28	22176-0014	1	MAIN ORIFICE, NATURAL, 0.250"
28	31980	1	MAIN ORIFICE, PROPANE, 0.165"
36	42810-0117	1	PILOT WITH IGNITOR (ASSEMBLY)
37	27170-0204	1	PILOT SHIELD
38	27170-0264	1	PILOT IGNITOR BRACKET (INCLUDED- WITH ITEM 36)
39	38284	1	PILOT TUBING FITTING
40	23052-0007	1	PILOT BULKHEAD FITTING
41	38127	1	VENTURI ASSEMBLY
42	38280	1	WINDOW PLUG
43	38279	1	ORIFICE HOLDER/GAS INLET CONNECTOR
44	42400-0640	1	PILOT TUBE ASSEMBLY
45	42810-0087	1	EXTERNAL AIR SHUTTER KIT
46	36562	1	BURNER MOUNTING RING KIT
47	30001	1	PILOT PRESSURE TAP (PILOT TEE)
48	22352-0004	1	PILOT INLET FITTING

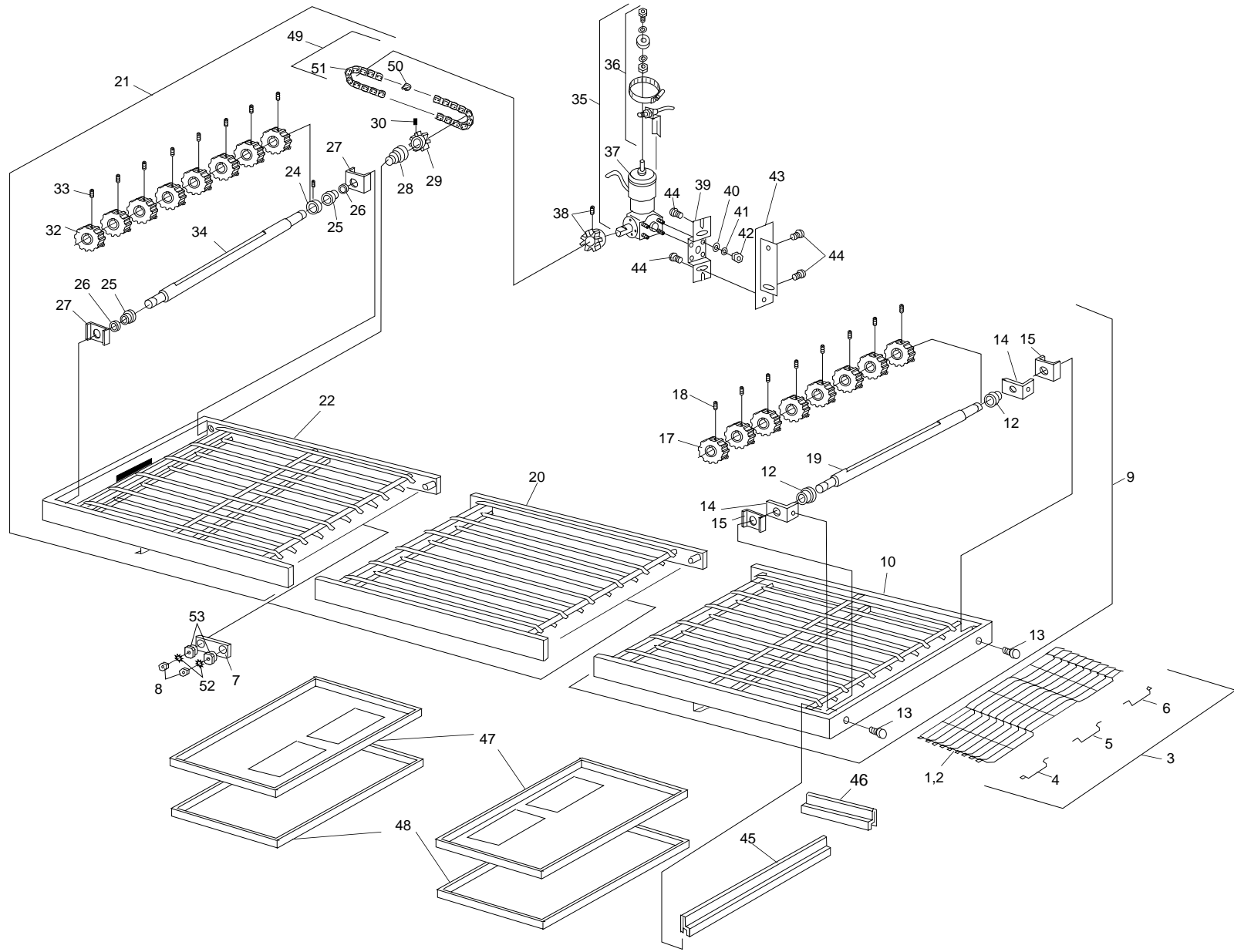

IX. SINGLE CONVEYOR

ITEM	QTY.	PART NO.	DESCRIPTION	ITEM	QTY.	PART NO.	DESCRIPTION
--	--	35349	FOLDING CONVEYOR FRAME ASSEMBLY	31	1	33754	DRIVE SHAFT ASSY. INCLUDES ITEMS 32,33 & 34
1	1	33713	CONVEYOR BELT WIRE SS, 174x44" (4420x1118mm)	32	8	22229-0003	CONVEYOR SPROCKET W/SCREW
2	1	34072	CONVEYOR BELT SECTION WIRE SS, 12" (305mm)	33	8	21276-0039	SPOCKET SET SCREW 1/4-28 x 3/8"
3	1	34078	MASTER LINK KIT INCLUDES ITEMS 4,5 AND 6	34	1	33754	DRIVE SHAFT
4	1	--	MASTER LINK - RIGHT INCLUDED IN ITEM 3	35	1	42400-0477	MOTOR w/PICKUP ASSEMBLY
5	1	--	MASTER LINK - MIDDLE INCLUDED IN ITEM 3	36	1	27170-0263	PICK UP ASSEMBLY ONLY
6	1	--	MASTER LINK - LEFT INCLUDED IN ITEM 3	37	1	27384-0008	REDUCTION GEAR MOTOR
7	4	35210-0429	PIVOT PLATE - CONVEYOR FRAME	--	2	22450-0052	BRUSHES - CONVEYOR DRIVE MOTOR
8	8	21176-0001	LOCKNUT, HEX SS 3/8-20	38	1	22152-0018	CHAIN SPROCKET - 15T w/1/4-20 SET SCR
9	1	33749	CONVEYOR FRAME ASSEMBLY - IDLER	39	1	35000-1021	CONV. MOTOR MOUNTING BRACKET
10	1	33744	CONVEYOR FRAME WELDMENT - IDLER	40	4	21411-0003	FLAT WASHER 1/4" (6.4mm)
12	2	22034-0003	BUSH, FLANGE 3/4" OD, x 5/8" ID	41	4	21426-0002	LOCKWASHER 1/4" (6.4mm)
13	2	35000-1008	BOLT, ADJ - CONVEYOR IDLER	42	4	21126-0009	HEX NUT 1/4-20
14	2	37000-0413	IDLER SHAFT ADJUSTMENT BRACKET	43	1	37000-0427	CONVEYOR MOTOR MOUNTING WELDMENT
15	2	35900-0020	CONVEYOR SHAFT SUPPORT BRACKET	44	4	220373	HEX HD CAP SCREW 3/8-16 x 1"
16	1	33755	IDLER SHAFT ASSEMBLY INCLUDES ITEMS 17,18 & 19	45	2	35900-0370	CONVEYOR END STOP, 20" (508mm) WIDE STOPS
17	8	22229-0003	CONVEYOR SPROCKET W/SCREW	46	1	35900-0148	CONVEYOR LEFT REAR STOP
18	8	21276-0039	SPOCKET SET SCREW 1/4-28 x 3/8"	47	1	34042	CRUMB PAN, LOWER OVEN (SOLID)
19	1	33755	IDLER SHAFT	48	1	34043	CRUMB PAN, UPPER OVEN (W/VENT HOLES)
20	1	33742	CONVEYOR CENTER FRAME WELDMENT	49	1	42400-0163	ROLLER CHAIN ASS'Y - 52 LINKS
21	1	33750	CONVEYOR FRAME ASSEMBLY - DRIVE	50	1	22273-0001	MASTER LINK
22	1	33743	CONVEYOR FRAME WELDMENT - DRIVE	51	1	31000-0037	ROLLER CHAIN - 52 LINKS
24	1	22011-0013	SHAFT COLLAR W/SCREW	52	8	35210-0491	WASHER, EXTERNAL TOOTH
25	2	22034-0003	BUSH, FLANGE 3/4 OD x 5/8 ID	53	8	F716A8805	BUSHING CONVEYOR ADJUSTMENT
26	2	35000-1080	NYLON SPACER				
27	2	35900-0020	CONVEYOR SHAFT SUPPORT BRACKET				
28	1	35000-1013	DRIVE SHAFT ADAPTER				
29	1	22151-0002	ROLLER CHAIN SPROCKET W/SCREW				
30	1	21276-0038	SOCKET SET SCREW 10-32 x 5/16" SS				

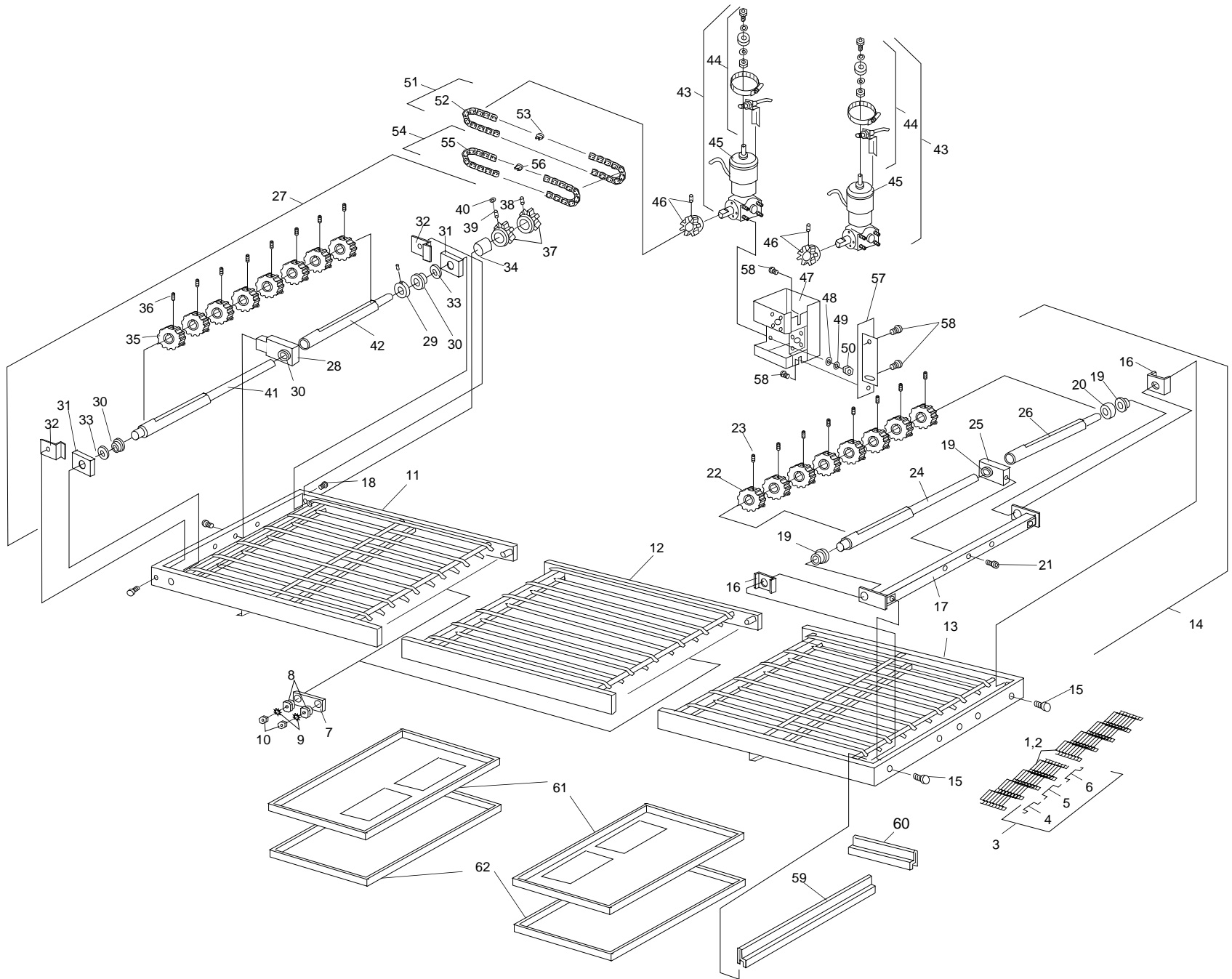

X. 50-50 SPLIT BELT CONVEYOR

ITEM	QTY.	PART NO.	DESCRIPTION	ITEM	QTY.	PART NO.	DESCRIPTION
1	2	33735	CONVEYOR BELT WIRE SS, 174 x 21" (4420x533mm)	37	2	22152-0017	SPROCKET, CONVEYOR DRIVE 9T w/SCREW
2	1	35532	CONVEYOR BELT SECTION WIRE SS, 12 x 21" (305x533mm)	38	1	21266-0009	SKT SET SCREW 10-24 X 5/16" SS.
3	2	35472	MASTER LINK KIT INCLUDES ITEMS 4,5 AND 6	39	1	21276-0049	SKT SET SCREW 10-24 X 1/2" SS.
4	2	35475	MASTER LINK - RIGHT INCLUDED IN ITEM 3	40	1	A3323	NUT, HEX 10-24 SS.
5	4	35474	MASTER LINK - MIDDLE INCLUDED IN ITEM 3	41	1	33759	DRIVE SHAFT ASSEMBLY, FRONT
6	2	35473	MASTER LINK - LEFT INCLUDED IN ITEM 3	42	1	34038	DRIVE SHAFT, REAR
7	4	35210-0429	PIVOT PLATE - CONVEYOR FRAME	43	2	42400-0477	MOTOR w/PICKUP ASSEMBLY
8	8	35210-0491	BUSHING CONVEYOR ADJUSTMENT	44	2	27170-0263	PICKUP ASSEMBLY ONLY
9	8	F716A8805	WASHER, EXTERNAL TOOTH	45	2	27384-0008	REDUCTION GEAR MOTOR
10	8	21176-0001	LOCKNUT, HEX SS 3/8-20	4	4	22450-0052	BRUSHES - CONVEYOR DRIVE MOTOR
11	1	33750	CONVEYOR FRAME WELDMENT - DRIVE	46	2	22152-0018	CHAIN SPROCKET - 15T w/1/4-20 SET SCR
12	1	33742	CONVEYOR FRAME WELDMENT CENTER	47	1	37000-0632	CONV. MOTOR MOUNTING BRACKET
13	1	33749	CONVEYOR FRAME WELDMENT - IDLER	48	8	21411-0003	FLAT WASHER 9/32" (7.1mm)
14	1	--	CONVEYOR ASSEMBLY - IDLER	49	8	21426-0002	LOCKWASHER 1/4" (6.4mm)
15	2	35000-1008	SCREW, IDLER ADJUSTMENT	50	8	B301A8817	HEX NUT 1/4-20
16	2	35900-0020	CONVEYOR SHAFT SUPPORT BRACKET	51	1	42400-0163	ROLLER CHAIN ASS'Y - 52 LINKS
17	2	35451	TUBE, IDLER ADJUSTMENT	52	1	31000-0037	ROLLER CHAIN - 52 LINKS
18	2	21256-0008	SCREW, TRUSS HD, SLT, 10-32 x 3/8"	53	1	22273-0001	MASTER LINK
19	4	22034-0003	BUSHING, FLANGE 3/4 OD, x 5/8 ID	54	1	42400-0160	ROLLER CHAIN ASS'Y - 30 LINKS
20	1	22011-0014	COLLAR, LOCKING w/SET SCREW	55	1	31000-0034	ROLLER CHAIN - 30 LINKS
21	1	21251-0027	SOCKET HEAD SCREW	56	1	22273-0001	MASTER LINK
22	8	22229-0003	CONVEYOR SPROCKET W/SCREW	57	1	37000-0427	CONVEYOR MOTOR MOUNTING WELDMENT
23	8	21276-0040	SOCKET SET SCREW 1/4-28 x 3/8"	58	4	220373	HEX HD CAP SCREW 3/8-16 x 1"
24	1	33760	IDLER SHAFT ASSEMBLY, FRONT	59	1	35900-0370	CONVEYOR END STOP, 20" (508mm) WIDE STOP
25	1	33757	SUPPORT, IDLER SHAFT	60	1	35900-0148	CONVEYOR LEFT REAR STOP
26	1	34039	IDLER SHAFT, REAR	61	2	34042	CRUMB PAN, UPPER OVEN (w/VENT HOLDER)
27	1	--	CONVEYOR ASSEMBLY - DRIVE	62	2	34043	CRUMB PAN, LOWER OVEN (SOLID)
28	1	35395	SUPPORT SHAFT, DRIVE				
29	1	22011-0014	SPLIT SHAFT COLLAR				
30	4	22034-0003	BUSHING, FLANGE 3/4" OD x 5/8" ID				
31	2	35430	SUPPORT, SHAFT BUSHING				
32	2	35450	CLAMP, SUPPORT SHELF BUSHING				
33	2	35000-1080	NYLON SPACER				
34	1	35000-1537	SPROCKET BUSHING				
35	8	22229-0003	CONVEYOR SPROCKET W/SCREW				
36	8	21276-0040	SOCKET SET SCREW 1/4-28 x 3/8"				

21

PS360EWB

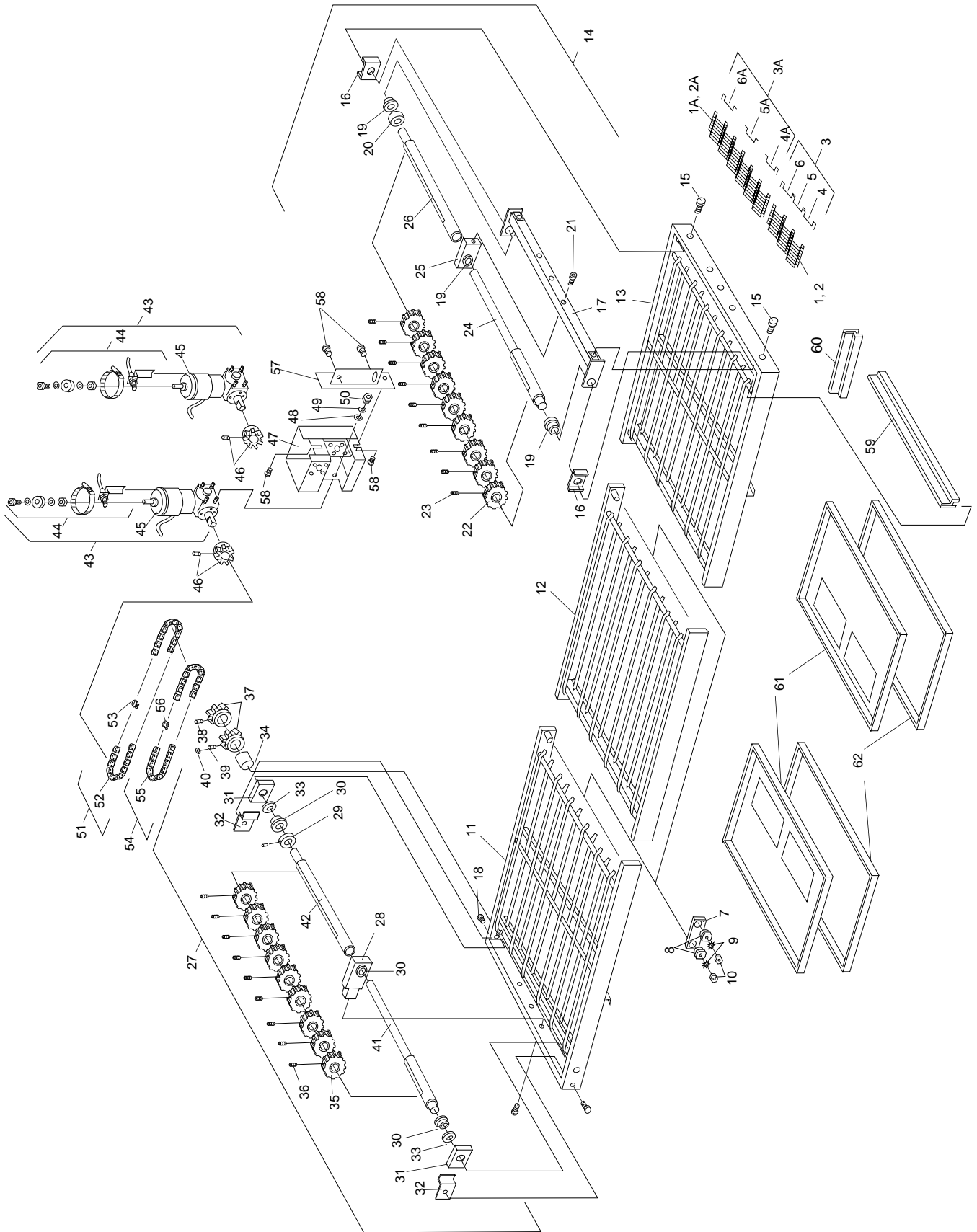

XI. 1/3-2/3 SPLIT BELT CONVEYOR

ITEM	QTY.	PART NO.	DESCRIPTION	ITEM	QTY.	PART NO.	DESCRIPTION
1	1	35315	CONVEYOR BELT WIRE SS, 174 x 14" (4420x356mm)	29	1	22011-0014	SPLIT SHAFT COLLAR
1A	1	35316	CONVEYOR BELT WIRE SS, 174 x 28" (4420x711mm)	30	4	22034-0003	BUSHING, FLANGE 3/4" OD x 5/8" ID
2	1	35609	CONVEYOR BELT SECTION WIRE SS, 12 x 14" (305x356mm)	31	2	35430	SUPPORT, SHAFT BUSHING
2A	1	35610	CONVEYOR BELT SECTION WIRE SS, 12 x 28" (305x711mm)	32	2	35450	CLAMP, SUPPORT SHELF BUSHING
3	1	35482	MASTER LINK KIT, 14" INCLUDES ITEMS 4,5 AND 6	33	2	35000-1080	NYLON SPACER
4	1	35485	MASTER LINK - 14" RIGHT INCLUDED IN ITEM 3	34	1	35000-1537	SPROCKET BUSHING
5	2	35484	MASTER LINK - 14" MIDDLE INCLUDED IN ITEM 3	35	9	22229-0003	CONVEYOR SPROCKET W/SCREW
6	1	35483	MASTER LINK - 14" LEFT INCLUDED IN ITEM 3	36	9	21276-0040	SOCKET SET SCREW 1/4-28 x 3/8"
3A	1	36766	MASTER LINK KIT, 28" INCLUDES ITEMS 4A,5A AND 6A	37	2	22152-0017	SPROCKET, CONVEYOR DRIVE 9T w/SCREW
4A	1	36767	MASTER LINK - 28" RIGHT INCLUDED IN ITEM 3A	38	1	21266-0009	SKT SET SCREW 10-24 X 5/16" SS.
5A	2	36768	MASTER LINK - 28" MIDDLE INCLUDED IN ITEM 3A	39	1	21276-0049	SKT SET SCREW 10-24 X 1/2" SS.
6A	1	35473	MASTER LINK - 28" LEFT INCLUDED IN ITEM 3A	40	1	A3323	NUT, HEX 10-24 SS.
7	4	35210-0429	PIVOT PLATE - CONVEYOR FRAME	41	1	35469	DRIVE SHAFT ASSEMBLY, FRONT
8	8	35210-0491	BUSHING CONVEYOR ADJUSTMENT	42	1	35463	DRIVE SHAFT, REAR
9	8	F716A8805	WASHER, EXTERNAL TOOTH	43	2	42400-0477	MOTOR w/PICKUP ASSEMBLY
10	8	21176-0001	LOCKNUT, HEX SS 3/8-20	44	2	27170-0263	PICKUP ASSEMBLY ONLY
11	1	33750	CONVEYOR FRAME WELDMENT - DRIVE	45	2	27384-0008	REDUCTION GEAR MOTOR
12	1	33742	CONVEYOR FRAME WELDMENT CENTER	4		22450-0052	BRUSHES - CONVEYOR DRIVE MOTOR
13	1	33749	CONVEYOR FRAME WELDMENT - IDLER	46	2	22152-0018	CHAIN SPROCKET - 15T w/1/4-20 SET SCR
14	1	--	CONVEYOR ASSEMBLY - IDLER	47	1	37000-0632	CONV. MOTOR MOUNTING BRACKET
15	2	35000-1008	SCREW, IDLER ADJUSTMENT	48	8	21411-0003	FLAT WASHER 9/32" (7.1mm)
16	2	35900-0020	CONVEYOR SHAFT SUPPORT BRACKET	49	8	21426-0002	LOCKWASHER 1/4" (6.4mm)
17	1	35451	TUBE, IDLER ADJUSTMENT	50	8	21126-0009	HEX NUT 1/4-20
18	2	21256-0008	SCREW, TRUSS HD, SLT, 10-32 x 3/8"	51	1	42400-0163	ROLLER CHAIN ASS'Y - 52 LINKS
19	4	22034-0003	BUSHING, FLANGE 3/4" OD, x 5/8" ID	52	1	31000-0037	ROLLER CHAIN - 52 LINKS
20	1	22011-0014	COLLAR, LOCKING w/SET SCREW	53	1	22273-0001	MASTER LINK
21	1	21251-0027	SOCKET HEAD SCREW	54	1	42400-0160	ROLLER CHAIN ASS'Y - 30 LINKS
22	9	22229-0003	CONVEYOR SPROCKET W/SCREW	55	1	31000-0034	ROLLER CHAIN - 30 LINKS
23	9	21276-0040	SOCKET SET SCREW 1/4-28 x 3/8"	56	1	22273-0001	MASTER LINK
24	1	35468	IDLER SHAFT ASSEMBLY, FRONT	57	1	37000-0427	CONVEYOR MOTOR MOUNTING WELDMENT
25	1	33757	SUPPORT, IDLER SHAFT	58	4	220373	HEX HD CAP SCREW 3/8-16 x 1"
26	1	35465	IDLER SHAFT, REAR	59	1	35509	CONVEYOR END STOP
27	1	--	CONVEYOR ASSEMBLY - DRIVE	60	1	35000-1099	CONVEYOR LEFT REAR STOP
28	1	35395	SUPPORT, DRIVE SHAFT	61	2	34042	CRUMB PAN, UPPER OVEN (W/VENT HOLDER)
				62	2	34043	CRUMB PAN, LOWER OVEN (SOLID)

23

PS360EWB

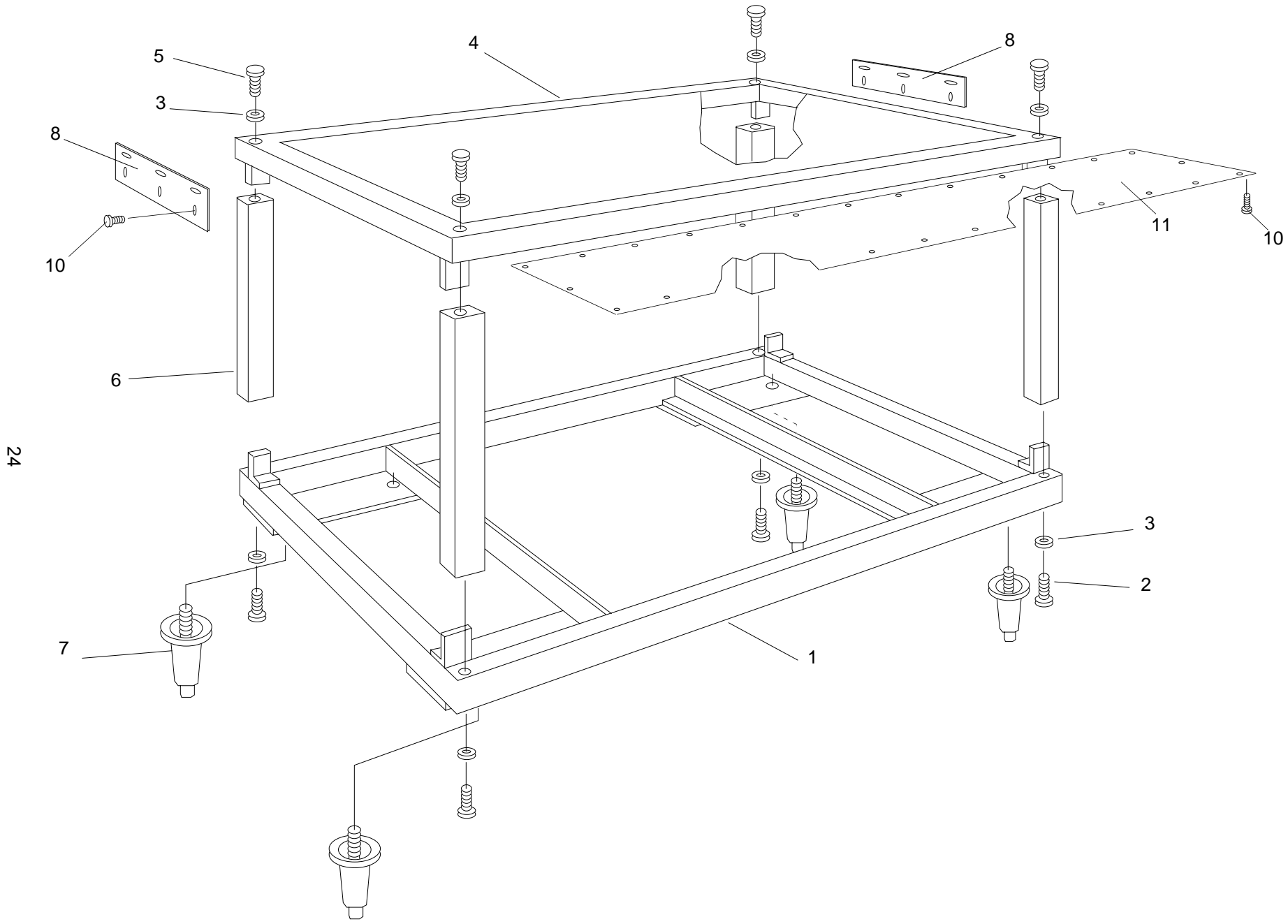

XII. PARTS LIST FOR UPPER OVEN STAND

<i>ITEM NO.</i>	<i>QTY.</i>	<i>PART NO.</i>	<i>DESCRIPTION</i>
N/A	1	38454	UPPER OVEN STAND ASSEMBLY
1	1	31890	BOTTOM FRAME WELDMENT
2	4	21211-0034	HEX HD. BOLT 1/2" UNC X 3"
3	8	21421-0002	LOCKWASHER
4	1	31899	TOP FRAME WELDMENT
5	4	21251-0019	HEX SOCKET HD. SCREW 1/2"-13 UNC X 1"
6	4	37115-0209	CORNER POST WELDMENT
7	4	22450-0028	3/4" STUD ADJ. 6" (152mm) LEG
8	2	35122-0049	TIE PLATE ATTACH. STRIP (Included with oven)
10	A/R	21292-0001	HEX WASHER HD. SCREW #2 PT.
11	1	35159	INSULATION COVER PLATE

WARNING

Improper installation, adjustment, alteration, service or maintenance can cause property damage, injury or death. Read the installation, operating and maintenance instructions thoroughly before installing or servicing this equipment.

NOTICE

During the warranty period, ALL parts replacement and servicing should be performed by your Middleby Marshall Authorized Service Agent. Service that is performed by parties other than your Middleby Marshall Authorized Service Agent may void your warranty.

NOTICE

Using any parts other than genuine Middleby Marshall factory manufactured parts relieves the manufacturer of all warranty and liability.

NOTICE

Middleby Marshall reserves the right to change specifications at any time.

PS360EVB

Middleby Cooking Systems Group • 1400 Toastmaster Drive • Elgin, IL 60120 • USA • (847)741-3300 • FAX (847)741-4406

24-Hour Service Hotline: 1-(800)-238-8444

www.middleby.com

